

# High Efficiency PWM Buck LED Driver Controller

## General Description

The RT8458 is a PWM controller with an integrated high side floating gate driver. It is used for step down converters by well controlling the external MOSFET and regulating a constant output current. The output duty cycle of the RT8458 can be up to 100% for wider input voltage application, such as E27 and PAR30 off-line LED lighting products.

The RT8458 also features a 48kHz fixed frequency oscillator, an internal 178mV precision reference, and a PWM comparator with latching logic. The accurate output LED current is achieved by an averaging current feedback loop and the LED current dimming can be easily controlled via the ACTL pin. The RT8458 also has multiple features to protect the controller from fault conditions, including Under Voltage Lockout (UVLO), Over Current Protection circuit (OCP) and Over Voltage Protection (OVP). Additionally, to ensure the system reliability, the RT8458 is built with the thermal protection function.

The RT8458 is housed in a TSOT-23-6 package. Thus, the components in the whole LED driver system can be made very compact.

## Ordering Information

RT8458□□

- Package Type  
J6 : TSOT-23-6
- Operating Temperature Range  
G : Green (Halogen Free with Commercial Standard)

Note :

Richtek Green products are :

- ▶ RoHS compliant and compatible with the current requirements of IPC/JEDEC J-STD-020.
- ▶ Suitable for use in SnPb or Pb-free soldering processes.

## Features

- Low Cost and Efficient Buck Converter Solution
- Universal Input Voltage Range with Off-Line Topology
- Programmable Constant LED Current
- Dimmable LED Current by ACTL
- Output LED String Open Protection
- Output LED String Short Protection
- Output LED String Over Current Protection
- Built-in Thermal Protection
- Tiny TSOT-23-6 Package
- RoHS Compliant and Halogen Free

## Applications

- E27, PAR30, Offline LED Lights

## Pin Configurations

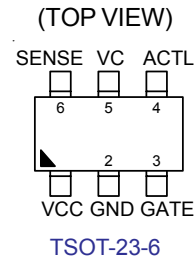

## Marking Information

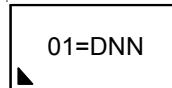

01= : Product Code  
DNN : Date Code

Typical Application Circuit

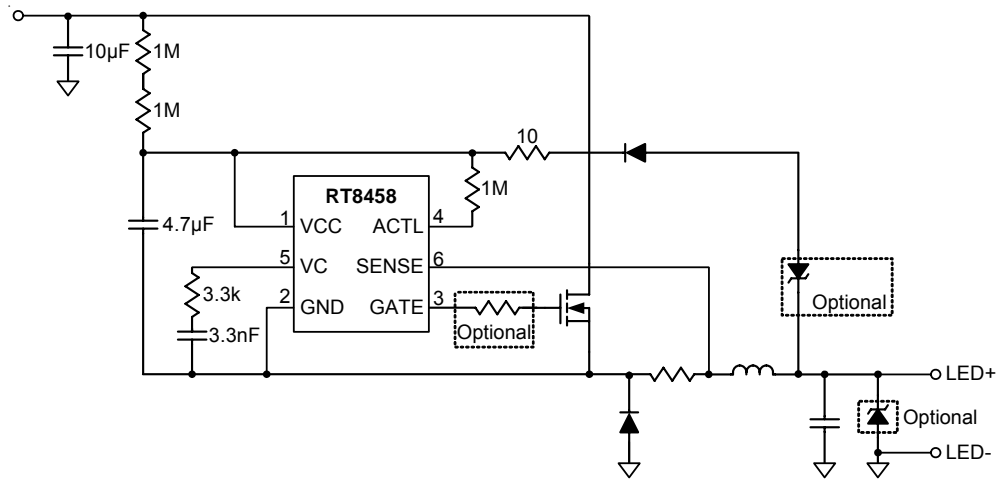

Figure 1. For Typical Application

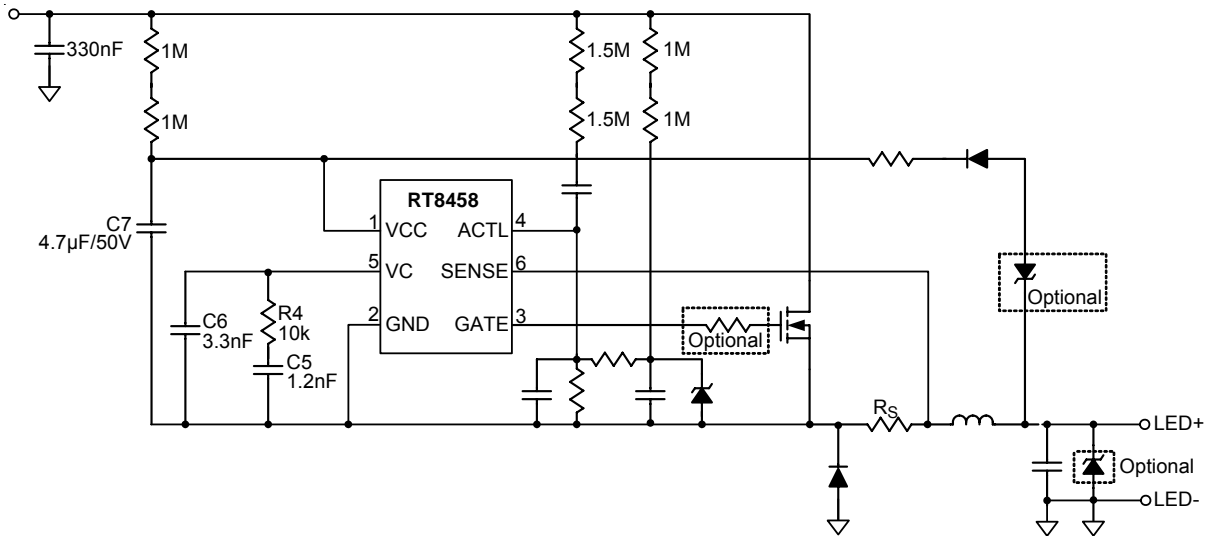
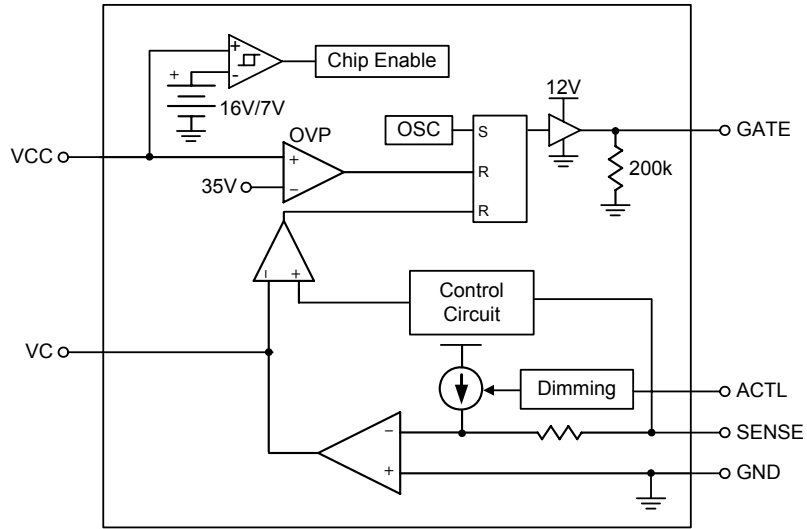

Figure 2. For High PF Application

Functional Pin Description

Pin No.	Pin Name	Pin Function
1	VCC	Power Supply Pin of the Chip. For good bypass, a ceramic capacitor near the VCC pin is required.
2	GND	Ground of the Chip.
3	GATE	Gate Driver for External MOSFET Switch.
4	ACTL	Analog Dimming Control. The typical effective dimming range is between 0.2V to 1.3V.
5	VC	PWM loop Compensation Node.
6	SENSE	LED Current Sense Input Pin. Typical sensing threshold is 178mV.

Function Block Diagram



**Absolute Maximum Ratings** (Note 1)

• Supply Input Voltage, $V_{CC}$ -----	40V
• GATE Voltage -----	14V
• ACTL Voltage -----	8V
• VC Voltage -----	6V
• SENSE Voltage -----	-0.3V to 6V
• Power Dissipation, $P_D$ @ $T_A = 25^\circ\text{C}$ TSOT-23-6 -----	0.392W
• Package Thermal Resistance (Note 2) TSOT-23-6, $\theta_{JA}$ -----	255°C/W
• Junction Temperature -----	150°C
• Lead Temperature (Soldering, 10 sec.)-----	260°C
• Storage Temperature Range -----	-65°C to 150°C
• ESD Susceptibility (Note 3) HBM (Human Body Mode) -----	2kV
MM (Machine Mode) -----	200V

**Recommended Operating Conditions** (Note 4)

• Supply Input Voltage, $V_{CC}$ -----	7V to 35V
• Junction Temperature Range -----	-40°C to 125°C

**Electrical Characteristics**

( $V_{CC} = 24V_{DC}$ ,  $C_{LOAD} = 1nF$ ,  $R_{LOAD} = 2.2\Omega$  in series,  $T_A = 25^\circ\text{C}$ , unless otherwise specified)

Parameter	Symbol	Test Conditions	Min	Typ	Max	Unit
Input Start-Up Voltage	$V_{ST}$		--	16	--	V
Maximum Startup Current	$I_{ST(MAX)}$		--	250	300	$\mu\text{A}$
Input Supply Current	$I_{CC}$	After Start-Up, $V_{CC} = 24V$	--	1.65	5	mA
Input Quiescent Current	$I_{QC}$	Before Start-Up, $V_{CC} = 15V$	--	0.1	--	$\mu\text{A}$
Over Voltage Protection	$V_{OVP}$	VCC Pin	--	35	--	V
Current Sense Voltage	$V_{SENSE}$		169	178	187	mV
Switching Frequency	$f_{SW}$		--	48	--	kHz
Oscillator Maximum Duty Cycle	$D_{MAX}$		--	--	100	%
Minimum Turn-On Time	$t_{ON(MIN)}$		300	--	--	ns
GATE Pin Maximum Voltage	$V_{GATE}$		--	12.5	--	V
GATE Voltage High	$V_{GATE\_H}$	$I_{GATE} = -20\text{mA}$	--	12.4	--	V
		$I_{GATE} = -100\mu\text{A}$	--	12.5	--	
GATE Voltage Low	$V_{GATE\_F}$	$I_{GATE} = 20\text{mA}$	--	0.75	--	V
		$I_{GATE} = 100\mu\text{A}$	--	0.5	--	
GATE Drive Rise and Fall Time		10nF Load at GATE	--	150	--	ns
GATE Drive Source and Sink Peak Current		10nF Load at GATE	--	0.8	--	A

To be continued

Parameter	Symbol	Test Conditions	Min	Typ	Max	Unit
<b>LED Dimming</b>						
Analog Dimming ACTL Pin Input Current	$I_{ACTL}$		--	1	--	$\mu A$
LED Current Off Threshold at ACTL	$V_{ACTL\_Off}$		--	--	0.1	V
VC Threshold for PWM Switch Off	$V_{VC}$		--	1.25	--	V
<b>Thermal Protection</b>						
Thermal Shutdown Temperature	$T_{SD}$		--	150	--	$^{\circ}C$

**Note 1.** Stresses listed as the above "Absolute Maximum Ratings " may cause permanent damage to the device. These are for stress ratings. Functional operation of the device at these or any other conditions beyond those indicated in the operational sections of the specifications is not implied. Exposure to absolute maximum rating conditions for extended periods may remain possibility to affect device reliability.

**Note 2.**  $\theta_{JA}$  is measured in natural convection at  $T_A = 25^{\circ}C$  on a low effective thermal conductivity test board of JEDEC 51-3 thermal measurement standard.

**Note 3.** Devices are ESD sensitive. Handling precaution is recommended.

**Note 4.** The device is not guaranteed to function outside its operating conditions.

Typical Operating Characteristics

Switching Frequency vs. Supply Voltage

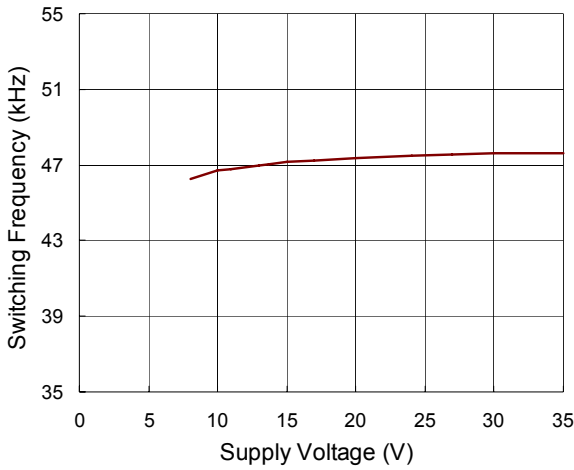

Switching Frequency vs. Temperature

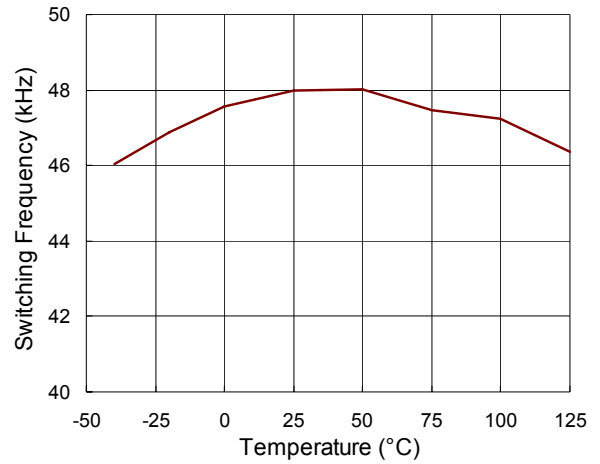

Efficiency vs. Input Voltage

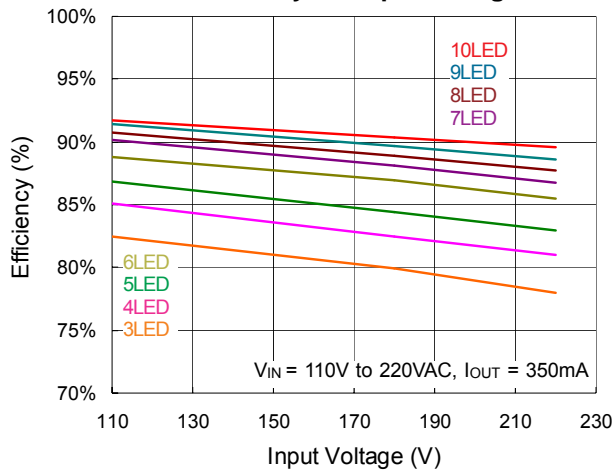

Efficiency vs. Number of LED

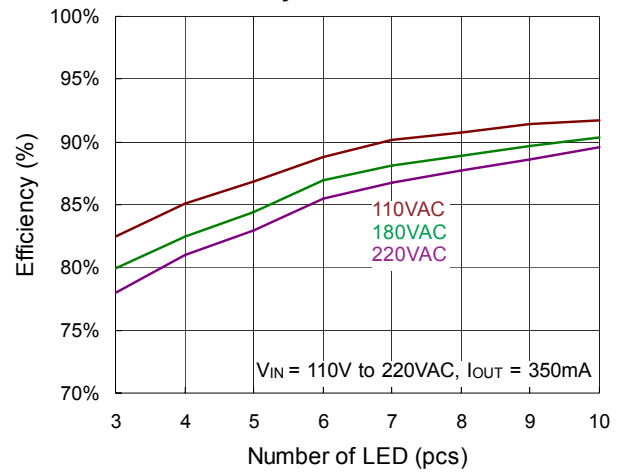

LED Current vs. V<sub>ACTL</sub>

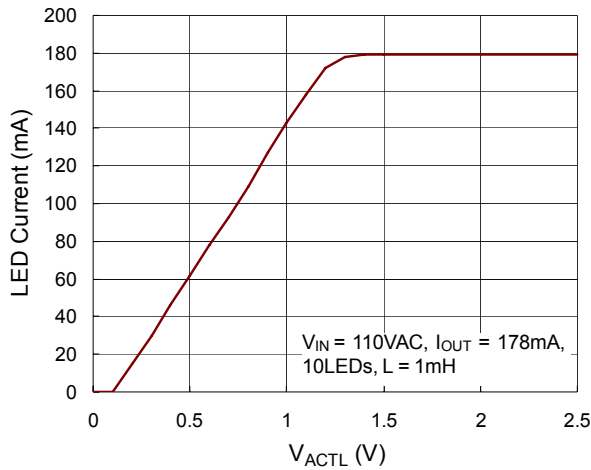

LED Current vs. Input Voltage

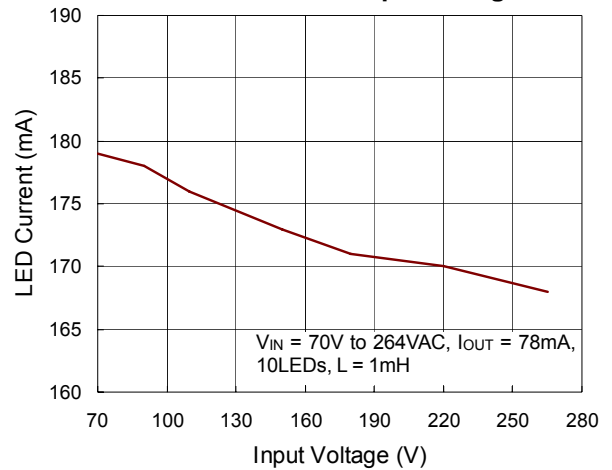

LED Current vs. Output Voltage

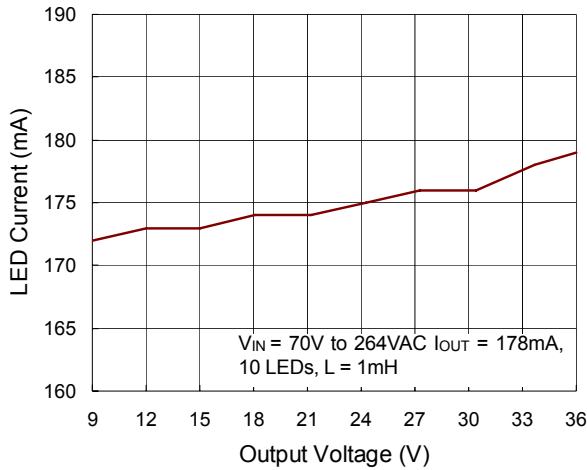

Input Voltage and Input Current

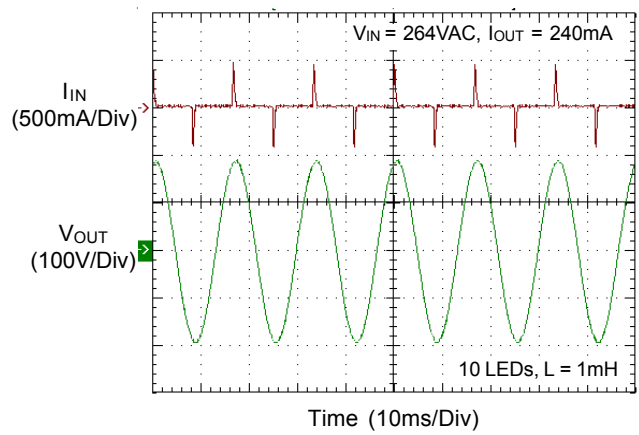

Output Current and Output Voltage

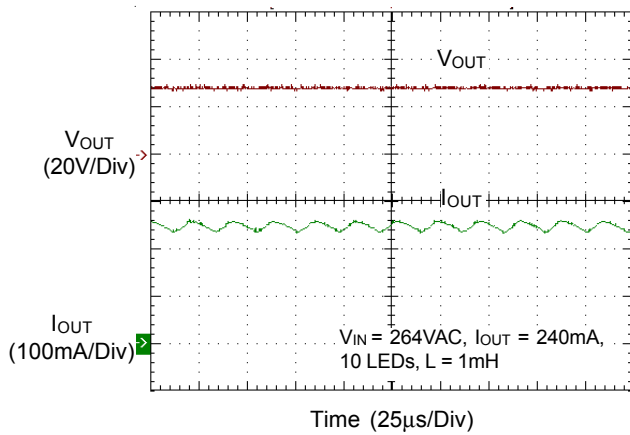

GATE Voltage and Inductor Current

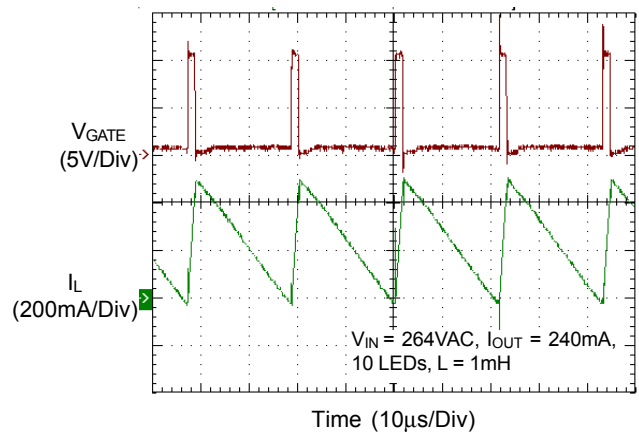

Power On

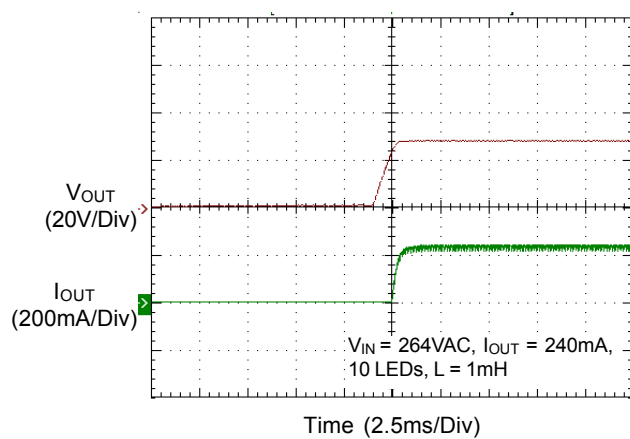

Power Off

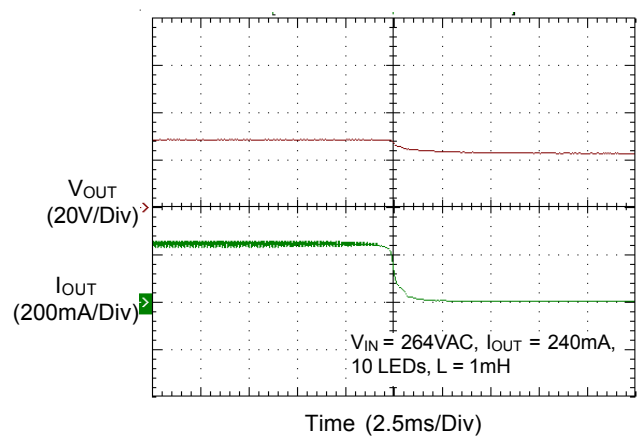

## Application Information

The RT8458 is a high efficiency PWM buck LED driver controller for high brightness LED application. Its high side floating gate driver is used to control the buck converter via an external MOSFET and regulate the constant output current.

The RT8458 can achieve high accuracy LED output current via the average current feedback loop control. The internal sense voltage (178mV typ.) is used to set the average output current. The oscillator's frequency is fixed at 48kHz to get better switching performance. Once the average current is set by the external resistor,  $R_S$ , the output LED current can be dimmed by varying the ACTL voltage.

### Under Voltage Lockout (UVLO)

The RT8458 includes a UVLO feature with 8V hysteresis. The GATE terminal turns on when  $V_{IN}$  rises over 16V (typ.). The GATE terminal turns off when  $V_{IN}$  falls below 8V (typ.)

### Setting Average Output Current

The output current that flows through the LED string is set by an external resistor,  $R_S$ , which is connected between the GND and SENSE terminal. The relationship between output current,  $I_{OUT}$ , and  $R_S$  is shown below :

$$I_{OUT} = \frac{0.178}{R_S} \quad (\text{A})$$

### Analog Dimming Control

The ACTL terminal is driven by an external voltage,  $V_{ACTL}$ , to adjust the output current to an average value set by  $R_S$ . The voltage range for  $V_{ACTL}$  to adjust the output current is from 0.2V to 1.3V. If  $V_{ACTL}$  becomes larger than 1.3V, the output current value will just be determined by the external resistor,  $R_S$ .

$$I_{OUT\text{avg}} = (0.178V/R_S) \times \frac{V_{ACTL} - 0.2}{1.1}$$

### Component Selection

For component selection, an example is shown below for a typical RT8458 application, where  $V_{IN} = 110\text{VAC}/60\text{Hz}$ , LED output voltage = 78V, and output current = 200mA. The user can follow this procedure to design applications with wider AC voltage input and DC output voltage as well.

### Start-up Resistor

Start-up resistor should be chosen not to exceed the maximum start-up current. Otherwise, the RT8458 may latch low and will never start. Start-up current =  $130V/R1$  for 110VAC regions,  $260V/R1$  for 220VAC regions. The typical start-up current is 250 $\mu\text{A}$ .

### Input Diode Bridge Rectifier Selection

The current rating of the input bridge rectifier is dependent on the  $V_{OUT}/V_{IN}$  transformation ratio. The voltage rating of the input bridge rectifier,  $V_{BR}$ , on the other hand, is only dependent on the input voltage. Thus, the  $V_{BR}$  rating is calculated as below :

$$V_{BR} = 1.2 \times (\sqrt{2} \times V_{AC(\text{MAX})})$$

where  $V_{AC,\text{Max}}$  is the maximum input voltage (RMS) and the parameter 1.2 is used for safety margin.

For this example :

$$V_{BR} = 1.2 \times (\sqrt{2} \times V_{AC(\text{MAX})}) = (1.2 \times \sqrt{2} \times 110) = 187\text{V}$$

If the input source was universal,  $V_{BR}$  will reach 466V. In this case, a 600V, 0.5A bridge rectifier can be chosen.

### Input Capacitor Selection

The input capacitor supplies the peak current to the inductor and flattens the current ripple on the input. The low ESR condition is required to avoid increasing power loss. The ceramic capacitor is recommended due to its excellent high frequency characteristic and low ESR. For maximum stability over the entire operating temperature range, capacitors with better dielectric are suggested. The minimum capacitor is given by :

$$C_{IN} \geq \frac{V_{OUT(\text{MAX})} \times I_{OUT(\text{MAX})}}{(2 \times V_{AC(\text{MIN})}^2) \times \eta \times f_{AC}}$$

where  $f_{AC}$  is the AC input source frequency and  $\eta$  is the efficiency of whole system.

For this particular example :

$$C_{IN} \geq \frac{78 \times 0.2}{(2 \times 110^2) \times 0.9 \times 60} = 12\mu\text{F}$$

In addition, the voltage rating of the input filter capacitor,  $V_{CIN}$ , should be large enough to handle the input voltage.

$$V_{CIN} \geq (1.2 \times \sqrt{2} \times V_{AC(\text{MAX})}) = (1.2 \times \sqrt{2} \times 110) = 187\text{V}$$



Thus, a 22μF / 250V electrolytic capacitor can be chosen in this case. Due to its large ESR, the electrolytic capacitor is not suggested for high current ripple applications.

**Inductor Selection**

The inductor value and operating frequency determine the ripple current according to a specific input and output voltage. The ripple current, Δ<sub>L</sub>, increases with higher V<sub>IN</sub> and decreases with higher inductance, as shown in equation below :

$$\Delta I_L = \left[ \frac{V_{OUT}}{f \times L} \right] \times \left[ 1 - \frac{V_{OUT}}{V_{IN}} \right]$$

To optimize the ripple current, the RT8458 operates the buck converter in BCM (Boundary-Condition Mode). The largest ripple current will occur at the highest V<sub>IN</sub>. To guarantee that the ripple current stays below the specified value, the inductor value should be chosen according to the following equation :

$$L = \frac{V_{OUT} \times T_S \times (1-D)}{2 \times I_{OUT}} = \frac{78 \times 20.83\mu s \times (1-0.5)}{2 \times 0.2} = 2.03mH$$

where D is the duty cycle and T<sub>S</sub> is the switching period.

**Forward Diode Selection**

When the power switch turns off, the path for the current is through the diode connected between the switch output and ground. This forward biased diode must have minimum voltage drop and recovery time. The reverse voltage rating of the diode should be greater than the maximum input voltage and the current rating should be greater than the maximum load current.

In reality, the peak current through the diode is more than the maximum output current. This component current rating should be greater than 1.2 times the maximum load current and the diode reverse voltage rating should be greater than 1.2 times the maximum input voltage, assuming a ± 20% output current ripple.

The peak voltage stress of diode is :

$$V_D = 1.2 \times (\sqrt{2} \times V_{AC(MAX)}) = 1.2 \times (\sqrt{2} \times 110) = 187V$$

The current rating of diode is :

$$I_D = 1.2 \times I_{OUT,PK} = 1.2 \times 1.2 \times 0.2 = 0.288A$$

If the input source is universal (V<sub>IN</sub> = 90V to 264V), V<sub>D</sub> will reach 466V. A 600V, 2A ultra-fast diode can be used in this example.

**MOSFET Selection**

The peak current through this MOSFET will be over the maximum output current. This component current rating should be greater than 1.2 times the maximum load current and the reverse voltage rating of the MOSFET should be greater than 1.2 times the maximum input voltage, assuming a ± 20% output current ripple.

The peak voltage rating of the MOSFET is :

$$V_Q = 1.2 \times (\sqrt{2} \times V_{AC(MAX)}) = 1.2 \times (\sqrt{2} \times 110) = 187V$$

The current rating of MOSFET is :

$$I_Q = 1.2 \times I_{OUT,PK} = 1.2 \times 1.2 \times 0.2 = 0.288A$$

If the input source was universal (V<sub>IN</sub> = 90V to 264V), V<sub>Q</sub> will reach 466V. A 600V, 2A N-MOSFET can be chosen for this example.

**Output Capacitor Selection**

The selection of C<sub>OUT</sub> is determined by the required ESR to minimize output voltage ripple. Moreover, the amount of bulk capacitance is also a key for C<sub>OUT</sub> selection to ensure that the control loop is stable. Loop stability can be checked by viewing the load transient response. The output voltage ripple, ΔV<sub>OUT</sub>, is determined by :

$$\Delta V_{OUT} \leq \Delta I_L \left[ ESR + \frac{1}{8f_{OSC}C_{OUT}} \right]$$

where f<sub>OSC</sub> is the switching frequency and Δ<sub>L</sub> is the inductor ripple current. The output voltage ripple will be the highest at the maximum input voltage since Δ<sub>L</sub> increases with input voltage. Multiple capacitors placed in parallel may be needed to meet the ESR and RMS current handling requirement. Dry tantalum, special polymer, aluminum electrolytic and ceramic capacitors are all common selections and available in surface mount packages. Tantalum capacitors have the highest capacitance density, but it is important to only use ones that pass the surge test for use in switching power

supplies. Special polymer capacitors offer very low ESR value, but with the trade-off of lower capacitance density. Aluminum electrolytic capacitors have significantly higher ESR, but still can be used in cost-sensitive applications for ripple current rating and long term reliability considerations.

**Thermal Protection**

A thermal protection feature is included to protect the RT8458 from excessive heat damage. When the junction temperature exceeds a threshold of 150°C, the thermal protection will turn off the GATE terminal.

**Thermal Considerations**

For continuous operation, do not exceed absolute maximum junction temperature. The maximum power dissipation depends on the thermal resistance of the IC package, PCB layout, rate of surrounding airflow, and difference between junction and ambient temperature. The maximum power dissipation can be calculated by the following formula :

$$P_{D(MAX)} = (T_{J(MAX)} - T_A) / \theta_{JA}$$

where  $T_{J(MAX)}$  is the maximum junction temperature,  $T_A$  is the ambient temperature, and  $\theta_{JA}$  is the junction to ambient thermal resistance.

For recommended operating condition specifications of the RT8458, the maximum junction temperature is 125°C and  $T_A$  is the ambient temperature. The junction to ambient thermal resistance,  $\theta_{JA}$ , is layout dependent. For TSOT-23-6 packages, the thermal resistance,  $\theta_{JA}$ , is 255°C/W on a standard JEDEC 51-3 single-layer thermal test board. The maximum power dissipation at  $T_A = 25^\circ\text{C}$  can be calculated by the following formula :

$$P_{D(MAX)} = (125^\circ\text{C} - 25^\circ\text{C}) / (255^\circ\text{C/W}) = 0.392\text{W for TSOT-23-6 package}$$

The maximum power dissipation depends on the operating ambient temperature for fixed  $T_{J(MAX)}$  and thermal resistance,  $\theta_{JA}$ . For the RT8458 package, the derating curve in Figure 3 allows the designer to see the effect of rising ambient temperature on the maximum power dissipation.

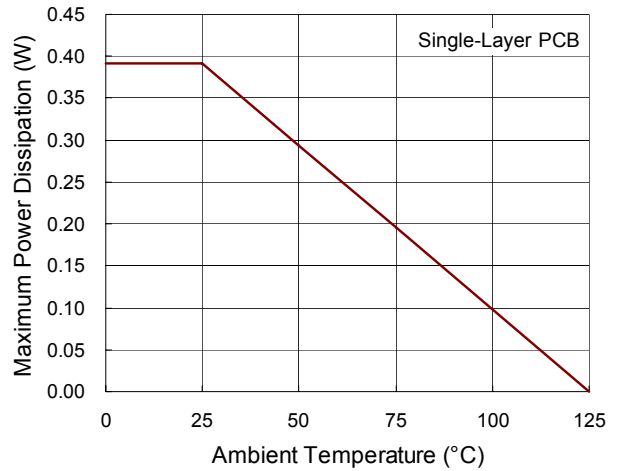
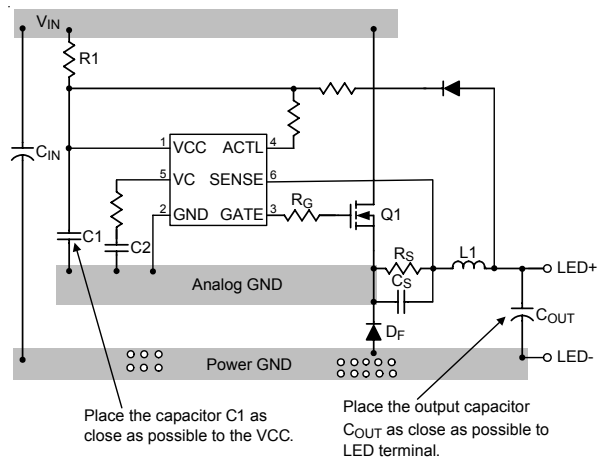

Figure 3. Derating Curve for RT8458 Package

**Layout Considerations**

For best performance of the RT8458, the following layout guidelines should be strictly followed.

- ▶ The hold up capacitor, C<sub>1</sub>, must be placed as close as possible to the VCC pin.
- ▶ The output capacitor, C<sub>OUT</sub>, must be placed as close as possible to the LED terminal.
- ▶ The power GND should be connected to a strong ground plane.
- ▶ R<sub>S</sub> should be connected between the GND pin and SENSE pin.
- ▶ Keep the main current traces as short and wide as possible.
- ▶ Place L1, Q1, R<sub>S</sub>, and D<sub>F</sub> as close to each other as possible.



Place the capacitor C1 as close as possible to the VCC. Place the output capacitor COUT as close as possible to LED terminal.

Figure 4. PCB Layout Guide

**Outline Dimension**

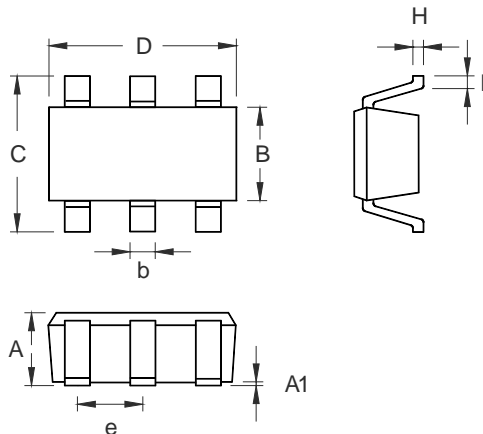

Symbol	Dimensions In Millimeters		Dimensions In Inches	
	Min	Max	Min	Max
A	0.700	1.000	0.028	0.039
A1	0.000	0.100	0.000	0.004
B	1.397	1.803	0.055	0.071
b	0.300	0.559	0.012	0.022
C	2.591	3.000	0.102	0.118
D	2.692	3.099	0.106	0.122
e	0.838	1.041	0.033	0.041
H	0.080	0.254	0.003	0.010
L	0.300	0.610	0.012	0.024

**TSOT-23-6 Surface Mount Package**

**Richtek Technology Corporation**

Headquarter  
 5F, No. 20, Taiyuen Street, Chupei City  
 Hsinchu, Taiwan, R.O.C.  
 Tel: (8863)5526789 Fax: (8863)5526611

**Richtek Technology Corporation**

Taipei Office (Marketing)  
 5F, No. 95, Minchiuan Road, Hsintien City  
 Taipei County, Taiwan, R.O.C.  
 Tel: (8862)86672399 Fax: (8862)86672377  
 Email: marketing@richtek.com

Information that is provided by Richtek Technology Corporation is believed to be accurate and reliable. Richtek reserves the right to make any change in circuit design, specification or other related things if necessary without notice at any time. No third party intellectual property infringement of the applications should be guaranteed by users when integrating Richtek products into any application. No legal responsibility for any said applications is assumed by Richtek.

**Datasheet Revision History**

Version	Date	Page No.	Item	Description
P00	2010/7/29			First Edition
P01	2010/9/1		General Description Features Typical Application Circuit Functional Pin Description Function Block Diagram Absolute Maximum Ratings Recommended Operating Conditions Electrical Characteristics	Modify
P02	2010/11/29		General Description Typical Application Circuit Electrical Characteristics	Modify Add Typical Operating Characteristics and Application Information
P03	2011/2/14		General Description Ordering Information Features Marking Information Function Pin Description Absolute Maximum Ratings Electrical Characteristics Application Information Outline Dimension	Modify Changer SOT-23-6 to TSOT-23-6