



50mA SWITCHED-CAP DC/DC CONVERTER

FEATURES

- WIDE INPUT RANGE: 1.8V TO 5.5V
5V VERSION: 2.7V TO 5.5V
- AUTOMATIC STEP-UP/STEP-DOWN OPERATION
- LOW INPUT CURRENT RIPPLE
- LOW OUTPUT VOLTAGE RIPPLE
- MINIMUM NUMBER OF EXTERNAL COMPONENTS—NO INDUCTORS
- 1MHz INTERNAL OSCILLATOR ALLOWS SMALL CAPACITORS
- “SHUTDOWN” MODE
- THERMAL AND CURRENT LIMIT PROTECTION
- FIVE OUTPUT VOLTAGES AVAILABLE: 5.0V, 3.3V, 3.0V, 2.7V, 2.5V
- THIN, SMALL PACKAGE: MSOP-8

APPLICATIONS

- SMART CARD READERS
- CELLULAR PHONES
- SIM CARD SUPPLIES
- PORTABLE COMMUNICATION DEVICES
- PERSONAL DIGITAL ASSISTANTS
- MODEMS
- NOTEBOOK AND PALM-TOP COMPUTERS
- ELECTRONIC GAMES
- HANDHELD METERS
- PCMCIA CARDS
- CARD BUSES
- LCD DISPLAYS

DESCRIPTION

The REG711 is a switched capacitor voltage converter, which produces a regulated, low ripple output voltage from an unregulated input voltage. A wide input supply voltage of 1.8V to 5.5V makes the REG711 ideal for a variety of battery sources, such as single cell Li-Ion, or two and three cell Nickel or Alkaline based chemistries.

The input voltage may vary above and below the output voltage and the output will remain in regulation. It works equally well for step up or down without the need for an inductor, providing low EMI DC/DC conversion. The high switching frequency allows the use of small surface-mount capacitors, saving board space and reducing cost. The REG711 is thermally protected and current limited, protecting the load and the regulator during fault conditions. Typical ground pin current (quiescent current) is 1mA at full load, 60 μ A with no load, and less than 1 μ A in shutdown mode. This regulator comes in a thin MSOP-8 package with a component height of less than 1.1mm.

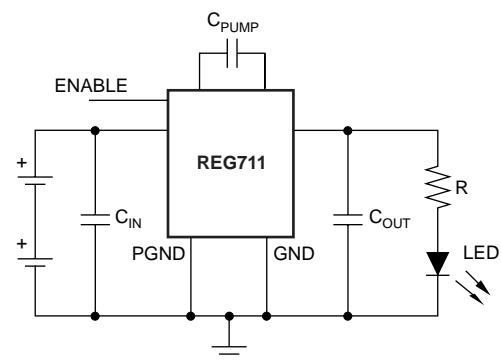

SPECIFICATIONS

Boldface limits apply over the specified temperature range, $T_A = -40^{\circ}\text{C}$ to $+85^{\circ}\text{C}$

At $T_A = +25^{\circ}\text{C}$, $V_{IN} = V_{OUT}/2 + 0.75\text{V}$, $I_{OUT} = 5\text{mA}$, $C_{IN} = C_{OUT} = 2.2\mu\text{F}$, $C_{PUMP} = 0.22\mu\text{F}$, $V_{ENABLE} = 1.3\text{V}$, unless otherwise noted⁽¹⁾.

| PARAMETER | CONDITIONS | REG711EA | | | UNITS |
|---|--|-------------|------|----------------------------|-----------------------------|
| | | MIN | TYP | MAX | |
| INPUT VOLTAGE Guaranteed Startup REG711-5.0 All Other Models | See conditions under "output voltage" with a resistive load not lower than typical V_{OUT}/I_{OUT} . | 2.7 | | 5.5 | V |
| | | 1.8 | | 5.5 | V |
| OUTPUT VOLTAGE REG711-5.0 | $I_{OUT} \leq 15\text{mA}$, $2.7\text{V} < V_{IN} < 5.5\text{V}$ | 4.75 | 5.0 | 5.25 | V |
| | $I_{OUT} \leq 50\text{mA}$, $3.0\text{V} < V_{IN} < 5.5\text{V}$ | | | | |
| REG711-3.3 | $I_{OUT} \leq 15\text{mA}$, $1.8\text{V} < V_{IN} < 5.5\text{V}$ | 3.14 | 3.3 | 3.46 | V |
| | $I_{OUT} \leq 50\text{mA}$, $2.2\text{V} < V_{IN} < 5.5\text{V}$ | | | | |
| REG711-3.0 | $I_{OUT} \leq 15\text{mA}$, $1.8\text{V} < V_{IN} < 5.5\text{V}$ | 2.85 | 3.0 | 3.15 | V |
| | $I_{OUT} \leq 50\text{mA}$, $2.2\text{V} < V_{IN} < 5.5\text{V}$ | | | | |
| REG711-2.7 | $I_{OUT} \leq 15\text{mA}$, $1.8\text{V} < V_{IN} < 5.5\text{V}$ | 2.57 | 2.7 | 2.83 | V |
| | $I_{OUT} \leq 50\text{mA}$, $2.0\text{V} < V_{IN} < 5.5\text{V}$ | | | | |
| REG711-2.5 | $I_{OUT} \leq 15\text{mA}$, $1.8\text{V} < V_{IN} < 5.5\text{V}$ | 2.38 | 2.5 | 2.62 | V |
| | $I_{OUT} \leq 50\text{mA}$, $2.0\text{V} < V_{IN} < 5.5\text{V}$ | | | | |
| OUTPUT CURRENT Nominal Short Circuit ⁽²⁾ | | 50 | | | mA mA |
| | | | 80 | | |
| OSCILLATOR FREQUENCY | NOTE ⁽³⁾ | | 1.0 | | MHz |
| EFFICIENCY⁽⁴⁾ | $I_{OUT} = 15\text{mA}$, $V_{IN} = 2.7\text{V}$, REG711-5.0 | | 90 | | % |
| RIPPLE VOLTAGE⁽¹⁾ | $I_{OUT} = 50\text{mA}$ | | 40 | | mVp-p |
| ENABLE CONTROL Logic High Input Voltage Logic Low Input Voltage Logic High Input Current Logic Low Input Current | $V_{IN} = 1.8$ to 5.5V | 1.3 | | V_{IN} | V |
| | | -0.2 | | 0.4 | V |
| | | | | 100 | nA |
| | | | | 100 | nA |
| THERMAL SHUTDOWN Shutdown temperature Shutdown recovery | | | 160 | | $^{\circ}\text{C}$ |
| | | | 140 | | $^{\circ}\text{C}$ |
| SUPPLY CURRENT (quiescent current) In Shutdown Mode | $I_{OUT} = 0\text{mA}$ $V_{IN} = 1.8$ to 5.5V , Enable = 0V | | 60 | 100 | μA |
| | | | 0.01 | 2 | μA |
| TEMPERATURE RANGE Specification Operating Storage Thermal Resistance, θ_{JA} | MSOP-8 | | -40 | +85 | $^{\circ}\text{C}$ |
| | | | -55 | +125 | $^{\circ}\text{C}$ |
| | | | -65 | +150 | $^{\circ}\text{C}$ |
| | | | | 150 | $^{\circ}\text{C}/\text{W}$ |

NOTES: (1) Effective series resistance (ESR) of capacitors is $< 0.1\Omega$. (2) The supply circuit is twice the output short-circuit current. (3) The converter regulates by enabling and disabling periods of switching cycles. The switching frequency is the oscillator frequency during an active period. (4) See efficiency curves for other V_{IN}/V_{OUT} configurations.

PIN CONFIGURATION

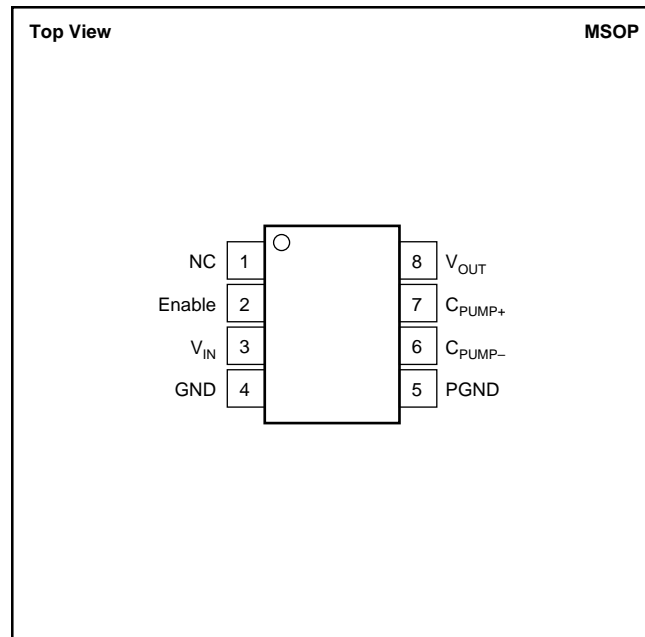

SIMPLIFIED BLOCK DIAGRAM

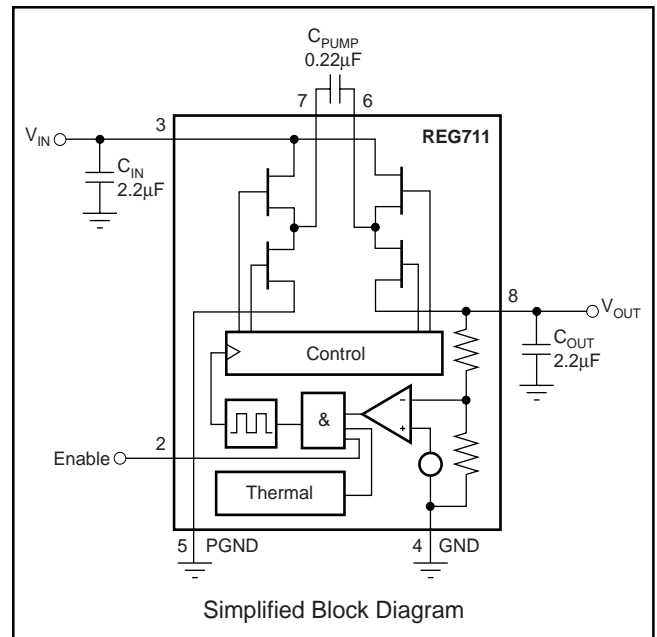

ABSOLUTE MAXIMUM RATINGS⁽¹⁾

| | |
|----------------------------------|-------------------|
| Supply Voltage | -0.3V to +5.5V |
| Enable Input | -0.3V to V_{IN} |
| Output Short-Circuit Duration | Indefinite |
| Operating Temperature Range | -55°C to +125°C |
| Storage Temperature Range | -65°C to +150°C |
| Junction Temperature | -55°C to +150°C |
| Lead Temperature (soldering, 3s) | +240°C |

NOTE: (1) Stresses above these ratings may cause permanent damage. Exposure to absolute maximum conditions for extended periods may degrade device reliability.



ELECTROSTATIC DISCHARGE SENSITIVITY

This integrated circuit can be damaged by ESD. Texas Instruments recommends that all integrated circuits be handled with appropriate precautions. Failure to observe proper handling and installation procedures can cause damage.

ESD damage can range from subtle performance degradation to complete device failure. Precision integrated circuits may be more susceptible to damage because very small parametric changes could cause the device not to meet its published specifications.

PACKAGE/ORDERING INFORMATION

| PRODUCT | OUTPUT VOLTAGE | PACKAGE | PACKAGE DRAWING NUMBER | SPECIFIED TEMPERATURE RANGE | PACKAGE MARKING ⁽¹⁾ | ORDERING NUMBER ⁽²⁾ | TRANSPORT MEDIA |
|------------------------------------|----------------|---------|------------------------|-----------------------------|--------------------------------|--|---|
| 5V Output REG711EA-5 | 5.0V | MSOP-8 | 337 | -40°C to +85°C | C11B | REG711EA-5 REG711EA-5/250 REG711EA-5/2K5 | Rails Tape and Reel Tape and Reel |
| 3.3V Output REG711EA-3.3 | 3.3V | MSOP-8 | 337 | -40°C to +85°C | C11C | REG711EA-3.3 REG711EA-3.3/250 REG711EA-3.3/2K5 | Rails Tape and Reel Tape and Reel |
| 3V Output REG711EA-3.0 | 3.0V | MSOP-8 | 337 | -40°C to +85°C | C11D | REG711EA-3 REG711EA-3/250 REG711EA-3/2K5 | Rails Tape and Reel Tape and Reel |
| 2.7V Output REG711EA-2.7 | 2.7V | MSOP-8 | 337 | -40°C to +85°C | C11F | REG711EA-2.7 REG711EA-2.7/250 REG711EA-2.7/2K5 | Rails Tape and Reel Tape and Reel |
| 2.5V Output REG711EA-2.5 | 2.5V | MSOP-8 | 337 | -40°C to +85°C | C11G | REG711EA-2.5 REG711EA-2.5/250 | Rails Tape and Reel |

NOTE: (1) Voltage will be marked on reel. (2) Models with a slash (/) are available only in Tape and Reel in the quantities indicated (e.g., /2K5 indicates 2500 devices per reel). Ordering 2500 pieces of "REG711EA-5/2K5" will get a single 2500-piece Tape and Reel.

TYPICAL PERFORMANCE CURVES

At $T_A = +25^\circ\text{C}$, $V_{IN} = V_{OUT}/2 + 0.75\text{V}$, $I_{OUT} = 5\text{mA}$, $C_{IN} = C_{OUT} = 2.2\mu\text{F}$, $C_{PUMP} = 0.22\mu\text{F}$, unless otherwise noted.

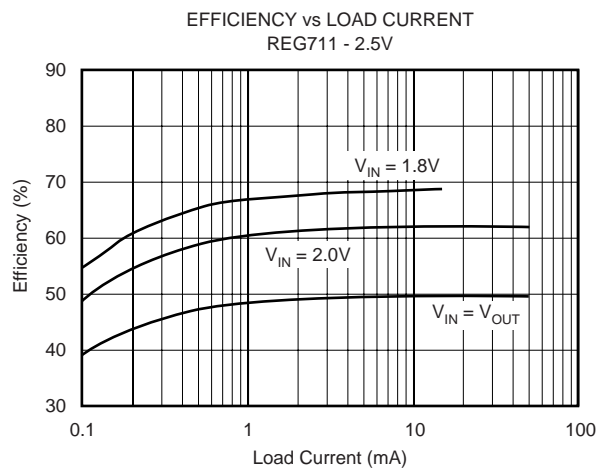
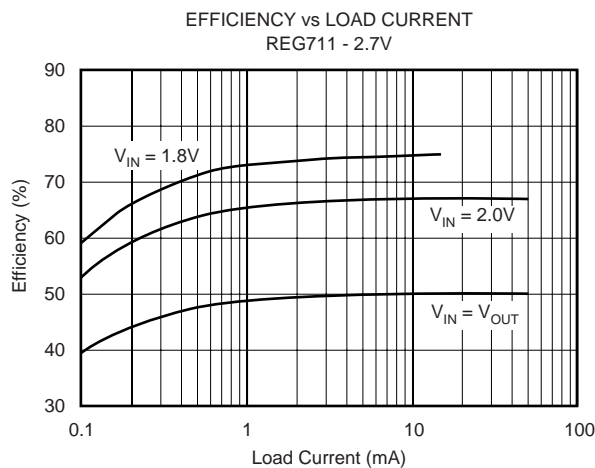
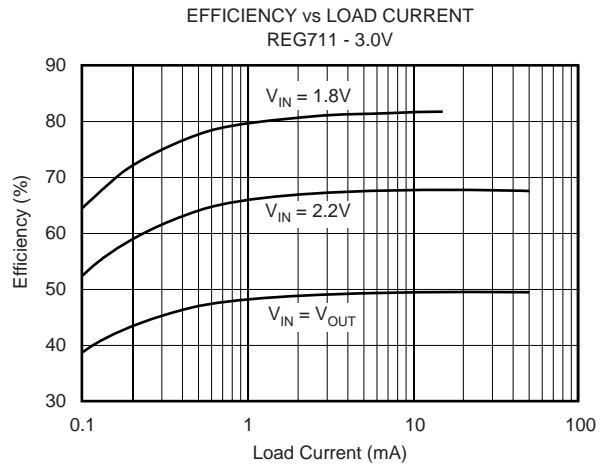
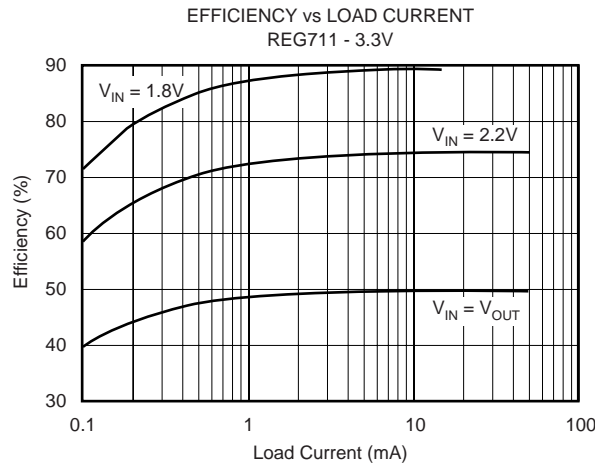
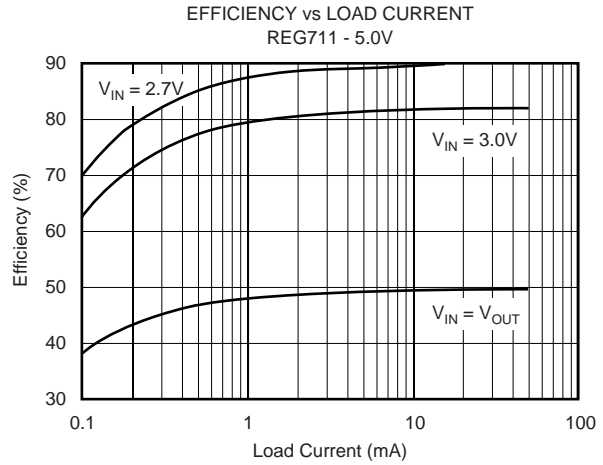
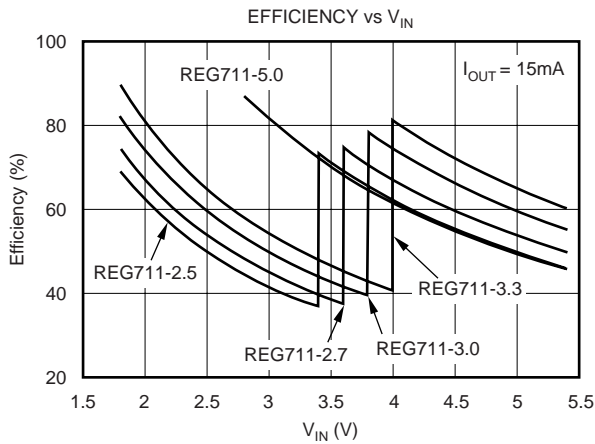

TYPICAL PERFORMANCE CURVES (Cont.)

At $T_A = +25^\circ\text{C}$, $V_{IN} = V_{OUT}/2 + 0.75\text{V}$, $I_{OUT} = 5\text{mA}$, $C_{IN} = C_{OUT} = 2.2\mu\text{F}$, $C_{PUMP} = 0.22\mu\text{F}$, unless otherwise noted.

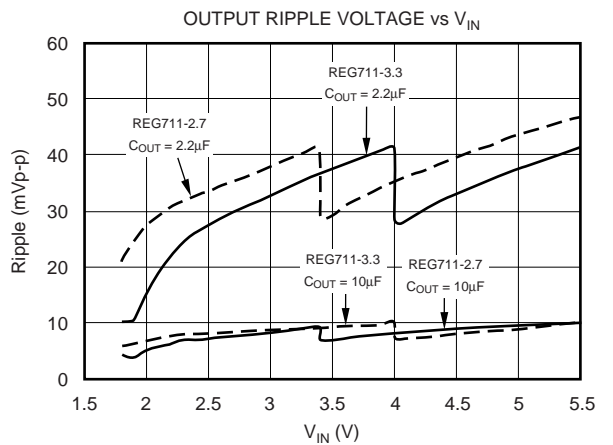
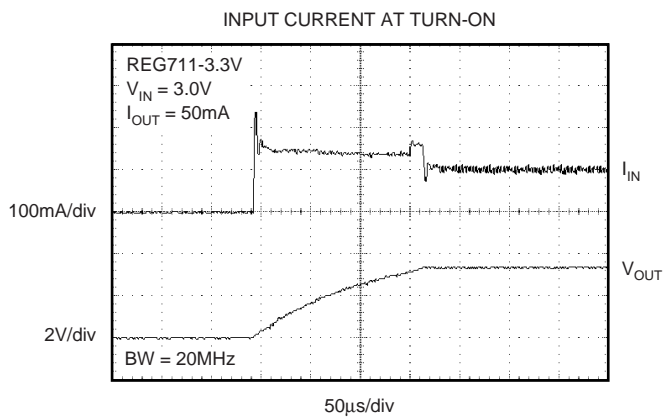
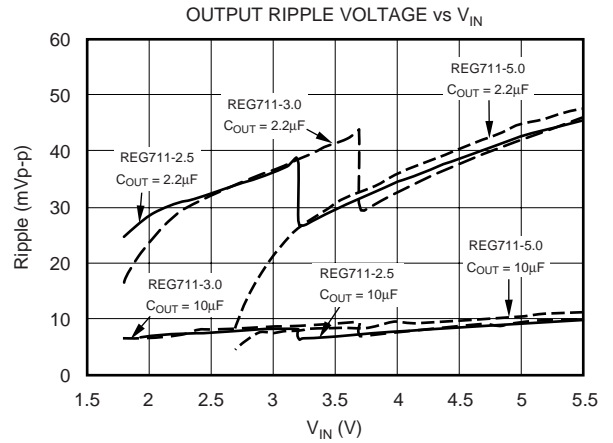
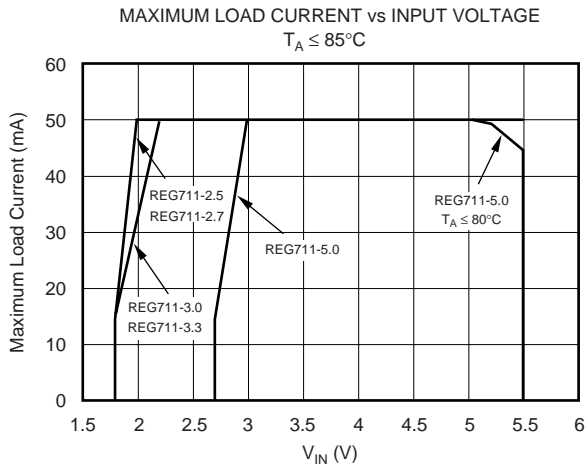
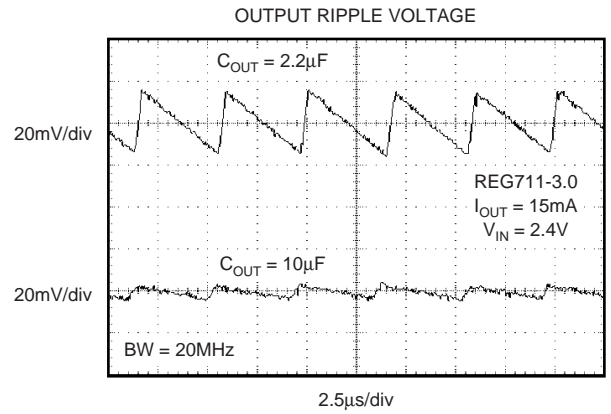
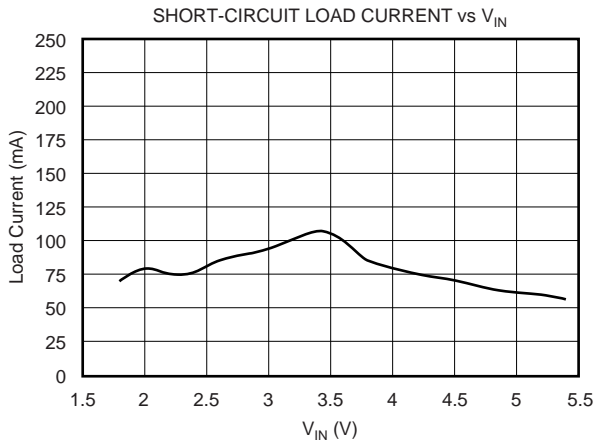

TYPICAL PERFORMANCE CURVES (Cont.)

At $T_A = +25^\circ\text{C}$, $V_{IN} = V_{OUT}/2 + 0.75\text{V}$, $I_{OUT} = 5\text{mA}$, $C_{IN} = C_{OUT} = 2.2\mu\text{F}$, $C_{PUMP} = 0.22\mu\text{F}$, unless otherwise noted.

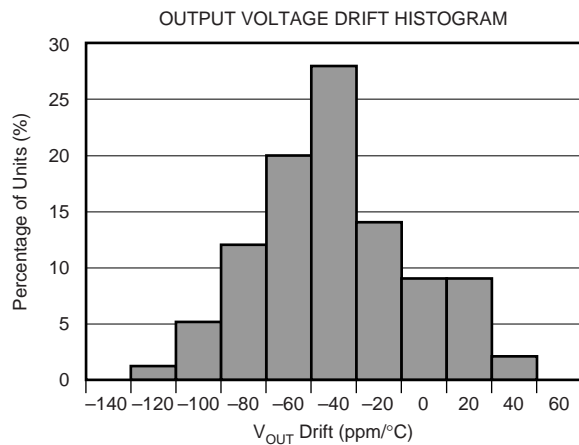
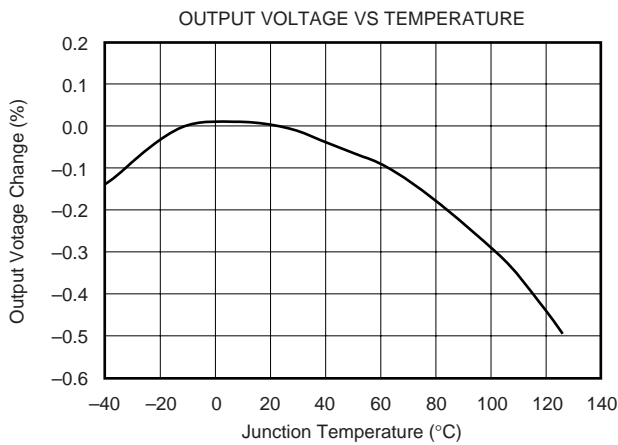
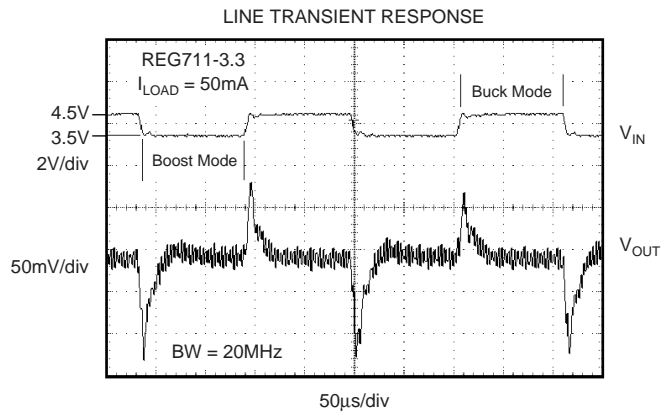
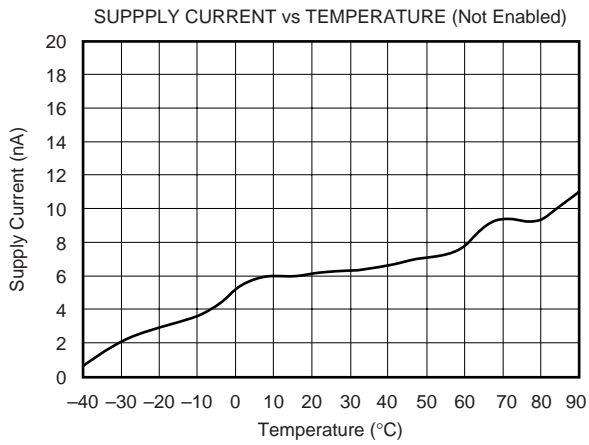
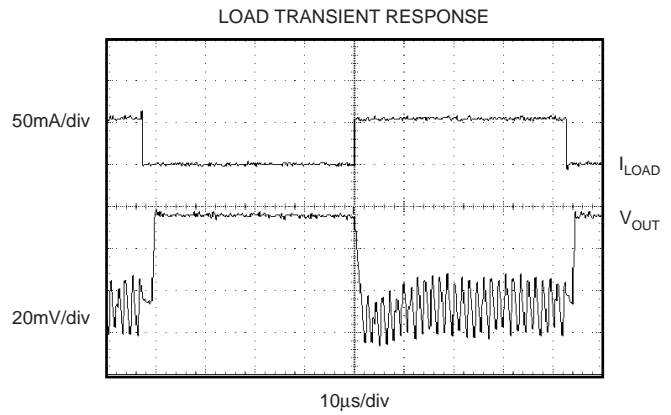
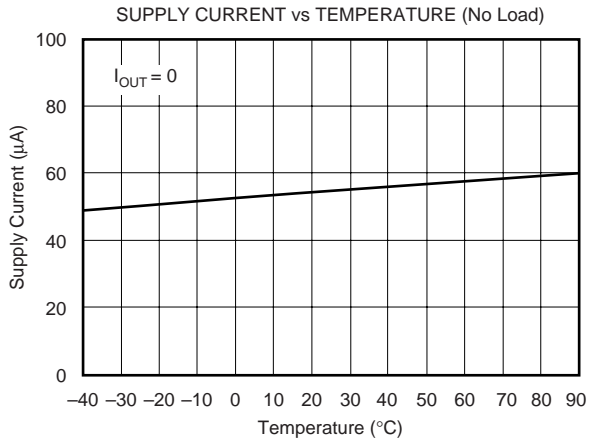

THEORY OF OPERATION

The REG711 regulated charge pump provides a regulated output voltage for input voltages ranging from less than the output to greater than the output. This is accomplished by automatic mode switching within the device. When the input voltage is greater than the required output, the unit functions as a variable pulse-width switch-mode regulator. This operation is shown in Figure 1. Transistors Q_1 and Q_3 are held off, Q_4 is on, and Q_2 is switched as needed to maintain a regulated output voltage.

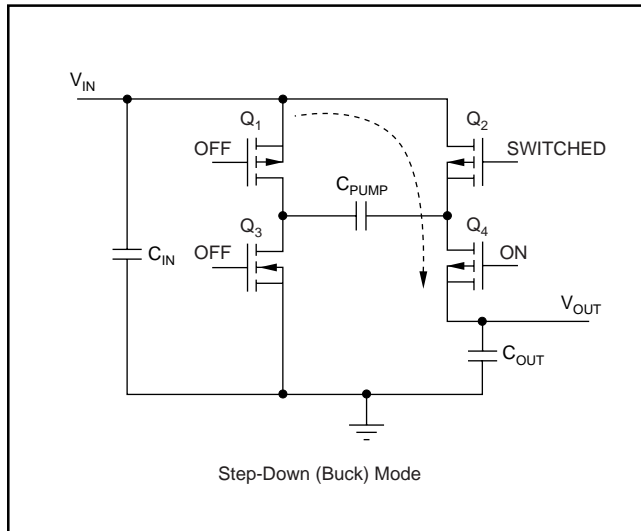

FIGURE 1. Simplified Schematic of the REG711 Operating in the Step-Down Mode.

When the input voltage is less than the required output voltage, the device switched to a step-up or boost mode of operation, as shown in Figure 2.

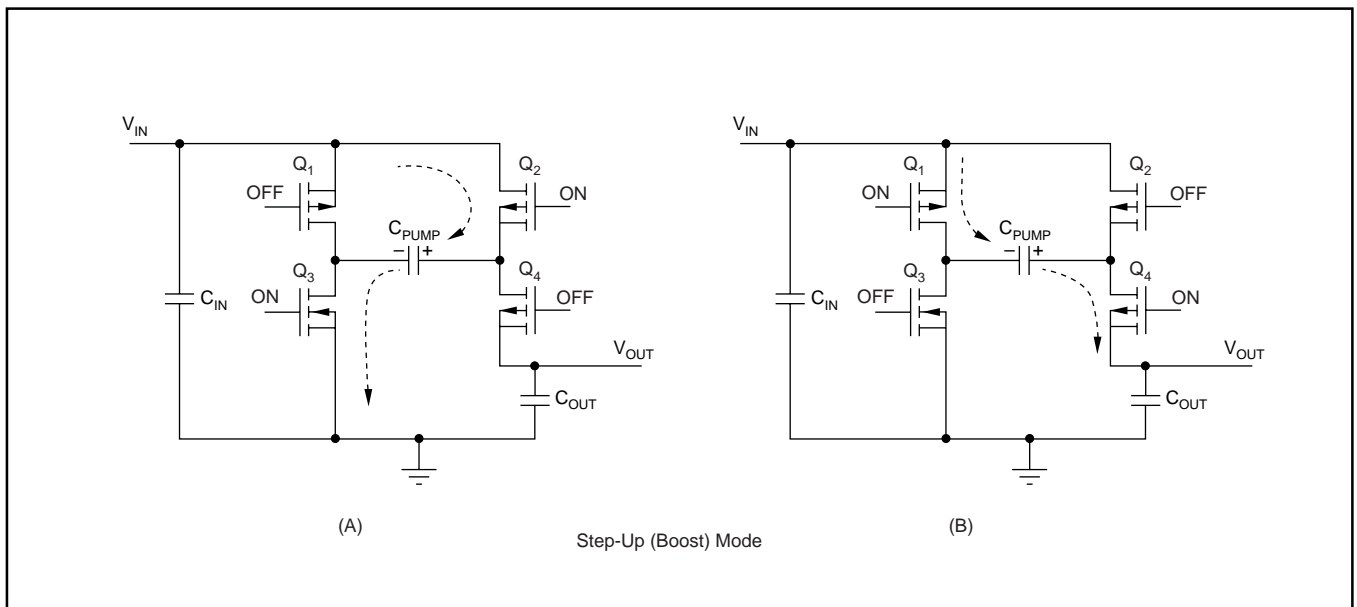

FIGURE 2. Simplified Schematic of the REG711 Operating in the Step-Up or Boost Mode.

A conversion clock of 50% duty cycle is generated. During the first half cycle the FET switches are configured as shown in Figure 2A, and C_{PUMP} charges to V_{IN} . During the second half cycle the FET switches are configured as shown in Figure 2B, and the voltage on C_{PUMP} is added to V_{IN} . The output voltage is regulated by skipping clock cycles as necessary.

PEAK CURRENT REDUCTION

In normal operation, the charging of the pump and output capacitors usually leads to relatively high peak input currents which can be much higher than that of the average load current. The regulator incorporates circuitry to limit the input peak current, lowering the total EMI production of the device and lowering output voltage ripple and input current ripple. Input capacitor (C_{IN}) supplies most of the charge required by input current peaks.

PROTECTION

The regulator has thermal shutdown circuitry that protects it from damage caused by overload conditions. The thermal protection circuitry disables the output when the junction temperature reaches approximately 160°C , allowing the device to cool. When the junction temperature cools to approximately 140°C , the output circuitry is automatically re-enabled. Continuously running the regulator into thermal shutdown can degrade reliability. The regulator also provides current limit to protect itself and the load.

SHUTDOWN MODE

A control pin on the regulator can be used to place the device into an energy-saving shutdown mode. In this mode, the output is disconnected from the input as long as V_{IN} is greater than or equal to minimum V_{IN} and the input quiescent current is reduced to $2\mu\text{A}$ maximum.

CAPACITOR SELECTION

For minimum output voltage ripple, the output capacitor C_{OUT} should be a ceramic, surface-mount type. Tantalum capacitors generally have a higher Effective Series Resistance (ESR) and may contribute to higher output voltage ripple. Leaded capacitors also increase ripple due to the higher inductance of the package itself. To achieve best operation with low input voltage and high load current, the input and pump capacitors (C_{IN} , C_{PUMP} respectively) should also be surface-mount ceramic types. In all cases, X7R or X5R dielectric are recommended. See the Typical Operating Circuit shown in Figure 3 for component values.

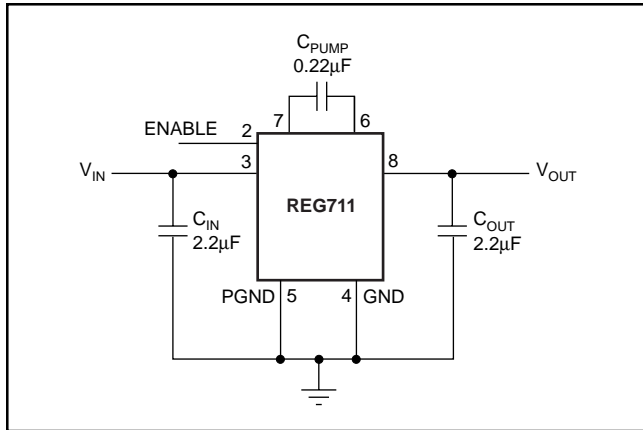

FIGURE 3. Typical Operating Circuit.

With light loads or higher input voltage, a smaller $0.1\mu\text{F}$ pump capacitor (C_{PUMP}) and smaller $1\mu\text{F}$ input and output capacitors (C_{IN} and C_{OUT} , respectively) can be used. To minimize output voltage ripple, increase the output capacitor, C_{OUT} , to $10\mu\text{F}$ or larger.

The capacitors listed in Table I have been used with the REG711. This is only a representative list of those parts that are compatible, and not the results of a complete survey of an industry-wide offering.

EFFICIENCY

The efficiency of the charge pump regulator varies with the output voltage version, the applied input voltage, the load current, and the internal operation mode of the device.

The approximate efficiency is given by:

$$\text{Efficiency (\%)} = \frac{V_{OUT}}{2 \cdot V_{IN}} \cdot 100 \text{ (step-up operating mode)}$$

or

$$V_{OUT} \cdot 100 / V_{IN} \text{ (step-down operating mode)}$$

Table II lists the approximate values of the input voltage at which the device changes internal operating mode.

| PRODUCT | OPERATING MODE CHANGES AT V_{IN} OF |
|------------|---------------------------------------|
| REG711-2.5 | > 3.2V |
| REG711-2.7 | > 3.4V |
| REG711-3.0 | > 3.7V |
| REG711-3.3 | > 4.0V |
| REG711-5.0 | Step-up only |

TABLE II.

See efficiency curves in the Typical Performance Curves section for various loads and input voltages.

LAYOUT

Large ripple currents flow in the V_{IN} , PGND and V_{OUT} traces. To minimize both input and output ripple, keep the capacitors as close as possible to the regulator using short, direct circuit traces.

A suggested PCB routing is shown in Figure 4. The trace lengths from the input and output capacitors have been kept as short as possible. A star ground system has been implemented, with pin 5 as the center of the star. No ground plane is provided in other layers, as this will provide capacitive coupling for noise spikes.

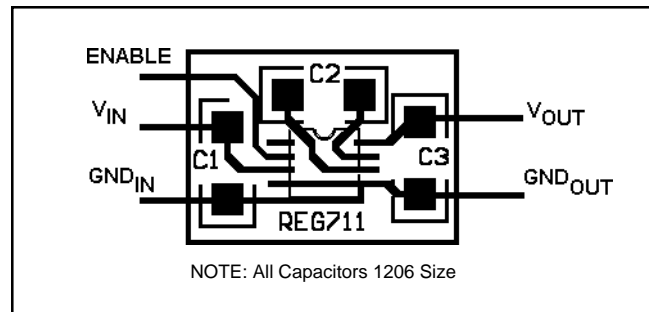

FIGURE 4. Suggested PCB Design for Minimum Ripple.

| MANUFACTURER | PART NUMBER | VALUE | TOLERANCE | DIELECTRIC MATERIAL | PACKAGE SIZE | RATED WORKING VOLTAGE |
|--------------|----------------|--------|-----------|---------------------|--------------|-----------------------|
| Kemet | C1206C255K8RAC | 2.2µF | ±10% | X7R | 1206 | 10V |
| | C1206C224K8RAC | 0.22µF | ±10% | X7R | 1206 | 10V |
| Panasonic | ECJ3YB1A225K | 2.2µF | ±10% | X7R | 1206 | 10V |
| | ECJ3VB1C224K | 0.22µF | ±10% | X7R | 1206 | 16V |
| Taiyo Yuden | LMK325BJ106KN | 10µF | ±10% | X5R | 1210 | 10V |
| | EMK316BJ225KL | 2.2µF | ±10% | X7R | 1206 | 16V |
| | TKM316BJ224KF | 0.22µF | ±10% | X7R | 1206 | 25V |

TABLE I. Capacitors That Have Been Successfully Used With The REG711.

PACKAGING INFORMATION

| Orderable Device | Status ⁽¹⁾ | Package Type | Package Drawing | Pins | Package Qty | Eco Plan ⁽²⁾ | Lead/Ball Finish | MSL Peak Temp ⁽³⁾ |
|--------------------|-----------------------|--------------|-----------------|------|-------------|-------------------------|------------------|------------------------------|
| REG711EA-2.5/250 | ACTIVE | MSOP | DGK | 8 | 250 | Green (RoHS & no Sb/Br) | CU NIPDAU | Level-2-260C-1 YEAR |
| REG711EA-2.5/250G4 | ACTIVE | MSOP | DGK | 8 | 250 | Green (RoHS & no Sb/Br) | CU NIPDAU | Level-2-260C-1 YEAR |
| REG711EA-2.5/2K5 | ACTIVE | MSOP | DGK | 8 | 2500 | Green (RoHS & no Sb/Br) | CU NIPDAU | Level-2-260C-1 YEAR |
| REG711EA-2.5/2K5G4 | ACTIVE | MSOP | DGK | 8 | 2500 | Green (RoHS & no Sb/Br) | CU NIPDAU | Level-2-260C-1 YEAR |
| REG711EA-2.7/2K5 | ACTIVE | MSOP | DGK | 8 | 2500 | Green (RoHS & no Sb/Br) | CU NIPDAU | Level-2-260C-1 YEAR |
| REG711EA-2.7/2K5G4 | ACTIVE | MSOP | DGK | 8 | 2500 | Green (RoHS & no Sb/Br) | CU NIPDAU | Level-2-260C-1 YEAR |
| REG711EA-3.3/250 | ACTIVE | MSOP | DGK | 8 | 250 | Green (RoHS & no Sb/Br) | CU NIPDAU | Level-2-260C-1 YEAR |
| REG711EA-3.3/250G4 | ACTIVE | MSOP | DGK | 8 | 250 | Green (RoHS & no Sb/Br) | CU NIPDAU | Level-2-260C-1 YEAR |
| REG711EA-3/250 | ACTIVE | MSOP | DGK | 8 | 250 | Green (RoHS & no Sb/Br) | CU NIPDAU | Level-2-260C-1 YEAR |
| REG711EA-3/250G4 | ACTIVE | MSOP | DGK | 8 | 250 | Green (RoHS & no Sb/Br) | CU NIPDAU | Level-2-260C-1 YEAR |
| REG711EA-3/2K5 | ACTIVE | MSOP | DGK | 8 | 2500 | Green (RoHS & no Sb/Br) | CU NIPDAU | Level-2-260C-1 YEAR |
| REG711EA-3/2K5G4 | ACTIVE | MSOP | DGK | 8 | 2500 | Green (RoHS & no Sb/Br) | CU NIPDAU | Level-2-260C-1 YEAR |
| REG711EA-5/250 | ACTIVE | MSOP | DGK | 8 | 250 | Green (RoHS & no Sb/Br) | CU NIPDAU | Level-2-260C-1 YEAR |
| REG711EA-5/250G4 | ACTIVE | MSOP | DGK | 8 | 250 | Green (RoHS & no Sb/Br) | CU NIPDAU | Level-2-260C-1 YEAR |
| REG711EA-5/2K5 | ACTIVE | MSOP | DGK | 8 | 2500 | Green (RoHS & no Sb/Br) | CU NIPDAU | Level-2-260C-1 YEAR |
| REG711EA-5/2K5G4 | ACTIVE | MSOP | DGK | 8 | 2500 | Green (RoHS & no Sb/Br) | CU NIPDAU | Level-2-260C-1 YEAR |

⁽¹⁾ The marketing status values are defined as follows:

ACTIVE: Product device recommended for new designs.

LIFEBUY: TI has announced that the device will be discontinued, and a lifetime-buy period is in effect.

NRND: Not recommended for new designs. Device is in production to support existing customers, but TI does not recommend using this part in a new design.

PREVIEW: Device has been announced but is not in production. Samples may or may not be available.

OBSOLETE: TI has discontinued the production of the device.

⁽²⁾ Eco Plan - The planned eco-friendly classification: Pb-Free (RoHS), Pb-Free (RoHS Exempt), or Green (RoHS & no Sb/Br) - please check <http://www.ti.com/productcontent> for the latest availability information and additional product content details.

TBD: The Pb-Free/Green conversion plan has not been defined.

Pb-Free (RoHS): TI's terms "Lead-Free" or "Pb-Free" mean semiconductor products that are compatible with the current RoHS requirements for all 6 substances, including the requirement that lead not exceed 0.1% by weight in homogeneous materials. Where designed to be soldered at high temperatures, TI Pb-Free products are suitable for use in specified lead-free processes.

Pb-Free (RoHS Exempt): This component has a RoHS exemption for either 1) lead-based flip-chip solder bumps used between the die and package, or 2) lead-based die adhesive used between the die and leadframe. The component is otherwise considered Pb-Free (RoHS compatible) as defined above.

Green (RoHS & no Sb/Br): TI defines "Green" to mean Pb-Free (RoHS compatible), and free of Bromine (Br) and Antimony (Sb) based flame retardants (Br or Sb do not exceed 0.1% by weight in homogeneous material)

⁽³⁾ MSL, Peak Temp. -- The Moisture Sensitivity Level rating according to the JEDEC industry standard classifications, and peak solder temperature.

Important Information and Disclaimer:The information provided on this page represents TI's knowledge and belief as of the date that it is provided. TI bases its knowledge and belief on information provided by third parties, and makes no representation or warranty as to the accuracy of such information. Efforts are underway to better integrate information from third parties. TI has taken and continues to take reasonable steps to provide representative and accurate information but may not have conducted destructive testing or chemical analysis on incoming materials and chemicals. TI and TI suppliers consider certain information to be proprietary, and thus CAS numbers and other limited information may not be available for release.

In no event shall TI's liability arising out of such information exceed the total purchase price of the TI part(s) at issue in this document sold by TI to Customer on an annual basis.

TAPE AND REEL INFORMATION

QUADRANT ASSIGNMENTS FOR PIN 1 ORIENTATION IN TAPE

*All dimensions are nominal

| Device | Package Type | Package Drawing | Pins | SPQ | Reel Diameter (mm) | Reel Width W1 (mm) | A0 (mm) | B0 (mm) | K0 (mm) | P1 (mm) | W (mm) | Pin1 Quadrant |
|------------------|--------------|-----------------|------|------|--------------------|--------------------|---------|---------|---------|---------|--------|---------------|
| REG711EA-2.5/250 | MSOP | DGK | 8 | 250 | 180.0 | 12.4 | 5.3 | 3.4 | 1.4 | 8.0 | 12.0 | Q1 |
| REG711EA-2.5/2K5 | MSOP | DGK | 8 | 2500 | 330.0 | 12.4 | 5.3 | 3.4 | 1.4 | 8.0 | 12.0 | Q1 |
| REG711EA-2.7/2K5 | MSOP | DGK | 8 | 2500 | 330.0 | 12.4 | 5.3 | 3.4 | 1.4 | 8.0 | 12.0 | Q1 |
| REG711EA-3.3/250 | MSOP | DGK | 8 | 250 | 180.0 | 12.4 | 5.3 | 3.4 | 1.4 | 8.0 | 12.0 | Q1 |
| REG711EA-3/250 | MSOP | DGK | 8 | 250 | 180.0 | 12.4 | 5.3 | 3.4 | 1.4 | 8.0 | 12.0 | Q1 |
| REG711EA-3/2K5 | MSOP | DGK | 8 | 2500 | 330.0 | 12.4 | 5.3 | 3.4 | 1.4 | 8.0 | 12.0 | Q1 |
| REG711EA-5/250 | MSOP | DGK | 8 | 250 | 180.0 | 12.4 | 5.3 | 3.4 | 1.4 | 8.0 | 12.0 | Q1 |
| REG711EA-5/2K5 | MSOP | DGK | 8 | 2500 | 330.0 | 12.4 | 5.3 | 3.4 | 1.4 | 8.0 | 12.0 | Q1 |

TAPE AND REEL BOX DIMENSIONS

*All dimensions are nominal

| Device | Package Type | Package Drawing | Pins | SPQ | Length (mm) | Width (mm) | Height (mm) |
|------------------|--------------|-----------------|------|------|-------------|------------|-------------|
| REG711EA-2.5/250 | MSOP | DGK | 8 | 250 | 190.5 | 212.7 | 31.8 |
| REG711EA-2.5/2K5 | MSOP | DGK | 8 | 2500 | 346.0 | 346.0 | 29.0 |
| REG711EA-2.7/2K5 | MSOP | DGK | 8 | 2500 | 346.0 | 346.0 | 29.0 |
| REG711EA-3.3/250 | MSOP | DGK | 8 | 250 | 190.5 | 212.7 | 31.8 |
| REG711EA-3/250 | MSOP | DGK | 8 | 250 | 190.5 | 212.7 | 31.8 |
| REG711EA-3/2K5 | MSOP | DGK | 8 | 2500 | 346.0 | 346.0 | 29.0 |
| REG711EA-5/250 | MSOP | DGK | 8 | 250 | 190.5 | 212.7 | 31.8 |
| REG711EA-5/2K5 | MSOP | DGK | 8 | 2500 | 346.0 | 346.0 | 29.0 |

IMPORTANT NOTICE

Texas Instruments Incorporated and its subsidiaries (TI) reserve the right to make corrections, modifications, enhancements, improvements, and other changes to its products and services at any time and to discontinue any product or service without notice. Customers should obtain the latest relevant information before placing orders and should verify that such information is current and complete. All products are sold subject to TI's terms and conditions of sale supplied at the time of order acknowledgment.

TI warrants performance of its hardware products to the specifications applicable at the time of sale in accordance with TI's standard warranty. Testing and other quality control techniques are used to the extent TI deems necessary to support this warranty. Except where mandated by government requirements, testing of all parameters of each product is not necessarily performed.

TI assumes no liability for applications assistance or customer product design. Customers are responsible for their products and applications using TI components. To minimize the risks associated with customer products and applications, customers should provide adequate design and operating safeguards.

TI does not warrant or represent that any license, either express or implied, is granted under any TI patent right, copyright, mask work right, or other TI intellectual property right relating to any combination, machine, or process in which TI products or services are used. Information published by TI regarding third-party products or services does not constitute a license from TI to use such products or services or a warranty or endorsement thereof. Use of such information may require a license from a third party under the patents or other intellectual property of the third party, or a license from TI under the patents or other intellectual property of TI.

Reproduction of TI information in TI data books or data sheets is permissible only if reproduction is without alteration and is accompanied by all associated warranties, conditions, limitations, and notices. Reproduction of this information with alteration is an unfair and deceptive business practice. TI is not responsible or liable for such altered documentation. Information of third parties may be subject to additional restrictions.

Resale of TI products or services with statements different from or beyond the parameters stated by TI for that product or service voids all express and any implied warranties for the associated TI product or service and is an unfair and deceptive business practice. TI is not responsible or liable for any such statements.

TI products are not authorized for use in safety-critical applications (such as life support) where a failure of the TI product would reasonably be expected to cause severe personal injury or death, unless officers of the parties have executed an agreement specifically governing such use. Buyers represent that they have all necessary expertise in the safety and regulatory ramifications of their applications, and acknowledge and agree that they are solely responsible for all legal, regulatory and safety-related requirements concerning their products and any use of TI products in such safety-critical applications, notwithstanding any applications-related information or support that may be provided by TI. Further, Buyers must fully indemnify TI and its representatives against any damages arising out of the use of TI products in such safety-critical applications.

TI products are neither designed nor intended for use in military/aerospace applications or environments unless the TI products are specifically designated by TI as military-grade or "enhanced plastic." Only products designated by TI as military-grade meet military specifications. Buyers acknowledge and agree that any such use of TI products which TI has not designated as military-grade is solely at the Buyer's risk, and that they are solely responsible for compliance with all legal and regulatory requirements in connection with such use.

TI products are neither designed nor intended for use in automotive applications or environments unless the specific TI products are designated by TI as compliant with ISO/TS 16949 requirements. Buyers acknowledge and agree that, if they use any non-designated products in automotive applications, TI will not be responsible for any failure to meet such requirements.

Following are URLs where you can obtain information on other Texas Instruments products and application solutions:

Products

| | |
|-----------------------------|--|
| Amplifiers | amplifier.ti.com |
| Data Converters | dataconverter.ti.com |
| DLP® Products | www.dlp.com |
| DSP | dsp.ti.com |
| Clocks and Timers | www.ti.com/clocks |
| Interface | interface.ti.com |
| Logic | logic.ti.com |
| Power Mgmt | power.ti.com |
| Microcontrollers | microcontroller.ti.com |
| RFID | www.ti-rfid.com |
| RF/IF and ZigBee® Solutions | www.ti.com/lprf |

Applications

| | |
|--------------------|--|
| Audio | www.ti.com/audio |
| Automotive | www.ti.com/automotive |
| Broadband | www.ti.com/broadband |
| Digital Control | www.ti.com/digitalcontrol |
| Medical | www.ti.com/medical |
| Military | www.ti.com/military |
| Optical Networking | www.ti.com/opticalnetwork |
| Security | www.ti.com/security |
| Telephony | www.ti.com/telephony |
| Video & Imaging | www.ti.com/video |
| Wireless | www.ti.com/wireless |

Mailing Address: Texas Instruments, Post Office Box 655303, Dallas, Texas 75265
Copyright © 2009, Texas Instruments Incorporated