

STRAIGHT PLUG CRIMP TYPE

R161.092.190

CABLE 8.07/50

Series : N

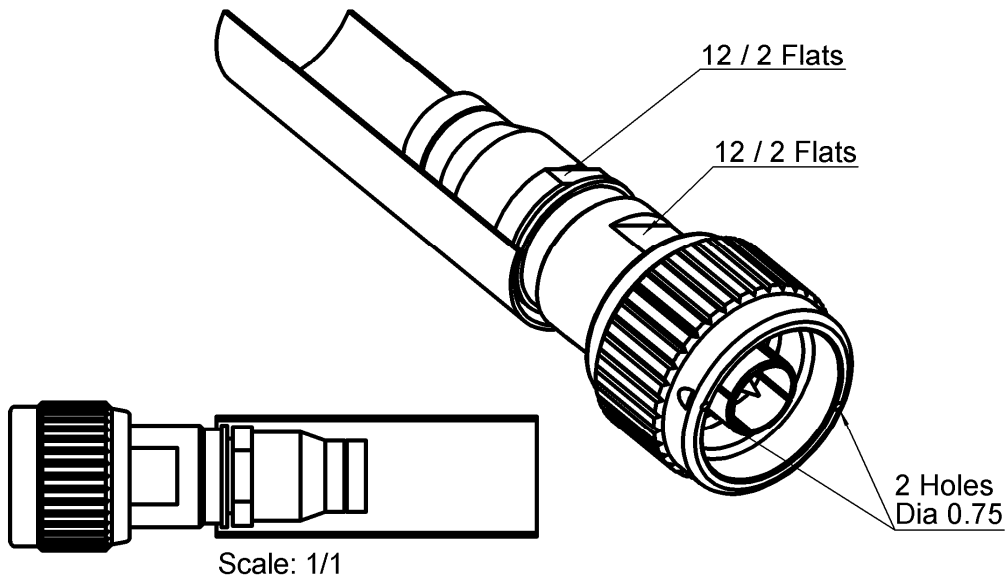
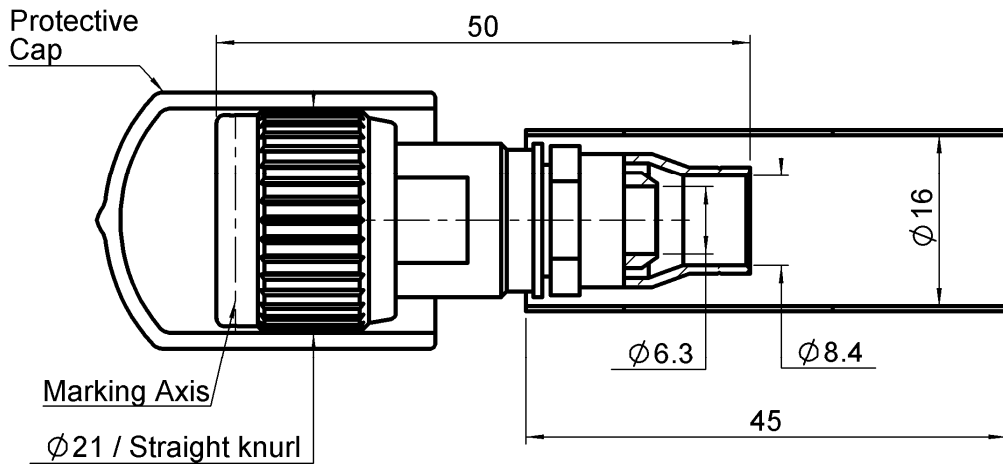

All dimensions are in mm.

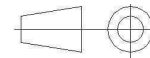

COMPONENTS	MATERIALS	PLATING (μm)
BODY	BRASS	NICKEL 2
CENTER CONTACT	BRASS	GOLD 1.3 OVER NICKEL2
OUTER CONTACT	BRASS	NICKEL 2
INSULATOR	PTFE	
GASKET	SILICONE RUBBER	
OTHERS PARTS	BRASS	NICKEL 2
-	-	-
-	-	-

Issue : 0940 A

In the effort to improve our products, we reserve the right to make changes judged to be necessary.



STRAIGHT PLUG CRIMP TYPE

R161.092.190

CABLE 8.07/50

Series : N

PACKAGING

Standard	Unit	Other
1	-	Contact us

SPECIFICATION

**ASNE0462-F02 -
QAE 06-02**

ELECTRICAL CHARACTERISTICS

Impedance	50	Ω
Frequency	0-3	GHz
VSWR	1.2 + 0,0000	x F(GHz) Maxi
Insertion loss	0.048	\sqrt{F} (GHz) dB Maxi
RF leakage	- (101)	- F(GHz)) dB Maxi
Voltage rating	1000	Veff Maxi
Dielectric withstanding voltage	1500	Veff mini
Insulation resistance	5000	M Ω mini

CABLE ASSEMBLY

Stripping	a	b	c	d	e	f
mm	9,00	9,00	27,0	0,00	0,00	0,00

Assembly instruction :

Recommended cable(s)
ASNE0406-WD
ASNE0692-WN

Characteristics indicated on this data sheet are those that can be achieved with the highest performance cable. Intrinsic limitations of the cable may diminish the performance of the assembly

Cable retention

- pull off	400	N mini
- torque	NA	N.cm

MECHANICAL CHARACTERISTICS

Center contact retention		
Axial force – Mating end	27	N mini
Axial force – Opposite end	27	N mini
Torque	NA	N.cm mini

TOOLING

Part Number	Description	Hexagon
.	.	.
282.247	CRIMPING DIE M 22520/5-61	10.9
282.291	CRIMPING TOOL M22520/1-01	2x4 (loc8)
282.997	POSITIONER FOR TOOL 282.291	Red
R282.293.000	CRIMPING TOOL M22520/5-01	

Recommended torque		
Mating	130	N.cm
Panel nut	NA	N.cm
Clamp nut	370	N.cm
A/F clamp nut	12,0000	mm

Mating life	500	Cycles mini
Weight	45,0240	g

ENVIRONMENTAL

Operating temperature	-65/+165	$^{\circ}$ C
Hermetic seal	NA	Atm.cm3/s
Panel leakage	NA	

OTHER CHARACTERISTICS

Issue : 0940 A

In the effort to improve our products, we reserve the right to make changes judged to be necessary.



STRAIGHT PLUG CRIMP TYPE

R161.092.190

CABLE 8.07/50

Series : N

COMPONENTS

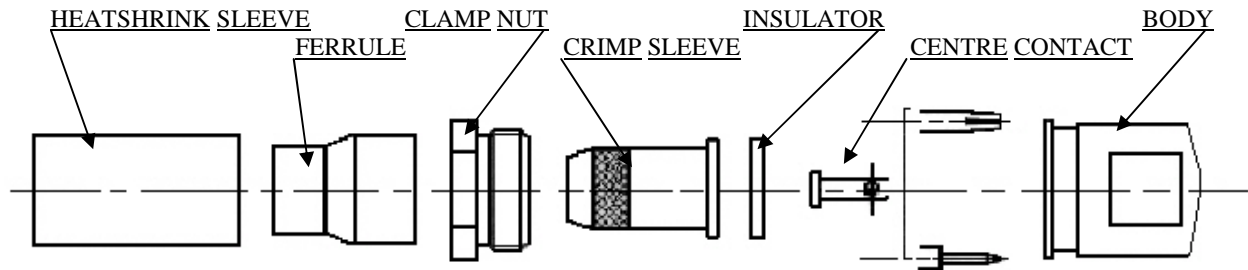

1

Slide onto the cable the heatshrink and the ferrule.
Strip the cable.

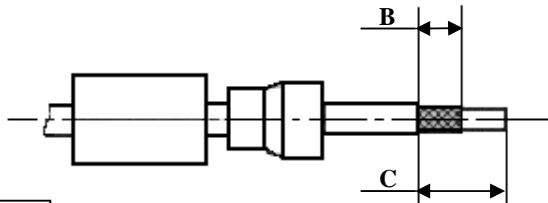

2

Slide the clamp nut onto the crimp sleeve.
Slide sub-assembly under the braid.
Slide ferrule over the braid against clamp nut. (In direction F)
Crimp the ferrule with crimping tool + dies

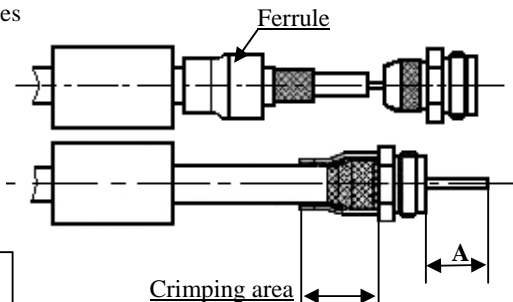

3

Cut the dielectric flush to crimp sleeve.
Mount insulator against crimp sleeve.

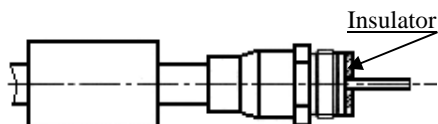

4

Slide the centre contact onto the cable inner conductor against insulator.
Crimp centre contact with the crimping tool and the positioner.

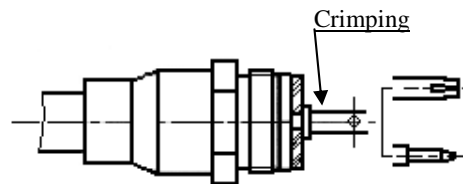

5

Screw sub-assembly into the connector body.
(recommended coupling see the connector TDS)
Slide sleeve over ferrule and heatshrink sleeve in the place.

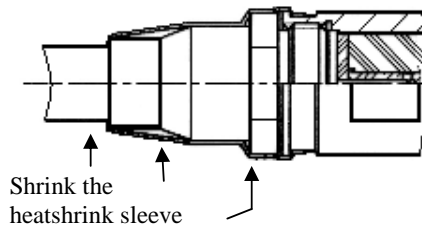

Issue : 0940 A

In the effort to improve our products, we reserve the right to make changes judged to be necessary.

