

## Features

- D<sup>2</sup>PAK housing
- Low inductance
- Resistor electrically isolated from the backplate
- High power rating
- Compatible with lead free solder reflow temperatures

- RoHS compliant\*

## Applications

- Power supplies
- Motor drives
- Test and measurement
- Rectifiers

# PWR263S-35 Series Power Resistor

### General Information

Bourns® PWR263S-35 Series is a TO263 DPAK style power resistor. Manufactured using thick film on alumina ceramic technology, it is used in current measurement, snubber, bleeder and discharge circuits.

### Electrical & Thermal Characteristics

Parameter	Value(s)
Resistance (See table of standard values)	0.02 Ω to 130 KΩ
Power Rating @ 25 °C Case Temperature	35 W
Tolerance	±1 %**, ±5 %
TCR 0.02 Ω < R < 130.0K Ω	±100 PPM/°C
Thermal Resistance - R <sub>thj</sub>	3.7 °C/W
Inductance	0.1 μH maximum
Operating Voltage	√P*R with a maximum of 250 V
Dielectric Strength	2 KV AC
Insulation Resistance	10 GΩ
Operating Temperature	-55 °C to 155 °C

\*\* Available for most values. Check Standard Resistance Values table.

### Reliability Characteristics

Parameter	Specification
Short Term Overload (2x Pr for R < 2 Ω, 1.6 x Pr for R ≥ 2 Ω, V < 1.5 x Operating Voltage)	ΔR ±0.25 %
Load Life (1000 hours at rated power)	ΔR ±1.0 %
Thermal Shock (-55 °C to 155 °C, 5 cycles)	ΔR ±0.5 %
Resistance to Soldering Heat (10 seconds at 270 °C)	ΔR ±0.5 %
Vibration (20 G 10-2000 Hz .06 " D.A.)	ΔR ±0.25 %
Moisture Sensitivity Level	1

### Derating Curve

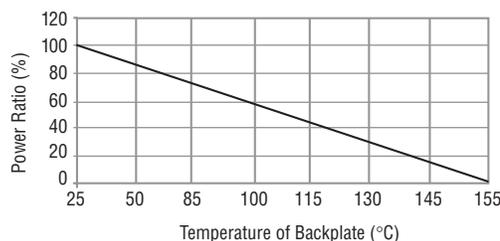

### Material Characteristics

Resistor ..... Thick film  
Substrate ..... Alumina (AL2O3)  
Housing ..... Epoxy  
Pins ..... Tinned Copper (Sn/Cu)  
Flammability ..... Conforms to UL-94V0

### Standard Resistance Values

Code	Resistance Value	Code	Resistance Value
R020	0.02***	20R0	20
R050	0.05***	30R0	30
R100	0.1	33R0	33
R500	0.5	47R0	47
R750	0.75	50R0	50
1R00	1	56R0	56
1R50	1.5	75R0	75
2R00	2	1000	100
2R20	2.2	2000	200
2R50	2.5	3300	330
3R00	3	4700	470
3R30	3.3	7500	7500
4R70	4.7	1001	1000
5R00	5	3301	3300
7R50	7.5	1002	10000
8R20	8.2	3002	33000
10R0	10	1003	100000
15R0	15	1303	130000

\*\*\* 5 % Tolerance

### Typical Part Marking

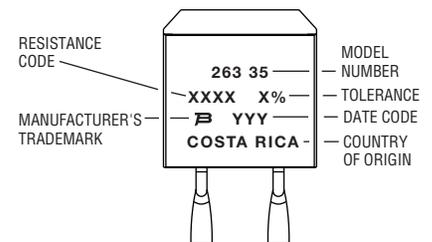

\*RoHS Directive 2002/95/EC Jan 27, 2003 including Annex.  
Specifications are subject to change without notice.  
Customers should verify actual device performance in their specific applications.

# PWR263S-35 Series Power Resistor

**BOURNS®**

## Soldering Profile

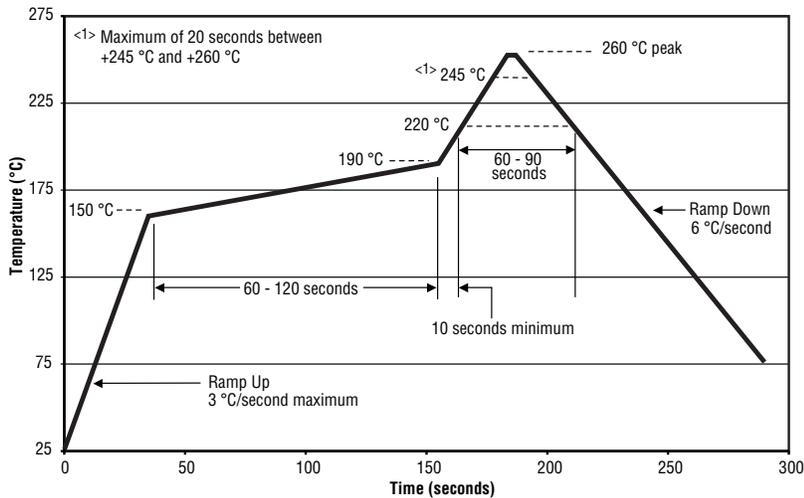

Power dissipation is 2.8 W at an ambient temperature of 25 °C when mounted on a double-sided copper board using FR4 standard, 70 μm of copper, 39 x 30 x 1.6 mm.

## Pulse Power Rating

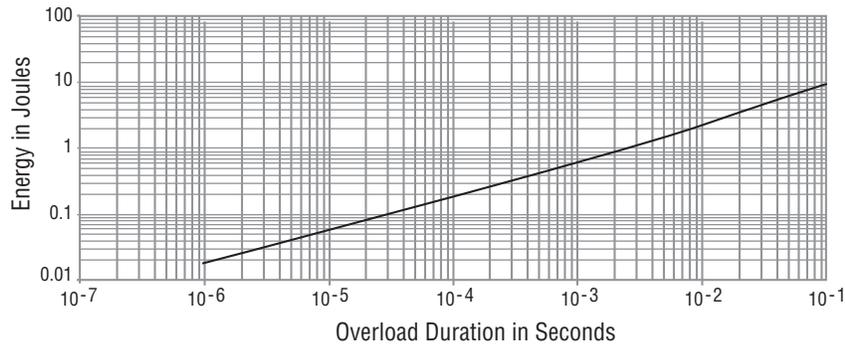

The energy absorbed by the resistor expressed in Joules can be calculated by multiplying the peak power of the pulse in watts times the length of the pulse in seconds.

The energy should not exceed the limits shown in the graph. The overload voltage should not exceed 1.5 times the maximum operating voltage.

## Product Dimensions

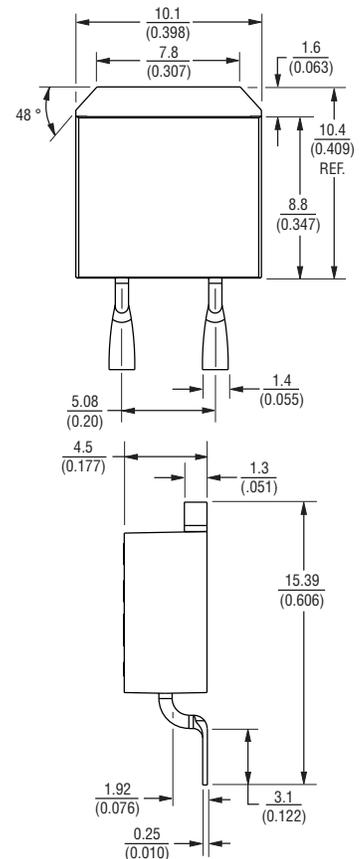

## Recommended Pad Layout

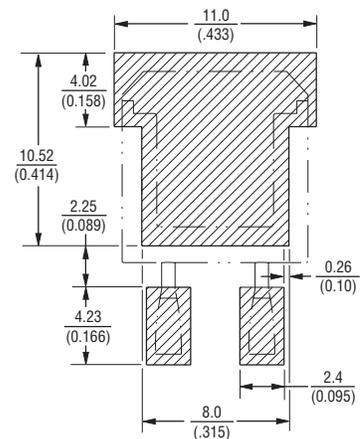

DIMENSIONS:  $\frac{\text{MM}}{\text{(INCHES)}}$

TOLERANCE:  $\frac{\pm 0.38}{(\pm 0.015)}$  UNLESS OTHERWISE NOTED

LEAD 0.102 MAX AT MOUNTING  
COPLANARITY: (0.004) SURFACE

Specifications are subject to change without notice.  
Customers should verify actual device performance in their specific applications.

# PWR263S-35 Series Power Resistor

**BOURNS®**

## How to Order

**PWR 263 S - 35 - 10R0 F E**

Model	_____	_____	_____	_____	_____
PWR = Power Resistor					
Package	_____	_____	_____	_____	_____
263 = D <sup>2</sup> PAK					
Pin Style	_____	_____	_____	_____	_____
S = Surface Mount					
Power	_____	_____	_____	_____	_____
35 = 35 W					
Resistance Value	_____	_____	_____	_____	_____
<100 ohms ... "R" represents decimal point (examples: 7R50 = 7.5 Ω; R500 = 0.5 Ω)					
≥100 ohms ... First three digits are significant, fourth digit represents number of zeros to follow (examples: 2000 = 200 ohms; 3002 = 30K ohms)					
Absolute Tolerance	_____	_____	_____	_____	_____
J = 5 %					
F = 1 %					
Packaging	_____	_____	_____	_____	_____
E = Tape & Reel					
Blank = Tubes					

## Packaging Specifications

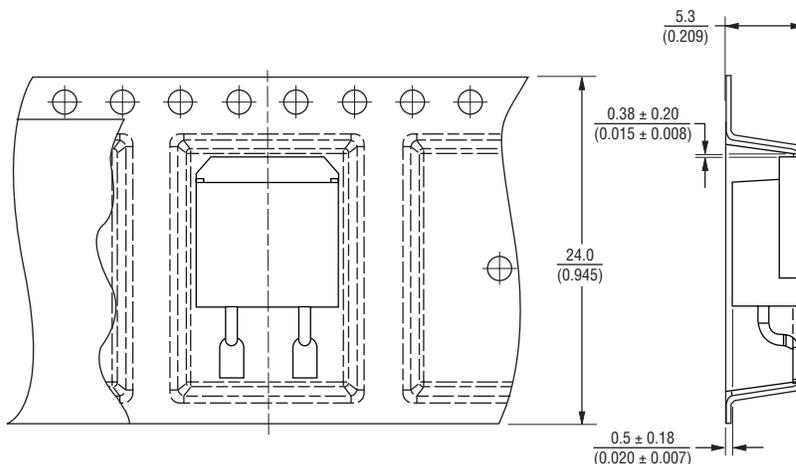

DIMENSIONS:  $\frac{\text{MM}}{\text{(INCHES)}}$

TOLERANCE:  $\frac{\pm 0.38}{(\pm 0.015)}$  UNLESS OTHERWISE NOTED

**BOURNS®**

Asia-Pacific: Tel: +886-2 2562-4117 • Fax: +886-2 2562-4116

Europe: Tel: +41-41 768 5555 • Fax: +41-41 768 5510

The Americas: Tel: +1-951 781-5500 • Fax: +1-951 781-5700

[www.bourns.com](http://www.bourns.com)

03/11

Specifications are subject to change without notice.

Customers should verify actual device performance in their specific applications.