

## 6-60 Volt DC Surface Mount, Resettable PPTC Devices PolyTron™ PTS1206 Series

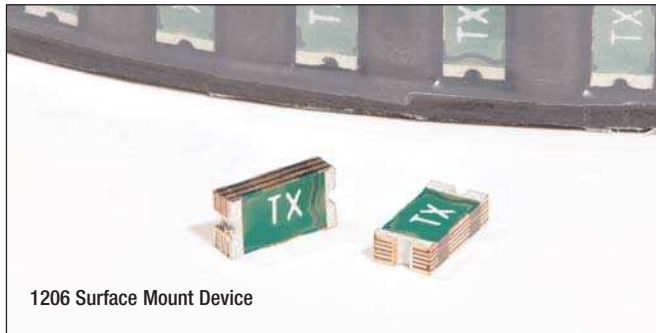

### Description

- Resettable surface mount fuse
- 6 to 60 volts
- Current ratings from 0.05 to 2.0 amps
- Fast time-to-trip
- Low resistance
- Halogen free
- Lead free
- RoHS compliant

### Agency Information

- cURus: Recognized Card: File E343021 (I<sub>hold</sub> 0.05-2.0A)
- TUV File: R 50192872

### Part Number System/Ordering

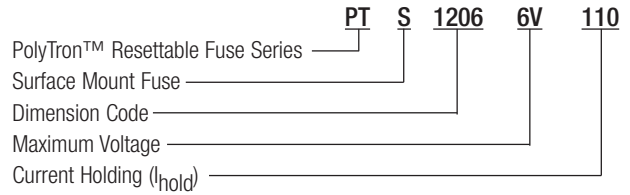

### Tape and Reel Packaging/Quantities

- PTS120630V012, PTS120630V016, PTS120624V020, PTS120616V025, PTS120616V035, PTS12066V050, PTS12066V075 - 5000 fuses per reel
- All others - 2500 fuses per reel

### Applications

- Medical equipment
- White goods
- Telecommunications
- Computers and peripherals
- Rechargeable battery packs

## Specifications

Catalog Number	V <sub>max</sub> (Vdc)	I <sub>max</sub> (Amps)	I <sub>hold</sub> @23°C (Amps)	I <sub>trip</sub> @23°C (Amps)	Pd Typ. (W)	Time to Trip (Max.)		Resistance (Ω)		Agency Information	
						(Amps)	(Sec)	Initial (R <sub>i</sub> )	Post Trip (R <sub>1</sub> )	cURus	TUV
								Min.	Max.		
PTS120660V005	60	100	0.05	0.15	0.4	0.25	1.5	3.6	50	X	X
PTS120660V010	60	100	0.10	0.25	0.4	0.50	1.0	1.6	15	X	X
PTS120630V012	30	100	0.12	0.29	0.5	1.00	0.2	1.4	6	X	X
PTS120630V016	30	100	0.16	0.37	0.5	1.00	0.3	1.1	4.5	X	X
PTS120624V020	24	100	0.20	0.42	0.6	8.00	0.1	0.65	2.6	X	X
PTS120616V025	16	100	0.25	0.50	0.6	8.00	0.08	0.55	2.3	X	X
PTS120616V035	16	100	0.35	0.75	0.6	8.00	0.1	0.3	1.2	X	X
PTS12066V050	6	100	0.50	1.00	0.6	8.00	0.1	0.15	0.7	X	X
PTS120615V050	15	100	0.50	1.00	0.6	8.00	0.1	0.15	0.7	X	X
PTS12066V075	6	100	0.75	1.50	0.6	8.00	0.2	0.1	0.29	X	X
PTS12066V100	6	100	1.00	1.80	0.8	8.00	0.3	0.065	0.21	X	X
PTS12066V110	6	100	1.10	2.20	0.8	8.00	0.3	0.07	0.2	X	X
PTS12066V150	6	100	1.50	3.00	0.8	8.00	1.0	0.04	0.12	X	X
PTS12066V200	6	100	2.00	3.50	1.0	8.00	1.5	0.02	0.08	X	X

Notes: I<sub>hold</sub> – Hold current: Maximum current device will pass without interruption in 23°C still air.  
I<sub>trip</sub> – Trip current: Minimum current that will switch the device from low resistance to high resistance in 23°C still air.  
V<sub>max</sub>: Maximum continuous voltage device can withstand without damage at rated current.  
I<sub>max</sub>: Maximum fault current device can withstand without damage at rated voltage.  
P<sub>d</sub>: Power dissipated from device when in the tripped state in 23°C still air.  
R<sub>i</sub> (min.): Minimum resistance of device as supplied at 23°C unless otherwise specified.  
R<sub>i</sub> (max.): Maximum resistance of device as supplied at 23°C unless otherwise specified.  
R<sub>1</sub> (max.): Maximum resistance of device when measured one hour post reflow (SMD) or one hour post trip (radial-leaded device) at 23°C unless otherwise specified.

Dimensions - mm

Part Number	A		B		C		D		E	
	Min.	Max.	Min.	Max.	Min.	Max.	Min.	Min.	Max.	
PTS120660V005	3.00	3.50	1.50	1.80	0.50	0.90	0.125	0.08	0.45	
PTS120660V010	3.00	3.50	1.50	1.80	0.50	0.90	0.125	0.08	0.45	
PTS120630V012	3.00	3.50	1.50	1.80	0.35	0.90	0.125	0.08	0.45	
PTS120630V016	3.00	3.50	1.50	1.80	0.28	0.68	0.125	0.08	0.45	
PTS120624V020	3.00	3.50	1.50	1.80	0.28	0.68	0.125	0.08	0.45	
PTS120616V025	3.00	3.50	1.50	1.80	0.28	0.68	0.125	0.08	0.45	
PTS120616V035	3.00	3.50	1.50	1.80	0.28	0.68	0.125	0.08	0.45	
PTS12066V050	3.00	3.50	1.50	1.80	0.28	0.68	0.125	0.08	0.45	
PTS120615V050	3.00	3.50	1.50	1.80	0.28	1.06	0.125	0.08	0.45	
PTS12066V075	3.00	3.50	1.50	1.80	0.28	0.85	0.125	0.08	0.45	
PTS12066V100	3.00	3.50	1.50	1.80	0.40	0.88	0.125	0.08	0.45	
PTS12066V110	3.00	3.50	1.50	1.80	0.40	0.88	0.125	0.08	0.45	
PTS12066V150	3.00	3.50	1.50	1.80	0.55	1.15	0.125	0.08	0.45	
PTS12066V200	3.00	3.50	1.50	1.80	0.55	1.15	0.125	0.08	0.45	

1206 Package

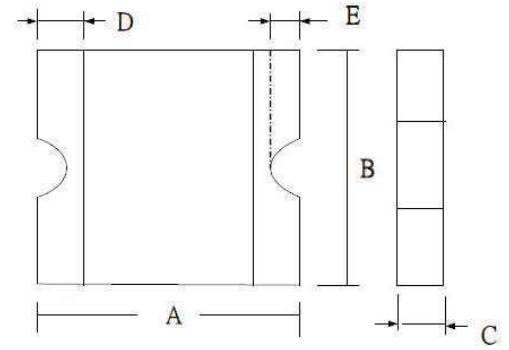

Time-to-Trip Curves at 23°C

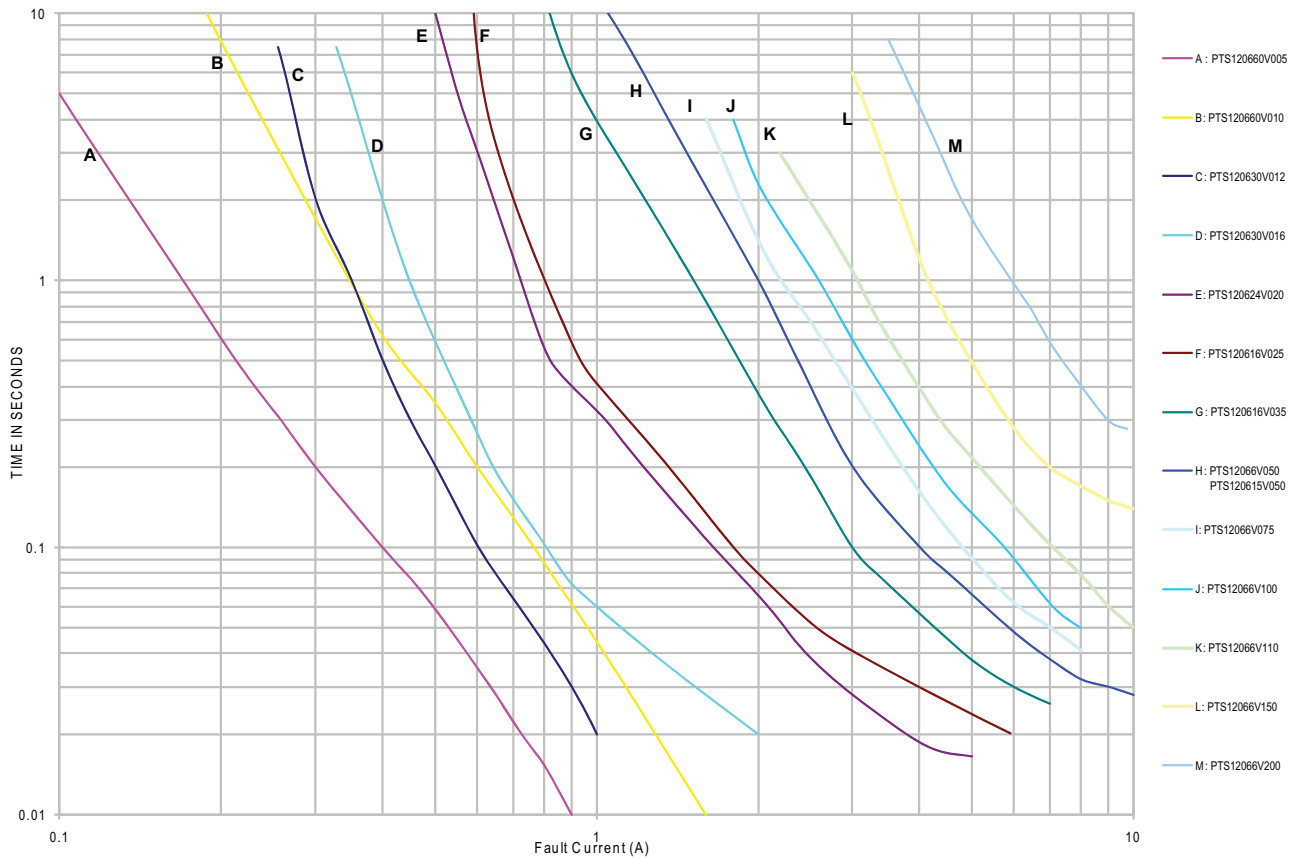

## Thermal Derating Curve

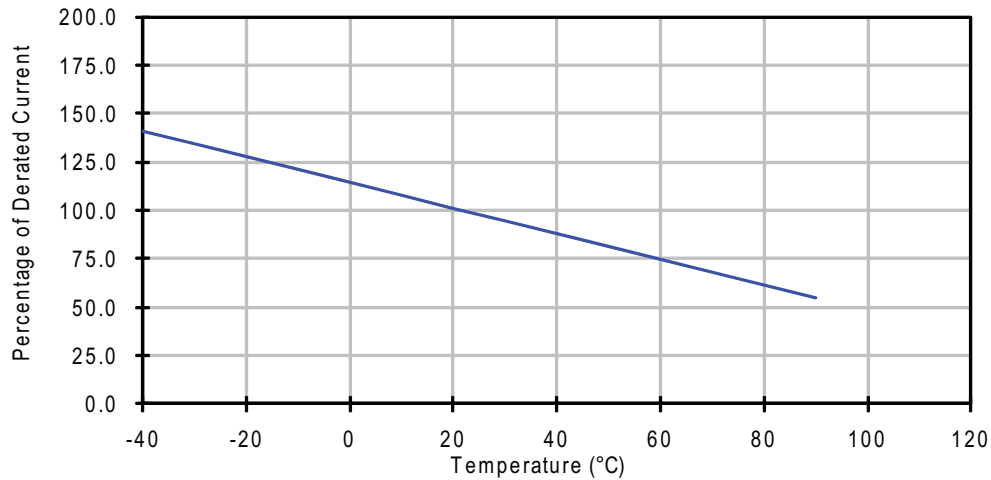

## Soldering Methods

- Wave Solder
  - Reservoir Temperature: 260°C (500°F)
  - Recommended time in reservoir: 10 seconds.
- Infrared Reflow
  - Temperature: 260°C
  - Time: 10 seconds maximum at peak temperature.

## Recommended Wave Solder Profile

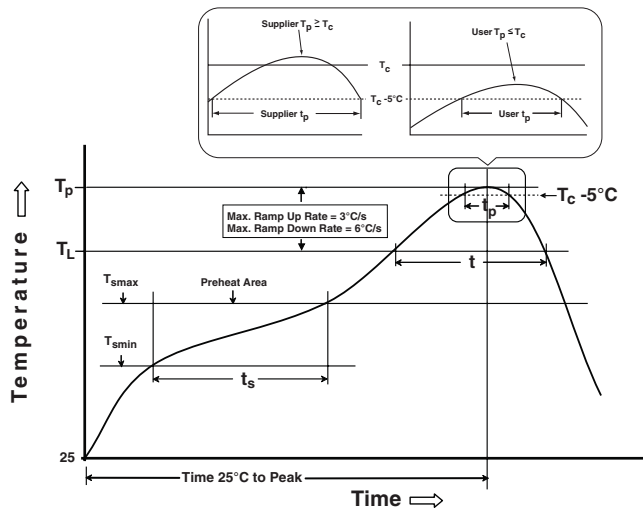

## Environmental Specifications

Characteristic	Value
Operating Temperature Range	-40°C to +85°C
Surface Temperature Trip State	125°C max.
Thermal Shock	+85°C to -40°C, 10 cycles, 5% typical resistance change
Solvent Resistance	MIL-STD-202 Method 215, no change
Humidity Age Test	+85°C, 85% RH, 1000 hours ±5% typical resistance change. Specified temperature (23°C ± 3°C)
Storage Temperature Range	-10°C to +40°C
Storage Duration	One year
Storage Relative Humidity	≤75%
Storage Conditions	Keep away from corrosive atmosphere and sunlight

## Recommended Land Pattern - mm (in)

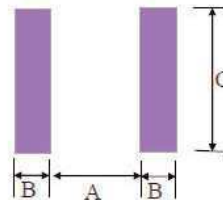

A	B	C
2.0 (0.079)	1.0 (0.039)	1.9 (0.075)

## Material Composition

- Terminal material: Nickel/tin-plated copper

Profile Feature	Sn-Pb Eutectic Assembly	Pb-Free Assembly
<b>Preheat &amp; Soak</b>		
Temperature min ( $T_{smin}$ )	100°C	150°C
Temperature max ( $T_{smax}$ )	150°C	200°C
Time ( $T_{smin}$ to $T_{smax}$ ) ( $t_s$ )	60-120 seconds	60-120 seconds
Average ramp-up rate ( $T_{smax}$ to $T_p$ )	3°C/second max.	3°C/second max.
Liquidous temperature ( $T_L$ )	183°C	217°C
Time at liquidous ( $t_l$ )	60-150 seconds	60-150 seconds
Peak package body temperature ( $T_p$ )*	See classification temp in Table 4.1	See classification temp in Table 4.2
Time ( $t_p$ )** within 5°C of the specified classification temperature ( $T_c$ )	20** seconds	30** seconds
Average ramp-down rate ( $T_p$ to $T_{smax}$ )	6°C/second max.	6°C/second max.
Time 25°C to peak temperature	6 minutes max.	8 minutes max.
* Tolerance for peak profile temperature ( $T_p$ ) is defined as a supplier minimum and a user maximum.		
** Tolerance for time at peak profile temperature ( $t_p$ ) is defined as a supplier minimum and a user maximum.		

## Packaging Specifications

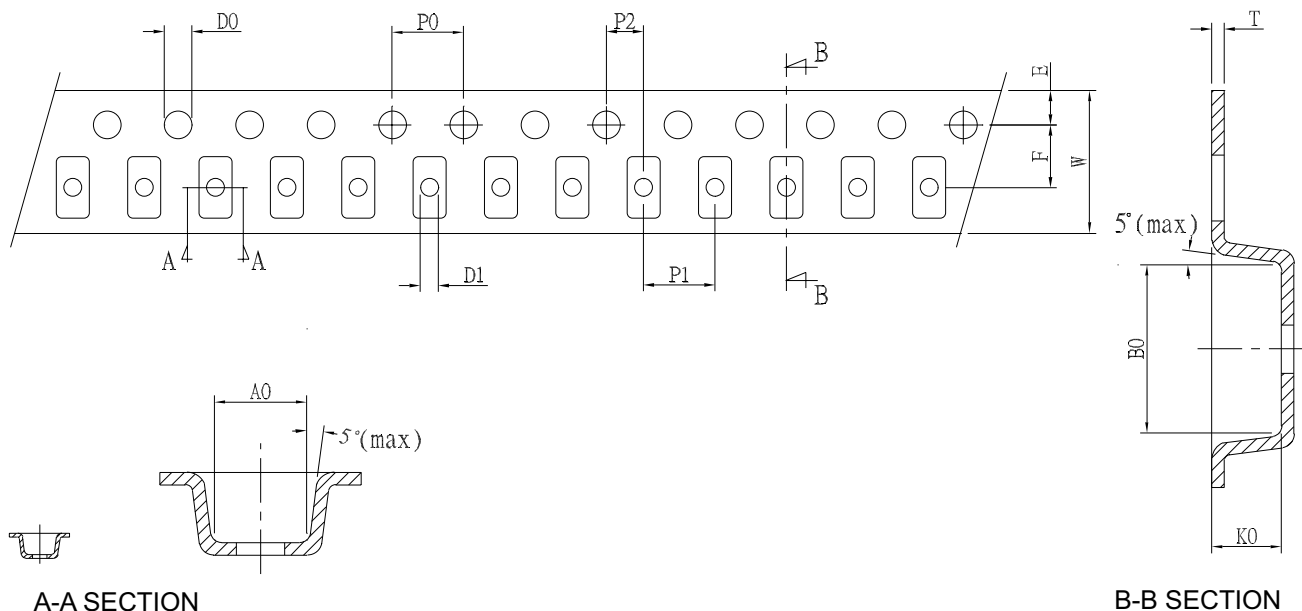

For PTS120660V005, PTS120660V010, PTS120615V050, PTS12066V100, PTS12066V110, PTS12066V150, PTS12066V200													
Index	A0	B0	K0	P0	P1	P2	T	E	F	D0	D1	W	10P0
Type	±0.1	±0.1	±0.1	±0.1	±0.1	±0.05	±0.05	±0.1	±0.05	+0.1/-0	Min.	±0.1	±0.2
1206	1.95	3.55	1.35	4.0	4.0	2.0	0.25	1.75	3.5	1.5	1.0	8.1	40.0
For PTS120630V012, PTS120630V016, PTS120624V020, PTS120616V025, PTS120616V035, PTS12066V050, PTS12066V075													
Index	A0	B0	K0	P0	P1	P2	T	E	F	D0	D1	W	10P0
Type	±0.1	±0.1	±0.1	±0.1	±0.1	±0.05	±0.1	±0.1	±0.05	±0.05	Min.	±0.3	±0.2
1206	1.85	3.45	0.74	4.0	4.0	2.0	0.25	1.75	3.5	1.55	1.0	8.0	40.0

## Reel Specifications

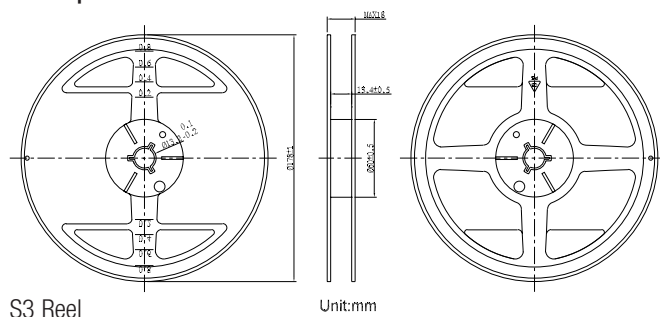

The only controlled copy of this Data Sheet is the electronic read-only version located on the Cooper Bussmann Network Drive. All other copies of this document are by definition uncontrolled. This bulletin is intended to clearly present comprehensive product data and provide technical information that will help the end user with design applications. Cooper Bussmann reserves the right, without notice, to change design or construction of any products and to discontinue or limit distribution of any products. Cooper Bussmann also reserves the right to change or update, without notice, any technical information contained in this bulletin. Once a product has been selected, it should be tested by the user in all possible applications.

Life Support Policy: Cooper Bussmann does not authorize the use of any of its products for use in life support devices or systems without the express written approval of an officer of the Company. Life support systems are devices which support or sustain life, and whose failure to perform, when properly used in accordance with instructions for use provided in the labeling, can be reasonably expected to result in significant injury to the user.