

**4-Bit BusSwitch with
-2V Undershoot Protection**

Product Features

- R_{ON} is 5ohm typical
- Undershoot protection on A port only: -2V
- Direct bus connection when switches are ON
- Industrial Operation Temperature: -40°C to +85°C
- Near zero propagation delay
- Low Channel ON Capacitance: 14pF max.
- Packages available:
 - 14-pin 173 mil wide plastic TSSOP(L)
 - 14-pin 150 mil wide plastic SOIC (W)
 - 16-pin 150 mil wide plastic QSOP (Q)

Applications

- PCI Hot Plugging for live insertion
- Memory bank sharing

Product Description

Pericom Semiconductor's PI5C series of logic circuits are produced using the Company's advanced submicron CMOS technology, achieving industry leading performance.

The PI5C3125C and PI5C3126C are 5V, 4-bit, 2-port bus switches. They are intended for PCI Hot-Plug applications. Industry leading advantages include a propagation delay of 250ps, resulting from its 5-ohm channel resistance and low I/O capacitance. The A-ports switch data to B outputs and are bidirectional. The PI5C3125C device has active LOW enables, and the PI5C3126C has active HIGH enables.

The A-port can handle up to -2V undershoot when the switch is disabled.

PI5C3125C Logic Block Diagram

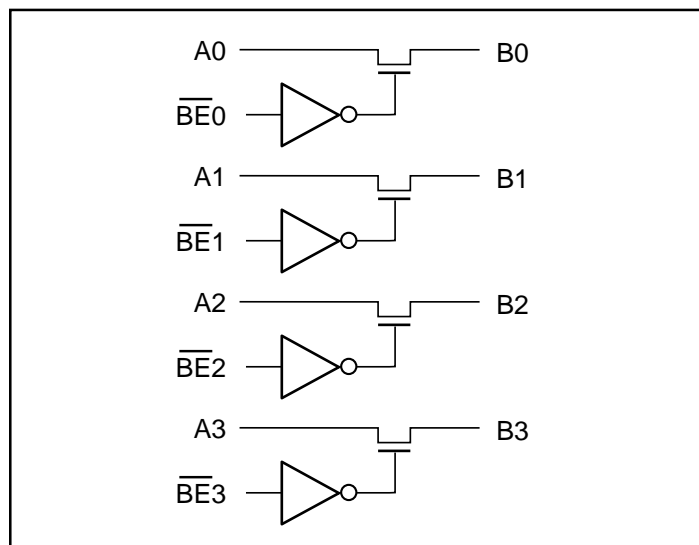

PI5C3126C Logic Block Diagram

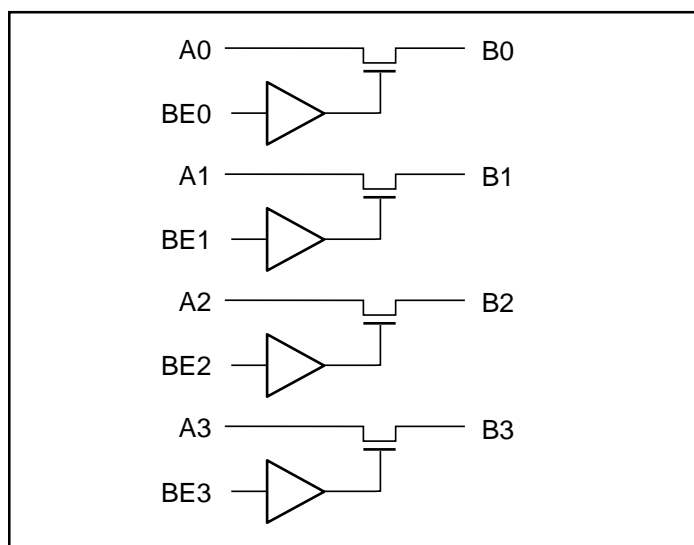

PI5C3125 14-Pin Configuration

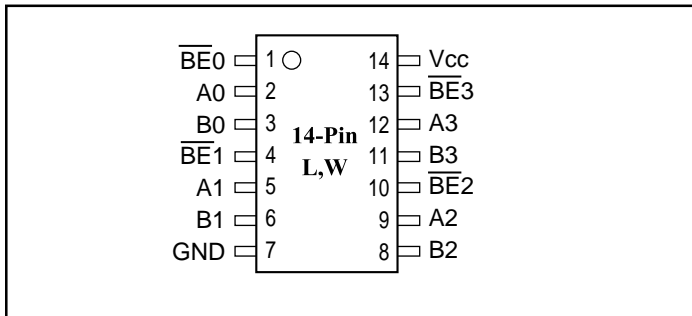

PI5C3126 14-Pin Configuration

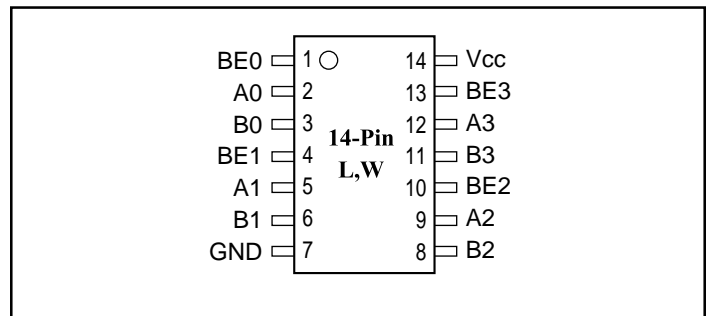

PI5C3125 16-Pin Configuration

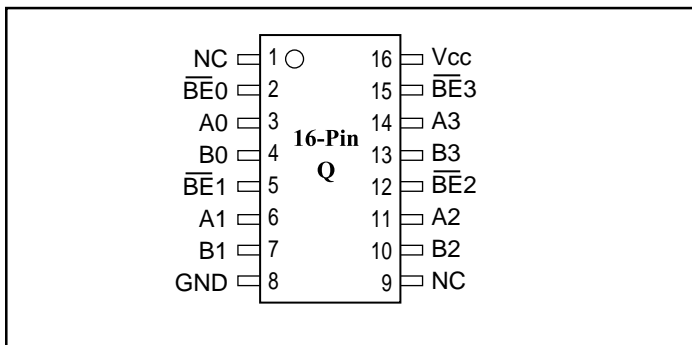

PI5C3126 16-Pin Configuration

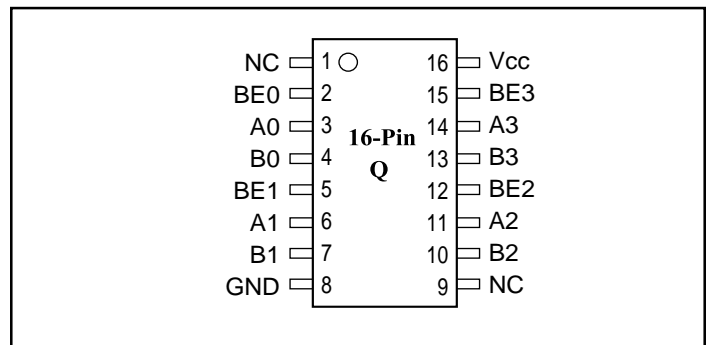

Product Pin Description

Pin Name	Description
\overline{BE}_n	Switch Enable (PI5C3125C)
BE_n	Switch Enable (PI5C3126C)
A3-A0	Bus A
B3-B0	Bus B
V_{CC}	Power
GND	Ground

Truth Table⁽¹⁾

PI5C3125C	PI5C3126C	A_n	B_n	V_{CC}	Function
X^*	X	Hi-Z	Hi-Z	GND	Disconnect
H	L	Hi-Z	Hi-Z	V_{CC}	Disconnect
L	H	B_n	A_n	V_{CC}	Connect

Notes:

- H = High Voltage Level, L = Low Voltage Level
 Hi-Z = High Impedance, X = Don't Care
- * A pull-up resistor should be provided for power-up protection.

Maximum Ratings

(Above which the useful life may be impaired. For user guidelines, not tested.)

Storage Temperature	-65°C to +150°C
Ambient Temperature with Power Applied	-40°C to +85°C
Supply Voltage to Ground Potential (Inputs & V_{CC} Only)	-0.5V to +7.0V
Supply Voltage to Ground Potential (Outputs & D/O Only)	-0.5V to +7.0V
DC Input Voltage	-0.5V to +7.0V
DC Output Current	120mA
Power Dissipation	0.5W

Note:

Stresses greater than those listed under MAXIMUM RATINGS may cause permanent damage to the device. This is a stress rating only and functional operation of the device at these or any other conditions above those indicated in the operational sections of this specification is not implied. Exposure to absolute maximum rating conditions for extended periods may affect reliability.

DC Electrical Characteristics (Over the Operating Range, $T_A = -40^\circ\text{C}$ to $+85^\circ\text{C}$, $V_{CC} = 5\text{V} \pm 10\%$)

Parameters	Description	Test Conditions ⁽¹⁾	Min.	Typ ⁽²⁾	Max.	Units
V_{IH}	Input HIGH Voltage	Guaranteed Logic HIGH Level	2.0			V
V_{IL}	Input LOW Voltage	Guaranteed Logic LOW Level	-0.5		0.8	V
I_{IH}	Input HIGH Current	$V_{CC} = \text{Max.}, V_{IN} = V_{CC}$			± 1	μA
I_{IL}	Input LOW Current	$V_{CC} = \text{Max.}, V_{IN} = \text{GND}$			± 1	μA
I_{OZH}	High Impedance Output Current	$0 \leq A, B \leq V_{CC}$			± 1	μA
V_{IK}	Clamp Diode Voltage	$V_{CC} = \text{Min.}, I_{IN} = -18\text{mA}$			-1.8	V
V_{UP}	Undershoot Protection Voltage ⁽³⁾	Max Inputs, Undershoot Pulse Duration $< 25\text{ns}$			-2.0	V
R_{ON}	Switch On Resistance ⁽⁴⁾	$V_{CC} = \text{Min.}, V_{IN} = 0.0\text{V}, I_{ON} = 48\text{mA}$ $V_{CC} = \text{Min.}, V_{IN} = 2.4\text{V}, I_{ON} = 15\text{mA}$		5 10	7 15	ohm

Capacitance ($T_A = 25^\circ\text{C}$, $f = 1\text{MHz}$)

Parameters ⁽⁵⁾	Description	Test Conditions	Typ.	Max.	Units
C_{IN}	Input Capacitance	$V_{IN} = 0\text{V}$		6	pF
C_{OFF}	A/B Capacitance, Switch Off	$V_{IN} = 0\text{V}$		6	pF
C_{ON}	A/B Capacitance, Switch On	$V_{IN} = 0\text{V}$		8	pF

Notes:

- For Max. or Min. conditions, use appropriate value specified under Electrical Characteristics for the applicable device type.
- Typical values are at $V_{CC} = 5.0\text{V}$, $T_A = 25^\circ\text{C}$ ambient and maximum loading.
- Not more than one output should be shorted at one time. Duration of the test should not exceed one second.
- Measured by the voltage drop between A and B pin at indicated current through the switch. ON resistance is determined by the lower of the voltages on the two (A, B) pins.
- This parameter is determined by device characterization but is not production tested.

Power Supply Characteristics

Parameters	Description	Test Conditions ⁽¹⁾		Min.	Typ ⁽²⁾	Max.	Units
I_{CC}	Quiescent Power Supply Current	$V_{CC} = \text{Max.}$	$V_{IN} = \text{GND or } V_{CC}$			100	μA
ΔI_{CC}	Supply Current per Input @ TTL HIGH	$V_{CC} = \text{Max.}$	$V_{IN} = 3.4\text{V}^{(3)}$			2.5	mA

Notes:

- For Max. or Min. conditions, use appropriate value specified under Electrical Characteristics for the applicable device.
- Typical values are at $V_{CC} = 5.0\text{V}$, $+25^\circ\text{C}$ ambient.
- Per TTL driven input ($V_{IN} = 3.4\text{V}$, control inputs only); A and B pins do not contribute to I_{CC} .
- This current applies to the control inputs only and represent the current required to switch internal capacitance at the specified frequency.
The A and B inputs generate no significant AC or DC currents as they transition. This parameter is not tested, but is guaranteed by design.

PI5C3125C Switching Characteristics over Operating Range

Parameters	Description	Conditions	PI5C3125C		Units
			Com		
			Min.	Max.	
t_{PLH} t_{PHL}	Propagation Delay ^(2,3) A to B, B to A	$C_L = 50pF$ $R_L = 500ohm$		0.25	ns
t_{PZH} t_{PZL}	Bus Enable Time		0.5	6.6	
t_{PHZ} t_{PLZ}	Bus Disable Time		0.5	6.0	

PI5C3126C Switching Characteristics over Operating Range

Parameters	Description	Conditions	PI5C3126C		Units
			Com		
			Min.	Max.	
t_{PLH} t_{PHL}	Propagation Delay ^(2,3) A to B, B to A	$C_L = 50pF$ $R_L = 500ohm$		0.25	ns
t_{PZH} t_{PZL}	Bus Enable Time		0.5	6.6	
t_{PHZ} t_{PLZ}	Bus Disable Time		0.5	6.0	

Notes:

1. See test circuit and wave forms.
2. This parameter is guaranteed but not tested on Propagation Delays.
3. The bus switch contributes no propagational delay other than the RC delay of the ON resistance of the switch and the load capacitance. The time constant for the switch alone is of the order of 0.25ns for 50pF load. Since this time constant is much smaller than the rise/fall times of typical driving signals, it adds very little propagational delay to the system. Propagational delay of the bus switch when used in a system is determined by the driving circuit on the driving side of the switch and its interaction with the load on the driven side.

Applications Information

Logic Inputs

The logic control inputs can be driven up to +5.5V regardless of the supply voltage. For example, given a +5.0V supply, BE, may be driven LOW to 0V and HIGH to 5.5V. Driving BE Rail-to-Rail[®] minimizes power consumption.

Power-Supply Sequencing

Proper power-supply sequencing is recommended for all CMOS devices. Always apply Vcc before applying signals to the input/output or control pins.

[®]Rail-to-Rail is a registered trademark of Nippon Motorola, Ltd.

14-Pin SOIC (W)

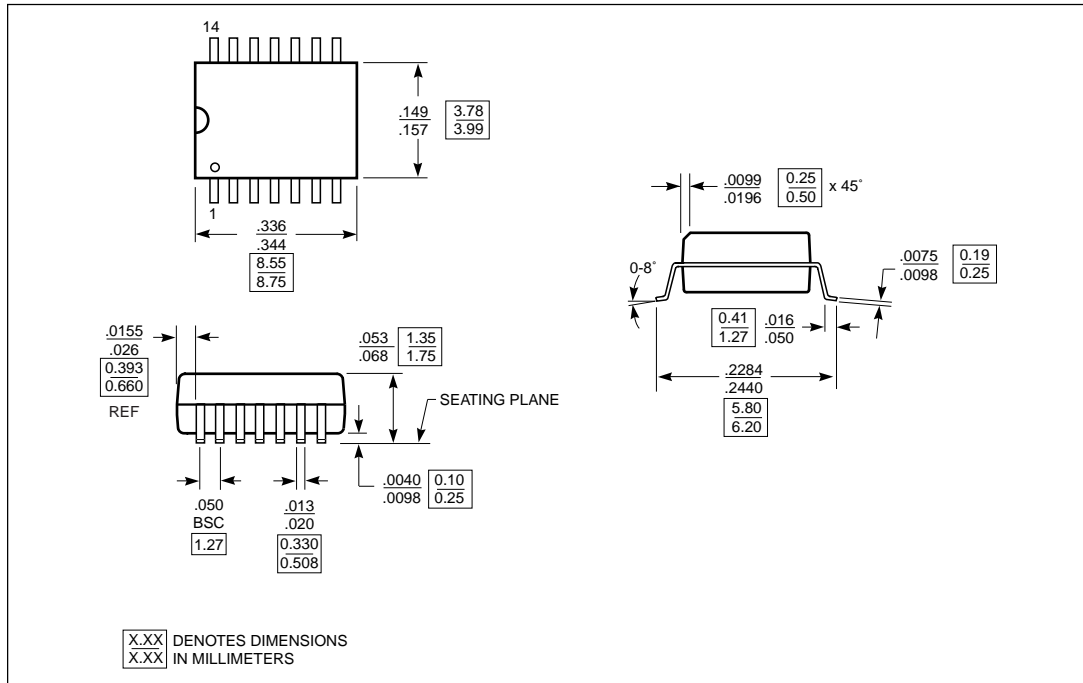

16-Pin QSOP (Q)

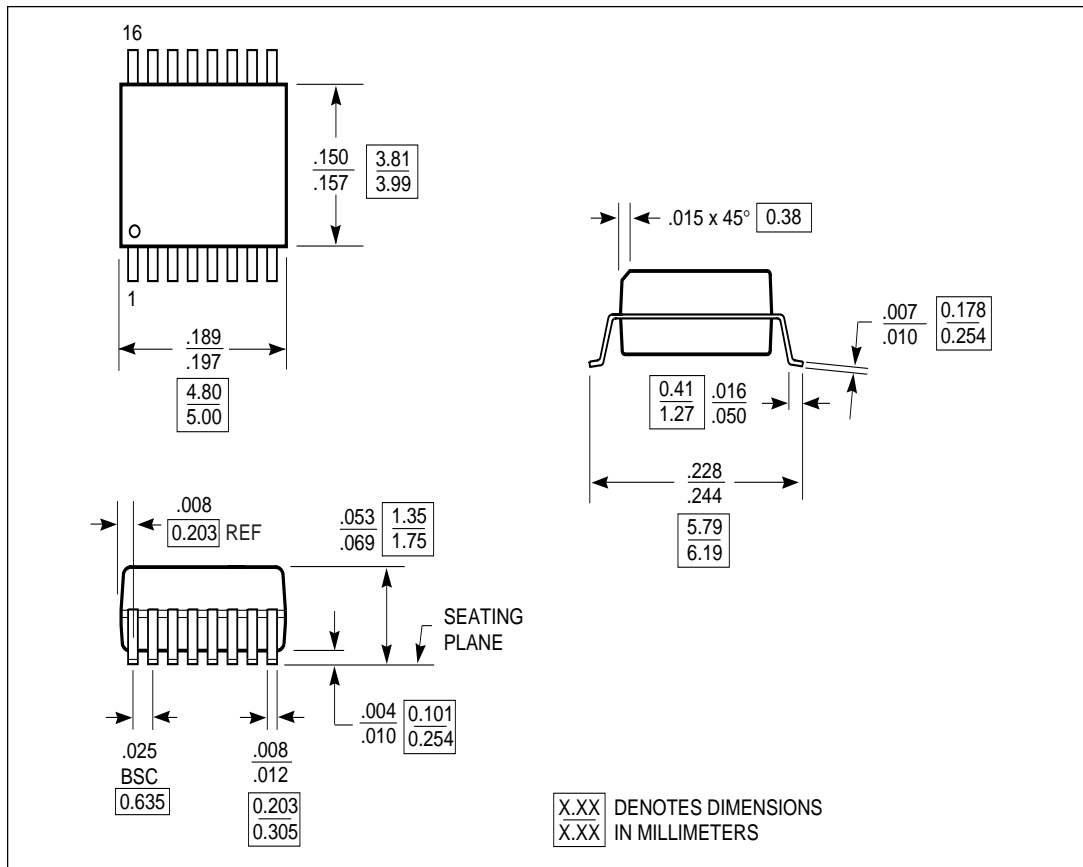

14-Pin TSSOP (L)

