

DATA SHEET

TDA837x family
I²C-bus controlled economy
PAL/NTSC and NTSC
TV-processors

Preliminary specification
File under Integrated Circuits, IC02

1997 Jul 01

I²C-bus controlled economy PAL/NTSC and NTSC TV-processors

TDA837x family

FEATURES

Available in all ICs:

- Vision IF amplifier with high sensitivity and good figures for differential phase and gain
- PLL demodulator for the IF signal
- Alignment-free sound demodulator
- Flexible source selection with a CVBS input for the internal signal and Y/C or CVBS input for the external signal
- Audio switch
- The output signal of the CVBS (Y/C) switch is externally available
- Integrated chrominance trap and band-pass filters (auto-calibrated)
- Luminance delay line integrated
- A symmetrical peaking circuit in the luminance channel
- Black stretching of non-standard CVBS or luminance signals
- RGB control circuit with black current stabilization and white point adjustment
- Linear RGB inputs and fast blanking
- Horizontal synchronization with two control loops and alignment-free horizontal oscillator
- Slow start and slow stop of the horizontal drive pulses
- Vertical count-down circuit
- Vertical driver optimized for DC-coupled vertical output stages
- I²C-bus control of various functions
- Low dissipation
- Small amount of peripheral components compared with competition ICs.



GENERAL DESCRIPTION

The various versions of the TDA837x series are I²C-bus controlled single-chip TV processors which are intended to be applied in PAL/NTSC (TDA8374 and TDA8375) and NTSC (TDA8373 and TDA8377) television receivers. All ICs are available in an SDIP56 package and some versions are also available in a QFP64 package. The ICs are pin compatible so that with one application board NTSC and PAL/NTSC (or multistandard together with the SECAM decoder TDA8395) receivers can be built.

Functionally this IC series is split in to 2 categories:

- Versions intended to be used in economy TV receivers with all basic functions
- Versions with additional functions such as E-W geometry control, horizontal and vertical zoom function and YUV interface which are intended for TV receivers with 110° picture tubes.

The various type numbers are given in Table 1.

The detailed differences between the various ICs are given in Table 2.

Table 1 TV receiver versions

TV RECEIVERS	SDIP56 PACKAGE		QFP64 PACKAGE	
	ECONOMY	MID/HIGH END	ECONOMY	MID/HIGH END
PAL only	TDA8374B	–	TDA8374BH	–
PAL/NTSC (SECAM)	TDA8374 and TDA8374A	TDA8375 and TDA8375A	TDA8374AH	TDA8375AH
NTSC	TDA8373	TDA8377 and TDA8377A	–	–

I²C-bus controlled economy PAL/NTSC and NTSC TV-processors

TDA837x family

Table 2 Differences between the various ICs

CIRCUITS	IC VERSION (TDA)							
	8373	8374	8374A(H)	8374B(H)	8375	8375A(H)	8377	8377A
Multistandard IF	–	X	–	–	X	X	–	–
Automatic Volume Levelling (AVL)	X	X	–	–	–	–	–	–
PAL decoder	–	X	X	X	X	X	–	–
SECAM interface	–	X	X	X	X	X	–	–
NTSC decoder	X	X	X	X	X	X	X	X
Colour matrix PAL/NTSC (Japan)	–	X	X	X	X	X	–	–
Colour matrix NTSC (USA/Japan)	X	–	–	–	–	–	X	X
YUV interface	–	–	–	–	X	X	X	X
Horizontal geometry	–	–	–	–	X	X	X	X
Horizontal and vertical zoom	–	–	–	–	X	X	X	X

QUICK REFERENCE DATA

SYMBOL	PARAMETER	CONDITIONS	MIN.	TYP.	MAX.	UNIT
Supplies						
V _P	supply voltage		–	8.0	–	V
I _P	supply current		–	110	–	mA
Input voltages						
V _{48,49(rms)}	video IF amplifiers sensitivity (RMS value)		–	70	–	μV
V _{1(rms)}	sound IF amplifiers sensitivity (RMS value)		–	1.0	–	mV
V _{2(rms)}	external audio input voltage (RMS value)		–	500	–	mV
V _{11(p-p)}	external CVBS/Y input voltage (peak-to-peak value)		–	1.0	–	V
V _{10(p-p)}	external chrominance input voltage (burst amplitude) (peak-to-peak value)		–	0.3	–	V
V _{23-25(p-p)}	RGB input voltage (peak-to-peak value)		–	0.7	–	V
Output signals						
V _{6(p-p)}	IF video output voltage (peak-to-peak value)		–	2.5	–	V
I ₅₄	tuner AGC output current range		0	–	5	mA
V _{oVSW}	output signal level of video switch (peak-to-peak value)		–	1.0	–	V
V _{30(p-p)}	–(R – Y) output voltage (peak-to-peak value)		–	525	–	mV

I²C-bus controlled economy PAL/NTSC and NTSC TV-processors

TDA837x family

SYMBOL	PARAMETER	CONDITIONS	MIN.	TYP.	MAX.	UNIT
V _{29(p-p)}	-(B - Y) output voltage (peak-to-peak value)		-	675	-	mV
V _{28(p-p)}	luminance output voltage (peak-to-peak value)		-	1.4	-	V
V _{19-21(p-p)}	RGB output signal amplitudes (peak-to-peak value)		-	2.0	-	V
I ₄₀	horizontal output current		-	10	-	mA
I _{46,47(p-p)}	vertical output current (peak-to-peak value)		-	1	-	mA
I _{45(peak)}	E-W output current (peak value)	TDA8375A, TDA8377A, TDA8375 and TDA8377	-	1.2	-	mA

ORDERING INFORMATION

TYPE NUMBER	PACKAGE		
	NAME	DESCRIPTION	VERSION
TDA837xA	SDIP56	plastic shrink dual in-line package; 56 leads (600 mil)	SOT400-1
TDA837xH	QFP64	plastic quad flat package; 64 leads (lead length 1.95 mm); body 14 × 20 × 2.7 mm; high stand-off height	SOT319-1

I²C-bus controlled economy PAL/NTSC and NTSC TV-processors

TDA837x family

BLOCK DIAGRAM

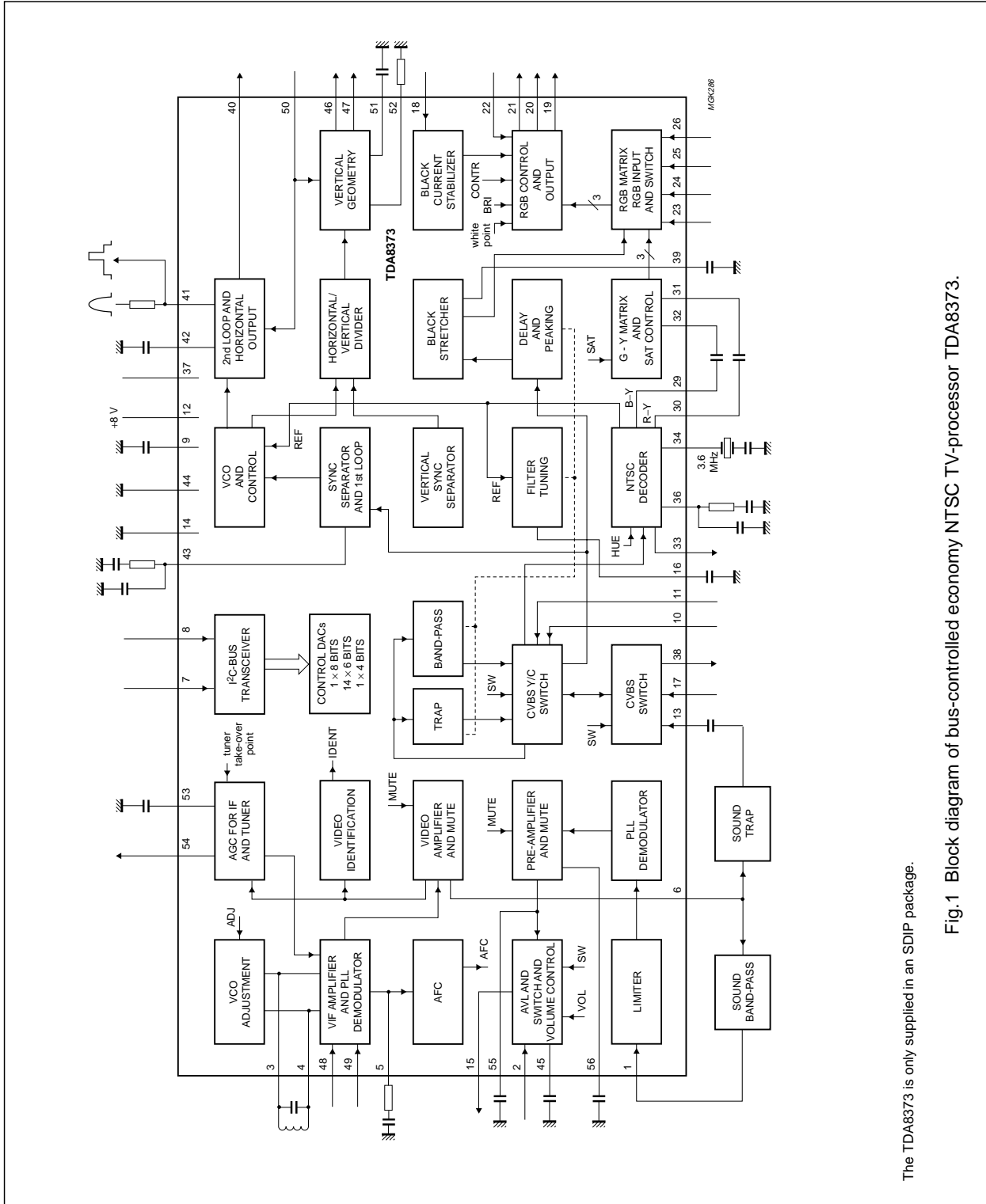

The TDA8373 is only supplied in an SDIP package.

Fig.1 Block diagram of bus-controlled economy NTSC TV-processor TDA8373.

I²C-bus controlled economy PAL/NTSC and NTSC TV-processors

TDA837x family

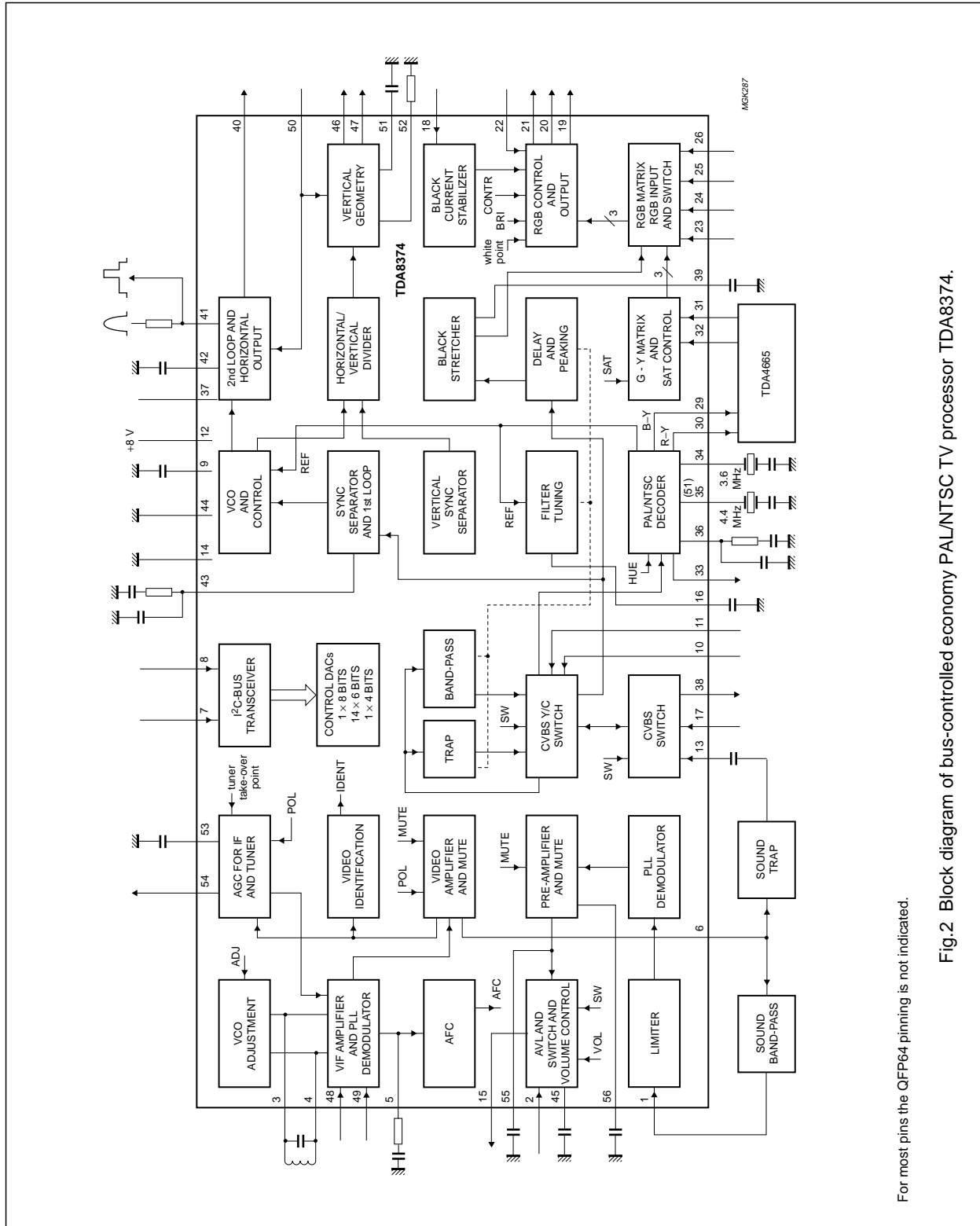

For most pins the QFP64 pinning is not indicated. **Fig.2** Block diagram of bus-controlled economy PAL/NTSC TV processor TDA8374.

I²C-bus controlled economy PAL/NTSC and NTSC TV-processors

TDA837x family

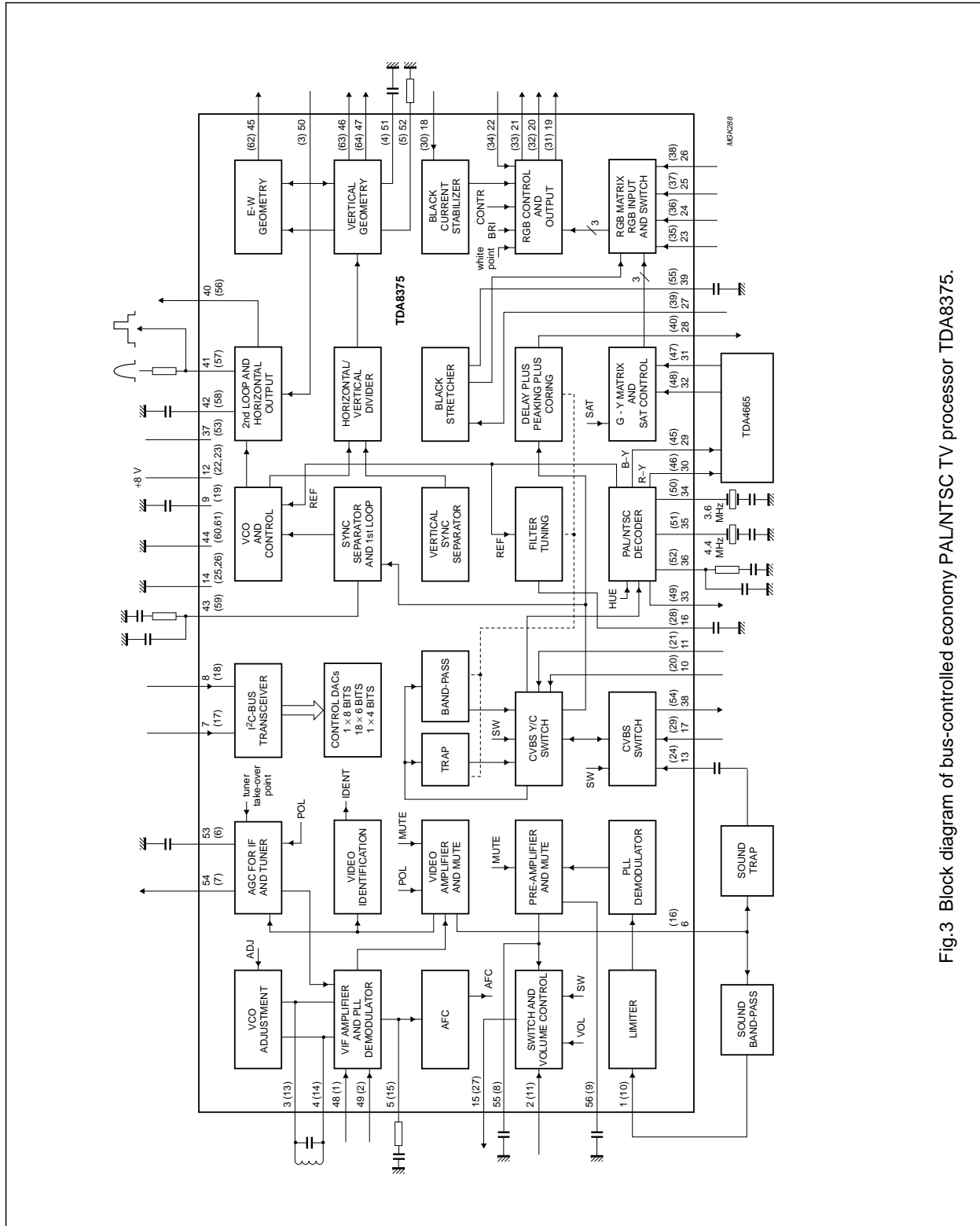
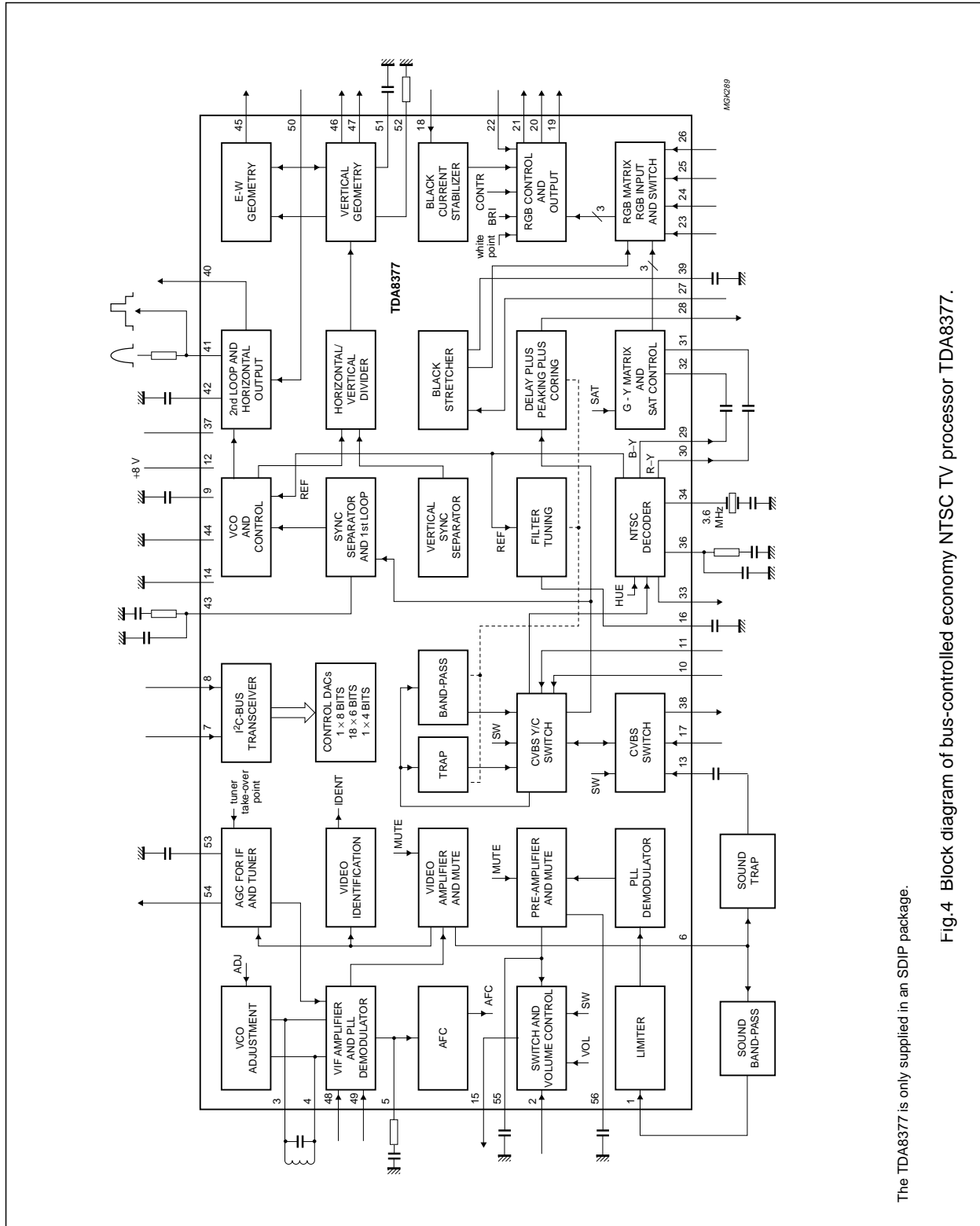

Fig.3 Block diagram of bus-controlled economy PAL/NTSC TV processor TDA8375.

I²C-bus controlled economy PAL/NTSC and NTSC TV-processors

TDA837x family



The TDA8377 is only supplied in an SDIP package.

Fig.4 Block diagram of bus-controlled economy NTSC TV processor TDA8377.

I²C-bus controlled economy PAL/NTSC and NTSC TV-processors

TDA837x family

PINNING

SYMBOL	PIN		DESCRIPTION
	SDIP56	QFP64	
SIF	1	10	sound IF input
AUDI	2	11	external audio input
VCO1	3	13	IF VCO 1 tuned circuit
VCO2	4	14	IF VCO 2 tuned circuit
PLL	5	15	PLL loop filter
IFVO	6	16	IF video output
SCL	7	17	serial clock input (I ² C-bus)
SDA	8	18	serial data input/output (I ² C-bus)
DEC _{BG}	9	19	band gap decoupling
CHROMA	10	20	chrominance input
CVBS/Y	11	21	CVBS/Y input
V _{P1}	12	22 and 23	main supply voltage (+8 V)
CVBS _{int}	13	24	internal CVBS input
GND1	14	25 and 26	ground
AUDO	15	27	audio output
DEC _{FT}	16	28	decoupling filter tuning
CVBS _{ext}	17	29	external CVBS input
BLKIN	18	30	black current input
BO	19	31	blue output
GO	20	32	green output
RO	21	33	red output
BCLIN	22	34	beam current input
RI	23	35	red input
GI	24	36	green input
BI	25	37	blue input
RGBIN	26	38	RGB insertion input
YIN	27 ⁽²⁾	39	luminance input
YOUT	28	40	luminance output
BYO	29	45	(B – Y) output
RYO	30	46	(R – Y) output
RYI	31	47	(R – Y) input
BYI	32	48	(B – Y) input
SEC _{ref}	33 ⁽¹⁾	49	SECAM reference output
XTAL1	34	50	3.58 MHz crystal connection
XTAL2	35 ⁽¹⁾	51	4.43 MHz crystal connection
LFBP	36	52	loop filter burst phase detector
V _{P2}	37	53	horizontal oscillator supply voltage (+8 V)
CVBSO	38	54	CVBS output

I²C-bus controlled economy PAL/NTSC and NTSC TV-processors

TDA837x family

SYMBOL	PIN		DESCRIPTION
	SDIP56	QFP64	
BLPH	39	55	black peak hold capacitor
HOUT	40	56	horizontal drive output
FBI/SCO	41	57	flyback input and sandcastle output
PH2	42	58	phase 2 filter/protection
PH1	43	59	phase 1 filter
GND2	44	60 and 61	ground 2
EWD	45 ⁽²⁾	62	east-west drive output
VDOB	46	63	vertical drive output B
VDOA	47	64	vertical drive output A
IFIN1	48	1	IF input 1
IFIN2	49	2	IF input 2
EHT/PRO	50	3	EHT/overvoltage protection input
VSAW	51	4	vertical sawtooth capacitor
I _{ref}	52	5	reference current input
DEC _{AGC}	53	6	AGC decoupling capacitor
AGCOUT	54	7	tuner AGC output
AUDEEM	55	8	audio deemphasis
DEC	56	9	decoupling sound demodulator
i.c.	–	12	internally connected
i.c.	–	41	internally connected
i.c.	–	42	internally connected
i.c.	–	43	internally connected
i.c.	–	44	internally connected

Notes

1. In the TDA8373 and TDA8377 pin 35 (4.43 MHz crystal) is internally connected and pin 33 is just a subcarrier output which can be used as a reference signal for comb filter ICs.
2. In the TDA8373 and TDA8374 the following pins are different (SDIP56): Pin 27: not connected; Pin 45: AVL capacitor.

I²C-bus controlled economy PAL/NTSC
and NTSC TV-processors

TDA837x family

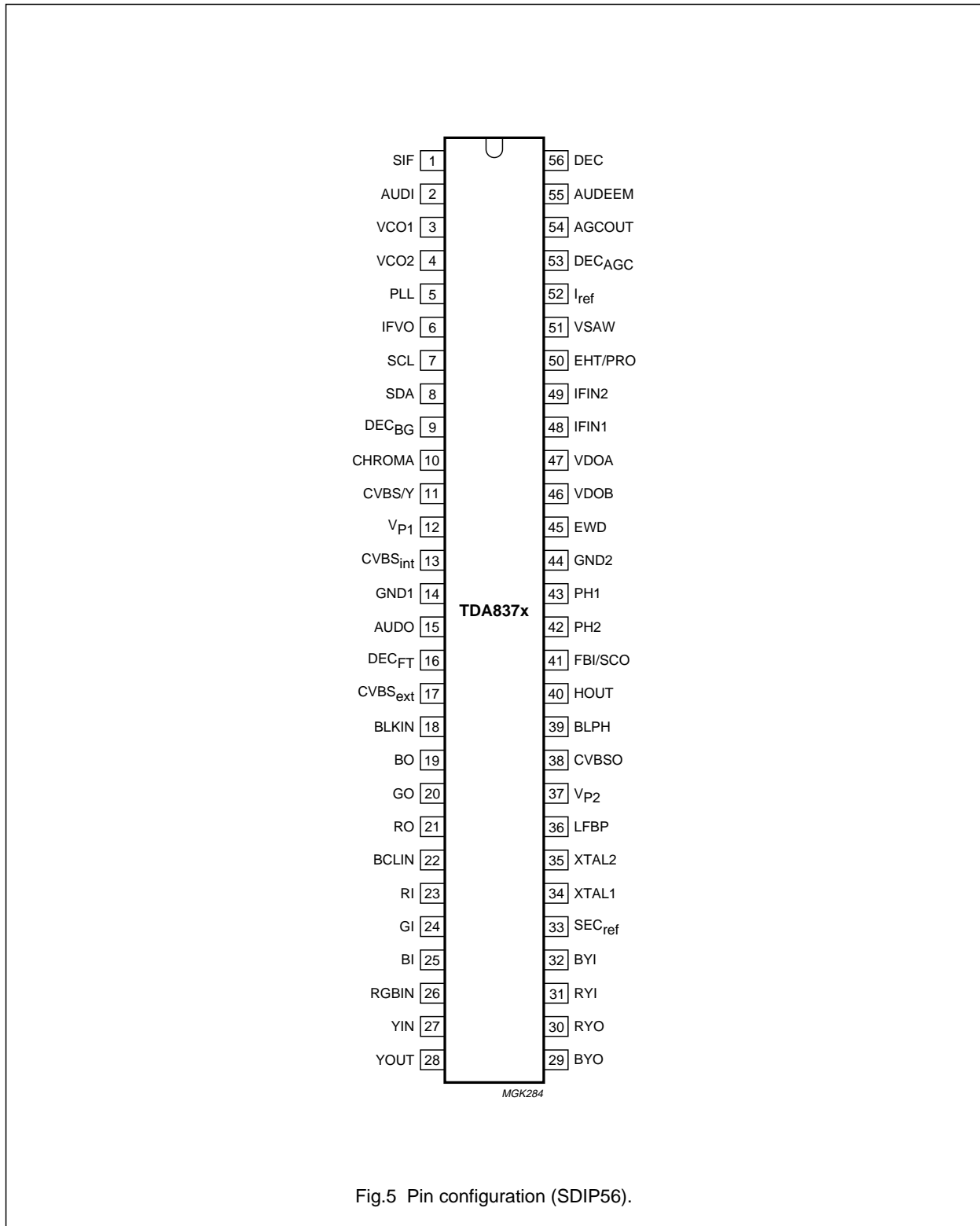

Fig.5 Pin configuration (SDIP56).

I²C-bus controlled economy PAL/NTSC
and NTSC TV-processors

TDA837x family

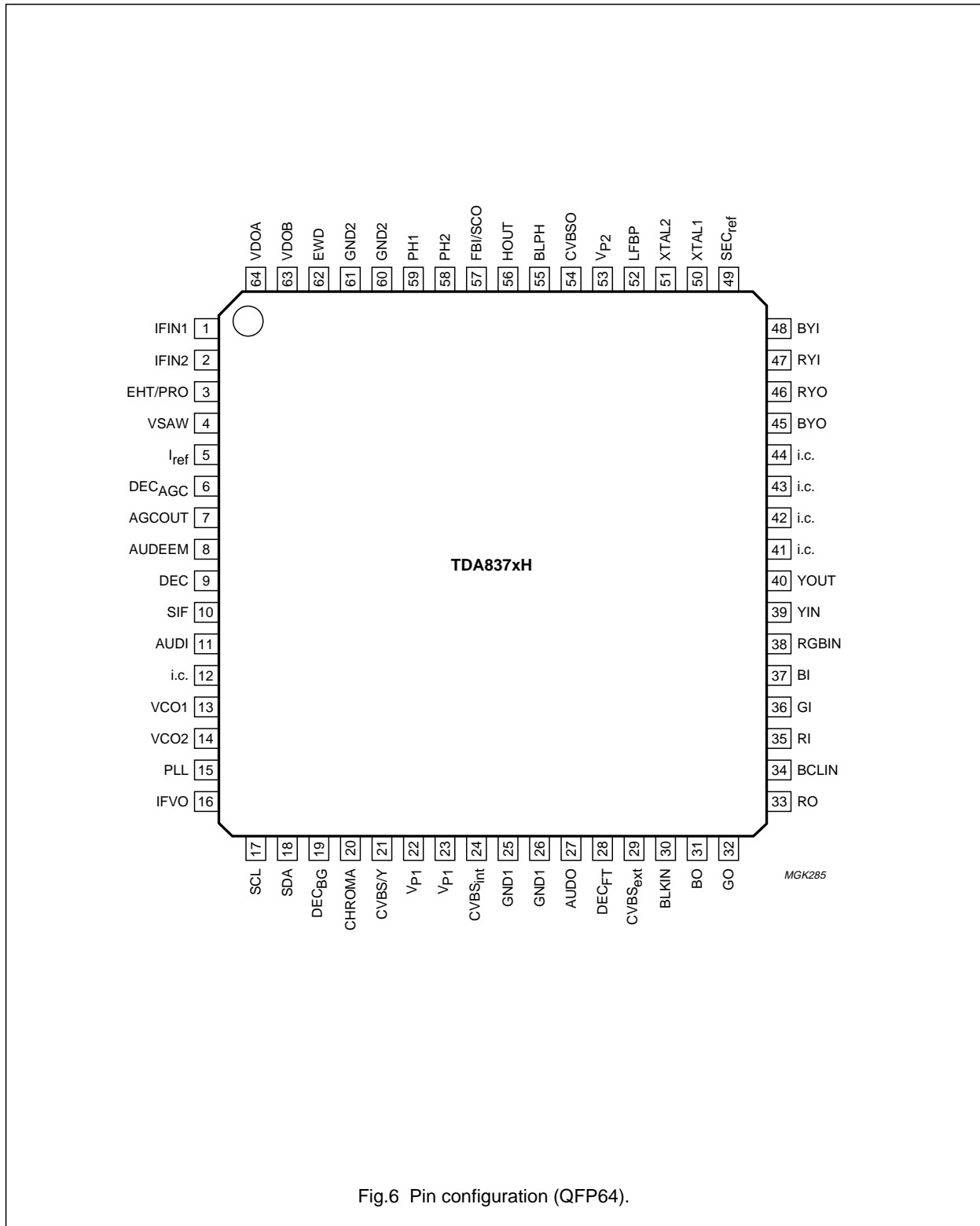

Fig.6 Pin configuration (QFP64).

I²C-bus controlled economy PAL/NTSC and NTSC TV-processors

TDA837x family

FUNCTIONAL DESCRIPTION

Vision IF amplifier

The IF amplifier contains 3 AC-coupled control stages with a total gain control range which is higher than 66 dB. The sensitivity of the circuit is comparable with that of modern IF-ICs.

The video signal is demodulated by a PLL carrier regenerator. This circuit contains a frequency detector and a phase detector. During acquisition the frequency detector will tune the VCO to the correct frequency. The initial adjustment of the oscillator is realized via the I²C-bus.

The switching, between SECAM L and L', can also be realized via the I²C-bus. After lock-in the phase detector controls the VCO so that a stable phase relationship between the VCO and the input signal is achieved. The VCO operates at twice the IF frequency. The reference signal for the demodulator is obtained by using a frequency divider circuit.

The AFC output is obtained by using the VCO control voltage of the PLL and can be read via the I²C-bus. For fast search tuning systems the window of the AFC can be increased by a factor of 3. The setting is realized with the AFW bit.

Depending on the device type the AGC detector operates on top-sync level (single standard versions) or on top-sync and top-white level (multistandard versions). The demodulation polarity is switched via the I²C-bus. The AGC detector time constant capacitor is connected externally. This is mainly because of the flexibility of the application. The time constant of the AGC system during positive modulation is rather long, this is to avoid visible variations of the signal amplitude. To improve the speed of the AGC system, a circuit has been included which detects whether the AGC detector is activated every frame period. When, during 3 frame periods, no action is detected the speed of the system is increased. For signals without peak-white information the system switches automatically

to a gated black level AGC. Because a black level clamp pulse is required for this method of operation the circuit will only switch to black level AGC in the internal mode.

The circuits contain a second fast video identification circuit which is independent of the synchronization identification circuit. Consequently, search tuning is also possible when the display section of the receiver is used as a monitor. However, this identification circuit cannot be made as sensitive as the slower sync identification circuit (SL) and it is recommended to use both identification outputs to obtain a reliable search system.

The identification output is applied to the tuning system via the I²C-bus.

The input of the identification circuit is connected to pin 13, the internal CVBS input (see Fig.1). This has the advantage that the identification circuit can also be made operative when a scrambled signal is received [descrambler connected between the IF video output (pin 6) and pin 13]. A second advantage is that the identification circuit can be used when the IF amplifier is not used (e.g. with built-in satellite tuners).

The video identification circuit can also be used to identify the selected CBVS or Y/C signal. The switching between the two modes can be realized with bit VIM.

Video switches

The circuit has two CVBS inputs (CVBS_{int} and CVBS_{ext}) and a Y/C input. When the Y/C input is not required pin 11 can be used as the third CVBS input. The switch configuration is illustrated in Fig.7. The selection of the various sources is made via the I²C-bus.

The output signal of the CVBS switch is externally available and can be used to drive the teletext decoder, the SECAM add-on decoder and a comb filter.

In applications with comb filters a Y/C input is only possible when additional switches are added. In applications without comb filters the Y/C input signal can be switched to the CVBS output.

I²C-bus controlled economy PAL/NTSC and NTSC TV-processors

TDA837x family

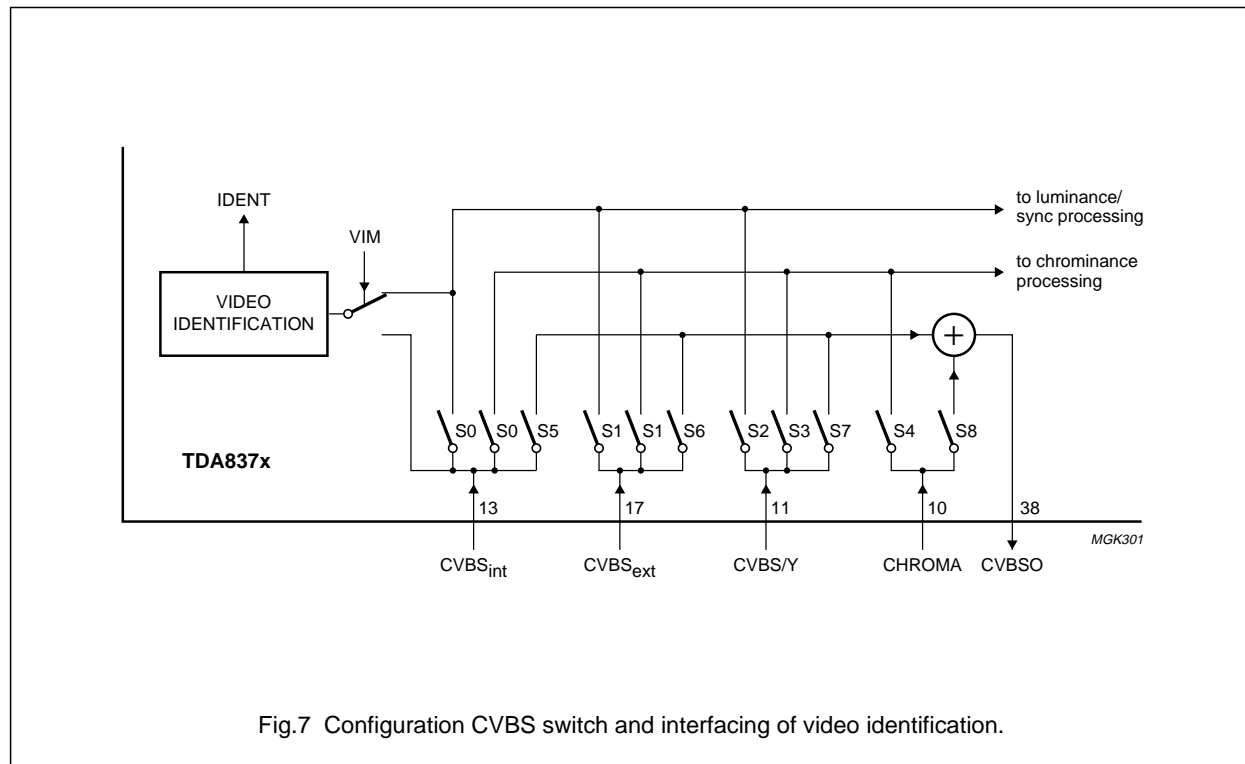

Fig.7 Configuration CVBS switch and interfacing of video identification.

Sound circuit

The sound band-pass and trap filters have to be connected externally. The filtered intercarrier signal is fed to a limiter circuit and is demodulated by a PLL demodulator. This PLL circuit automatically tunes to the incoming carrier signal, hence no adjustment is required.

The volume is controlled via the I²C-bus. The de-emphasis capacitor has to be connected externally.

The non-controlled audio signal can be obtained from this pin (pin 55) (via a buffer stage).

The FM demodulator can be muted via the I²C-bus. This function can be used to switch-off the sound during a channel change so that high output peaks are prevented (also on the de-emphasis output).

The TDA8373 and TDA8374 contain an Automatic Volume Levelling (AVL) circuit which automatically stabilizes the audio output signal to a certain level which can be set by the user via the volume control. This function prevents big audio output fluctuations due to variations of the modulation depth of the transmitter. The AVL function can be activated via the I²C-bus.

Synchronization circuit

The sync separator is preceded by a controlled amplifier which adjusts the sync pulse amplitude to a fixed level. These pulses are fed to the slicing stage which operates at 50% of the amplitude.

The separated sync pulses are fed to the first phase detector and to the coincidence detector. The coincidence detector is used to detect whether the line oscillator is synchronized and can also be used for transmitter identification. The circuit can be made less sensitive by using the STM bit. This mode can be used during search tuning to ensure that the tuning system will not stop at very weak input signals. The first PLL has a very high static steepness so that the phase of the picture is independent of the line frequency.

The line oscillator operates at twice the line frequency. The oscillator capacitor is internal. Because of the spread of internal components an automatic calibration circuit has been added to the IC. The circuit compares the oscillator frequency with that of the crystal oscillator in the colour decoder.

I²C-bus controlled economy PAL/NTSC and NTSC TV-processors

TDA837x family

This results in a free-running frequency which deviates less than 2% from the typical value. When the IC is switched on the horizontal output signal is suppressed and the oscillator is calibrated as soon as all subaddress bytes have been sent. When the frequency of the oscillator is correct the horizontal drive signal is switched on. To obtain a smooth switching on and switching off behaviour of the horizontal output stage the horizontal output frequency is doubled during switch-on and switch-off (slow start/stop). During that time the duty cycle of the output pulse has such a value that maximum safety is obtained for the output stage.

To protect the horizontal output transistor, the horizontal drive is immediately switched off (via the slow stop procedure) when a power-on reset is detected. The drive signal is switched on again when the normal switch-on procedure is followed, i.e. all subaddress bytes must be sent and, after calibration, the horizontal drive signal will be released again via the slow start procedure.

When the coincidence detector indicates an out-of-lock situation the calibration procedure is repeated.

The circuit has a second control loop to generate the drive pulses for the horizontal driver stage. The horizontal output is gated with the flyback pulse so that the horizontal output transistor cannot be switched on during the flyback time.

Adjustments can be made to the horizontal shift, vertical shift, vertical slope, vertical amplitude and the S-correction via the I²C-bus. In the TDA8375A, TDA8377A, TDA8375 and TDA8377 the E-W drive can also be adjusted via the I²C-bus. The TDA8375 and TDA8377 have a flexible zoom adjustment possibility for the vertical and horizontal deflection. When the horizontal scan is reduced to display 4 : 3 pictures on a 16 : 9 picture tube an accurate video blanking can be switched on to obtain well defined edges on the screen. The geometry processor has a differential output for the vertical drive signal and a single-ended output for the E-W drive (TDA8375A, TDA8377A, TDA8375 and TDA8377). Overvoltage conditions (X-ray protection) can be detected via the EHT tracking pin. When an overvoltage condition is detected the horizontal output drive signal will be switched off via the slow stop procedure. However, it is also possible that the drive is not switched off and that just a protection indication is given in the I²C-bus output byte. The choice is made via the input bit PRD. The ICs have a second protection input on the phase-2 filter capacitor pin. When this input is activated the drive signal is switched off immediately (without slow stop) and switched on again via the slow start procedure.

For this reason this protection input can be used as 'flash protection'.

The drive pulses for the vertical sawtooth generator are obtained from a vertical countdown circuit. This countdown circuit has various windows depending on the incoming signal (50 or 60 Hz and standard or non-standard). The countdown circuit can be forced in various modes via the I²C-bus. To obtain short switching times of the countdown circuit during a channel change the divider can be forced in the search window using the NCIN bit.

The vertical deflection can be set in the de-interlace mode via the I²C-bus.

To avoid damage of the picture tube when the vertical deflection fails, the guard output current of the TDA8350 and TDA8351 can be supplied to the beam current limiting input. When a failure is detected the RGB outputs are blanked and a bit is set (NDF) in the status byte of the I²C-bus. When no vertical deflection output stage is connected this guard circuit will also blank the output signals. This can be overruled using the EVG bit.

Chrominance and luminance processing

The circuit contains a chrominance band-pass and trap circuit. The filters are realized by using gyrator circuits. They are automatically calibrated by comparing the tuning frequency with the crystal frequency of the decoder. The luminance delay line and the delay for the peaking circuit are also realized by using gyrator circuits. The centre frequency of the chrominance band-pass filter is 10% higher than the subcarrier frequency. This compensates for the high frequency attenuation of the IF saw filter. During SECAM reception the centre frequency of the chrominance trap is reduced to obtain a better suppression of the SECAM carrier frequencies. All ICs have a black stretcher circuit which corrects the black level for incoming video signals which have a deviation between the black level and the blanking level (back porch).

The TDA8375A, TDA8377A, TDA8375 and TDA8377 have a defeatable coring function in the peaking circuit.

Some of the ICs have a YUV interface so that picture improvement ICs such as the TDA9170 (contrast improvement), TDA9177 (sharpness improvement) and TDA4556 and TDA4566 (CTI) can be applied. When the TDA4556 or TDA4566 is applied it is possible to increase the gain of the luminance channel by using the GAI bit in subaddress 03 so that the resulting RGB output signals will not be affected.

I²C-bus controlled economy PAL/NTSC and NTSC TV-processors

TDA837x family

Colour decoder

Depending on the IC type the colour decoder can decode NTSC signals (TDA8373 and TDA8377) or PAL/NTSC signals (TDA8374 and TDA8375). The circuit contains an alignment-free crystal oscillator, a killer circuit and two colour difference demodulators. The 90° phase shift for the reference signal is made internally.

The TDA8373 and TDA8377 contain an Automatic Colour Limiting (ACL) circuit which prevents over saturation occurring when signals with a high chroma-to-burst ratio are received. This ACL function is also available in the TDA8374 and TDA8375, however, it is only active during the reception of NTSC signals.

The TDA8373 and TDA8377 have a switchable colour difference matrix (via the I²C-bus) so that the colour reproduction can be adapted to the market requirements.

In the TDA8374 and TDA8375 the colour difference matrix switches automatically between PAL and NTSC, however, it is also possible to fix the matrix in the PAL standard.

The TDA8374 and TDA8375 can operate in conjunction with the SECAM decoder TDA8395 so that an automatic multistandard decoder can be realized. The subcarrier reference output for the SECAM decoder can also be used as a reference signal for a comb filter. Consequently, the reference signal is continuously available when PAL or NTSC signals are detected and only present during the vertical retrace period when a SECAM signal is detected.

Which standard the TDA8374 and TDA8375 can decode depends on the external crystals. The crystal to be connected to pin 34 must have a frequency of 3.5 MHz (NTSC-M, PAL-M or PAL-N). Pin 35 can handle crystals with a frequency of 4.4 and 3.5 MHz. Because the crystal frequency is used to tune the line oscillator, the value of the crystal frequency must be communicated to the IC via the I²C-bus. It is also possible to use the IC in the so called '3-norma' mode for South America. In that event one crystal must be connected to pin 35 and the other two to pin 34. Switching between the 2 latter crystals must be performed externally. Consequently, the search loop of the decoder must be controlled by the microcontroller.

To prevent calibration problems of the horizontal oscillator the external switching between the two crystals should be performed when the oscillator is forced to pin 35.

For a reliable calibration of the horizontal oscillator it is very important that the crystal indication bits (XA and XB) are not corrupted. For this reason the crystal bits can be read in the output bytes so that the software can check the I²C-bus transmission.

RGB output circuit and black current stabilization

The colour difference signals are matrixed with the luminance signal to obtain the RGB signals. Linear amplifiers have been chosen for the RGB inputs so that the circuit is suited for signals that are input from the SCART connector. The insertion blanking can be switched on or off using the IE1 bit. To ascertain whether the insertion pin has a (continuous) HIGH level or not can be read via the IN1 bit. The contrast and brightness control operate on internal and external signals.

The output signal has an amplitude of approximately 2 V (black-to-white) at nominal input signals and nominal settings of the controls. To increase the flexibility of the IC it is possible to add OSD and/or teletext signals directly at the RGB outputs. This insertion mode is controlled via the insertion input. The action to switch the RGB outputs to black has some delay which must be compensated for externally.

The black current stabilization is realized by using a feedback from the video output amplifiers to the RGB control circuit. The black current of the 3 guns of the picture tube is internally measured and stabilized.

The black level control is active during 4 lines at the end of the vertical blanking. The vertical blanking is adapted to the incoming CVBS signal (50 or 60 Hz). When the flyback time of the vertical output stage is longer than the 60 Hz blanking time, or when additional lines need to be blanked (e.g. for close captioning lines) the blanking can be increased to the same value as that of the 50 Hz blanking. This can be set using the LBM bit. The leakage current is measured during the first line and, during the following 3 lines, the 3 guns are adjusted to the required level.

The maximum acceptable leakage current is $\pm 100 \mu\text{A}$. The nominal value of the black current is $10 \mu\text{A}$. The ratio of the currents for the various guns automatically tracks with the white point adjustment so that the background colour is the same as the adjusted white point.

I²C-bus controlled economy PAL/NTSC and NTSC TV-processors

TDA837x family

The input impedance of the black current measuring pin is 14 k Ω . To prevent the voltage on this pin exceeding the supply voltage during scan an internal protection diode has been included.

When the TV receiver is switched on the black current stabilization circuit is not active, the RGB outputs are blanked and the beam current limiting input pin is short-circuited. Only during the measuring lines will the outputs supply a voltage of 4.2 V to the video output stage

to ascertain whether the picture tube is warming up. As soon as the current supplied to the measuring input exceeds a value of 190 μ A the stabilization circuit will be activated. After a waiting time of approximately 0.8 s the blanking and beam current limiting input pins are released. The remaining switch-on behaviour of the picture is determined by the external time constant of the beam current limiting network.

I²C-bus specification

Table 3 Slave address (8A)

A6	A5	A4	A3	A2	A1	A0	R/W
1	0	0	0	1	0	1	I/O

The slave address is identical for all types. The subaddresses of the various types are slightly different. The list of subaddresses for each type is given in Tables 4, 6, 8 and 10.

START-UP PROCEDURE

Read the status bytes until POR = 0 and send all subaddress bytes. The horizontal output signal is switched

on when the oscillator is calibrated. Each time before the data in the IC is refreshed, the status bytes must be read. If POR = 1, then the procedure given above must be carried out to restart the IC. When this procedure is not followed the horizontal frequency in the TDA8374 and TDA8375 may be incorrect after power-up or a power dip.

I²C-bus controlled economy PAL/NTSC and NTSC TV-processors

TDA837x family

TDA8373

Valid subaddresses: 00 to 16 (subaddresses 04 to 07 are not used), subaddress FE is reserved for test purposes.
Auto-increment mode available for subaddresses.

Table 4 Inputs

FUNCTION	SUB ADDRESS	DATA BYTE							
		D7	D6	D5	D4	D3	D2	D1	D0
Control 0	00	INA	INB	INC	0	FOA	FOB	0	0
Control 1	01	0	0	DL	STB	POC	0	1	1
Hue	02	AVL	AKB	A5	A4	A3	A2	A1	A0
Horizontal Shift (HS)	03	VIM	GAI	A5	A4	A3	A2	A1	A0
Vertical Slope (VS)	08	NCIN	STM	A5	A4	A3	A2	A1	A0
Vertical Amplitude (VA)	09	VID	LBM	A5	A4	A3	A2	A1	A0
S-Correction (SC)	0A	0	EVG	A5	A4	A3	A2	A1	A0
Vertical shift (VSH)	0B	SBL	PRD	A5	A4	A3	A2	A1	A0
White point R	0C	0	0	A5	A4	A3	A2	A1	A0
White point G	0D	0	0	A5	A4	A3	A2	A1	A0
White point B	0E	MAT	0	A5	A4	A3	A2	A1	A0
Peaking	0F	0	0	0	0	A3	A2	A1	A0
Brightness	10	RBL	0	A5	A4	A3	A2	A1	A0
Saturation	11	IE1	0	A5	A4	A3	A2	A1	A0
Contrast	12	AFW	IFS	A5	A4	A3	A2	A1	A0
AGC takeover	13	0	VSW	A5	A4	A3	A2	A1	A0
Volume control	14	SM	FAV	A5	A4	A3	A2	A1	A0
Adjustment IF-PLL	15	L'FA	A6	A5	A4	A3	A2	A1	A0
Spare	16	0	0	0	0	0	0	0	0

Table 5 Output status bytes (note 1)

OUTPUT ADDRESS	D7	D6	D5	D4	D3	D2	D1	D0
00	POR	X	X	SL	XPR	CD2	CD1	CD0
01	NDF	IN1	X	IFI	AFA	AFB	SXA	SXB
02	X	X	X	IVW	X	ID2	ID1	ID0

Note

1. X = don't care.

I²C-bus controlled economy PAL/NTSC and NTSC TV-processors

TDA837x family

TDA8374, TDA8374AH and TDA8374BH

Valid subaddresses: 00 to 16 (subaddresses 04 to 07 are not used), subaddress FE is reserved for test purposes.
Auto-increment mode available for subaddresses.

Table 6 Inputs (notes 1 and 2)

FUNCTION	SUB ADDRESS	DATA BYTE							
		D7	D6	D5	D4	D3	D2	D1	D0
Control 0	00	INA	INB	INC	0	FOA	FOB	XA	XB
Control 1	01	FORF	FORS	DL	STB	POC	CM2	CM1	CM0
Hue	02	AVL	AKB	A5	A4	A3	A2	A1	A0
Horizontal Shift (HS)	03	VIM	GAI	A5	A4	A3	A2	A1	A0
Vertical Slope (VS)	08	NCIN	STM	A5	A4	A3	A2	A1	A0
Vertical Amplitude (VA)	09	VID	LBM	A5	A4	A3	A2	A1	A0
S-Correction (SC)	0A	0	EVG	A5	A4	A3	A2	A1	A0
Vertical shift (VSH)	0B	SBL	PRD	A5	A4	A3	A2	A1	A0
White point R	0C	0	0	A5	A4	A3	A2	A1	A0
White point G	0D	0	0	A5	A4	A3	A2	A1	A0
White point B	0E	MAT	0	A5	A4	A3	A2	A1	A0
Peaking	0F	0	0	0	0	A3	A2	A1	A0
Brightness	10	RBL	0	A5	A4	A3	A2	A1	A0
Saturation	11	IE1	0	A5	A4	A3	A2	A1	A0
Contrast	12	AFW	IFS	A5	A4	A3	A2	A1	A0
AGC takeover	13	MOD	VSW	A5	A4	A3	A2	A1	A0
Volume control	14	SM	FAV	A5	A4	A3	A2	A1	A0
Adjustment IF-PLL	15	L'FA	A6	A5	A4	A3	A2	A1	A0
Spare	16	0	0	0	0	0	0	0	0

Notes

1. The AVL and MOD bit are not available in the TDA8374A.
2. In the TDA8374B the AVL and MOD bit is also missing and the CM0 to CM2 and CD0 to CD2 bits have less possibilities because this IC can only decode PAL or PAL/SECAM signals (when the TDA8395 is applied).

Table 7 Output status bytes (note 1)

OUTPUT ADDRESS	D7	D6	D5	D4	D3	D2	D1	D0
00	POR	FSI	X	SL	XPR	CD2	CD1	CD0
01	NDF	IN1	X	IFI	AFA	AFB	SXA	SXB
02	X	X	X	IVW	X	ID2	ID1	ID0

Note

1. X = don't care.

I²C-bus controlled economy PAL/NTSC and NTSC TV-processors

TDA837x family

TDA8375 and TDA8375AH

Valid subaddresses: 00 to 16, subaddress FE is reserved for test purposes. Auto-increment mode available for subaddresses.

Table 8 Inputs

FUNCTION	SUB ADDRESS	DATA BYTE							
		D7	D6	D5	D4	D3	D2	D1	D0
Control 0	00	INA	INB	INC	0	FOA	FOB	XA	XB
Control 1	01	FORF	FORS	DL	STB	POC	CM2	CM1	CM0
Hue	02	HBL	AKB	A5	A4	A3	A2	A1	A0
Horizontal Shift (HS)	03	VIM	GAI	A5	A4	A3	A2	A1	A0
E-W width (EW)	04	0	0	A5	A4	A3	A2	A1	A0
E-W Parabola/Width (PW)	05	0	0	A5	A4	A3	A2	A1	A0
E-W Corner Parabola (CP)	06	0	0	A5	A4	A3	A2	A1	A0
E-W trapezium (TC)	07	0	0	A5	A4	A3	A2	A1	A0
Vertical Slope (VS)	08	NCIN	STM	A5	A4	A3	A2	A1	A0
Vertical Amplitude (VA)	09	VID	LBM	A5	A4	A3	A2	A1	A0
S-Correction (SC)	0A	HCO	EVG	A5	A4	A3	A2	A1	A0
Vertical shift (VSH)	0B	SBL	PRD	A5	A4	A3	A2	A1	A0
White point R	0C	0	0	A5	A4	A3	A2	A1	A0
White point G	0D	0	0	A5	A4	A3	A2	A1	A0
White point B	0E	MAT	0	A5	A4	A3	A2	A1	A0
Peaking	0F	0	0	0	0	A3	A2	A1	A0
Brightness	10	RBL	COR	A5	A4	A3	A2	A1	A0
Saturation	11	IE1	0	A5	A4	A3	A2	A1	A0
Contrast	12	AFW	IFS	A5	A4	A3	A2	A1	A0
AGC takeover	13	MOD	VSW	A5	A4	A3	A2	A1	A0
Volume control	14	SM	FAV	A5	A4	A3	A2	A1	A0
Adjustment IF-PLL	15	L'FA	A6	A5	A4	A3	A2	A1	A0
Vertical zoom (VX) ⁽¹⁾	16	0	0	A5	A4	A3	A2	A1	A0

Note

1. The vertical zoom byte and the HBL bit are active only in the TDA8375.

Table 9 Output status bytes (note 1)

OUTPUT ADDRESS	D7	D6	D5	D4	D3	D2	D1	D0
00	POR	FSI	X	SL	XPR	CD2	CD1	CD0
01	NDF	IN1	X	IFI	AFA	AFB	SXA	SXB
02	X	X	X	IVW	X	ID2	ID1	ID0

Note

1. X = don't care.

I²C-bus controlled economy PAL/NTSC and NTSC TV-processors

TDA837x family

TDA8377 and TDA8377A

Valid subaddresses: 00 to 16, subaddress FE is reserved for test purposes. Auto-increment mode available for subaddresses.

Table 10 Inputs

FUNCTION	SUB ADDRESS	DATA BYTE							
		D7	D6	D5	D4	D3	D2	D1	D0
Control 0	00	INA	INB	INC	0	FOA	FOB	0	1
Control 1	01	0	0	DL	STB	POC	0	1	1
Hue	02	HBL	AKB	A5	A4	A3	A2	A1	A0
Horizontal Shift (HS)	03	VIM	GAI	A5	A4	A3	A2	A1	A0
E-W width (EW)	04	0	0	A5	A4	A3	A2	A1	A0
E-W Parabola/Width (PW)	05	0	0	A5	A4	A3	A2	A1	A0
E-W Corner Parabola (CP)	06	0	0	A5	A4	A3	A2	A1	A0
E-W trapezium (TC)	07	0	0	A5	A4	A3	A2	A1	A0
Vertical Slope (VS)	08	NCIN	STM	A5	A4	A3	A2	A1	A0
Vertical Amplitude (VA)	09	VID	0	A5	A4	A3	A2	A1	A0
S-Correction (SC)	0A	HCO	EVG	A5	A4	A3	A2	A1	A0
Vertical shift (VSH)	0B	SBL	PRD	A5	A4	A3	A2	A1	A0
White point R	0C	0	0	A5	A4	A3	A2	A1	A0
White point G	0D	0	0	A5	A4	A3	A2	A1	A0
White point B	0E	MAT	0	A5	A4	A3	A2	A1	A0
Peaking	0F	0	0	0	0	A3	A2	A1	A0
Brightness	10	RBL	COR	A5	A4	A3	A2	A1	A0
Saturation	11	IE1	0	A5	A4	A3	A2	A1	A0
Contrast	12	AFW	IFS	A5	A4	A3	A2	A1	A0
AGC takeover	13	0	VSW	A5	A4	A3	A2	A1	A0
Volume control	14	SM	FAV	A5	A4	A3	A2	A1	A0
Adjustment IF-PLL	15	L'FA	A6	A5	A4	A3	A2	A1	A0
Vertical zoom (VX) ⁽¹⁾	16	0	0	A5	A4	A3	A2	A1	A0

Note

1. The vertical zoom byte and the HBL bit are active only in the TDA8377.

Table 11 Output status bytes (note 1)

OUTPUT ADDRESS	D7	D6	D5	D4	D3	D2	D1	D0
00	POR	X	X	SL	XPR	CD2	CD1	CD0
01	NDF	IN1	X	IFI	AFA	AFB	SXA	SXB
02	X	X	X	IVW	X	ID2	ID1	ID0

Note

1. X = don't care.

I²C-bus controlled economy PAL/NTSC and NTSC TV-processors

TDA837x family

INPUT CONTROL BITS

Table 12 Source select

INA	INB	INC	SELECTED SIGNALS (DECODER AND AUDIO)	SWITCH OUTPUT
0	0	0	internal CVBS plus audio	internal CVBS
0	0	1	external CVBS plus audio	external CVBS
0	1	0	Y/C plus external audio	Y/C (Y plus C)
0	1	1	CVBS3 plus external audio	CVBS3
1	0	0	Y/C plus internal audio	internal CVBS
1	1	0	Y/C plus external audio	external CVBS

Table 13 Phase 1 ($\phi-1$) time constant

FOA	FOB	MODE
0	0	normal
0	1	slow and gated
1	0	slow/fast and gated
1	1	fast

Table 14 Crystal indication

XA	XB	CRYSTAL
0	0	two 3.6 MHz crystals
0	1	one 3.6 MHz crystal (pin 34)
1	0	one 4.4 MHz crystal (pin 35)
1	1	3.6 MHz and 4.4 MHz crystals (pins 34 and 35)

Table 15 Forced field frequency TDA8374 and TDA8375

FORF	FORS	FIELD FREQUENCY
0	0	auto (60 Hz when line not synchronized)
0	1	60 Hz; note 1
1	0	keep last detected field frequency
1	1	auto (50 Hz when line not synchronized)

Note

1. When switched to this mode while locked to a 50 Hz signal, the divider will only switch to forced 60 Hz when an out-of-sync is detected in the horizontal PLL.

I²C-bus controlled economy PAL/NTSC and NTSC TV-processors

TDA837x family

Table 16 Interlace

DL	STATUS
0	interlace
1	de-interlace

Table 17 Standby

STB	MODE
0	standby
1	normal

Table 18 Synchronization mode

POC	MODE
0	synchronization active
1	synchronization not active

Table 19 Colour decoder mode

CM2	CM1	CM0	DECODER MODE
0	0	0	not forced, own intelligence, two crystals
0	0	1	forced crystal pin 34 (PAL/NTSC)
0	1	0	forced crystal pin 34 (PAL)
0	1	1	forced crystal pin 34 (NTSC)
1	0	0	forced crystal pin 35 (PAL/NTSC)
1	0	1	forced crystal pin 35 (PAL)
1	1	0	forced crystal pin 35 (NTSC)
1	1	1	forced SECAM crystal pin 35

Table 20 Automatic volume levelling
(TDA8373 and TDA8374)

AVL	LEVEL
0	automatic volume levelling not active
1	automatic volume levelling active

Table 21 RGB blanking mode (TDA8375 and TDA8377)

HBL	MODE
0	normal blanking with horizontal blanking pulse
1	wider blanking to obtain well defined edges

Table 22 Black current stabilization

AKB	STABILIZATION
0	black-current stabilization on
1	black-current stabilization off

Table 23 Video identification mode

VIM	VIDEO IDENT MODE
0	video identification coupled to the internal CVBS input (pin 13)
1	video identification coupled to the selected CVBS input

Table 24 Gain of luminance channel

GAI	GAIN
0	normal gain of luminance channel [V ₂₇ = 1.0 V (b-w)]
1	high gain of luminance channel [V ₂₇ = 0.45 V (p-p)]

Table 25 Vertical divider mode

NCIN	VERTICAL DIVIDER MODE
0	normal operation of the vertical divider
1	vertical divider switched to search window

Table 26 Search tuning mode

STM	SEARCH TUNING MODE
0	normal operation
1	reduced sensitivity of the coincidence detector (bit SL)

Table 27 Video identification mode

VID	VIDEO IDENT MODE
0	video identification switches phase 1 loop on and off
1	video identification not active

Table 28 Long blanking mode (TDA8374 and TDA8375)

LBM	BLANKING MODE
0	blanking adapted to standard (50 or 60 Hz)
1	fixed blanking in accordance with 50 Hz standard

I²C-bus controlled economy PAL/NTSC and NTSC TV-processors

TDA837x family

Table 29 EHT tracking mode (TDA8375 and TDA8377)

HCO	TRACKING MODE
0	EHT tracking only on vertical
1	EHT tracking on vertical and E-W

Table 30 Enable vertical guard (RGB blanking)

EVG	VERTICAL GUARD MODE
0	vertical guard not active
1	vertical guard active

Table 31 Service blanking

SBL	SERVICE BLANKING MODE
0	service blanking off
1	service blanking on

Table 32 Overvoltage input mode

PRD	OVERVOLTAGE MODE
0	overvoltage detection mode
1	overvoltage protection mode

Table 33 PAL/NTSC or NTSC matrix
(TDA8374 and TDA8375)

MAT	MATRIX
0	matrix adapted to standard (NTSC = Japanese)
1	PAL matrix

Table 34 PAL/NTSC or NTSC matrix
(TDA8373 and TDA8377)

MAT	MATRIX
0	Japanese matrix
1	USA matrix

Table 35 RGB blanking

RBL	MODE
0	blanking not active
1	blanking active

Table 36 Noise coring peaking
(TDA8375 and TDA8377))

COR	MODE
0	noise coring off
1	noise coring on

Table 37 Enable fast blanking

IE1	FAST BLANKING
0	fast blanking not active
1	fast blanking active

Table 38 AFC window

AFW	AFC WINDOW
0	normal window
1	enlarged window

Table 39 IF sensitivity

IFS	IF SENSITIVITY
0	normal sensitivity
1	reduced sensitivity

Table 40 Modulation standard (TDA8374 and TDA8375)

MOD	MODULATION
0	negative modulation
1	positive modulation

Table 41 Video mute

VSW	STATE
0	normal operation
1	IF video signal switched off

Table 42 Sound mute

SM	STATE
0	normal operation
1	sound muted

I²C-bus controlled economy PAL/NTSC and NTSC TV-processors

TDA837x family

Table 43 Fixed audio volume

FAV	STATE
0	normal volume control
1	audio output level fixed

Table 44 Demodulator frequency adjustment

L'FA	STATE
0	normal IF frequency
1	frequency shift for L' standard

OUTPUT CONTROL BITS

Table 45 Power-on-reset

POR	MODE
0	normal mode
1	power-down mode

Table 46 Field frequency (TDA8374 and TDA8375)

FSI	FREQUENCY
0	50 Hz
1	60 Hz

Table 47 Phase 1 lock indication

SL	INDICATION
0	not locked
1	locked

Table 48 X-ray protection

XPR	OVERVOLTAGE
0	no overvoltage detected
1	overvoltage detected

Table 49 Colour decoder mode (TDA8374 and TDA8375)

CD2	CD1	CD0	STANDARD
0	0	0	no colour standard identified
0	0	1	NTSC with crystal at pin 34
0	1	0	PAL with crystal at pin 35
0	1	1	SECAM
1	0	0	NTSC with crystal at pin 35
1	0	1	PAL with crystal at pin 34
1	1	0	spare
1	1	1	spare

Table 50 Output vertical guard

NDF	VERTICAL OUTPUT STAGE
0	vertical output stage OK
1	failure in vertical output stage

Table 51 Indication RGB insertion

IN1	RGB INSERTION
0	no insertion
1	insertion

Table 52 Output video identification

IFI	VIDEO SIGNAL
0	no video signal identified
1	video signal identified

Table 53 AFC output

AFA	AFB	CONDITION
0	0	outside window; too low
0	1	outside window; too high
1	0	inside window; below reference
1	1	inside window; above reference

Table 54 Crystal indication

SXA	SXB	CRYSTAL
0	0	two 3.6 MHz crystals
0	1	one 3.6 MHz crystal
1	0	one 4.4 MHz crystal
1	1	3.6 MHz and 4.4 MHz crystals

Table 55 Condition vertical divider

IVW	VIDEO SIGNAL
0	no standard video signal detected
1	standard video signal detected (525 or 625 lines)

I²C-bus controlled economy PAL/NTSC and NTSC TV-processors

TDA837x family

Table 56 IC version indication

ID2	ID1	ID0	STANDARD
0	0	0	TDA8373
0	0	1	TDA8377
0	1	0	TDA8374B
0	1	1	TDA8374A
1	0	0	TDA8374
1	0	1	TDA8377A
1	1	0	TDA8375A
1	1	1	TDA8375

LIMITING VALUES

In accordance with the Absolute Maximum Rating System (IEC 134).

SYMBOL	PARAMETER	CONDITIONS	MIN.	MAX.	UNIT
V _P	supply voltage		–	9.0	V
T _{stg}	storage temperature		–25	+150	°C
T _{amb}	operating ambient temperature		0	70	°C
T _{slid}	soldering temperature	for 5 s	–	260	°C
T _j	operating junction temperature		–	150	°C
V _{es}	electrostatic handling	HBM; all pins; notes 1 and 2	–2000	+2000	V
		MM; all pins; notes 1 and 3	–200	+200	V

Notes

- All pins are protected against ESD by means of internal clamping diodes.
- Human Body Model (HBM): R = 1.5 kΩ; C = 100 pF.
- Machine Model (MM): R = 0 Ω; C = 200 pF.

QUALITY SPECIFICATION

In accordance with “SNW-FQ-611E”. The number of the quality specification can be found in the “Quality Reference Handbook”. The handbook can be ordered using the code 9397 750 00192.

Latch-up

- I_{trigger} ≥ 100 mA or ≥ 1.5V_{P(max)}
- I_{trigger} ≤ –100 mA or ≤ –0.5V_{P(max)}.

I²C-bus controlled economy PAL/NTSC and NTSC TV-processors

TDA837x family

CHARACTERISTICS

$V_P = 8\text{ V}$; $T_{\text{amb}} = 25\text{ °C}$; the pin numbers given refer to the SDIP56 package; unless otherwise specified.

SYMBOL	PARAMETER	CONDITIONS	MIN.	TYP.	MAX.	UNIT
Supplies						
MAIN SUPPLY (PIN 12)						
V_{P1}	supply voltage		7.2	8.0	8.8	V
I_{P1}	supply current		–	110	–	mA
P_{tot}	total power dissipation		–	900	–	mW
HORIZONTAL OSCILLATOR SUPPLY (PIN 37)						
V_{P2}	supply voltage		7.2	8.0	8.8	V
I_{P2}	supply current		–	6	–	mA
IF circuit						
VISION IF AMPLIFIER INPUTS (PINS 48 AND 49)						
$V_{i(\text{rms})}$	input sensitivity (RMS value)	note 1 $f_i = 38.90\text{ MHz}$ $f_i = 45.75\text{ MHz}$ $f_i = 58.75\text{ MHz}$	– – –	70 70 70	100 100 100	μV μV μV
R_i	input resistance (differential)	note 2	–	2	–	k Ω
C_i	input capacitance (differential)	note 2	–	3	–	pF
ΔG_v	voltage gain control range		64	–	–	dB
$V_{i(\text{max})(\text{rms})}$	maximum input signal (RMS value)		100	150	–	mV
PLL DEMODULATOR (PLL FILTER ON PIN 5); note 3						
f_{PLL}	PLL frequency range		32	–	60	MHz
$f_{\text{cr(PLL)}}$	PLL catching range		–	2	–	MHz
$t_{\text{acq(PLL)}}$	PLL acquisition time		–	–	20	ms
$\Delta f_{\text{VCO(T)}}$	VCO frequency variation with temperature	note 4	–	tbf	–	kHz/K
$f_{\text{tune(VCO)}}$	VCO tuning range	via the I ² C-bus	–	2.5	–	MHz
Δf_{DAC}	frequency variation per step of the DAC (A0 to A6)		–	20	–	kHz
$f_{\text{shift(L)'}}$	frequency shift with the L' FA bit		–	5.5	–	MHz

I²C-bus controlled economy PAL/NTSC and NTSC TV-processors

TDA837x family

SYMBOL	PARAMETER	CONDITIONS	MIN.	TYP.	MAX.	UNIT	
VIDEO AMPLIFIER OUTPUT (PIN 6); note 5							
V _o	zero signal output level	negative modulation; note 6	–	4.7	–	V	
		positive modulation; note 6	–	2.0	–	V	
V _{6(ts)}	top sync level	negative modulation	1.9	2.0	2.1	V	
V _{6(w)}	white level	positive modulation when available	–	4.5	–	V	
ΔV ₆	difference in amplitude between negative and positive modulation		–	0	15	%	
Z _o	video output impedance		–	50	–	Ω	
I _{bias}	internal bias current of NPN emitter follower output transistor		1.0	–	–	mA	
I _{source(max)}	maximum source current		–	–	5	mA	
B	bandwidth of demodulated output signal	at –3 dB	6	9	–	MHz	
G _{diff}	differential gain	note 7	–	2	5	%	
φ _{diff}	differential phase	notes 4 and 7	–	–	5	deg	
NL _{vid}	video non-linearity	note 8	–	–	5	%	
V _{clamp}	white spot clamp level		–	5.3	–	V	
N _{th(clamp)}	noise inverter threshold clamp level	note 9	–	1.7	–	V	
N _{ins}	noise inverter insertion level	note 9	–	2.6	–	V	
δ	intermodulation	notes 4 and 10					
		blue	V _o = 0.92 or 1.1 MHz	60	66	–	dB
			V _o = 2.66 or 3.3 MHz	60	66	–	dB
		yellow	V _o = 0.92 or 1.1 MHz	56	62	–	dB
		V _o = 2.66 or 3.3 MHz	60	66	–	dB	
S/N	signal-to-noise ratio	notes 4 and 11					
		V _i = 10 mV at end of control range	52	60	–	dB	
			52	61	–	dB	
V _{6(rc)}	residual carrier signal	note 4	–	5.5	–	mV	
V _{6(2H)}	residual 2nd harmonic of carrier signal	note 4	–	2.5	–	mV	

I²C-bus controlled economy PAL/NTSC and NTSC TV-processors

TDA837x family

SYMBOL	PARAMETER	CONDITIONS	MIN.	TYP.	MAX.	UNIT
IF AND TUNER AGC; note 12						
<i>Timing of IF-AGC with a 2.2 μF capacitor (pin 53)</i>						
	modulated video interference	30% AM for 1 to 100 mV; 0 to 200 Hz (system B/G)	–	–	10	%
t _{res(IFinc)}	response time to an IF input signal amplitude increase of 52 dB	positive (when available) and negative modulation	–	2	–	ms
t _{res(IFdec)}	response to an IF input signal amplitude decrease of 52 dB	negative modulation	–	50	–	ms
		positive modulation (when available)	–	100	–	ms
I ₅₃	allowed leakage current of the AGC capacitor	negative modulation	–	–	10	μA
		positive modulation (when available)	–	–	200	nA
<i>Tuner take-over adjustment (via I²C-bus)</i>						
V _{i(min)(rms)}	minimum starting level for tuner take-over (RMS value)		–	0.4	0.8	mV
V _{i(max)(rms)}	maximum starting level for tuner take-over (RMS value)		40	80	–	mV
<i>Tuner control output (pin 54)</i>						
V _{oAGC(max)}	maximum tuner AGC output voltage	maximum tuner gain; note 2	–	–	V _P + 1	V
V _{o(sat)}	output saturation voltage	minimum tuner gain; I ₅₄ = 2 mA	–	–	300	mV
I _{oAGC(max)}	maximum tuner AGC output swing		5	–	–	mA
I _{LI(RF)}	leakage current RF AGC		–	–	1	μA
ΔV _i	input signal variation for a control current variation of 1 mA		0.5	2	4	dB
AFC OUTPUT (VIA I ² C-BUS); note 13						
RES _{AFC}	AFC resolution		–	2	–	bits
W _{sen}	window sensitivity		65	80	100	kHz
W _{senL}	window sensitivity in large window mode		195	240	300	kHz
VIDEO IDENTIFICATION OUTPUT (VIA I ² C-BUS)						
t _d	delay time of identification after the AGC has stabilized on a new transmitter		–	–	10	ms

I²C-bus controlled economy PAL/NTSC and NTSC TV-processors

TDA837x family

SYMBOL	PARAMETER	CONDITIONS	MIN.	TYP.	MAX.	UNIT
Sound circuit						
DEMODULATOR PART						
$V_{i(crPLL)(rms)}$	input limiting voltage for PLL catching range (RMS value)		–	1	2	mV
$f_{cr(PLL)}$	PLL catching range	note 14	4.2	–	6.8	MHz
R_i	input resistance	note 2	–	8.5	–	k Ω
C_i	input capacitance	note 2	–	–	5	pF
AMR	AM rejection	$V_i = 50$ mV (RMS); note 15	60	66	–	dB
DE-EMPHASIS						
$V_{o(rms)}$	output signal amplitude (RMS value)	note 14	–	500	–	mV
R_o	output resistance		–	15	–	k Ω
V_o	DC output voltage		–	3	–	V
AUDIO ATTENUATOR CIRCUIT						
$V_{o(rms)}$	controlled output signal amplitude (RMS value)	at –6 dB; note 14	500	700	900	mV
$V_{oAVL(rms)}$	output signal level when AVL is activated (RMS value)	note 16	300	400	500	mV
$V_{oFAV(rms)}$	output signal level when FAV is activated (RMS value)	note 14	–	500	–	mV
R_o	output resistance		–	500	–	Ω
V_o	DC output voltage		–	3.3	–	V
THD	total harmonic distortion	note 17	–	–	0.5	%
		FAV = 1; note 18	–	–	tbf	%
PSRR	power supply ripple rejection	note 4	–	tbf	–	dB
S/N_{int}	internal signal-to-noise ratio	notes 4 and 19	–	60	–	dB
S/N_{ext}	external signal-to-noise ratio	notes 4 and 19	–	80	–	dB
$T_{dep(out)}$	temperature dependency of output level	notes 4 and 20	–	–	tbf	dB
CR	control range		tbf	80	tbf	dB
VC_{step}	step size volume control		–	1.5	–	dB
	control curve		see Fig.8			
OSS	suppression of output signal when the mute is active		–	80	–	dB
V_{shift}	DC shift of the output level when the mute is activated		–	10	50	mV
EXTERNAL AUDIO INPUT						
$V_{i(rms)}$	input signal amplitude (RMS value)		–	500	1500	mV
R_i	input resistance		–	25	–	k Ω

I²C-bus controlled economy PAL/NTSC and NTSC TV-processors

TDA837x family

SYMBOL	PARAMETER	CONDITIONS	MIN.	TYP.	MAX.	UNIT
$G_{v(in-out)}$	voltage gain between input and output	maximum volume	–	12	–	dB
α_{ct}	crosstalk between audio signals		60	–	–	
AUTOMATIC VOLUME LEVELLING CIRCUIT (TDA8373 AND TDA8374 ONLY; CAPACITOR CONNECTED TO PIN 45)						
G_{max}	gain	maximum boost; note 16	–	6	–	dB
G_{min}	gain	minimum boost	–	–14	–	dB
I_{att}	attack charge current		–	1	–	mA
I_{dec}	decay discharge current		–	200	–	nA
$V_{ctrl(max)}$	control voltage	maximum boost	–	1	–	V
$V_{ctrl(min)}$	control voltage	minimum boost	–	5	–	V
CVBS, Y/C, RGB, CD inputs and luminance input and output						
CVBS AND Y/C SWITCH (PINS 11, 13, 17 AND 38)						
$V_{11(p-p)}$	CVBS or Y input voltage (peak-to-peak value)	note 21	–	1.0	1.4	V
I_{17}	CVBS input current		–	4	–	μ A
SS_{CVBS}	suppression of non-selected CVBS input signal	notes 4 and 22	50	–	–	dB
$V_{10(p-p)}$	chrominance input voltage (burst amplitude) (peak-to-peak value)	notes 2 and 23	–	0.3	0.45	V
$V_{38(p-p)}$	output signal amplitude (peak-to-peak value)		–	1.0	–	V
Z_o	output impedance		–	–	250	Ω
V_{sync}	top sync level		–	2.5	–	V
RGB INPUTS (PINS 23, 24 AND 25)						
$V_{23-25(p-p)}$	input signal amplitude for an output signal of 2 V (black-to-white) (peak-to-peak value)	note 24	–	0.7	0.8	V
$V_{23-25(p-p)}$	input signal amplitude before clipping occurs (peak-to-peak value)	note 4	1.0	–	–	V
ΔV_o	difference between black level of internal and external signals at the outputs		–	–	20	mV
I_{23-25}	input currents	note 2	–	0.1	1	μ A
Δt_d	delay difference for the three channels	note 4	–	0	–	ns
FAST BLANKING (PIN 26)						
V_i	input voltage	no data insertion	–	–	0.3	V
		data insertion	0.9	–	–	V
$V_{26(max)}$	maximum input pulse	insertion	–	–	3.0	V

I²C-bus controlled economy PAL/NTSC and NTSC TV-processors

TDA837x family

SYMBOL	PARAMETER	CONDITIONS	MIN.	TYP.	MAX.	UNIT
$\Delta t_{d(\text{blank,RGB})}$	delay difference of blanking and RGB signals	note 4	–	–	50	ns
t_{sw}	switching speed of blanking circuit		–	10	–	ns
I_{26}	input current		–	–	0.2	mA
SS_{int}	suppression of internal RGB signals	insertion; $f_i = 0$ to 5 MHz; notes 4 and 22	–	55	–	dB
SS_{ext}	suppression of external RGB signals	no insertion; $f_i = 0$ to 5 MHz; notes 4 and 22	–	55	–	dB
V_i	input voltage to insert black level at the RGB outputs to facilitate 'On Screen Display' signals being applied to the outputs		4	–	–	V
$t_{d(\text{blank-RGB})}$	delay between blanking input and RGB outputs		–	–	80	ns
COLOUR DIFFERENCE INPUT SIGNALS (PINS 31 AND 32)						
$V_{31(\text{p-p})}$	input signal amplitude (R – Y) (peak-to-peak value)	note 2	–	1.05	–	V
$V_{32(\text{p-p})}$	input signal amplitude (B – Y) (peak-to-peak value)	note 2	–	1.35	–	V
$I_{31,32}$	input current for both inputs	note 2	–	0.1	1.0	μA
LUMINANCE INPUTS AND OUTPUTS (PINS 27 AND 28); note 25						
$V_{27,28}$	output signal amplitude (black-to-white)		–	1	–	V
Chrominance filters						
CHROMINANCE TRAP CIRCUIT; note 26						
f_{trap}	trap frequency		–	f_{osc}	–	MHz
QF	trap quality factor	note 27	–	2	–	
CSR	colour subcarrier rejection		20	–	–	dB
$f_{\text{trap}(\text{SECAM})}$	trap frequency	during SECAM reception	–	4.3	–	MHz
CHROMINANCE BAND-PASS CIRCUIT						
f_c	centre frequency		–	$1.1f_{\text{osc}}$	–	MHz
Q_{bp}	band-pass quality factor		–	3	–	
Luminance processing						
Y DELAY LINE						
$t_{d(\text{Y})}$	delay time	note 4	–	480	–	ns
$B_{\text{del}(\text{int})}$	bandwidth of internal delay line	note 4	8	–	–	MHz
PEAKING CONTROL; note 28						
t_{W}	width of preshoot or overshoot	at 50% of pulse; note 8	–	160	–	ns

I²C-bus controlled economy PAL/NTSC and NTSC TV-processors

TDA837x family

SYMBOL	PARAMETER	CONDITIONS	MIN.	TYP.	MAX.	UNIT
S _{c(th)}	peaking signal compression threshold		–	50	–	IRE
OS	overshoot at maximum peaking	positive	–	45	–	%
		negative	–	80	–	%
neg/pos	ratio of negative and positive overshoots		–	1.8	–	
	peaking control curve	16 steps	see Fig.9			
NOISE CORING STAGE						
S	coring range		–	15	–	IRE
BLACK LEVEL STRETCHER; note 29						
BL _{shift(max)}	maximum black level shift		15	21	27	IRE
BL _{shift}	level shift	at 100% of peak white	–1	0	+1	IRE
		at 50% of peak white	–1	–	+3	IRE
		at 15% of peak white	6	8	10	IRE
Horizontal and vertical synchronization and drive circuits						
SYNC VIDEO INPUT (PINS 11, 13 AND 17)						
V _{11,13,17}	sync pulse amplitude	note 2	50	300	350	mV
SL _{HS}	slicing level for horizontal sync	note 30	–	50	–	%
SL _{VS}	slicing level for vertical sync	note 30	–	30	–	%
HORIZONTAL OSCILLATOR						
f _{fr}	free running frequency		–	15625	–	Hz
Δf _{fr}	spread on free running frequency		–	–	±2	%
Δf/ΔV _P	frequency variation with respect to the supply voltage	V _P = 8.0 V ±10%; note 4	–	0.2	0.5	%
Δf _{(max)(T)}	maximum frequency variation with temperature	T _{amb} = 0 to 70 °C; note 4	–	–	80	Hz
FIRST CONTROL LOOP (FILTER CONNECTED TO PIN 43); note 31						
f _{hr(PLL)}	holding range PLL		–	±0.9	±1.2	kHz
f _{cr(PLL)}	catching range PLL	note 4	±0.6	±0.9	–	kHz
S/N	signal-to-noise ratio of the video input signal at which the time constant is switched		–	20	–	dB
HYS	hysteresis at the switching point		–	1	–	dB
SECOND CONTROL LOOP (CAPACITOR CONNECTED TO PIN 42)						
Δφ _i /Δφ _o	control sensitivity		–	150	–	μs/μs
t _{cr}	control range from start of horizontal output to flyback at nominal shift position		11	12	–	μs
t _{shift}	horizontal shift range	63 steps	±2	–	–	μs

I²C-bus controlled economy PAL/NTSC and NTSC TV-processors

TDA837x family

SYMBOL	PARAMETER	CONDITIONS	MIN.	TYP.	MAX.	UNIT
$\Delta\phi$	control sensitivity for dynamic phase compensation		–	5.3	–	$\mu\text{s/V}$
V_{prot}	voltage to switch-on the flash protection	note 32	6	–	–	V
$I_{i(\text{prot})}$	input current during protection		–	–	1	mA
HORIZONTAL OUTPUT (PIN 40); note 33						
V_{OL}	LOW level output voltage	$I_o = 10 \text{ mA}$	–	–	0.3	V
$I_{o(\text{max})}$	maximum allowed output current		10	–	–	mA
$V_{o(\text{max})}$	maximum allowed output voltage		–	–	V_P	V
δ	duty factor	note 4	–	50	–	%
		$V_o = \text{HIGH}$	–	75	–	%
f_{sw}	frequency during switch-on and switch-off		–	$2f_H$	–	Hz
t_{sw}	switch-on time		–	50	–	ms
		maximum RGB drive	–	100	–	ms
		minimum RGB drive	–	50	–	ms
FLYBACK PULSE INPUT AND SANDCASTLE OUTPUT (PIN 41)						
$I_{i(\text{fb})}$	required input current during the flyback pulse	note 4	100	–	300	μA
V_{41}	output voltage	during burst key	4.8	5.3	5.8	V
		during blanking	1.8	2.0	2.2	V
$V_{i(\text{clamp})}$	clamped input voltage during flyback		2.6	3.0	3.4	V
t_W	pulse width	burst key pulse	3.3	3.5	3.7	μs
		vertical blanking; note 34	–	14	–	lines
$t_{d(\text{bk-sync})}$	delay of start of burst key to start of sync		5.2	5.4	5.6	μs
VERTICAL OSCILLATOR; TDA8373 AND TDA8377 OPERATING AT 60 Hz; note 35						
f_{fr}	free running frequency		–	50/60	–	Hz
f_{lock}	frequency locking range		45	–	64.5	Hz
		divider value not locked	–	625/525	–	lines
LR	locking range		488	–	722	lines/ frame
VERTICAL RAMP GENERATOR (PINS 51 AND 52)						
$V_{51(\text{p-p})}$	sawtooth amplitude (peak-to-peak value)	$V_S = 1\text{FH};$ $C = 100 \text{ nF}; R = 39 \text{ k}\Omega$	–	3.5	–	V
I_{dch}	discharge current		–	1	–	mA
I_{ch}	charge current set by external resistor	note 36	–	19	–	μA
V_{slope}	vertical slope	control range (63 steps)	–20	–	+20	%

I²C-bus controlled economy PAL/NTSC and NTSC TV-processors

TDA837x family

SYMBOL	PARAMETER	CONDITIONS	MIN.	TYP.	MAX.	UNIT
ΔI_{ch}	charge current increase	f = 60 Hz	–	20	–	%
V_{rampL}	LOW voltage level of ramp in the normal or expand mode		–	2.07	–	V
VERTICAL DRIVE OUTPUTS (PINS 46 AND 47)						
$I_{o(dif)(p-p)}$	differential output current (peak-to-peak value)	VA = 1FH	–	0.95	–	mA
I_{CM}	common mode current		–	400	–	μ A
$V_{46,47}$	output voltage range		0	–	4.0	V
EHT TRACKING/OVERVOLTAGE PROTECTION (PIN 50)						
ΔV_{50}	input voltage range		1.2	–	2.8	V
m_{scan}	scan modulation range		–5	–	+5	%
V_{sen}	vertical sensitivity		–	6.3	–	%/V
EW_{sen}	E-W sensitivity	when switched on	–	–6.3	–	%/V
I_{eq}	E-W equivalent output current		+100	–	–100	μ A
V_{50}	overvoltage detection level	note 32	–	3.9	–	V
DE-INTERLACE						
ff_d	first field delay		–	0.5H	–	
E-W WIDTH (TDA8375A, TDA8377A, TDA8375 AND TDA8377); note 37						
CR	control range	63 steps	100	–	65	%
I_{eq}	equivalent E-W output current		0	–	700	μ A
V_{oEW}	E-W output voltage range		1.0	–	8.0	V
I_{oEW}	E-W output current range		0	–	1200	μ A
E-W PARABOLA/WIDTH (TDA8375A, TDA8377A, TDA8375 AND TDA8377)						
CR	control range	63 steps	0	–	22	%
I_{eq}	equivalent E-W output current	E-W = 3FH	0	–	440	μ A
E-W CORNER/PARABOLA (TDA8375A, TDA8377A, TDA8375 AND TDA8377)						
CR	control range	63 steps	–43	–	0	%
I_{eq}	equivalent E-W output current	PW = 3FH; E-W = 3FH	–190	–	0	μ A
E-W TRAPEZIUM (TDA8375A, TDA8377A, TDA8375 AND TDA8377)						
CR	control range	63 steps	–5	–	+5	%
I_{eq}	equivalent E-W output current		–100	–	+100	μ A
VERTICAL AMPLITUDE						
CR	control range	63 steps; SC = 00H	80	–	120	%
$I_{eq(dif)(p-p)}$	equivalent differential vertical drive output current (peak-to-peak value)	SC = 00H	760	–	1140	μ A
VERTICAL SHIFT						
CR	control range	63 steps	–5	–	+5	%
$I_{eq(dif)}$	equivalent differential vertical drive output current		–50	–	+50	μ A

I²C-bus controlled economy PAL/NTSC and NTSC TV-processors

TDA837x family

SYMBOL	PARAMETER	CONDITIONS	MIN.	TYP.	MAX.	UNIT
S-CORRECTION						
CR	control range	63 steps	0	–	30	%
VERTICAL EXPAND (ZOOM) MODE (TDA8375 AND TDA8377); note 38						
<i>Output current variation compared with nominal scan</i>						
ΔI_o	vertical expand factor		0.75		1.38	A
$I_{o(lim)}$	output current limiting and RGB blanking			1.08		A
Colour demodulation part						
CHROMINANCE AMPLIFIER						
CR _{ACC}	ACC control range	note 39	26	–	–	dB
ΔV_{ACC}	change in amplitude of the output signals over the ACC range		–	–	2	dB
th _{on}	threshold colour killer ON		–30	–	–	dB
hy _{off}	hysteresis colour killer OFF	at strong signal conditions; S/N ≥ 40 dB; note 4	–	+3	–	dB
		at noisy input signals; note 4	–	+1	–	dB
ACL CIRCUIT; note 40						
	chrominance burst ratio at which the ACL starts to operate		–	3.0	–	
REFERENCE PART						
<i>Phase-locked loop; note 41</i>						
f _{cr}	frequency catching range		±360	±600	–	Hz
$\Delta\phi$	phase shift for a ±400 Hz deviation of the oscillator frequency	note 4	–	–	2	deg
<i>Oscillator</i>						
TC _{osc}	temperature coefficient of the oscillator frequency	note 4	–	2.0	2.5	Hz/K
Δf_{osc}	oscillator frequency deviation with respect to the supply	V _P = 8 V ±10%; note 4	–	–	250	Hz
R _{neg(min)}	minimum negative resistance		–	–	1	kΩ
C _{L(max)}	maximum load capacitance		–	–	15	pF
HUE CONTROL						
CR _{hue}	hue control range	63 steps	±35	±40	–	deg
	hue control curve		see Fig.10			

I²C-bus controlled economy PAL/NTSC and NTSC TV-processors

TDA837x family

SYMBOL	PARAMETER	CONDITIONS	MIN.	TYP.	MAX.	UNIT
Δhue	hue variation for $\pm 10\%$ V_P	note 4	–	0	–	deg
$\Delta\text{hue}(T)$	hue variation with temperature	$T_{\text{amb}} = 0$ to 70 °C; note 4	–	0	–	deg
DEMODULATORS (PINS 29 AND 30)						
$V_{30(p-p)}$	(R – Y) output signal amplitude (peak-to-peak value)	TDA8374 and TDA8375; note 42	–	0.525	–	V
$V_{29(p-p)}$	(B – Y) output signal amplitude (peak-to-peak value)	TDA8374 and TDA8375; note 42	–	0.675	–	V
G	gain ratio between both demodulators $G_{(B-Y)}$ and $G_{(R-Y)}$		1.60	1.78	1.96	
ΔV	spread of signal amplitude ratio PAL/NTSC	TDA8374 and TDA8375; note 4	–1	–	+1	dB
Z_o	output impedance between (R – Y) and (B – Y)	note 2	–	500	–	Ω
B	bandwidth of demodulators	–3 dB; note 43	–	650	–	kHz
$V_{29,30(p-p)}$	residual carrier output (peak-to-peak value)	f_c ; (R – Y) output			5	mV
		f_c ; (B – Y) output	–	–	5	mV
		$2f_c$; (R – Y) output			5	mV
		$2f_c$; (B – Y) output	–	–	5	mV
$V_{30(p-p)}$	H/2 ripple at (R – Y) output (peak-to-peak value)		–	–	25	mV
$\Delta V_{o(T)}$	change of output signal amplitude with temperature	note 4	–	0.1	–	%/K
$\Delta V_o/V_P$	change of output signal amplitude with supply voltage	note 4	–	–	± 0.1	dB
E_ϕ	phase error in the demodulated signals	note 4	–	–	± 5	deg
COLOUR DIFFERENCE MATRICES (IN CONTROL CIRCUIT) TDA8374 AND TDA8375						
<i>PAL or (SECAM when TDA8395 is applied); (R – Y) and (B – Y) not affected</i>						
$(G - Y)/(R - Y)$	ratio of demodulated signals		–	$-0.51 \pm 10\%$	–	
$(G - Y)/(B - Y)$	ratio of demodulated signals		–	$-0.19 \pm 25\%$	–	
<i>NTSC mode; the colour-difference matrix results in the following signals (nominal hue setting)</i>						
(B – Y)	(B – Y) signal $2.03/0^\circ$		$2.03U_R$			
(R – Y)	(R – Y) signal $1.59/95^\circ$		$-0.14U_R + 1.58V_R$			
(G – Y)	(G – Y) signal $0.61/240^\circ$		$-0.31U_R - 0.53V_R$			

I²C-bus controlled economy PAL/NTSC and NTSC TV-processors

TDA837x family

SYMBOL	PARAMETER	CONDITIONS	MIN.	TYP.	MAX.	UNIT
COLOUR DIFFERENCE MATRICES (IN CONTROL CIRCUIT) TDA8373 AND TDA8377						
<i>MAT = 0; the colour-difference matrix results in the following signals (nominal hue setting)</i>						
(B – Y)	(B – Y) signal 2.03/0°		2.03U _R			
(R – Y)	(R – Y) signal 1.59/95°		–0.14U _R + 1.58V _R			
(G – Y)	(G – Y) signal 0.61/240°		–0.31U _R – 0.53V _R			
<i>MAT = 1; the colour-difference matrix results in the following signals (nominal hue setting)</i>						
(B – Y)	(B – Y) signal 1.14/–10°		1.12U _R – 0.20V _R			
(R – Y)	(R – Y) signal 1.14/100°		–0.20U _R + 1.12V _R			
(G – Y)	(G – Y) signal 0.30/235°		–0.17U _R – 0.25V _R			
REFERENCE SIGNAL OUTPUT (PIN 33); note 44						
f _{ref}	reference frequency		–	3.58 or 4.43	–	MHz
V _{33(p-p)}	output signal amplitude (peak-to-peak value)		0.2	0.25	0.3	V
COMMUNICATION WITH THE TDA8395 (TDA8374 AND TDA8375 ONLY)						
V _o	output level	PAL/NTSC identified	–	1.5	–	V
		no PAL/NTSC identified; SECAM (by TDA8395) identified	–	5.0	–	V
I ₃₁	required current to stop PAL/NTSC identification circuit during SECAM		150	–	–	µA
Control part						
SATURATION CONTROL; note 24 (SEE Fig.11)						
CR _{sat}	saturation control range	63 steps	52	–	–	dB
CONTRAST CONTROL; note 24 (SEE Fig.12)						
CR _{con}	contrast control range	63 steps	–	15	–	dB
	tracking between the three channels over a control range of 10 dB		–	–	0.5	dB
BRIGHTNESS CONTROL (SEE Fig.13)						
CR _{bri}	brightness control range	63 steps	–	±0.7	–	V
RGB OUTPUT SIGNALS (PINS 19 TO 21)						
V _{19-21(p-p)}	output signal amplitude at nominal luminance input signal, nominal contrast and white point adjustment (peak-to-peak value)	note 24	1.8	2.1	2.4	V
V _{o(max)(p-p)}	output signal at maximum white point setting (peak-to-peak value)		–	3.0	–	V

I²C-bus controlled economy PAL/NTSC and NTSC TV-processors

TDA837x family

SYMBOL	PARAMETER	CONDITIONS	MIN.	TYP.	MAX.	UNIT
$V_{BW(max)(p-p)}$	maximum signal amplitude (black-to-white)	note 45	–	2.6	–	V
$V_{WP(max)(p-p)}$	maximum signal amplitude at maximum white point setting (peak-to-peak value)		–	3.6	–	V
$V_{red(p-p)}$	output signal amplitude for the 'red' channel at nominal settings for contrast and saturation control and no luminance signal to the input (R – Y, PAL) (peak-to-peak value)		tbf	2.1	tbf	V
ΔV_{blank}	difference between blanking level measuring pulse		0.7	0.8	0.9	V
$t_{W(blank)}$	width of the video blanking pulse when the HBL bit is active	TDA8375, TDA8377, TDA8375A and TDA8377A; note 46	14.4	14.7	15.0	μ s
I_{bias}	internal bias current of NPN emitter follower output transistor		–	1.5	–	mA
I_o	available output current		–	5	–	mA
Z_o	output impedance		–	150	–	Ω
CR_{bl}	control range of the black current stabilization	at $V_{bl} = 2.5$ V and nominal brightness and white-point adjustment (with respect to the measuring pulse)	–	–	± 1	V
V_{bl}	black level shift with picture content	note 4	–	–	20	mV
$V_{o(4L)}$	output voltage of the 4-L pulse after switch-on		–	4.2	–	V
$\Delta bl(T)$	variation of black level with temperature	note 4	–	1.0	–	mV/K
Δbl	relative variation in black level between the three channels during variations of	note 4				
	supply voltage ($\pm 10\%$)	nominal controls	–	–	20	mV
	saturation (50 dB)	nominal contrast	–	–	20	mV
	contrast (15 dB)	nominal saturation	–	–	20	mV
	brightness (± 0.5 V)	nominal controls	–	–	20	mV
	temperature (range 40 °C)		–	–	20	mV
S/N	signal-to-noise ratio of the output signals	RGB input; note 47	60	–	–	dB
		CVBS input; note 47	50	–	–	dB
$V_{r(p-p)}$	residual voltage at the RGB outputs (peak-to-peak value)	at f_{osc}	–	–	15	mV
		at $2f_{osc}$ plus higher harmonics in RGB outputs	–	–	15	mV

I²C-bus controlled economy PAL/NTSC and NTSC TV-processors

TDA837x family

SYMBOL	PARAMETER	CONDITIONS	MIN.	TYP.	MAX.	UNIT
B	bandwidth of output signals	RGB input at -3 dB	8	–	–	MHz
		CVBS input at -3 dB; f _{osc} = 3.6 MHz	–	2.8	–	MHz
		CVBS input at -3 dB; f _{osc} = 4.44 MHz	–	3.5	–	MHz
		S-VHS input; at -3 dB	5	–	–	MHz
WHITE-POINT ADJUSTMENT						
	I ² C-bus setting for nominal gain	HEX code	–	20H	–	
G _{inc(max)}	maximum increase of the gain	HEX code 3FH	40	50	60	%
G _{dec(max)}	maximum decrease of the gain	HEX code 00H	35	45	55	%
BLACK CURRENT STABILIZATION (PIN 18); note 48						
I _{bias}	bias current for the picture tube cathode	nominal white point setting	–	10	–	μA
I _L	acceptable leakage current		–	±100	–	μA
I _{scan(max)}	maximum current during scan		–	0.3	–	mA
Z _i	input impedance		–	15	–	kΩ
BEAM CURRENT LIMITING/VERTICAL GUARD INPUT (PIN 22); note 49						
V _{CR}	contrast reduction starting voltage		–	3.1	–	V
V _{difCR}	voltage difference for full contrast reduction		–	2	–	V
V _{BR}	brightness reduction starting voltage		–	1.6	–	V
V _{difBR}	voltage difference for full brightness reduction		–	1	–	V
V _{bias}	internal bias voltage		–	3.3	–	V
Z _{int}	internal impedance		–	40	–	kΩ
V _{det}	detection level for vertical guard		–	3.65	–	V
I _{i(min)}	minimum input current to activate the guard circuit		–	100	–	μA
I _{i(max)}	maximum allowable input current		–	1	–	mA

Notes

1. On set AGC.
2. This parameter is not tested during production and is just given as application information for the designer of the television receiver.
3. Loop bandwidth B_L = 60 kHz (natural frequency f_n = 15 kHz; damping factor d = 2; calculated with sync level as FPLL input signal level). LC-VCO circuit: Q₀ ≥ 60, C_{ext} = 12 pF, C_{int} = 20 pF.
4. This parameter is not tested during production but is guaranteed by the design and qualified by means of matrix batches which are made in the pilot production period.
5. Measured at 10 mV (RMS) top sync input signal.
6. So called projected zero point, i.e. with switched demodulator.

I²C-bus controlled economy PAL/NTSC and NTSC TV-processors

TDA837x family

7. Measured in accordance with the test line given in Fig.14. For the differential phase test the peak white setting is reduced to 87%.
 - a) The differential gain is expressed as a percentage of the difference in peak amplitudes between the largest and smallest value relative to the subcarrier amplitude at blanking level.
 - b) The phase difference is defined as the difference in degrees between the largest and smallest phase angle.
8. This figure is valid for the complete video signal amplitude (peak white-to-black), see Fig.15.
9. The noise inverter is only active in the 'strong signal mode' (no noise detected in the incoming signal).
10. The test set-up and input conditions are given in Fig.16. The figures are measured with an input signal of 10 mV (RMS).
11. Measured with a source impedance of 75 Ω , where: $S/N = 20 \log \frac{V_{O(b-w)}}{V_{m(rms)} (B = 5 \text{ MHz})}$
12. The AGC response time is also dependent on the acquisition time of the PLL demodulator. The values given are valid when the PLL is in lock.
13. The AFC control voltage is obtained from the control voltage of the VCO of the PLL demodulator. The tuning information is supplied to the tuning system via the I²C-bus. Two bits are reserved for this function. The AFC value is valid only when the SL bit = 1.
14. $V_i = 100 \text{ mV (RMS)}$, FM: 1 kHz, $\Delta f = \pm 50 \text{ kHz}$.
15. $V_i = 50 \text{ mV (RMS)}$, $f = 4.5 \text{ to } 5.5 \text{ MHz}$; FM: 70 Hz, $\pm 50 \text{ kHz}$ deviation; AM: 1 kHz, 30% modulation.
16. The Automatic Volume Levelling (AVL) circuit automatically stabilizes the audio output signal to a certain level which can be set by means of the volume control. This AVL function prevents big audio output fluctuations due to variation of the modulation depth of the transmitter. The AVL can be switched on and off via the I²C-bus.
For the TDA8373 the AVL is active over an input voltage range (measured at the de-emphasis output) between 75 and 750 mV (RMS). For the TDA8374 this input level is dependent on the crystals which are connected to the colour decoder. When only 3.5 MHz crystals are connected (indicated via the XA/XB bits) the active input level is identical to that of the TDA8373. When a 4.4 MHz crystal is connected the input signal range is increased to 150 to 1500 mV (RMS), this to cope with the larger FM swing of European transmitters.
The AVL control curve for the 2 standards is given in Fig.29 and Fig.30. The control range of +6 to -14 dB is valid for input signals with 50% of the maximum frequency deviation.
17. $V_i = 100 \text{ mV (RMS)}$, $f = 5.5 \text{ MHz}$; FM: 1 kHz, $\pm 17.5 \text{ kHz}$ deviation, 15 kHz bandwidth; audio attenuator at -6 dB.
18. $V_i = 100 \text{ mV (RMS)}$, $f = 4.5 \text{ to } 5.5 \text{ MHz}$, FM: 1 kHz, $\pm 100 \text{ kHz}$ deviation.
19. Unweighted RMS value, $V_i = 100 \text{ mV (RMS)}$, FM: 1 kHz, $\pm 50 \text{ kHz}$ deviation, volume control: -6 dB.
20. Audio attenuator at -20 dB; temperature range = 10 to 50 $^{\circ}\text{C}$.
21. Signal with negative-going sync. Amplitude includes sync pulse amplitude.
22. This parameter is measured at nominal settings of the various controls.
23. Indicated as a signal for a colour bar with 75% saturation (chroma-to-burst ratio = 2.2 : 1).
24. Nominal contrast is specified with the DAC in position 20H. Nominal saturation as maximum -10 dB. At nominal settings of brightness and white point the black level at the outputs is 300 mV lower than the level of the black current measuring pulses.
25. The luminance output and input of the TDA8375A, TDA8377A, TDA8375 and TDA8377 can be connected directly. When additional picture improvement ICs (such as the TDA9170) are applied the inputs of these ICs must be AC-coupled because of the black level clamp requirement. The output of the picture improvement ICs can be directly coupled to the luminance input as long as the DC level of the signal has a value between 1 and 7 V.
To be able to apply CTI ICs such as the TDA4565 and TDA4566 the gain of the luminance channel can be increased via the setting of the GAI bit in the I²C-bus subaddress 03.

I²C-bus controlled economy PAL/NTSC and NTSC TV-processors

TDA837x family

26. When the colour decoder is forced to a fixed subcarrier frequency (via the XA/XB or the CM bits) the chroma trap is always switched on, also when no colour signal is identified. When 2 crystals are active the chroma trap is switched off when no colour signal is identified.

27. The -3 dB bandwidth of the circuit can be calculated using the following equation:

$$f_{-3 \text{ dB}} = f_{\text{osc}} \left(1 - \frac{1}{2Q} \right)$$

28. Valid for a signal amplitude on the Y input of 0.7 V (black-to-white) (100 IRE) with a rise time (10% to 90%) of 70 ns and the video switch in the Y/C mode. During production the peaking function is not tested by measuring the overshoots but by measuring the frequency response of the Y output.

29. For video signals with a black level which deviates from the back porch blanking level the signal is 'stretched' to the blanking level. The amount of correction depends on the IRE value of the signal (see Fig.17). The black level is detected by means of an external capacitor. The black level stretcher can be made inoperative by connecting the pin to ground. The values given are valid only when the luminance input signal has an amplitude of 1 V (p-p).

30. The slicing level is independent of sync pulse amplitude. The given percentage is the distance between the slicing level and the black level (back porch). When the amplitude of the sync pulse exceeds the value of 350 mV the sync separator will slice the sync pulse at a level of 175 mV above top sync. The maximum sync pulse amplitude is 4 V (p-p).

31. To obtain a good performance for both weak signal and VCR playback the time constant of the first control loop is switched depending on the input signal condition and the condition of the bus. Therefore the circuit contains a noise detector and the time constant is switched to 'slow' when too much noise is present in the signal. In the 'fast' mode, during the vertical retrace time, the phase detector current is increased by 50% so that phase errors due to the head switching of the VCR are corrected as soon as possible. Switching between the two modes can be made automatically or overruled by the bus (see Tables 4, 6, 8 and 10).

The circuit contains a video identification circuit which is independent of first loop. This identification circuit can be used to close or open the first control loop when a video signal is present or not on the input. This ensures a stable On-Screen-Display (OSD) when just noise is present at the input. The coupling of the video identification circuit with the first loop can be overruled via the I²C-bus. The coupling between the phase 1 detector and the video identification circuit is only active for 'internal' CVBS signals.

To prevent the horizontal synchronization being disturbed by anti-copy guard signals, such as Macrovision, the phase detector is gated during the vertical retrace period so that pulses during scan have no effect on the output voltage. The width of the gate pulse is approximately 22 μs. Furthermore the phase detector is gated during the lower part of the picture (pulse width = 12 μs) to prevent disturbances due to overmodulated subtitles. The latter gating is active only with standard signals (number of lines per frame 625 or 525). During weak signal conditions (noise detector active) the gating is active during the complete scan period and the width of the gate pulse is reduced to 5.7 μs so that the effect of the noise is reduced to a minimum. The output current of the phase detector in the various conditions are given in Table 57.

32. The ICs have 2 protection inputs.

The protection at pin 42 is intended to be used as 'flash' protection. When this protection is activated the horizontal drive is switched off immediately and then switched on again via the slow start procedure.

The protection on pin 50 is intended for overvoltage (X-ray) protection. When this protection is activated the horizontal drive can be switched off directly (via the slow stop procedure). It is also possible to continue the horizontal drive and to set the protection bit (XPR) in the output bytes of the I²C-bus. The choice between the 2 modes of operation is made with the PRD bit.

I²C-bus controlled economy PAL/NTSC and NTSC TV-processors

TDA837x family

33. During switch-on the horizontal output starts with twice the frequency and with a duty cycle of 75% ($V_o = \text{HIGH}$). After approximately 50 ms the frequency is changed to the normal value. Because of the high frequency the peak currents in the horizontal output transistor are limited. Also during switch-off the frequency is switched to twice the value and the RGB drive is set to maximum so that the EHT capacitor is discharged. This switching to maximum drive occurs only when $\text{RBL} = 0$, for $\text{RBL} = 1$ the drive voltage remains minimum during switch-off. After approximately 100 ms the RGB drive is set to minimum and 50 ms later the horizontal drive is switched off. The horizontal output is gated with the flyback pulse so that the horizontal output transistor cannot be switched on during the flyback time.
34. The vertical blanking pulse in the RGB outputs has a width of 26 or 21 lines (50 or 60 Hz system). The width of the vertical sync pulse in the sandcastle pulse has a width of 14 lines. This to prevent a phase distortion on top of the picture due to timing modulation of the incoming flyback pulse.
35. The timing pulses for the vertical ramp generator are obtained from the horizontal oscillator via a divider circuit. This divider circuit has 3 modes of operation. A brief explanation is given below. For the TDA8373 and TDA8377 only the 60 Hz figures are valid.
- Search mode 'large window':
This mode is switched on when the circuit is not synchronized or when a non-standard signal (number of lines per frame in the 50 Hz mode is between 311 and 314 and in the 60 Hz mode between 261 and 264) is received. In the search mode the divider can be triggered between line 244 and line 361 (approximately 45 to 64.5 Hz).
 - Standard mode 'narrow window':
This mode is switched on when more than 15 succeeding vertical sync pulses are detected in the narrow window. When the circuit is in the standard mode and a vertical sync pulse is missing the retrace of the vertical ramp generator is started at the end of the window. Consequently, the disturbance of the picture is very small. The circuit will switch back to the search window when, for 6 successive vertical periods, no sync pulses are found within the window.
 - Standard TV-norm (divider ratio 525 (60 Hz) or 625 (50 Hz)):
When the system is switched to the narrow window it is checked whether the incoming vertical sync pulses are in accordance with the TV-norm. When 15 standard TV-norm pulses are counted the divider system is switched to the standard divider ratio mode. In this mode the divider is always reset at the standard value even if the vertical sync pulse is missing.
When 3 vertical sync pulses are missed the system switches back to the narrow window and when also in this window no sync pulses are found (condition 3 missing pulses) the system switches over to the search window.
The vertical divider needs some waiting time during channel-switching of the tuner. When a fast reaction of the divider is required during channel-switching the system can be forced to the search window by means of the NCIN bit in subaddress 08.
36. Conditions: frequency is 60 Hz; normal mode; $\text{VS} = 1\text{F}$.
37. The output range percentages mentioned for E-W control parameters are based on the assumption that $400 \mu\text{A}$ variation in E-W output current is equivalent to 20% variation in picture width. Because of the horizontal and vertical zoom feature in the TDA8375 and TDA8377 (see also note 38) the E-W width control range is increased compared with previous ICs such as the TDA8366. The increased E-W width control is also available in the TDA8375A and TDA8377A although these devices do not have the vertical zoom feature.
38. The TDA8375 and TDA8377 have a zoom adjustment possibility for the vertical and horizontal deflection. For this reason an extra DAC has been added in the vertical amplitude control which controls the vertical scan amplitude between 0.75 and 1.38 of the nominal scan. At an amplitude of 1.08 of the nominal scan the output current is limited and the blanking of the RGB outputs is activated (see Fig.28). In addition to the variation of the vertical amplitude the vertical slope control range is also increased. This gives the possibility to vary the position of the bottom part of the picture independent from the upper part. The nominal scan height must be adjusted at a position of 19H of the vertical 'zoom' DAC

I²C-bus controlled economy PAL/NTSC and NTSC TV-processors

TDA837x family

39. At a chrominance input voltage of 660 mV (p-p) [colour bar with 75% saturation i.e. burst signal amplitude 300 mV (p-p)] the dynamic range of the ACC is +6 and -20 dB.
40. The ACL function is available in the NTSC devices and is active in the PAL/NTSC devices when NTSC signals are received. The ACL circuit reduces the gain of the chroma amplifier for input signals with a chroma-to-burst ratio which exceeds a value of 3.0.
41. All frequency variations are referenced to 3.58 or 4.43 MHz carrier frequency. All oscillator specifications are measured with the Philips crystal series 9922 520 with a series capacitor of 18 pF. The oscillator circuit is rather insensitive to the spurious responses of the crystal. As long as the resonance resistance of the 3rd overtone is higher than that of the fundamental frequency the oscillator will operate at the correct frequency. Typical parameters for the above mentioned crystals are as follows:
- Load resonance frequency $f_0 = 4.433619$ or 3.579545 MHz ($C_L = 20$ pF).
 - Motional capacitance $C_{mot} = 20.6$ fF (4.43 MHz crystal) or 14.7 fF (3.58 MHz crystal).
 - Parallel capacitance $C_{par} = 5$ pF for both crystals.

The minimum detuning range can only be specified if both the IC and the crystal tolerances are known and the figures given are therefore valid for the specified crystal series. In this figure tolerances of the crystal with respect to nominal frequency, motional capacitance and ageing have been taken into account and have been counted for gaussian addition. Whenever different typical crystal parameters are used the following equation might be helpful for calculating the impact on the detuning capabilities:

The detuning range divided by
$$\left(\frac{C_{mot}}{1 + \frac{C_{par}}{C_L}} \right)^2$$

The resulting detuning range should be corrected for temperature shift and supply deviation of both the IC and the crystal. The actual series capacitance in the application should be $C_L = 18$ pF to account for parasitic capacitances on and off chip. For 3-norma applications with 2 crystals connected to one pin the maximum parasitic capacitance of the crystal pin should not exceed 15 pF.

42. The (R - Y) and (B - Y) signals are demodulated with a phase difference of the reference carrier of 90° and a gain ratio $\frac{(B - Y)}{(R - Y)} = 1.78$.
- The output signal amplitudes of the TDA8373 and TDA8377A have twice the value. This is necessary to compensate for the gain of the baseband delay line (TDA4665). The matrixing to the required signals is realized in the control part.
43. This parameter indicates the bandwidth of the complete chrominance circuit including the chrominance band-pass filter. The bandwidth of the low-pass filter of the demodulator is approximately 1 MHz.
44. The sub-carrier output signal can be used as reference signal of external comb filter ICs (all ICs) and as a reference signal for the SECAM decoder TDA8395 (only TDA8374 and TDA8375). In the latter types the output signal is continuously available when PAL or NTSC signals are detected. When the system identifies a SECAM signal the reference signal is only present in the vertical retrace period. This to prevent interference between the reference signal and the SECAM input signal. For comb filter applications the DC load on this pin should be limited to 50 µA to avoid problems with SECAM identification.
45. At nominal setting of the gain control. When this amplitude is exceeded the signal will be clipped.
46. When the reproduction of 4 : 3 pictures on a 16 : 9 picture tube is realized by means of a reduction of the horizontal scan amplitude, the edges of the picture may be slightly disturbed. This effect can be prevented by adding additional blanking to the RGB signals. This blanking pulse is derived from the horizontal oscillator and is directly related to the incoming video signal (independent of the flyback pulse). The additional blanking overlaps the normal blanking signal with approximately 1 µs on both sides. This blanking is activated with the HBL bit (only in the TDA8375 and TDA8377).
47. Signal-to-noise ratio (S/N) is specified as a peak-to-peak signal with respect to RMS noise (bandwidth 5 MHz).

I²C-bus controlled economy PAL/NTSC and NTSC TV-processors

TDA837x family

48. This is a current input. The indicated value of the nominal bias current is obtained at the nominal setting of the gain (white point) control. The actual value of the bias current depends on the gain control setting of each channel. As a result the 'black current' of each gun is adapted to the white point setting so that the background colour will follow the white point adjustment.
49. The beam current limiting and the vertical guard function have been combined on this pin. The beam current limiting function is active during the vertical scan period.

Table 57 Output current of the phase detector in the various conditions

I ² C-BUS COMMANDS				IC CONDITIONS			φ-1 CURRENT/MODE			
VID	POC	FOA	FOB	IDENT	COIN	NOISE	SCAN	V-RETR	GATING	MODE
–	0	0	0	yes	yes	no	180	270	yes ⁽¹⁾	auto
–	0	0	0	yes	yes	yes	30	30	yes	auto
–	0	0	0	yes	no	–	180	270	no	auto
–	0	0	1	yes	yes	–	30	30	yes	slow
–	0	0	1	yes	no	–	180	270	no	slow
–	0	1	0	yes	yes	no	180	270	yes	fast
–	0	1	0	yes	yes	yes	30	30	yes	slow
–	–	1	1	–	–	–	180	270	no	fast
0	0	–	–	no	–	–	6	6	no	OSD
–	1	–	–	–	–	–	–	–	–	off

Note

1. During vertical retrace the width is 22 μs and during the lower part of the picture 12 μs. In the other conditions the width is 5.7 μs and the gating is continuous.

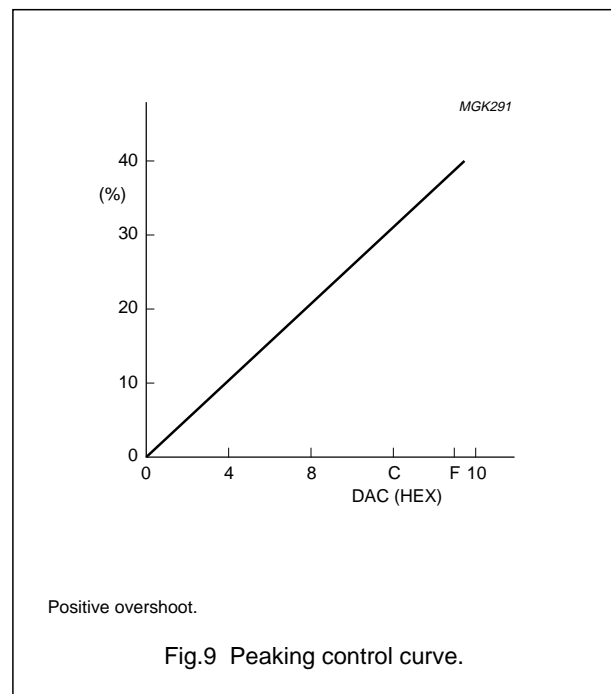
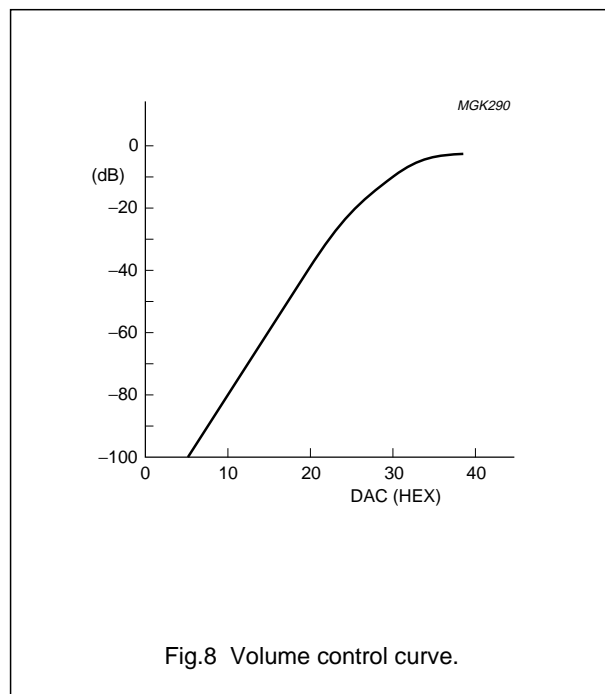

I²C-bus controlled economy PAL/NTSC
and NTSC TV-processors

TDA837x family

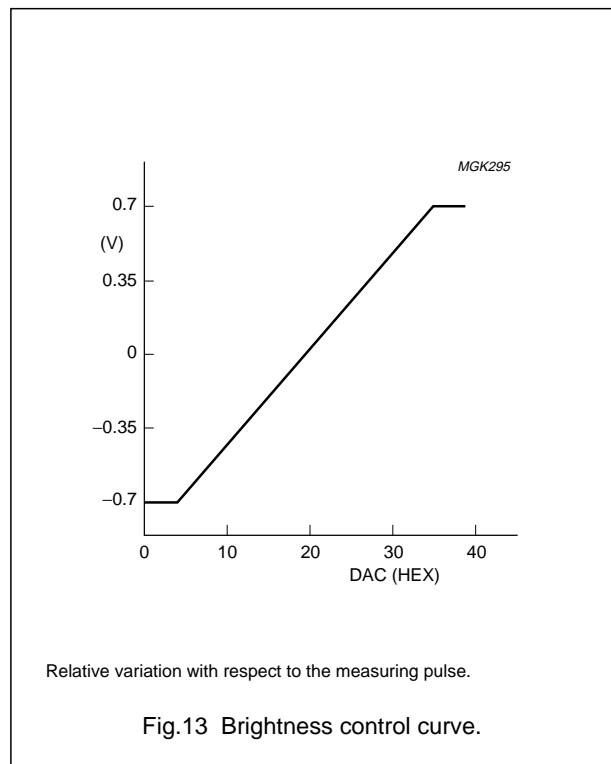
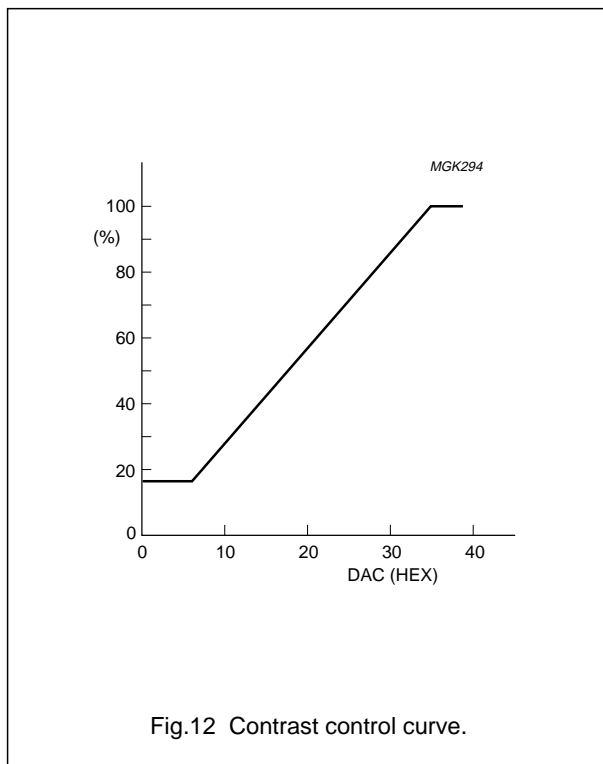
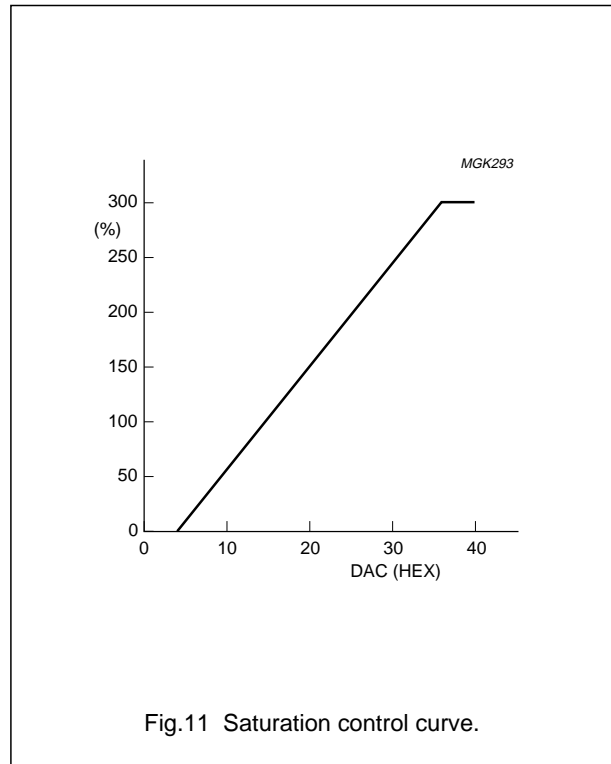
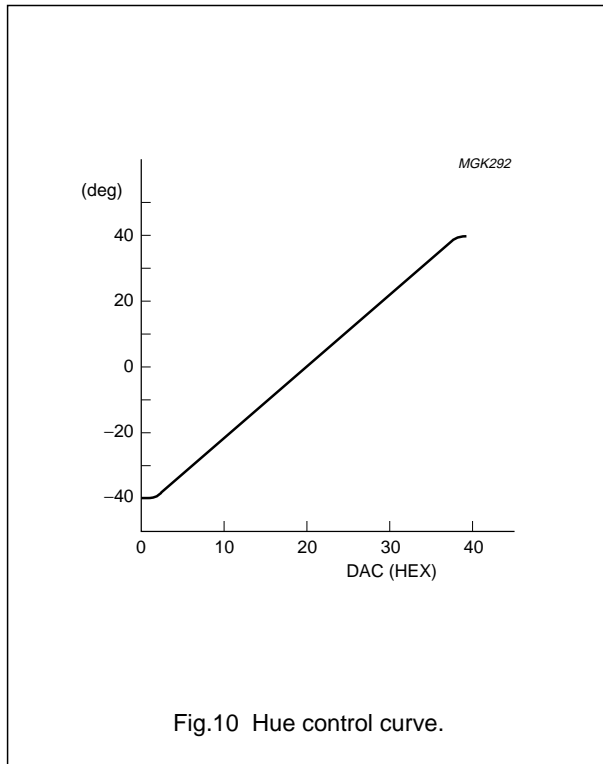

I²C-bus controlled economy PAL/NTSC
and NTSC TV-processors

TDA837x family

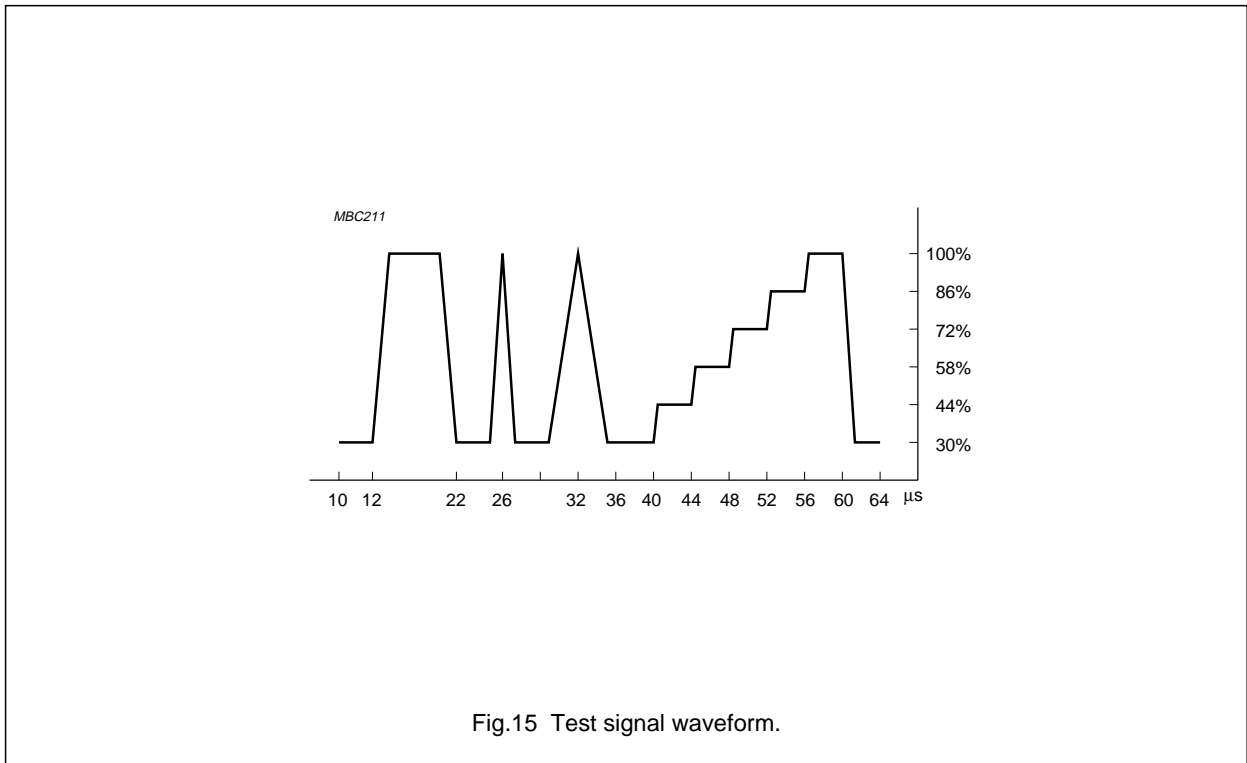
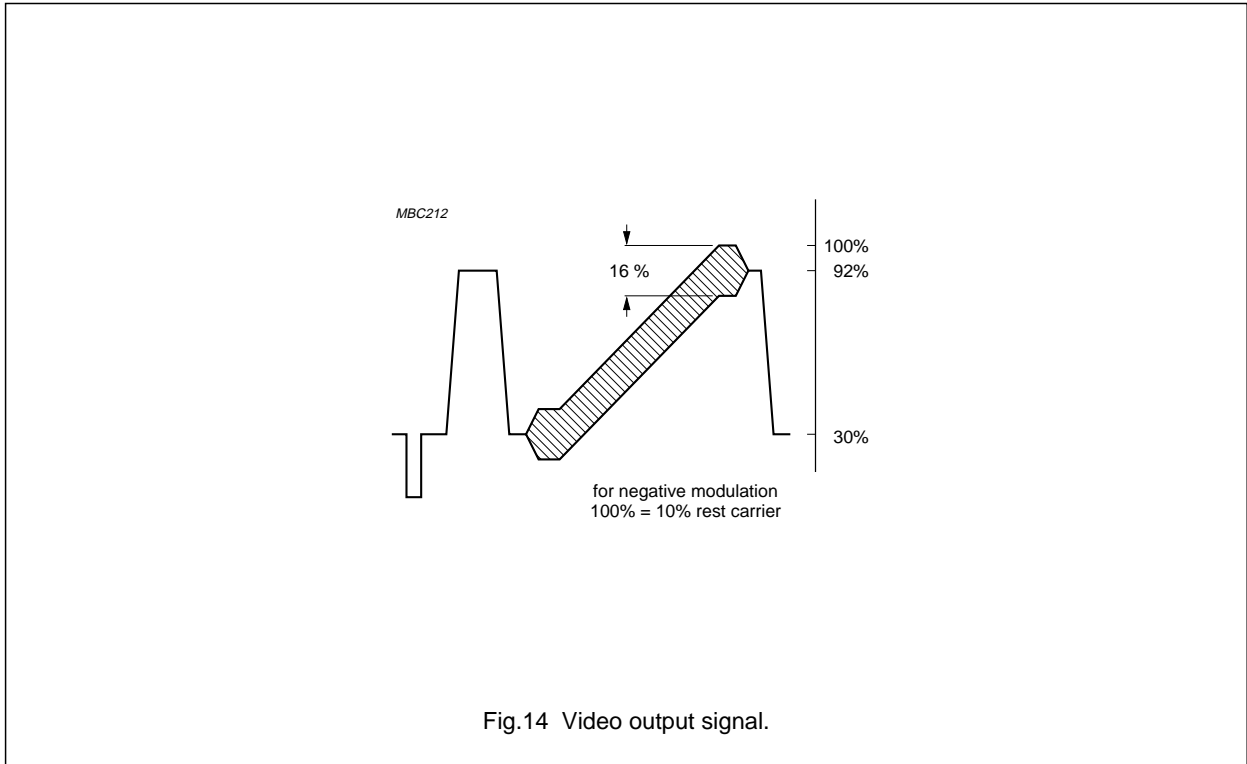

I²C-bus controlled economy PAL/NTSC
and NTSC TV-processors

TDA837x family

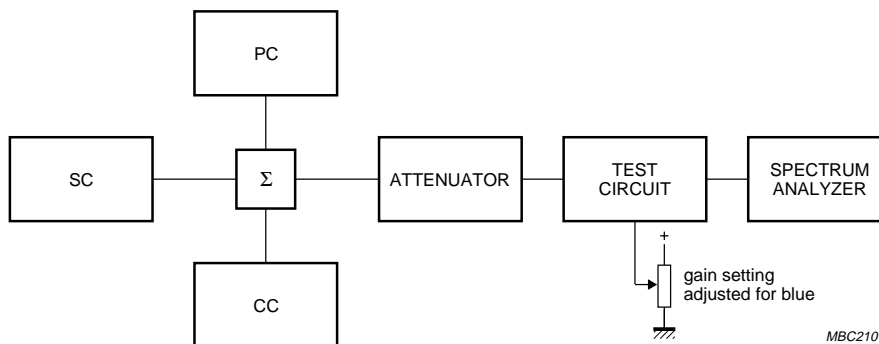
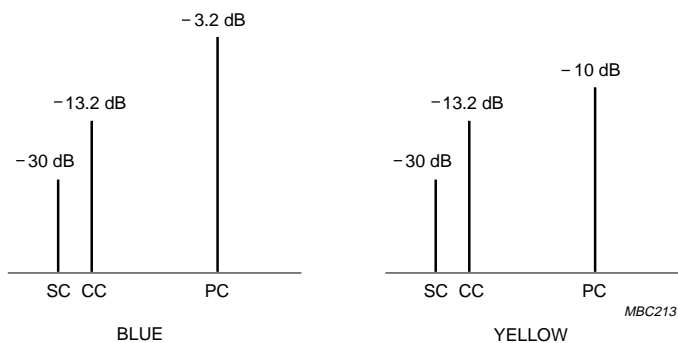

Input signal conditions: SC = Sound Carrier; CC = Colour Carrier; PC = Picture Carrier.
All amplitudes with respect to top sync level.

$$\text{Value at 0.92 or 1.1 MHz} = 20 \log \frac{V_O \text{ at 3.58 or 4.4 MHz}}{V_O \text{ at 0.92 or 1.1 MHz}} + 3.6 \text{ dB}$$

$$\text{Value at 2.66 or 3.3 MHz} = 20 \log \frac{V_O \text{ at 3.58 or 4.4 MHz}}{V_O \text{ at 2.66 or 3.3 MHz}}$$

Fig.16 Test set-up intermodulation.

I²C-bus controlled economy PAL/NTSC
and NTSC TV-processors

TDA837x family

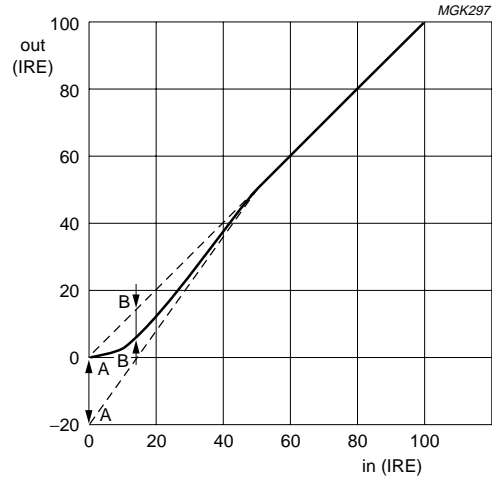

A-A = maximum black level shift; B-B = level shift at 15% of peak white.

Fig.17 Input/output relationship of the black level stretcher.

TEST AND APPLICATION INFORMATION

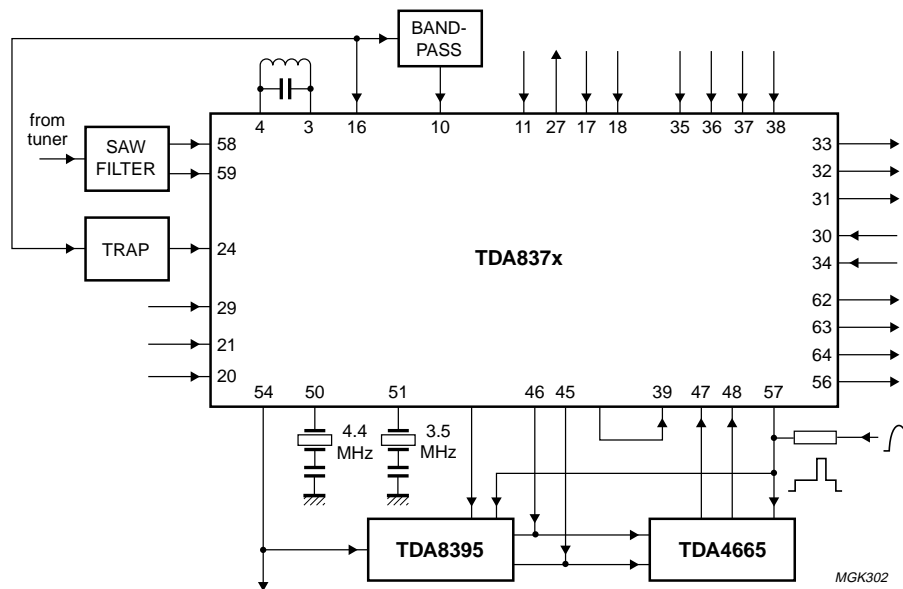

Fig.18 Simplified application diagram.

I²C-bus controlled economy PAL/NTSC and NTSC TV-processors

TDA837x family

East-West output stage

In order to obtain correct tracking of the vertical and horizontal EHT correction, the E-W output stage should be dimensioned as illustrated in Fig.19.

Resistor R_{ew} determines the gain of the E-W output stage. Resistor R_c determines the reference current for both the vertical sawtooth generator and the geometry processor. The preferred value of R_c is 39 k Ω which results in a reference current of 100 μ A ($V_{ref} = 3.9$ V).

The value of R_{ew} must be:
$$R_{ew} = R_c \times \frac{V_{scan}}{18 \times V_{ref}}$$

Example: With $V_{ref} = 3.9$ V; $R_c = 39$ k Ω and $V_{scan} = 120$ V then $R_{ew} \approx 68$ k Ω .

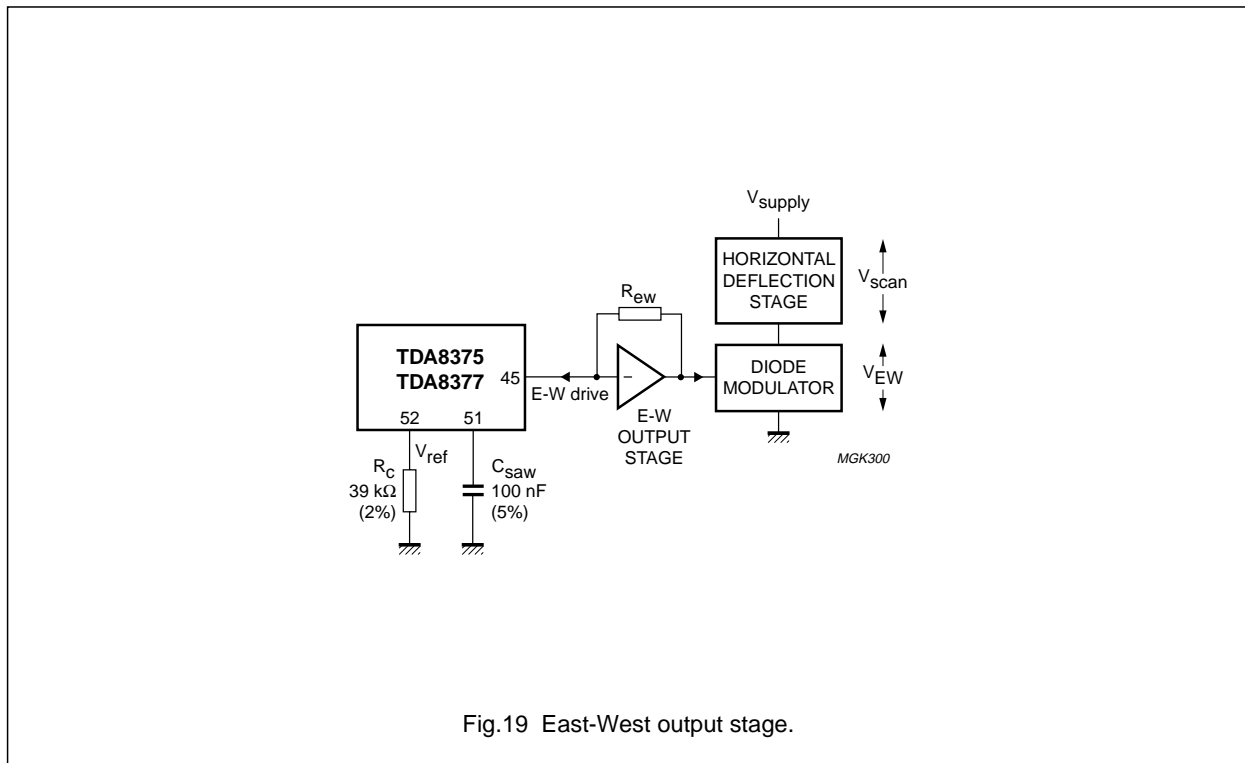

Control ranges of geometry control parameters

Typical case curves; $R_c = 39$ k Ω , $C_{SAW} = 100$ nF.

Figures 20 to 23 are valid for all types. Figures 24 to 27 are valid for TDA8375 and TDA8377.

I²C-bus controlled economy PAL/NTSC
and NTSC TV-processors

TDA837x family

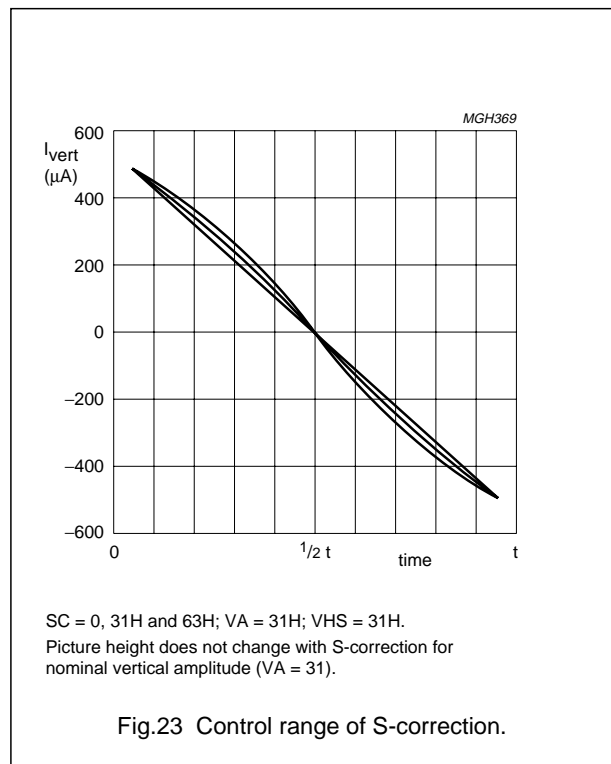
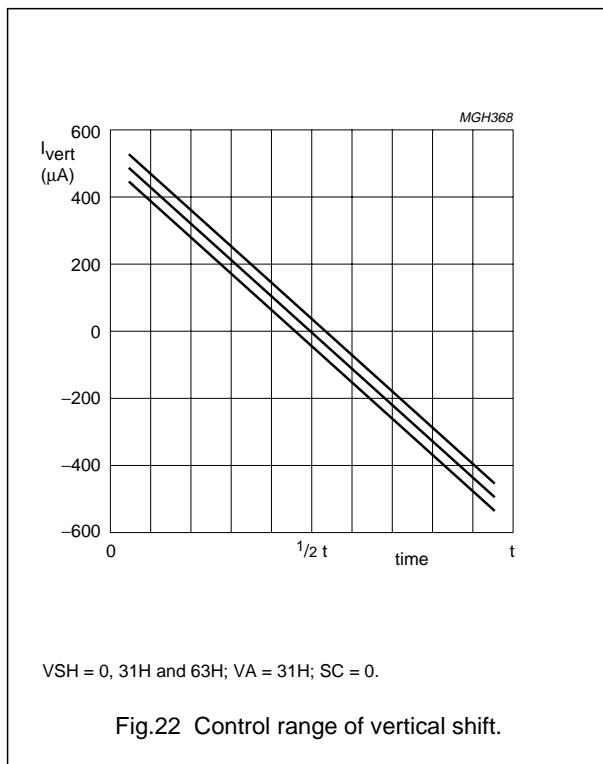
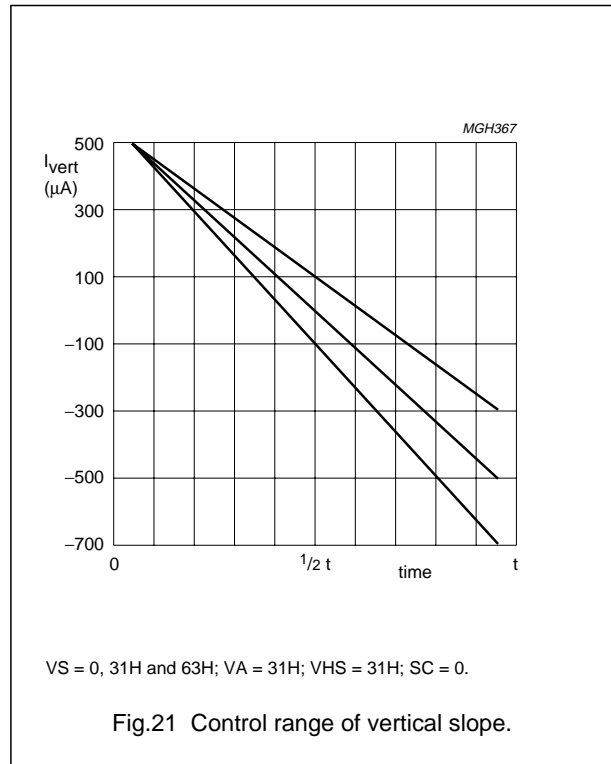
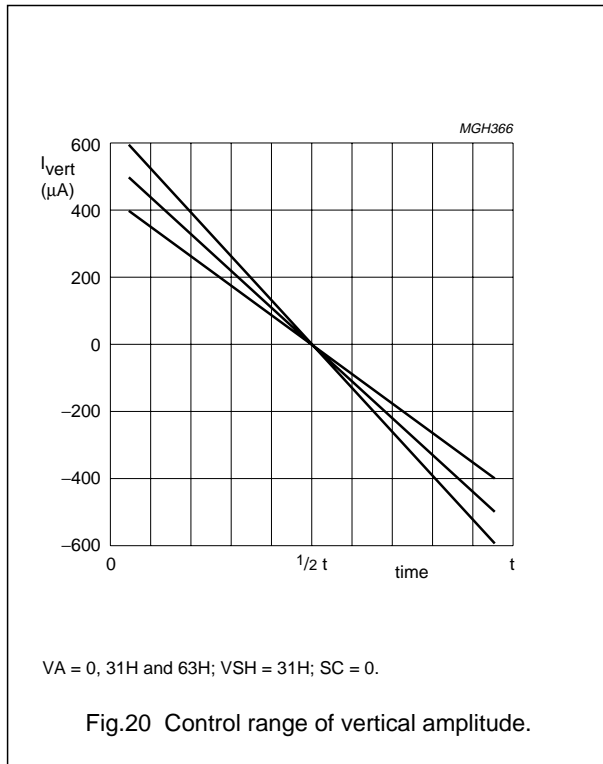

I²C-bus controlled economy PAL/NTSC
and NTSC TV-processors

TDA837x family

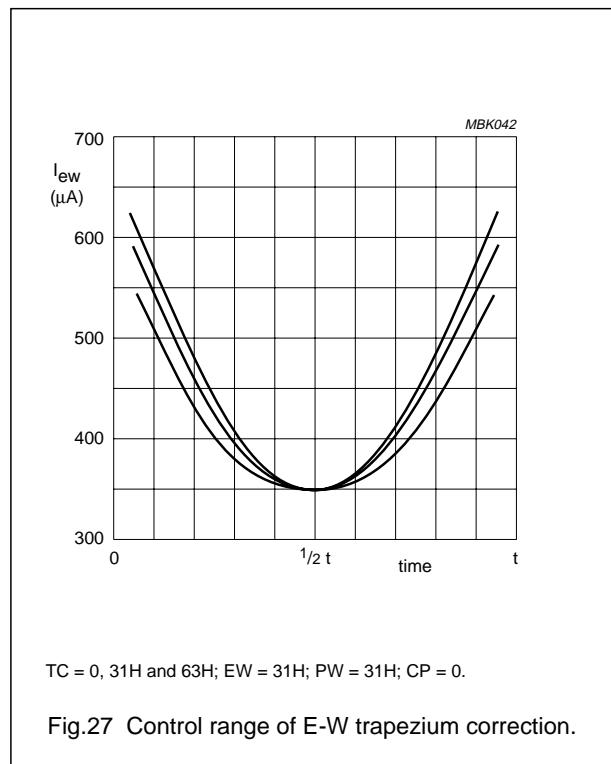
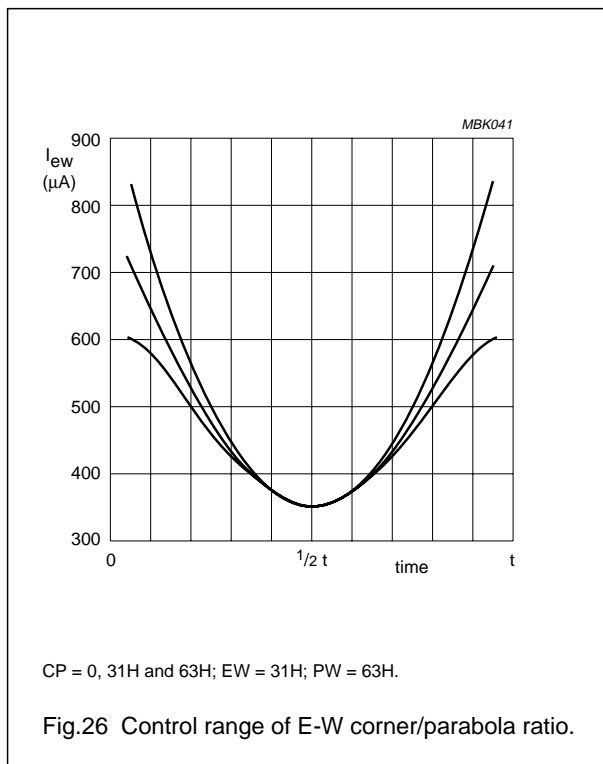
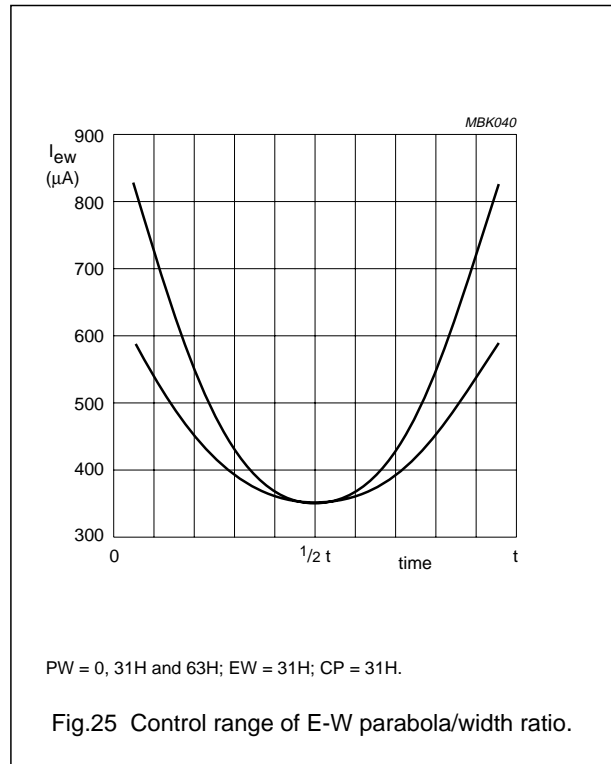
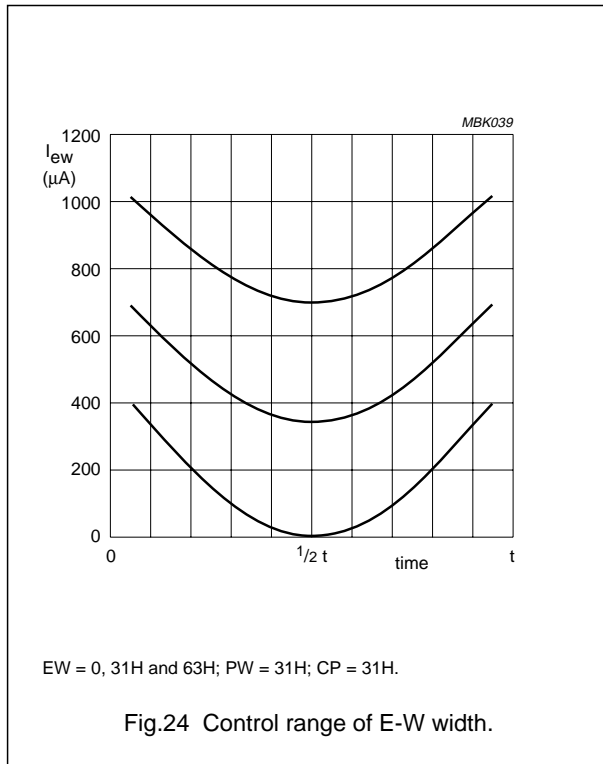

I²C-bus controlled economy PAL/NTSC and NTSC TV-processors

TDA837x family

Adjustment of geometry control parameters

The deflection processor of the TDA8373 and TDA8374 offers 5 control parameters for picture alignment:

- Vertical picture alignment
 - S-correction
 - vertical amplitude
 - vertical slope
 - vertical shift
 - Horizontal shift alignment.

The TDA8375, TDA8377, TDA8375A and TDA8377A offer in addition the following functions for horizontal alignment:

- E-W width
- E-W parabola/width
- E-W corner/parabola
- E-W trapezium correction.

It is important to notice that the ICs are designed for use with a DC-coupled vertical deflection stage. This is the reason why a vertical linearity alignment is not necessary (and, therefore, not available).

For a particular combination of picture tube type and vertical output stage and E-W output stage, it is determined which are the required values for the settings of S-correction. These parameters can be preset via the I²C-bus and do not need any additional adjustment. The remainder of the parameters are preset with the mid-value of their control range (i.e. 1FH), or with the values obtained by previous TV set adjustments.

The vertical shift control is intended for compensation of off-sets in the external vertical output stage or in the picture tube. It can be shown that without compensation these off-sets will result in a certain linearity error, especially with picture tubes that need large S-correction. The total linearity error is in 1st order approximation proportional to the value of the off-set and to the square of the S-correction needed. The necessity to use the vertical

shift alignment depends on the expected off-sets in vertical output stage and picture tube, on the required value of the S-correction and on the demands upon vertical linearity.

For adjustment of the vertical shift and vertical slope independent of each other, a special service blanking mode can be entered by setting the SBL bit HIGH. In this mode the RGB outputs are blanked during the second half of the picture. There are 2 different methods for alignment of the picture in vertical direction. Both methods make use of the service blanking mode.

The first method is recommended for picture tubes that have a marking for the middle of the screen. With the vertical shift control the last line of the visible picture is positioned exactly in the middle of the screen. After this adjustment the vertical shift should not be changed.

The top of the picture is placed by adjusting the vertical amplitude and the bottom by adjusting the vertical slope.

The second method is recommended for picture tubes that have no marking for the middle of the screen. For this method a video signal is required in which the middle of the picture is indicated (e.g. the white line in the circle test pattern). With the vertical slope control the beginning of the blanking is positioned exactly on the middle of the picture. Then the top and bottom of the picture are placed symmetrically with respect to the middle of the screen by adjustment of the vertical amplitude and vertical shift. After this adjustment the vertical shift has the correct setting and should not be changed.

If the vertical shift alignment is not required VSH should be set to its mid-value (i.e. $VSH = 1FH$). The top of the picture is then placed by adjusting the vertical amplitude and the bottom by adjusting the vertical slope. After the vertical picture alignment the picture is positioned in the horizontal direction by adjusting the horizontal shift.

To obtain the full range of the vertical zoom function with the TDA8375 and TDA8377 the adjustment of the vertical geometry should be carried out at a nominal setting of the zoom DAC at position 19H.

I²C-bus controlled economy PAL/NTSC
and NTSC TV-processors

TDA837x family

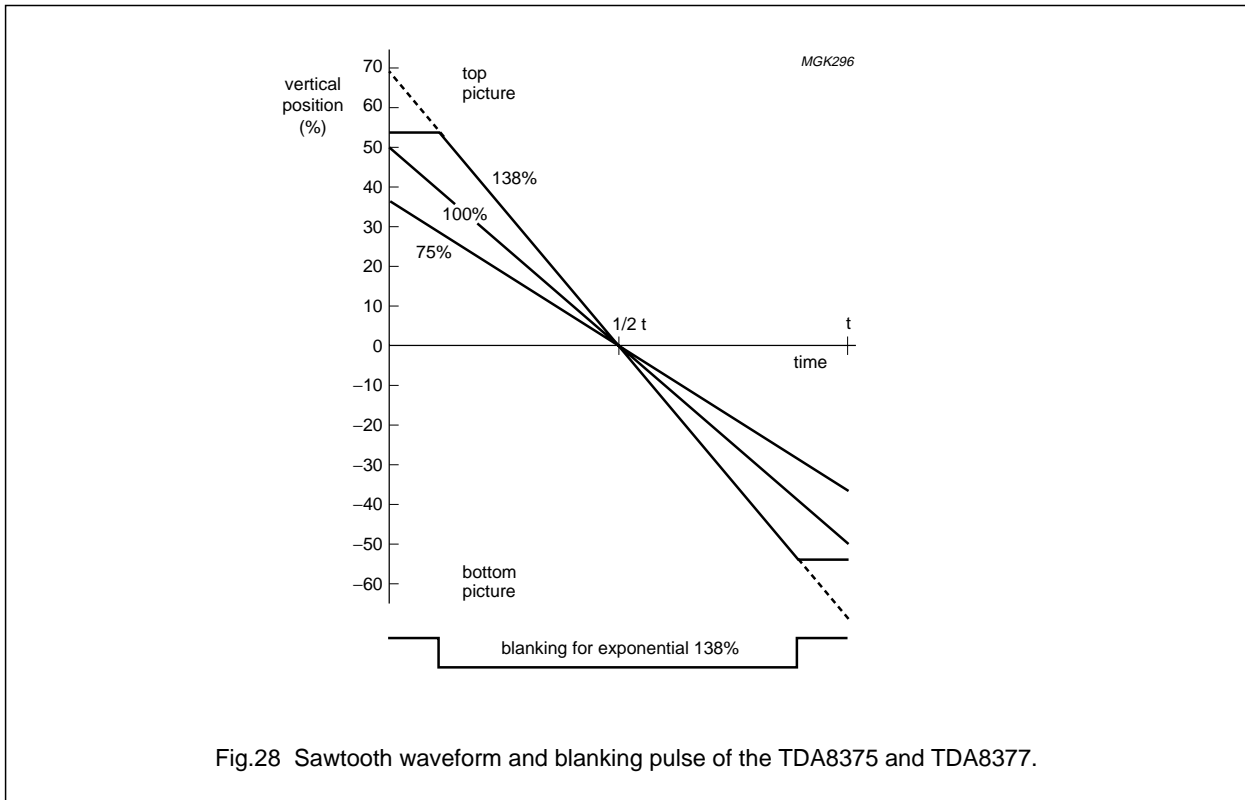
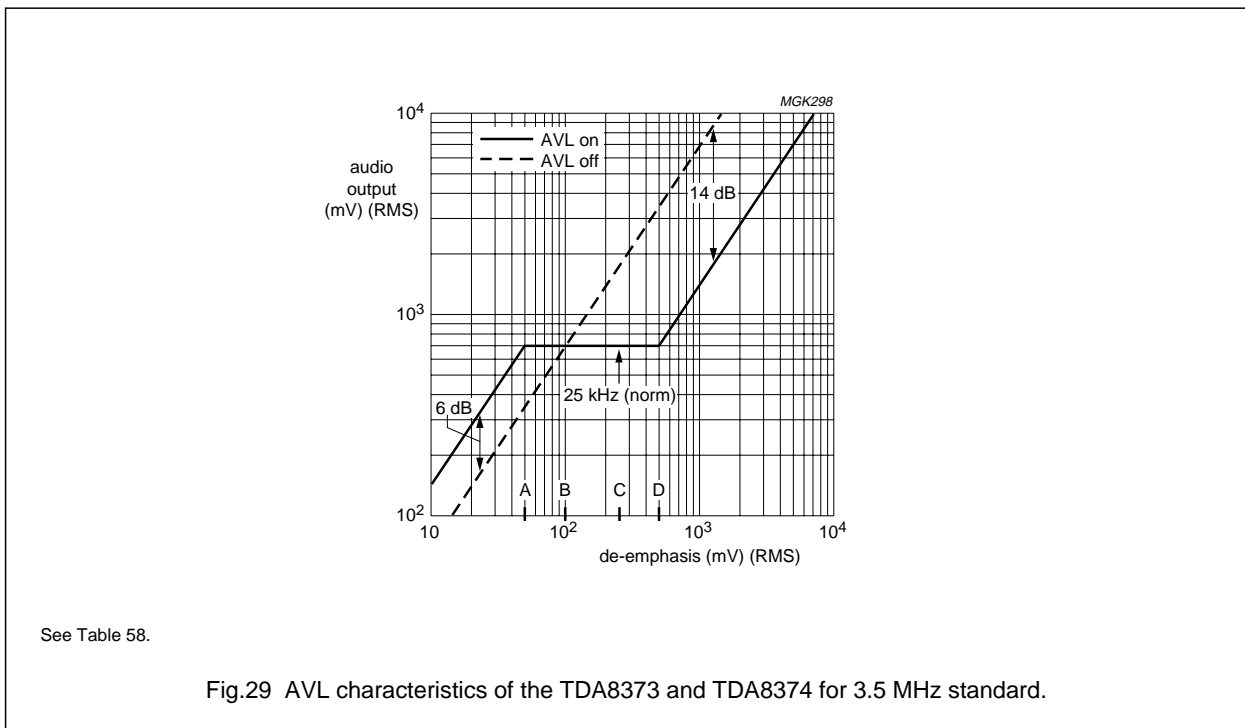

Fig.28 Sawtooth waveform and blanking pulse of the TDA8375 and TDA8377.



See Table 58.

Fig.29 AVL characteristics of the TDA8373 and TDA8374 for 3.5 MHz standard.

I²C-bus controlled economy PAL/NTSC
and NTSC TV-processors

TDA837x family

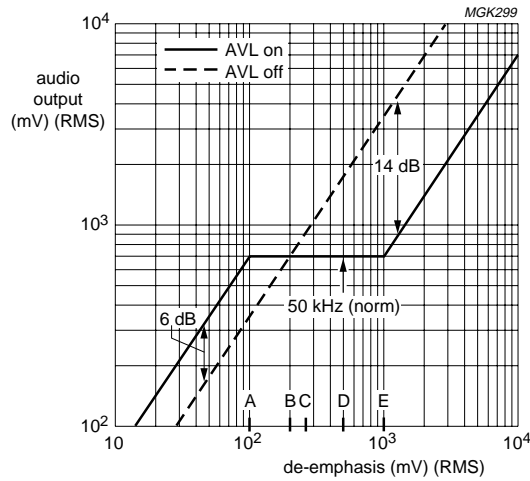

See Table 59.

Fig.30 AVL characteristics of the TDA8374 for 4.4 MHz standard.

Table 58 Explanation to Fig.29

A	B	C	D	DESCRIPTION
50	100	250	500	de-emphasis pin 55 [mV (RMS)]
5	10	25	50	FM swing (kHz)
50	100	250	500	AVL input [mV (RMS)]
100	200	500	1000	external input [mV (RMS)]

Table 59 Explanation to Fig.30

A	B	C	D	DESCRIPTION
100	200	250	1000	de-emphasis pin 55 [mV (RMS)]
10	20	25	100	FM swing (kHz)
50	100	125	500	AVL input [mV (RMS)]
100	200	250	1000	external input [mV (RMS)]

I²C-bus controlled economy PAL/NTSC
and NTSC TV-processors

TDA837x family

INTERNAL PIN CONFIGURATION

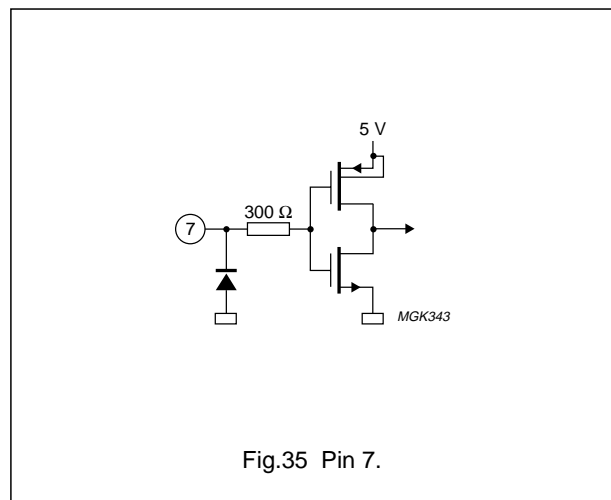
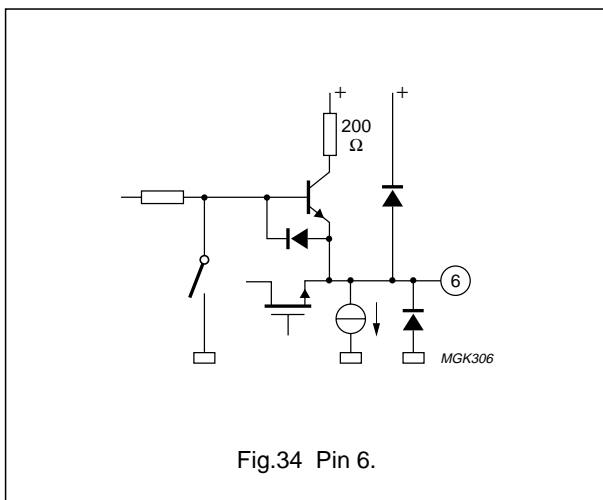
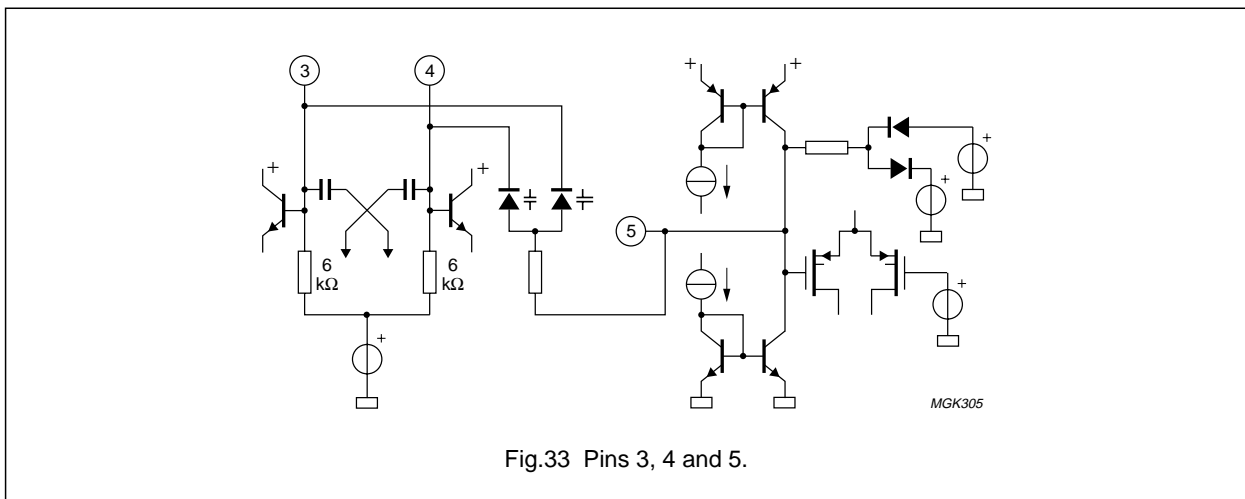
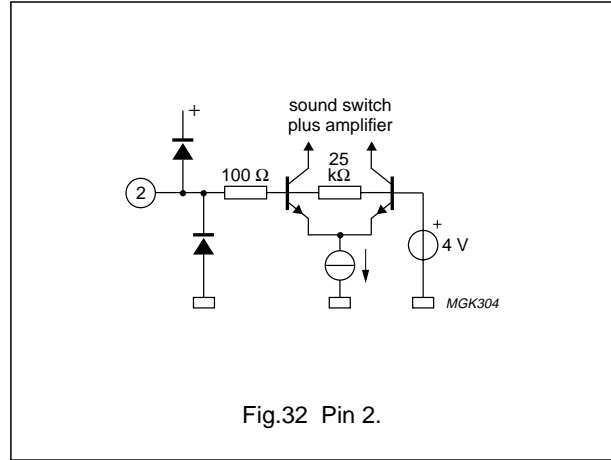
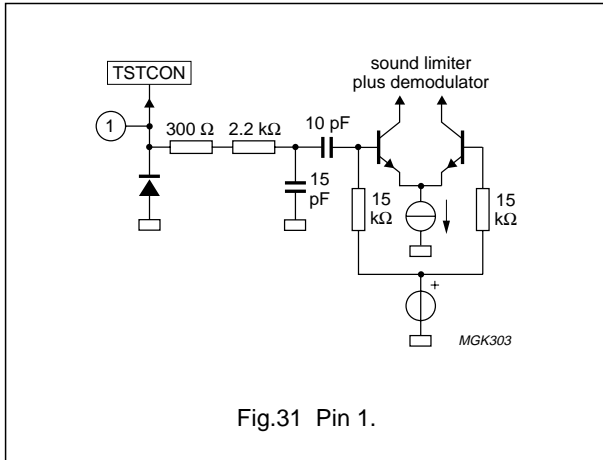

I²C-bus controlled economy PAL/NTSC
and NTSC TV-processors

TDA837x family

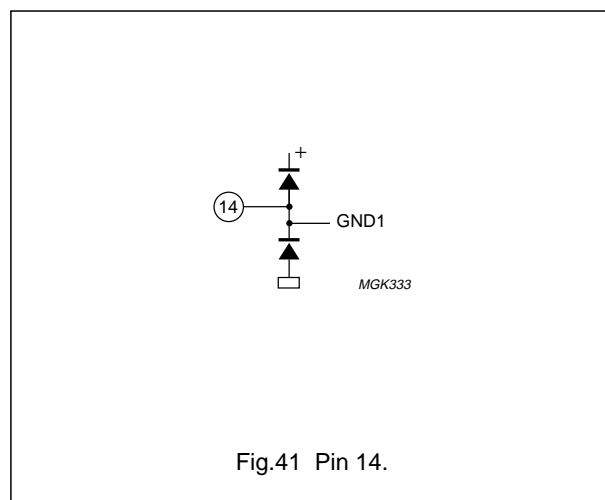
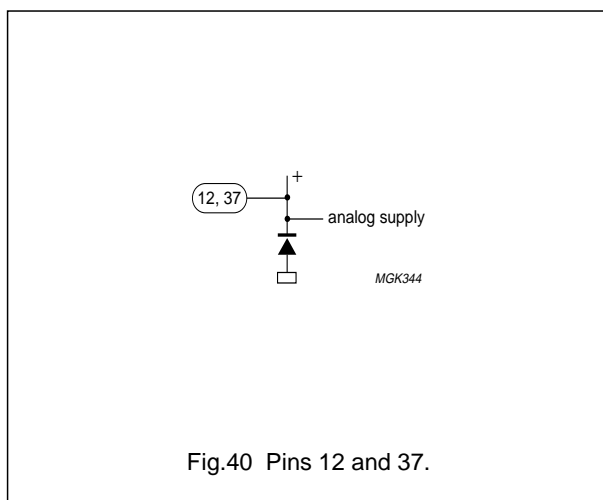
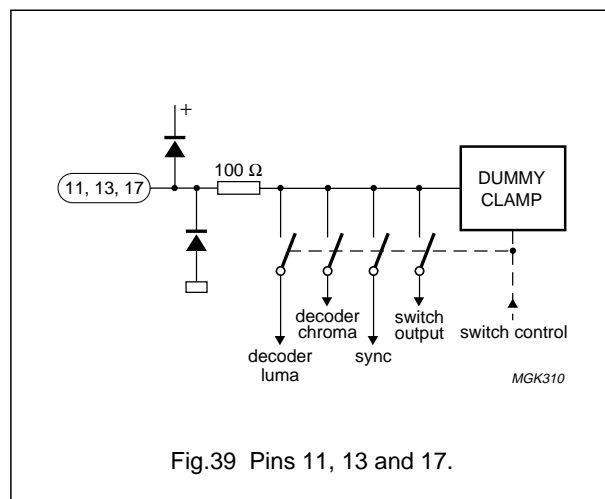
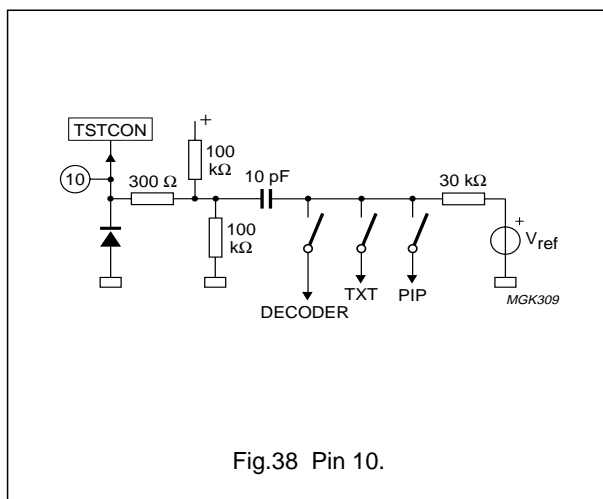
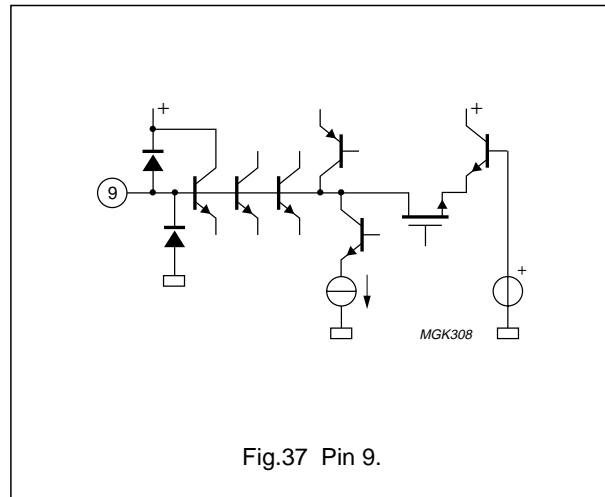
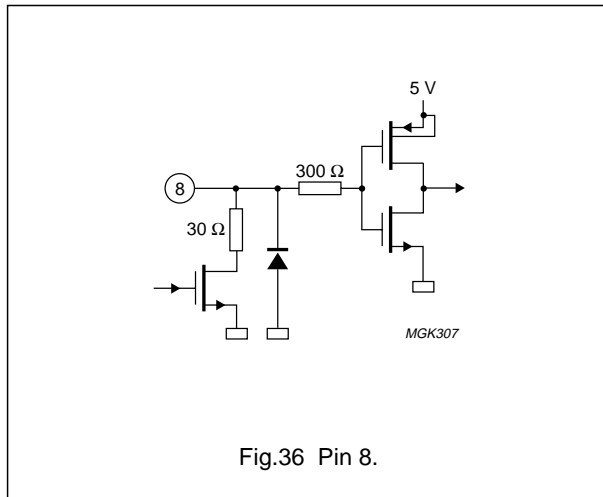

I²C-bus controlled economy PAL/NTSC
and NTSC TV-processors

TDA837x family

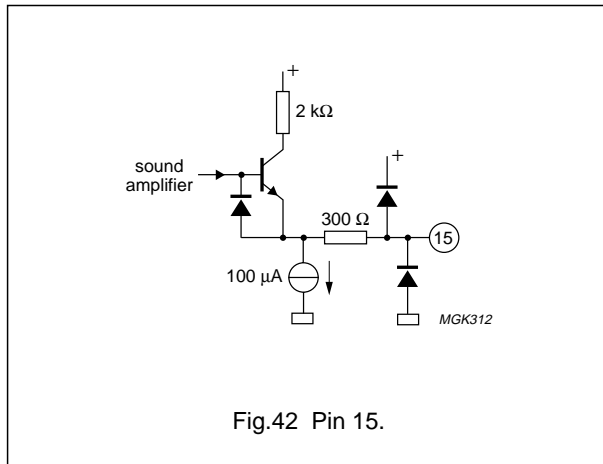

Fig.42 Pin 15.

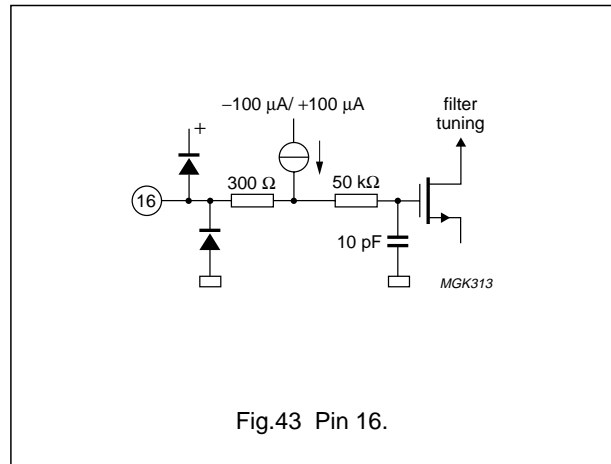

Fig.43 Pin 16.

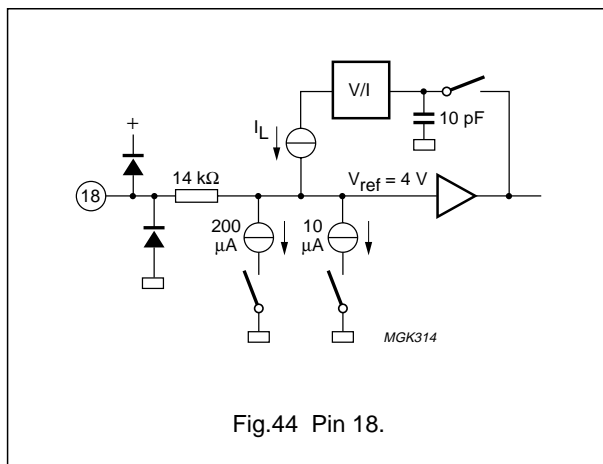

Fig.44 Pin 18.

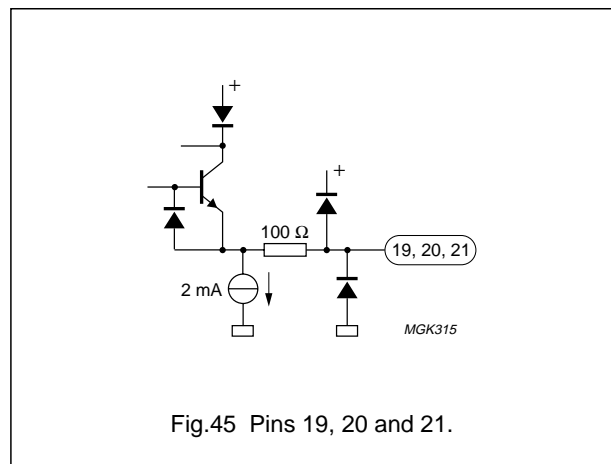

Fig.45 Pins 19, 20 and 21.

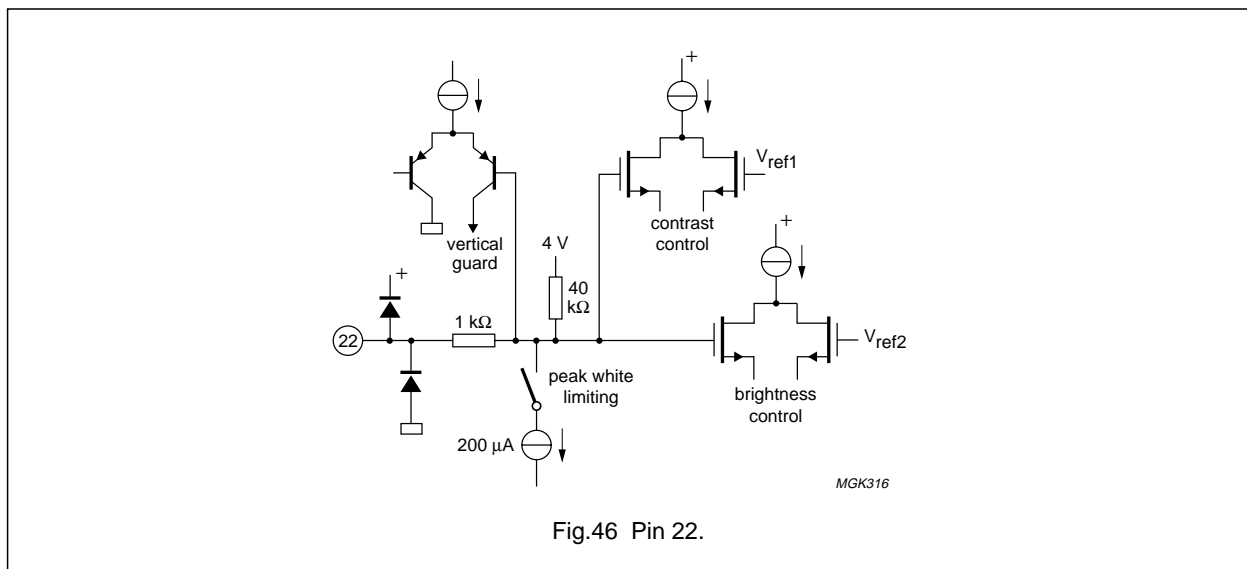
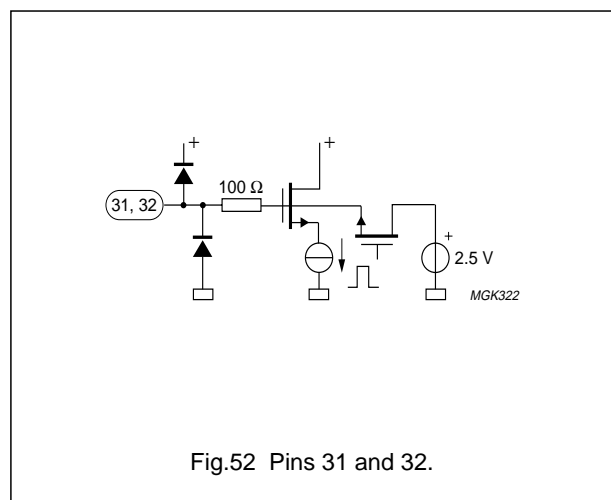
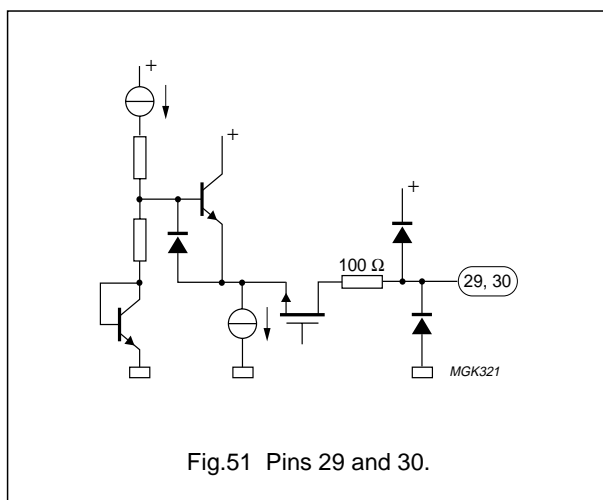
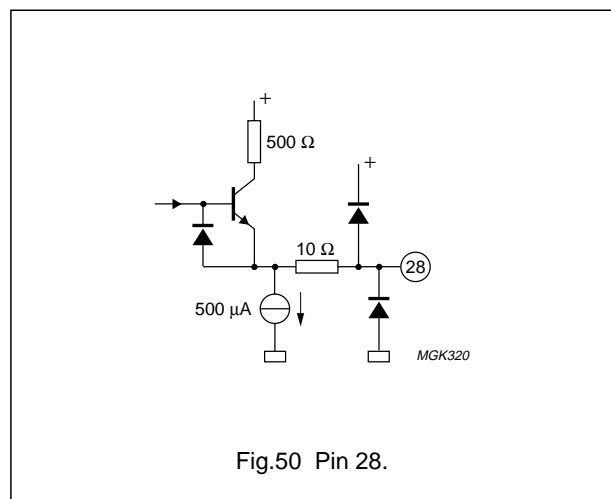
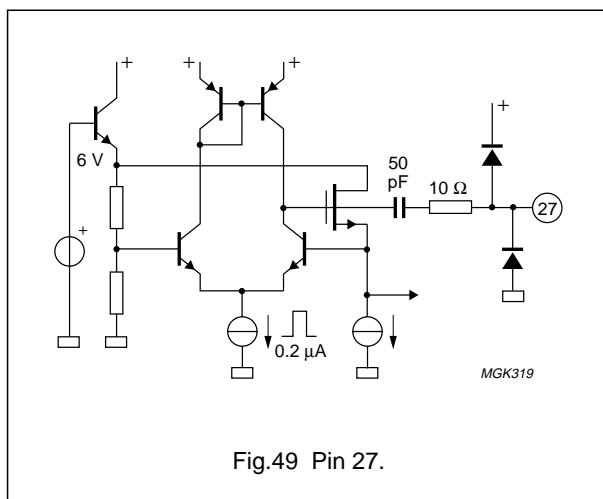
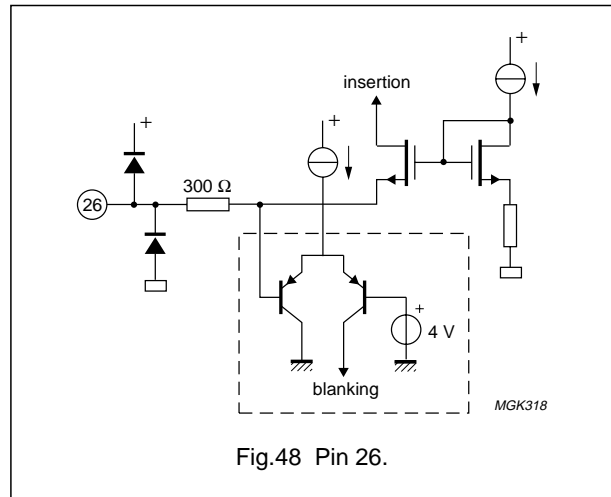
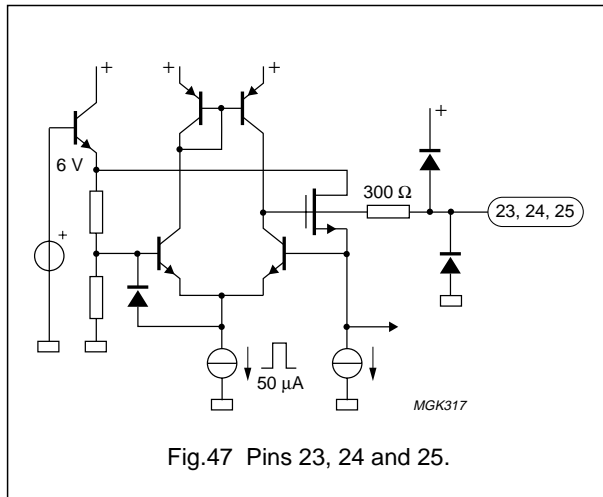

Fig.46 Pin 22.

I²C-bus controlled economy PAL/NTSC
and NTSC TV-processors

TDA837x family



I²C-bus controlled economy PAL/NTSC and NTSC TV-processors

TDA837x family

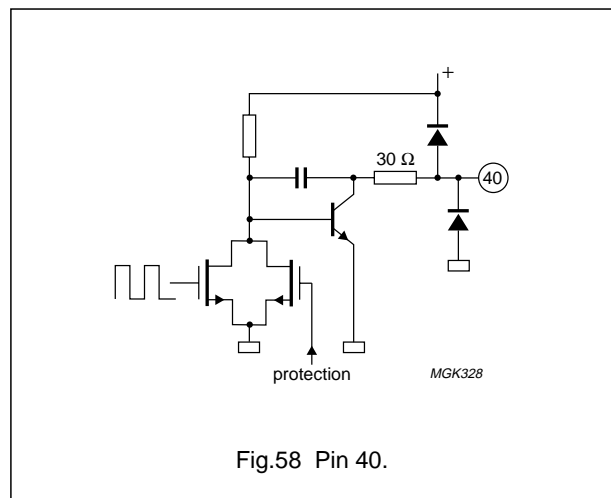
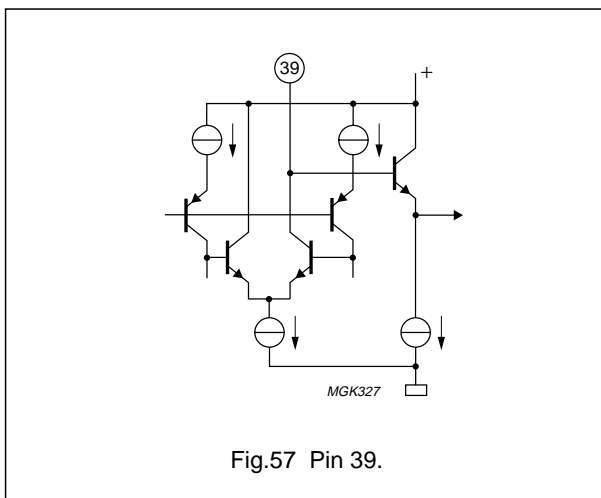
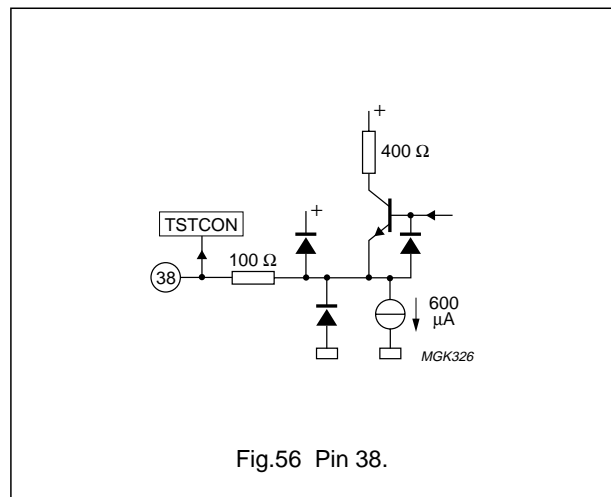
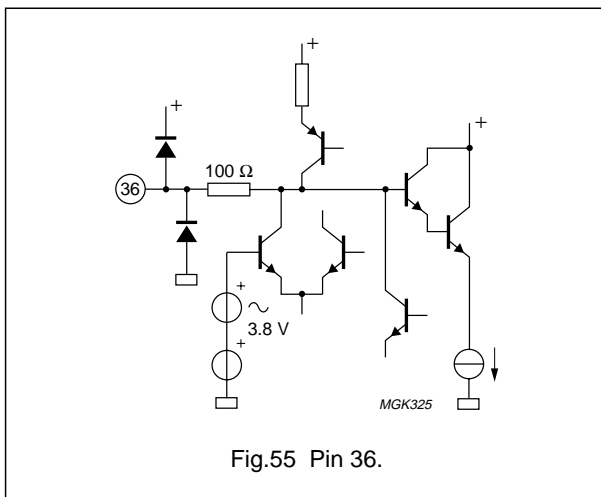
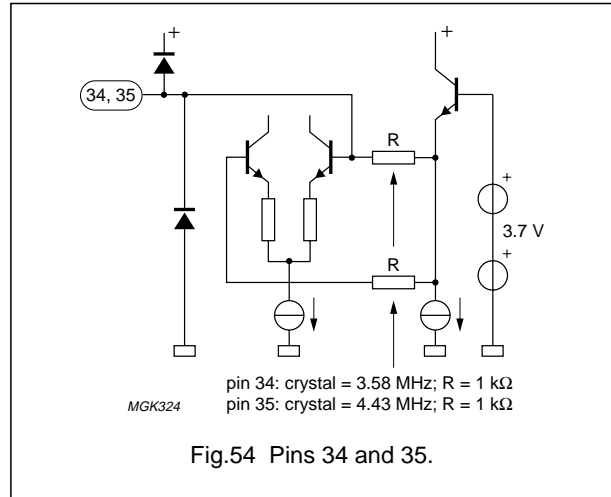
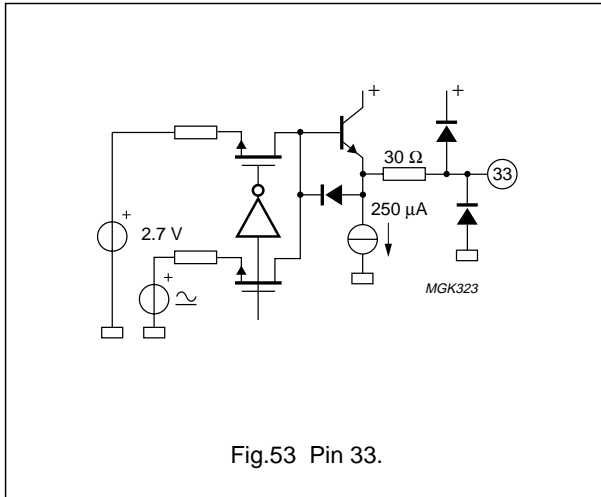

I²C-bus controlled economy PAL/NTSC
and NTSC TV-processors

TDA837x family

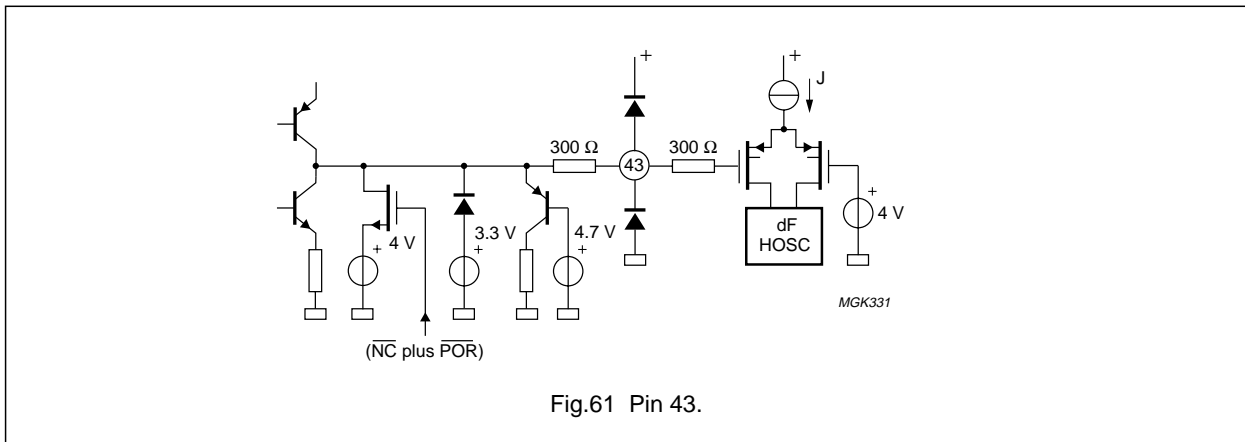
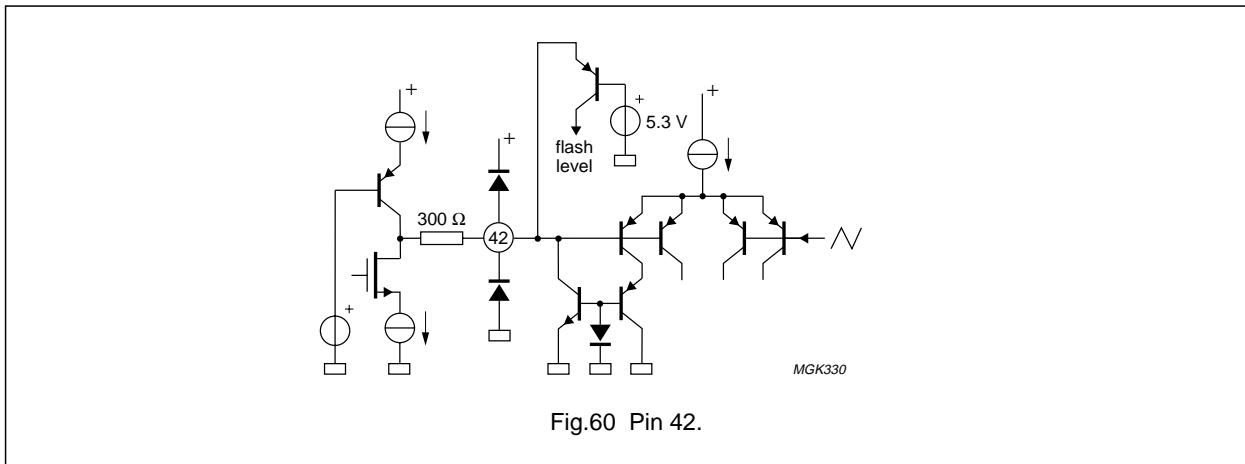
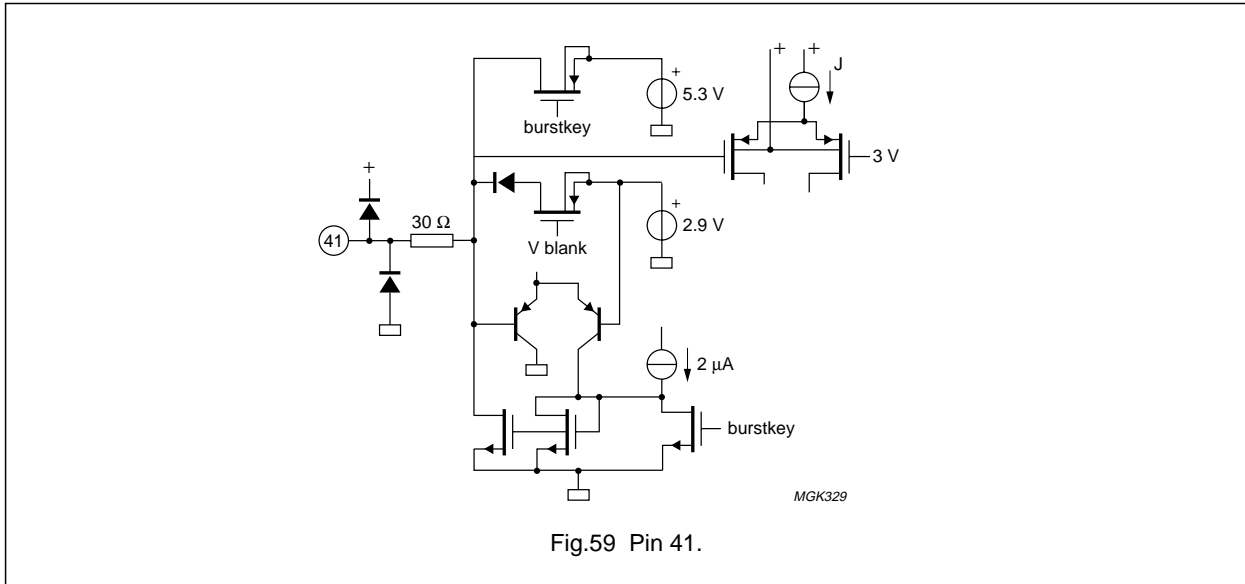

I²C-bus controlled economy PAL/NTSC
and NTSC TV-processors

TDA837x family

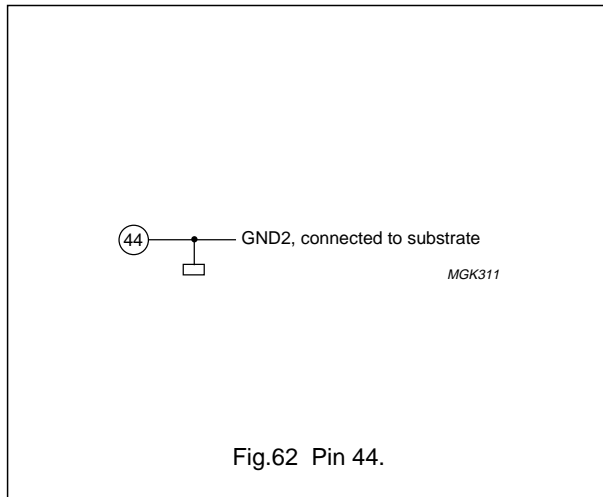

Fig.62 Pin 44.

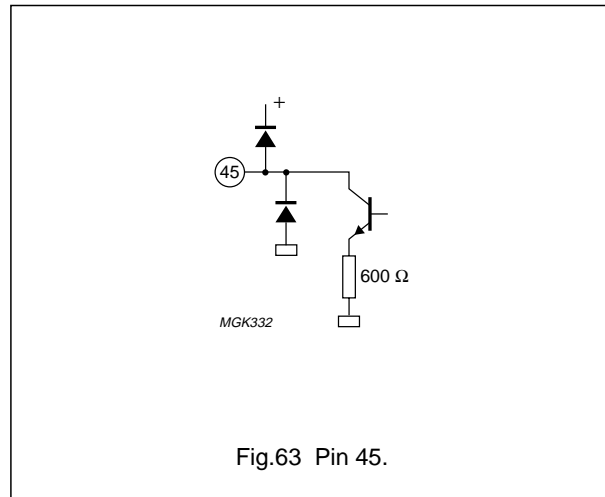

Fig.63 Pin 45.

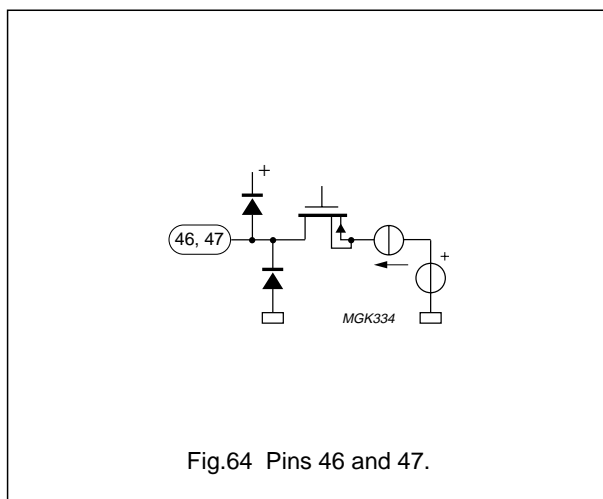

Fig.64 Pins 46 and 47.

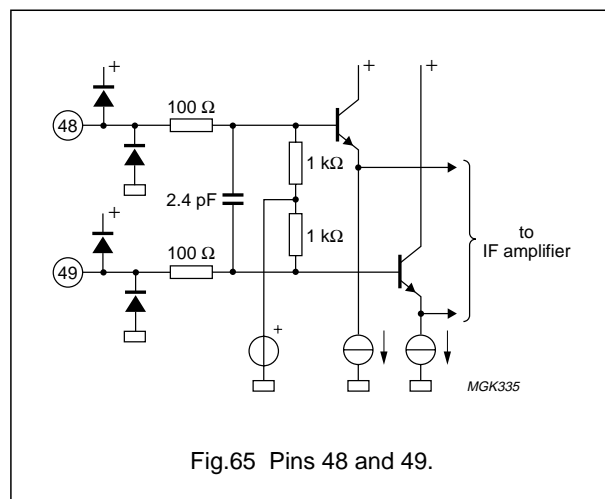

Fig.65 Pins 48 and 49.

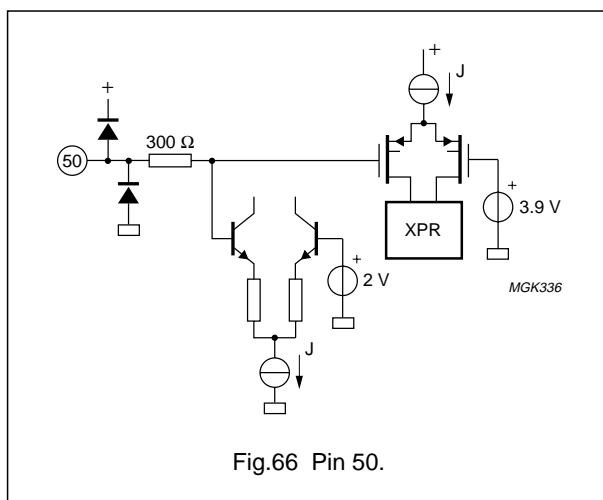

Fig.66 Pin 50.

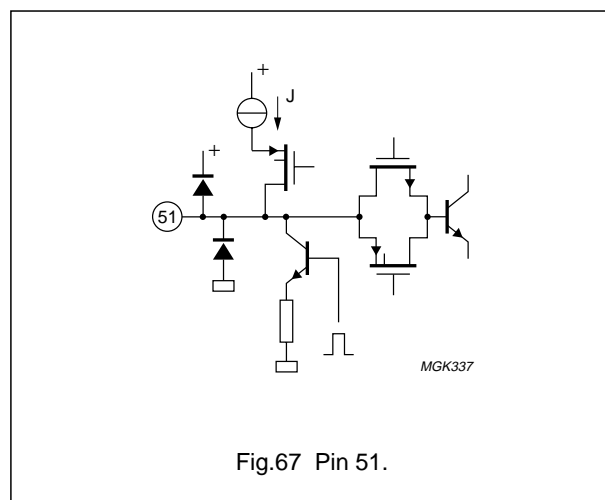

Fig.67 Pin 51.

I²C-bus controlled economy PAL/NTSC
and NTSC TV-processors

TDA837x family

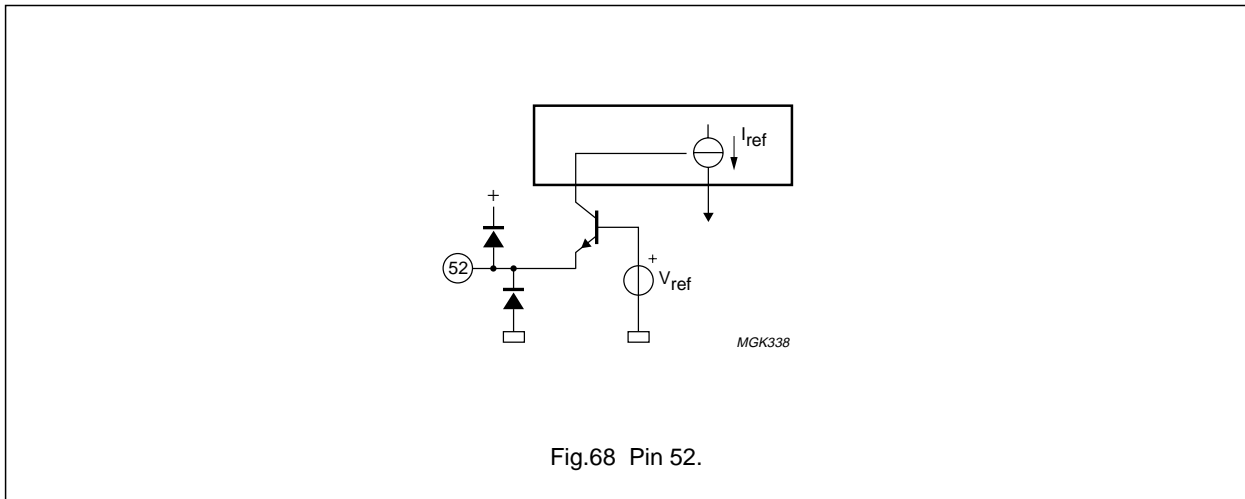

Fig.68 Pin 52.

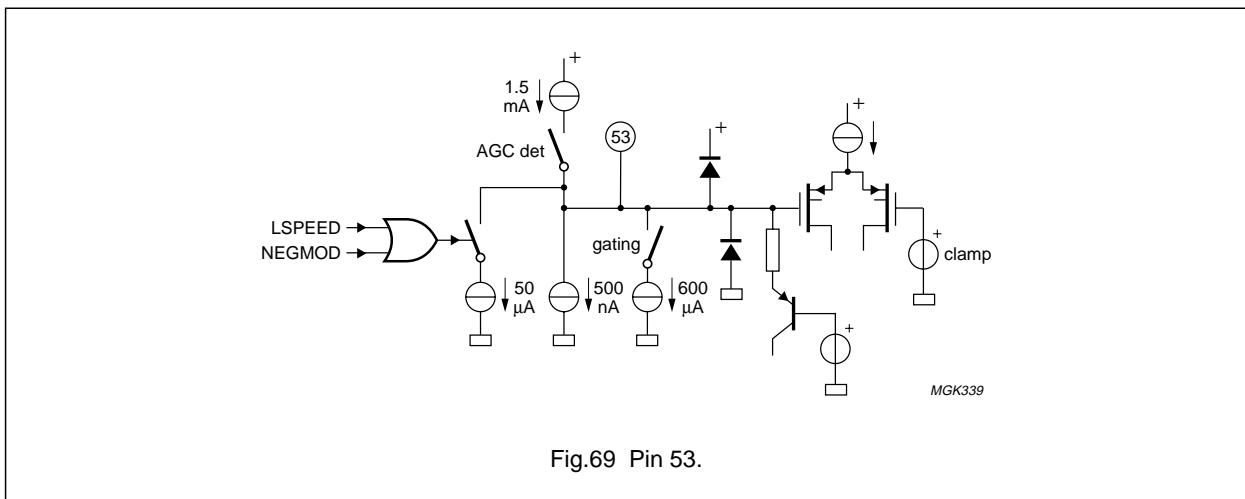

Fig.69 Pin 53.

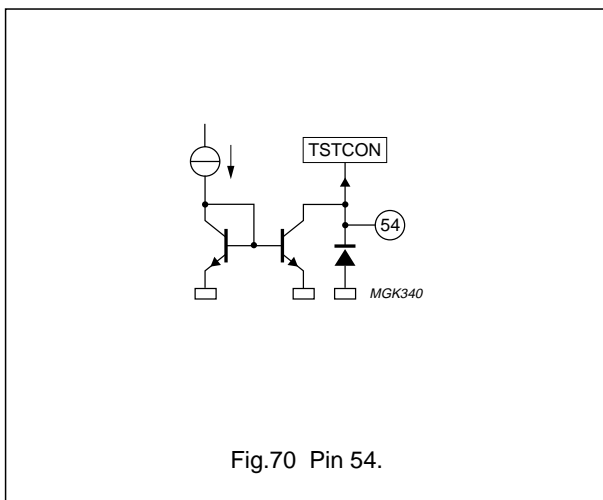

Fig.70 Pin 54.

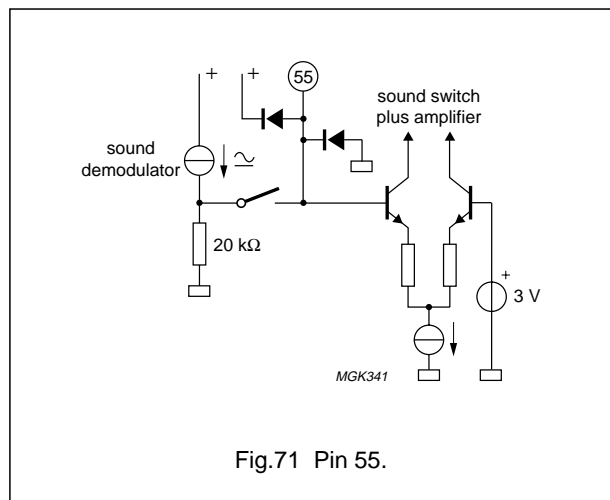

Fig.71 Pin 55.

I²C-bus controlled economy PAL/NTSC
and NTSC TV-processors

TDA837x family

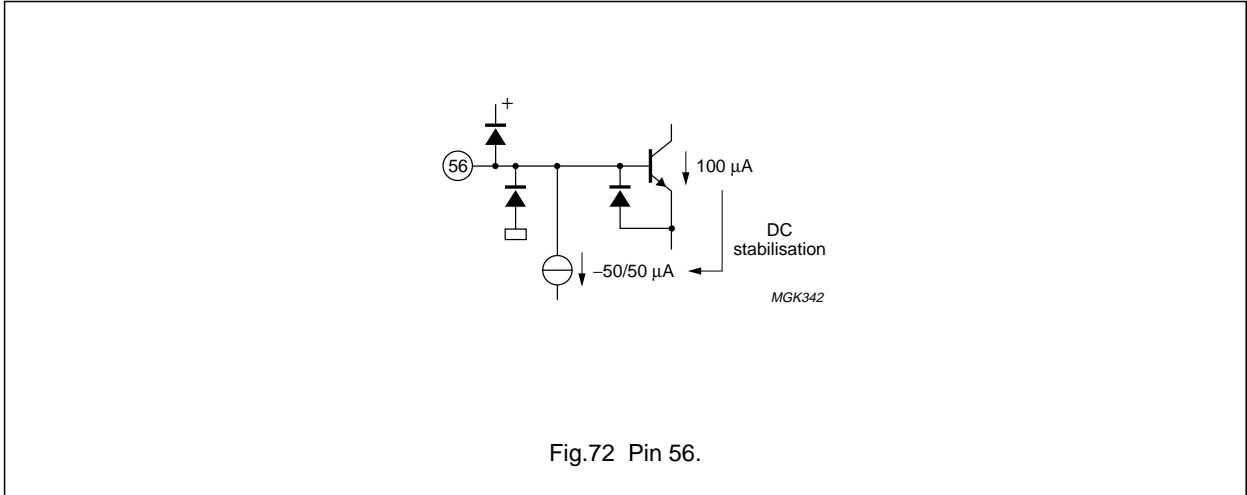

Fig.72 Pin 56.

I²C-bus controlled economy PAL/NTSC
and NTSC TV-processors

TDA837x family

PACKAGE OUTLINES

QFP64: plastic quad flat package;
64 leads (lead length 1.95 mm); body 14 x 20 x 2.7 mm; high stand-off height

SOT319-1

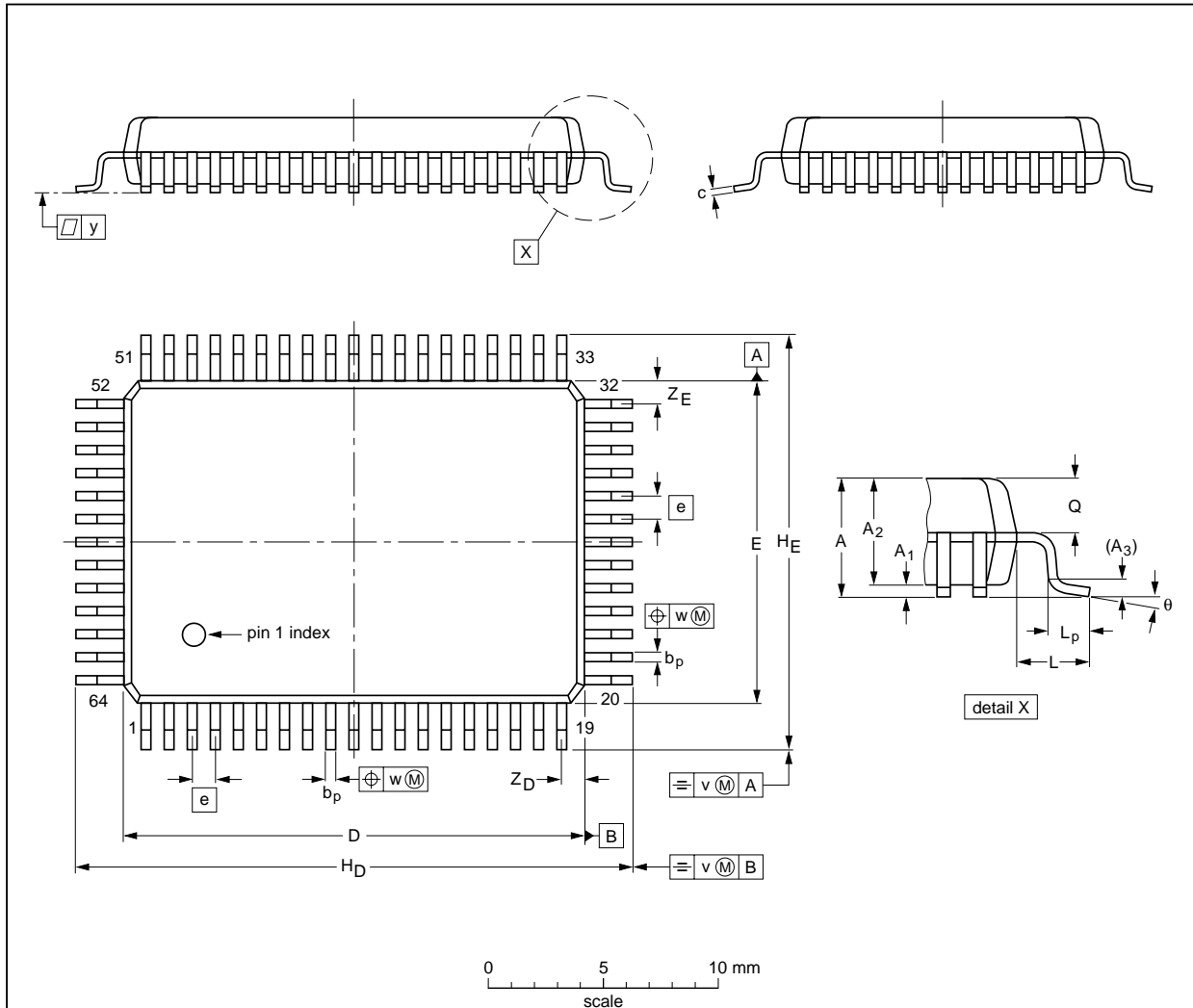

DIMENSIONS (mm are the original dimensions)

UNIT	A max.	A ₁	A ₂	A ₃	b _p	c	D ⁽¹⁾	E ⁽¹⁾	e	H _D	H _E	L	L _p	Q	v	w	y	Z _D ⁽¹⁾	Z _E ⁽¹⁾	θ
mm	3.3	0.36 0.10	2.87 2.57	0.25	0.50 0.35	0.25 0.13	20.1 19.9	14.1 13.9	1	24.2 23.6	18.2 17.6	1.95	1.0 0.6	1.43 1.23	0.2	0.2	0.1	1.2 0.8	1.2 0.8	7° 0°

Note

1. Plastic or metal protrusions of 0.25 mm maximum per side are not included.

OUTLINE VERSION	REFERENCES				EUROPEAN PROJECTION	ISSUE DATE
	IEC	JEDEC	EIAJ			
SOT319-1						92-11-17 95-02-04

I²C-bus controlled economy PAL/NTSC
and NTSC TV-processors

TDA837x family

SDIP56: plastic shrink dual in-line package; 56 leads (600 mil)

SOT400-1

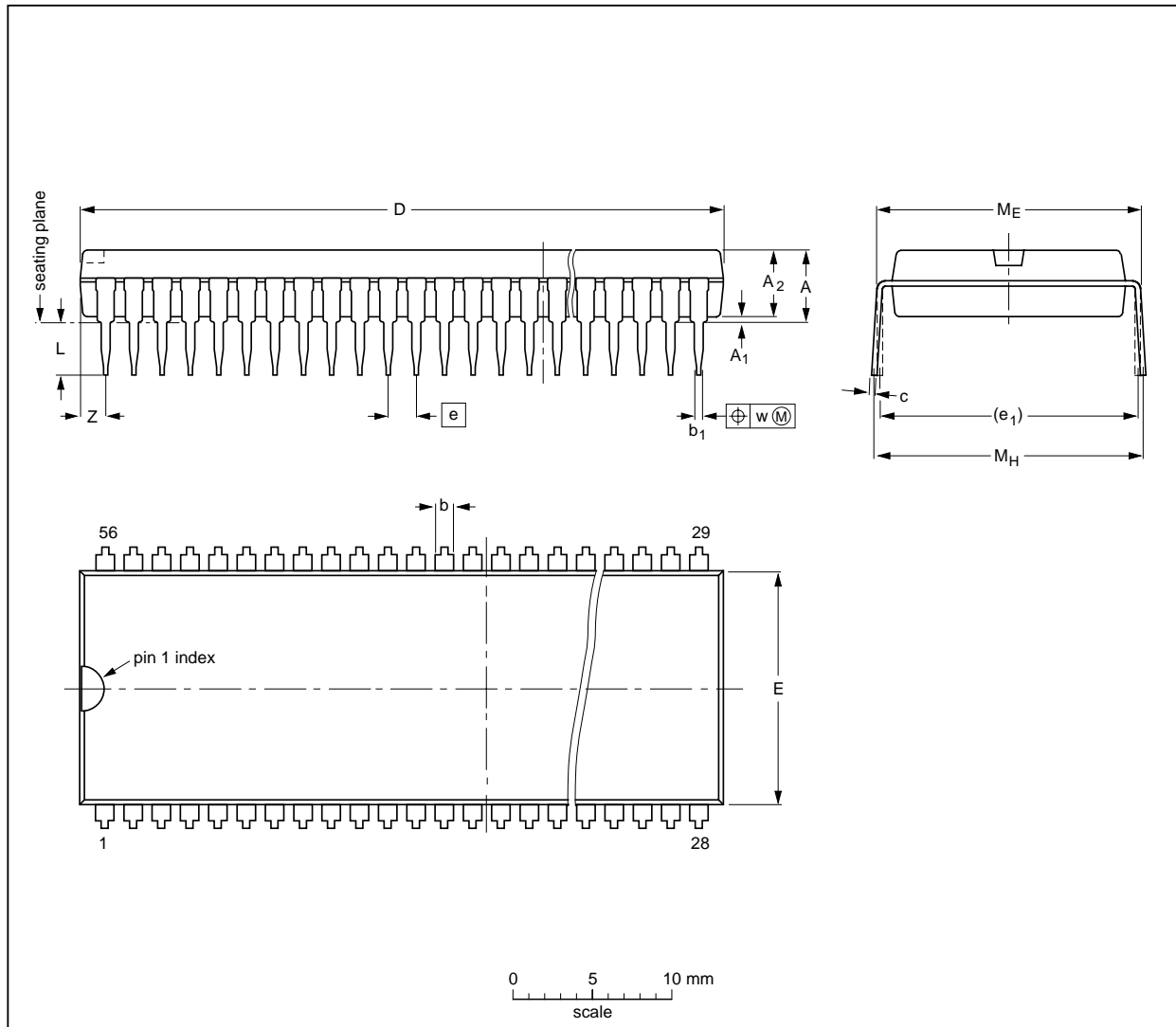

DIMENSIONS (mm are the original dimensions)

UNIT	A max.	A ₁ min.	A ₂ max.	b	b ₁	c	D ⁽¹⁾	E ⁽¹⁾	e	e ₁	L	M _E	M _H	w	Z ⁽¹⁾ max.
mm	5.08	0.51	4.0	1.3 0.8	0.53 0.40	0.32 0.23	52.4 51.6	14.0 13.6	1.778	15.24	3.2 2.8	15.80 15.24	17.15 15.90	0.18	2.3

Note

1. Plastic or metal protrusions of 0.25 mm maximum per side are not included.

OUTLINE VERSION	REFERENCES				EUROPEAN PROJECTION	ISSUE DATE
	IEC	JEDEC	EIAJ			
SOT400-1						95-12-06

I²C-bus controlled economy PAL/NTSC and NTSC TV-processors

TDA837x family

SOLDERING

Introduction

There is no soldering method that is ideal for all IC packages. Wave soldering is often preferred when through-hole and surface mounted components are mixed on one printed-circuit board. However, wave soldering is not always suitable for surface mounted ICs, or for printed-circuits with high population densities. In these situations reflow soldering is often used.

This text gives a very brief insight to a complex technology. A more in-depth account of soldering ICs can be found in our *"IC Package Databook"* (order code 9398 652 90011).

SDIP

SOLDERING BY DIPPING OR BY WAVE

The maximum permissible temperature of the solder is 260 °C; solder at this temperature must not be in contact with the joint for more than 5 seconds. The total contact time of successive solder waves must not exceed 5 seconds.

The device may be mounted up to the seating plane, but the temperature of the plastic body must not exceed the specified maximum storage temperature ($T_{stg\ max}$). If the printed-circuit board has been pre-heated, forced cooling may be necessary immediately after soldering to keep the temperature within the permissible limit.

REPAIRING SOLDERED JOINTS

Apply a low voltage soldering iron (less than 24 V) to the lead(s) of the package, below the seating plane or not more than 2 mm above it. If the temperature of the soldering iron bit is less than 300 °C it may remain in contact for up to 10 seconds. If the bit temperature is between 300 and 400 °C, contact may be up to 5 seconds.

QFP

REFLOW SOLDERING

Reflow soldering techniques are suitable for all QFP packages.

The choice of heating method may be influenced by larger plastic QFP packages (44 leads, or more). If infrared or vapour phase heating is used and the large packages are not absolutely dry (less than 0.1% moisture content by weight), vaporization of the small amount of moisture in them can cause cracking of the plastic body. For more information, refer to the Drypack chapter in our *"Quality Reference Handbook"* (order code 9397 750 00192).

Reflow soldering requires solder paste (a suspension of fine solder particles, flux and binding agent) to be applied to the printed-circuit board by screen printing, stencilling or pressure-syringe dispensing before package placement.

Several techniques exist for reflowing; for example, thermal conduction by heated belt. Dwell times vary from 50 to 300 seconds depending on heating method. Typical reflow temperatures range from 215 to 250 °C.

Preheating is necessary to dry the paste and evaporate the binding agent. Preheat for 45 minutes at 45 °C.

WAVE SOLDERING

Wave soldering is **not** recommended for QFP packages. This is because of the likelihood of solder bridging due to closely-spaced leads and the possibility of incomplete solder penetration in multi-lead devices.

If wave soldering cannot be avoided, the following conditions must be observed:

- **A double-wave (a turbulent wave with high upward pressure followed by a smooth laminar wave) soldering technique should be used.**
- **The footprint must be at an angle of 45° to the board direction and must incorporate solder thieves downstream and at the side corners.**

Even with these conditions, do not consider wave soldering the following packages: QFP52 (SOT379-1), QFP100 (SOT317-1), QFP100 (SOT317-2), QFP100 (SOT382-1) or QFP160 (SOT322-1).

During placement and before soldering, the package must be fixed with a droplet of adhesive. The adhesive can be applied by screen printing, pin transfer or syringe dispensing. The package can be soldered after the adhesive is cured. Maximum permissible solder temperature is 260 °C, and maximum duration of package immersion in solder is 10 seconds, if cooled to less than 150 °C within 6 seconds. Typical dwell time is 4 seconds at 250 °C.

A mildly-activated flux will eliminate the need for removal of corrosive residues in most applications.

REPAIRING SOLDERED JOINTS

Fix the component by first soldering two diagonally-opposite end leads. Use only a low voltage soldering iron (less than 24 V) applied to the flat part of the lead. Contact time must be limited to 10 seconds at up to 300 °C. When using a dedicated tool, all other leads can be soldered in one operation within 2 to 5 seconds between 270 and 320 °C.

I²C-bus controlled economy PAL/NTSC and NTSC TV-processors

TDA837x family

DEFINITIONS

Data sheet status	
Objective specification	This data sheet contains target or goal specifications for product development.
Preliminary specification	This data sheet contains preliminary data; supplementary data may be published later.
Product specification	This data sheet contains final product specifications.
Short-form specification	The data in this specification is extracted from a full data sheet with the same type number and title. For detailed information see the relevant data sheet or data handbook.
Limiting values	
Limiting values given are in accordance with the Absolute Maximum Rating System (IEC 134). Stress above one or more of the limiting values may cause permanent damage to the device. These are stress ratings only and operation of the device at these or at any other conditions above those given in the Characteristics sections of the specification is not implied. Exposure to limiting values for extended periods may affect device reliability.	
Application information	
Where application information is given, it is advisory and does not form part of the specification.	

LIFE SUPPORT APPLICATIONS

These products are not designed for use in life support appliances, devices, or systems where malfunction of these products can reasonably be expected to result in personal injury. Philips customers using or selling these products for use in such applications do so at their own risk and agree to fully indemnify Philips for any damages resulting from such improper use or sale.

PURCHASE OF PHILIPS I²C COMPONENTS



Purchase of Philips I²C components conveys a license under the Philips' I²C patent to use the components in the I²C system provided the system conforms to the I²C specification defined by Philips. This specification can be ordered using the code 9398 393 40011.

I²C-bus controlled economy PAL/NTSC
and NTSC TV-processors

TDA837x family

NOTES

I²C-bus controlled economy PAL/NTSC
and NTSC TV-processors

TDA837x family

NOTES

I²C-bus controlled economy PAL/NTSC
and NTSC TV-processors

TDA837x family

NOTES

Philips Semiconductors – a worldwide company

Argentina: see South America

Australia: 34 Waterloo Road, NORTH RYDE, NSW 2113,
Tel. +61 2 9805 4455, Fax. +61 2 9805 4466

Austria: Computerstr. 6, A-1101 WIEN, P.O. Box 213,
Tel. +43 1 60 101, Fax. +43 1 60 101 1210

Belarus: Hotel Minsk Business Center, Bld. 3, r. 1211, Volodarski Str. 6,
220050 MINSK, Tel. +375 172 200 733, Fax. +375 172 200 773

Belgium: see The Netherlands

Brazil: see South America

Bulgaria: Philips Bulgaria Ltd., Energoproject, 15th floor,
51 James Bourchier Blvd., 1407 SOFIA,
Tel. +359 2 689 211, Fax. +359 2 689 102

Canada: PHILIPS SEMICONDUCTORS/COMPONENTS,
Tel. +1 800 234 7381

China/Hong Kong: 501 Hong Kong Industrial Technology Centre,
72 Tat Chee Avenue, Kowloon Tong, HONG KONG,
Tel. +852 2319 7888, Fax. +852 2319 7700

Colombia: see South America

Czech Republic: see Austria

Denmark: Prags Boulevard 80, PB 1919, DK-2300 COPENHAGEN S,
Tel. +45 32 88 2636, Fax. +45 31 57 0044

Finland: Sinikalliontie 3, FIN-02630 ESPOO,
Tel. +358 9 615800, Fax. +358 9 61580920

France: 4 Rue du Port-aux-Vins, BP317, 92156 SURESNES Cedex,
Tel. +33 1 40 99 6161, Fax. +33 1 40 99 6427

Germany: Hammerbrookstraße 69, D-20097 HAMBURG,
Tel. +49 40 23 53 60, Fax. +49 40 23 536 300

Greece: No. 15, 25th March Street, GR 17778 TAVROS/ATHENS,
Tel. +30 1 4894 339/239, Fax. +30 1 4814 240

Hungary: see Austria

India: Philips INDIA Ltd, Shivsagar Estate, A Block, Dr. Annie Besant Rd.
Worli, MUMBAI 400 018, Tel. +91 22 4938 541, Fax. +91 22 4938 722

Indonesia: see Singapore

Ireland: Newstead, Clonskeagh, DUBLIN 14,
Tel. +353 1 7640 000, Fax. +353 1 7640 200

Israel: RAPAC Electronics, 7 Kehilat Saloniki St, PO Box 18053,
TEL AVIV 61180, Tel. +972 3 645 0444, Fax. +972 3 649 1007

Italy: PHILIPS SEMICONDUCTORS, Piazza IV Novembre 3,
20124 MILANO, Tel. +39 2 6752 2531, Fax. +39 2 6752 2557

Japan: Philips Bldg 13-37, Kohnan 2-chome, Minato-ku, TOKYO 108,
Tel. +81 3 3740 5130, Fax. +81 3 3740 5077

Korea: Philips House, 260-199 Itaewon-dong, Yongsan-ku, SEOUL,
Tel. +82 2 709 1412, Fax. +82 2 709 1415

Malaysia: No. 76 Jalan Universiti, 46200 PETALING JAYA, SELANGOR,
Tel. +60 3 750 5214, Fax. +60 3 757 4880

Mexico: 5900 Gateway East, Suite 200, EL PASO, TEXAS 79905,
Tel. +9-5 800 234 7381

Middle East: see Italy

Netherlands: Postbus 90050, 5600 PB EINDHOVEN, Bldg. VB,
Tel. +31 40 27 82785, Fax. +31 40 27 88399

New Zealand: 2 Wagener Place, C.P.O. Box 1041, AUCKLAND,
Tel. +64 9 849 4160, Fax. +64 9 849 7811

Norway: Box 1, Manglerud 0612, OSLO,
Tel. +47 22 74 8000, Fax. +47 22 74 8341

Philippines: Philips Semiconductors Philippines Inc.,
106 Valero St. Salcedo Village, P.O. Box 2108 MCC, MAKATI,
Metro MANILA, Tel. +63 2 816 6380, Fax. +63 2 817 3474

Poland: Ul. Lukiska 10, PL 04-123 WARSZAWA,
Tel. +48 22 612 2831, Fax. +48 22 612 2327

Portugal: see Spain

Romania: see Italy

Russia: Philips Russia, Ul. Usatcheva 35A, 119048 MOSCOW,
Tel. +7 095 755 6918, Fax. +7 095 755 6919

Singapore: Lorong 1, Toa Payoh, SINGAPORE 1231,
Tel. +65 350 2538, Fax. +65 251 6500

Slovakia: see Austria

Slovenia: see Italy

South Africa: S.A. PHILIPS Pty Ltd., 195-215 Main Road Martindale,
2092 JOHANNESBURG, P.O. Box 7430 Johannesburg 2000,
Tel. +27 11 470 5911, Fax. +27 11 470 5494

South America: Rua do Rocio 220, 5th floor, Suite 51,
04552-903 São Paulo, SÃO PAULO - SP, Brazil,
Tel. +55 11 821 2333, Fax. +55 11 829 1849

Spain: Balmes 22, 08007 BARCELONA,
Tel. +34 3 301 6312, Fax. +34 3 301 4107

Sweden: Kottbygatan 7, Akalla, S-16485 STOCKHOLM,
Tel. +46 8 632 2000, Fax. +46 8 632 2745

Switzerland: Allmendstrasse 140, CH-8027 ZÜRICH,
Tel. +41 1 488 2686, Fax. +41 1 481 7730

Taiwan: Philips Semiconductors, 6F, No. 96, Chien Kuo N. Rd., Sec. 1,
TAIPEI, Taiwan Tel. +886 2 2134 2865, Fax. +886 2 2134 2874

Thailand: PHILIPS ELECTRONICS (THAILAND) Ltd.,
209/2 Sanpavuth-Bangna Road Prakanong, BANGKOK 10260,
Tel. +66 2 745 4090, Fax. +66 2 398 0793

Turkey: Talatpasa Cad. No. 5, 80640 GÜLTEPE/ISTANBUL,
Tel. +90 212 279 2770, Fax. +90 212 282 6707

Ukraine: PHILIPS UKRAINE, 4 Patrice Lumumba str., Building B, Floor 7,
252042 KIEV, Tel. +380 44 264 2776, Fax. +380 44 268 0461

United Kingdom: Philips Semiconductors Ltd., 276 Bath Road, Hayes,
MIDDLESEX UB3 5BX, Tel. +44 181 730 5000, Fax. +44 181 754 8421

United States: 811 East Arques Avenue, SUNNYVALE, CA 94088-3409,
Tel. +1 800 234 7381

Uruguay: see South America

Vietnam: see Singapore

Yugoslavia: PHILIPS, Trg N. Pasica 5/v, 11000 BEOGRAD,
Tel. +381 11 625 344, Fax. +381 11 635 777

For all other countries apply to: Philips Semiconductors, Marketing & Sales Communications,
Building BE-p, P.O. Box 218, 5600 MD EINDHOVEN, The Netherlands, Fax. +31 40 27 24825

Internet: <http://www.semiconductors.philips.com>

© Philips Electronics N.V. 1997

SCA54

All rights are reserved. Reproduction in whole or in part is prohibited without the prior written consent of the copyright owner.

The information presented in this document does not form part of any quotation or contract, is believed to be accurate and reliable and may be changed without notice. No liability will be accepted by the publisher for any consequence of its use. Publication thereof does not convey nor imply any license under patent- or other industrial or intellectual property rights.

Printed in The Netherlands

547047/1200/01/pp72

Date of release: 1997 Jul 01

Document order number: 9397 750 01808

Let's make things better.

Philips
Semiconductors



PHILIPS