

DATA SHEET

TDA1517; TDA1517P **2 × 6 W stereo power amplifier**

Product specification
Supersedes data of 1998 Apr 28
File under Integrated Circuits, IC01

2002 Jan 17

2 × 6 W stereo power amplifier**TDA1517; TDA1517P****FEATURES**

- Requires very few external components
- High output power
- Fixed gain
- Good ripple rejection
- Mute/standby switch
- AC and DC short-circuit safe to ground and V_P
- Thermally protected
- Reverse polarity safe
- Capability to handle high energy on outputs ($V_P = 0$ V)
- No switch-on/switch-off plop
- Electrostatic discharge protection.

GENERAL DESCRIPTION

The TDA1517 is an integrated class-B dual output amplifier in a plastic single in-line medium power package with fin (SIL9MPF) and a plastic heat-dissipating dual in-line package (HDIP18). The device is primarily developed for multi-media applications.

QUICK REFERENCE DATA

SYMBOL	PARAMETER	CONDITIONS	MIN.	TYP.	MAX.	UNIT
V_P	supply voltage		6.0	14.4	18.0	V
I_{ORM}	repetitive peak output current		–	–	2.5	A
$I_{q(tot)}$	total quiescent current		–	40	80	mA
I_{sb}	standby current		–	0.1	100	μ A
I_{sw}	switch-on current		–	–	40	μ A
$ Z_i $	input impedance		50	–	–	k Ω
P_o	output power	$R_L = 4 \Omega$; THD = 0.5%	–	5	–	W
		$R_L = 4 \Omega$; THD = 10%	–	6	–	W
SVRR	supply voltage ripple rejection	$f_i = 100$ Hz to 10 kHz	48	–	–	dB
α_{cs}	channel separation		40	–	–	dB
G_v	closed loop voltage gain		19	20	21	dB
$V_{no(rms)}$	noise output voltage (RMS value)		–	50	–	μ V
T_c	crystal temperature		–	–	150	$^{\circ}$ C

ORDERING INFORMATION

TYPE NUMBER	PACKAGE		
	NAME	DESCRIPTION	VERSION
TDA1517	SIL9MPF	plastic single in-line medium power package with fin; 9 leads	SOT110-1
TDA1517P	HDIP18	plastic heat-dissipating dual in-line package; 18 leads	SOT398-1

2 × 6 W stereo power amplifier

TDA1517; TDA1517P

BLOCK DIAGRAM

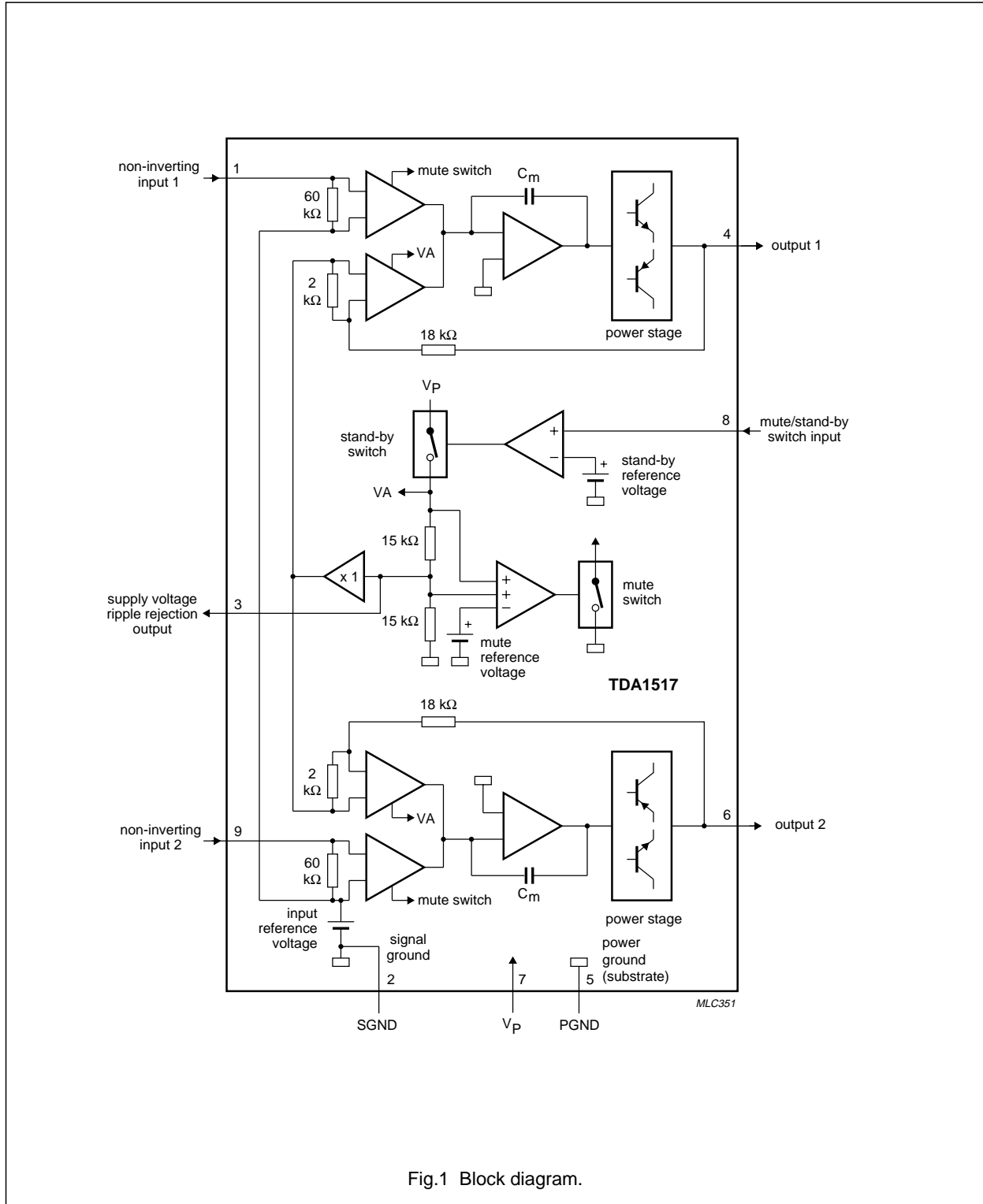

Fig.1 Block diagram.

2 × 6 W stereo power amplifier

TDA1517; TDA1517P

PINNING

SYMBOL	PIN	DESCRIPTION
-INV1	1	non-inverting input 1
SGND	2	signal ground
SVRR	3	supply voltage ripple rejection output
OUT1	4	output 1
PGND	5	power ground
OUT2	6	output 2
V _P	7	supply voltage
M/SS	8	mute/standby switch input
-INV2	9	non-inverting input 2

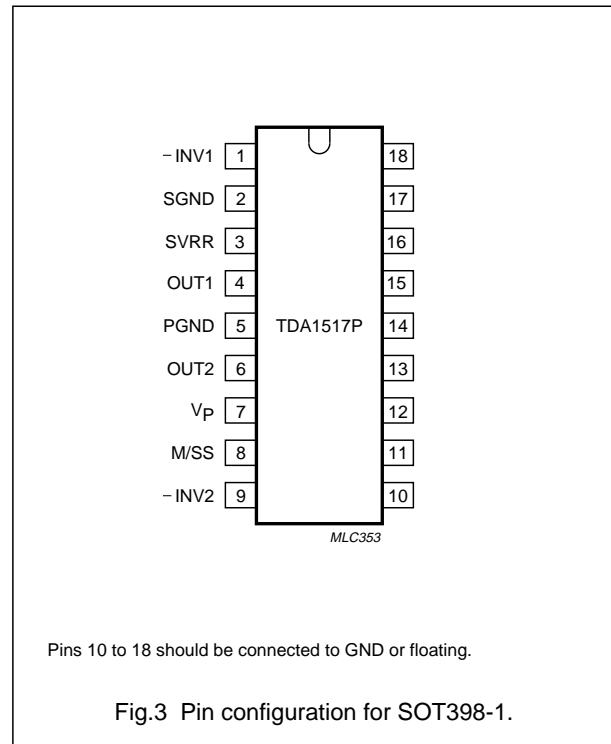
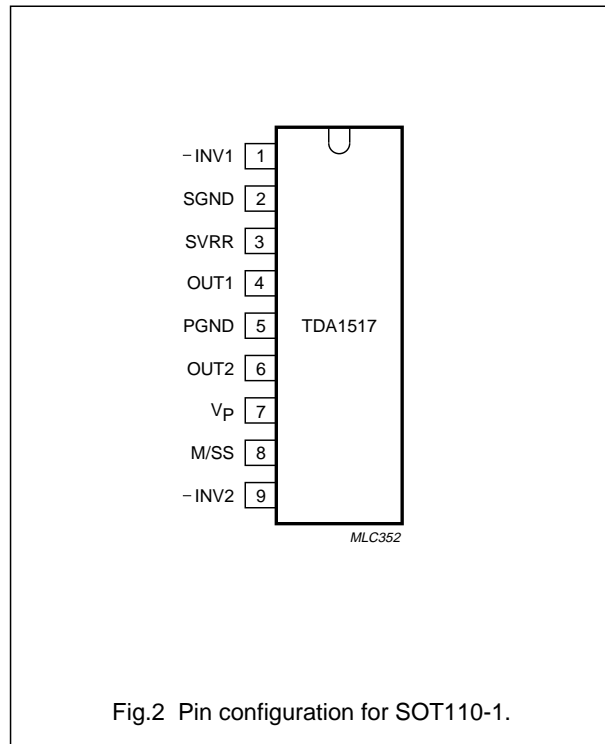

FUNCTIONAL DESCRIPTION

The TDA1517 contains two identical amplifiers with differential input stages. The gain of each amplifier is fixed at 20 dB. A special feature of the device is the mute/standby switch which has the following features:

- Low standby current (<100 μA)
- Low mute/standby switching current (low cost supply switch)
- Mute condition.

2 × 6 W stereo power amplifier

TDA1517; TDA1517P

LIMITING VALUES

In accordance with the Absolute Maximum Rating System (IEC 60134).

SYMBOL	PARAMETER	CONDITIONS	MIN.	MAX.	UNIT
V _P	supply voltage	operating	–	18	V
		no signal	–	20	V
V _{P(sc)}	AC and DC short-circuit safe voltage		–	18	V
V _{P(r)}	reverse polarity		–	6	V
ERG _O	energy handling capability at outputs	V _P = 0 V	–	200	mJ
I _{OSM}	non-repetitive peak output current		–	4	A
I _{ORM}	repetitive peak output current		–	2.5	A
P _{tot}	total power dissipation	see Fig.4	–	15	W
T _{stg}	storage temperature		–55	+150	°C
T _{amb}	operating ambient temperature		–40	+85	°C
T _c	crystal temperature		–	150	°C

THERMAL RESISTANCE

SYMBOL	TYPE NUMBER	PARAMETER	VALUE	UNIT
R _{th j-c}	TDA1517	thermal resistance from junction to case	8	K/W
R _{th j-p}	TDA1517P	thermal resistance from junction to pins	15	K/W
R _{th j-a}	TDA1517; TDA1517P	thermal resistance from junction to ambient	50	K/W

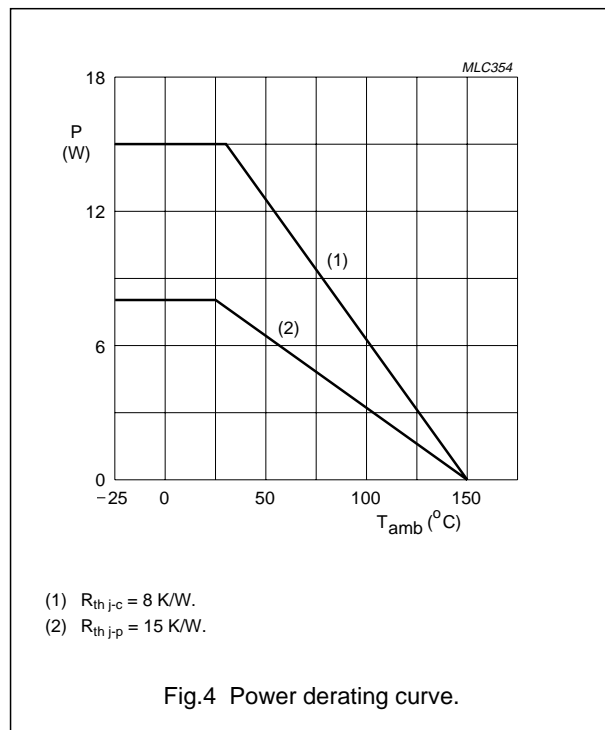

2 × 6 W stereo power amplifier**TDA1517; TDA1517P****DC CHARACTERISTICS**

$V_P = 14.4 \text{ V}$; $T_{\text{amb}} = 25 \text{ °C}$; measured in Fig.6; unless otherwise specified.

SYMBOL	PARAMETER	CONDITIONS	MIN.	TYP.	MAX.	UNIT
Supply						
V_P	supply voltage	note 1	6.0	14.4	18.0	V
$I_{q(\text{tot})}$	total quiescent current		–	40	80	mA
V_O	DC output voltage		–	6.95	–	V
Mute/standby switch						
V_8	switch-on voltage level	see Fig.5	8.5	–	–	V
Mute condition						
V_O	output signal in mute position	$V_{l(\text{max})} = 1 \text{ V}$; $f_i = 20 \text{ Hz to } 15 \text{ kHz}$	–	–	2	mV
Standby condition						
I_{sb}	DC current in standby condition		–	–	100	μA
V_{sw}	switch-on current		–	12	40	μA

Note

1. The circuit is DC adjusted at $V_P = 6 \text{ to } 18 \text{ V}$ and AC operating at $V_P = 8.5 \text{ to } 18 \text{ V}$.

2 × 6 W stereo power amplifier**TDA1517; TDA1517P****AC CHARACTERISTICS**

$V_P = 14.4\text{ V}$; $R_L = 4\ \Omega$; $f = 1\text{ kHz}$; $T_{\text{amb}} = 25\text{ °C}$; measured in Fig.6; unless otherwise specified.

SYMBOL	PARAMETER	CONDITIONS	MIN.	TYP.	MAX.	UNIT
P_o	output power	THD = 0.5%; note 1	4	5	–	W
		THD = 10%; note 1	5.5	6.0	–	W
THD	total harmonic distortion	$P_o = 1\text{ W}$	–	0.1	–	%
f_{lr}	low frequency roll-off	at –3 dB; note 2	–	45	–	Hz
f_{hr}	high frequency roll-off	at –1 dB	20	–	–	kHz
G_v	closed loop voltage gain		19	20	21	dB
SVRR	supply voltage ripple rejection	note 3				
	on		48	–	–	dB
	mute		48	–	–	dB
	standby		80	–	–	dB
$ Z_i $	input impedance		50	60	75	k Ω
V_{no}	noise output voltage					
	on	$R_s = 0\ \Omega$; note 4	–	50	–	μV
	on	$R_s = 10\ \Omega$; note 4	–	70	100	μV
	mute	note 5	–	50	–	μV
α_{cs}	channel separation	$R_s = 10\ \Omega$	40	–	–	dB
$ \Delta G_v $	channel unbalance		–	0.1	1	dB

Notes

- Output power is measured directly at the output pins of the IC.
- Frequency response externally fixed.
- Ripple rejection measured at the output with a source impedance of 0 Ω , maximum ripple amplitude of 2 V (p-p) and a frequency between 100 Hz and 10 kHz.
- Noise voltage measured in a bandwidth of 20 Hz to 20 kHz.
- Noise output voltage independent of R_s ($V_i = 0\text{ V}$).

2 × 6 W stereo power amplifier

TDA1517; TDA1517P

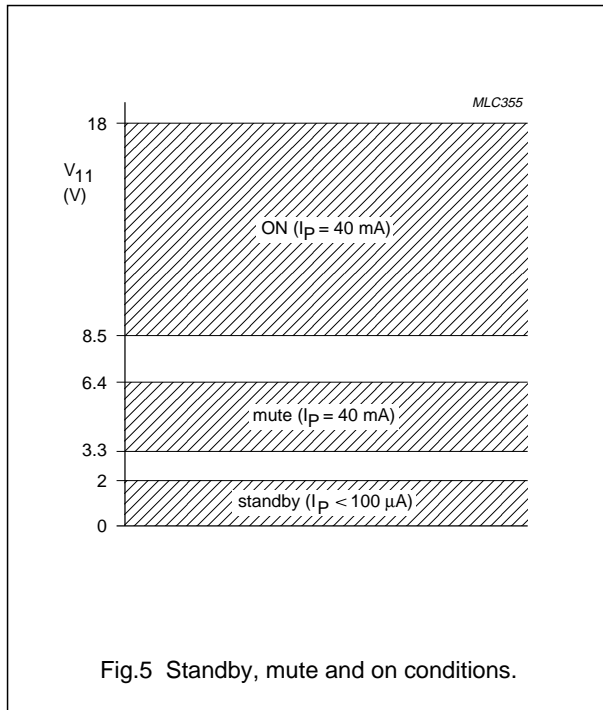

APPLICATION INFORMATION

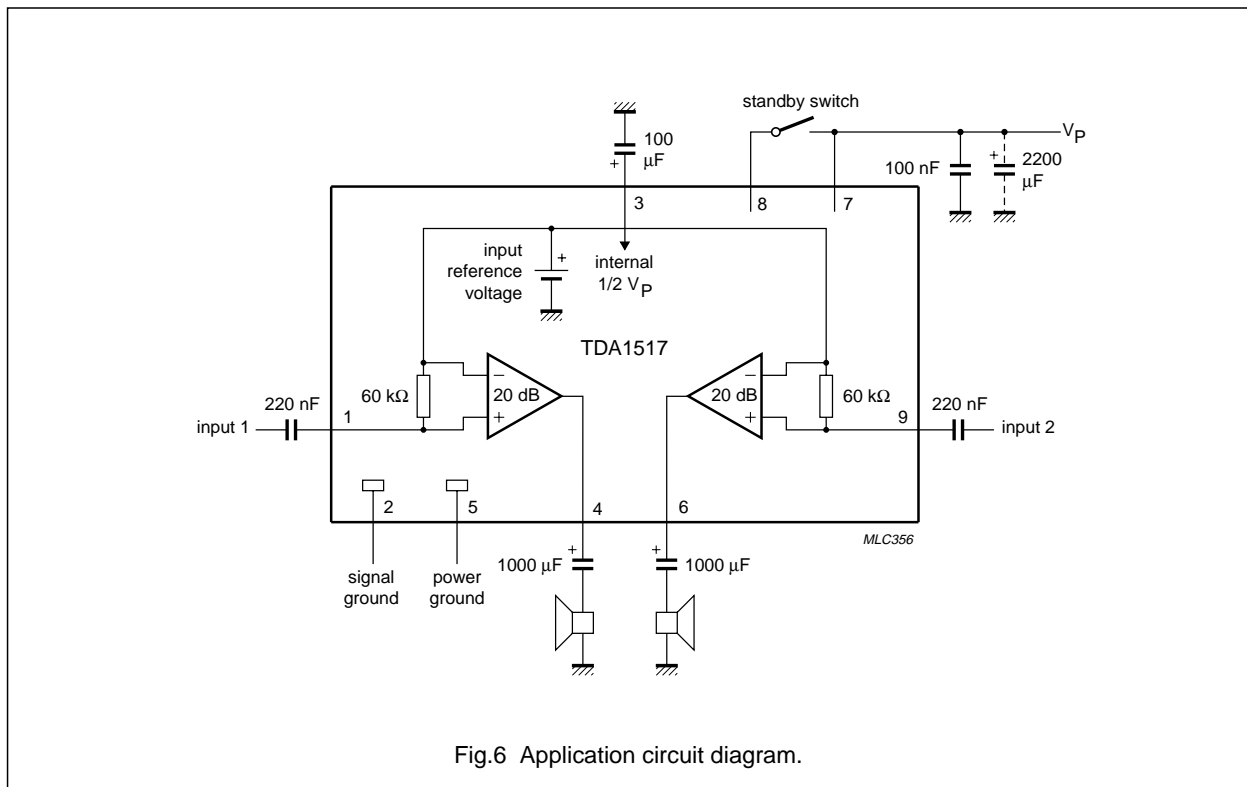

2 × 6 W stereo power amplifier

TDA1517; TDA1517P

PACKAGE OUTLINES

SIL9MPF: plastic single in-line medium power package with fin; 9 leads

SOT110-1

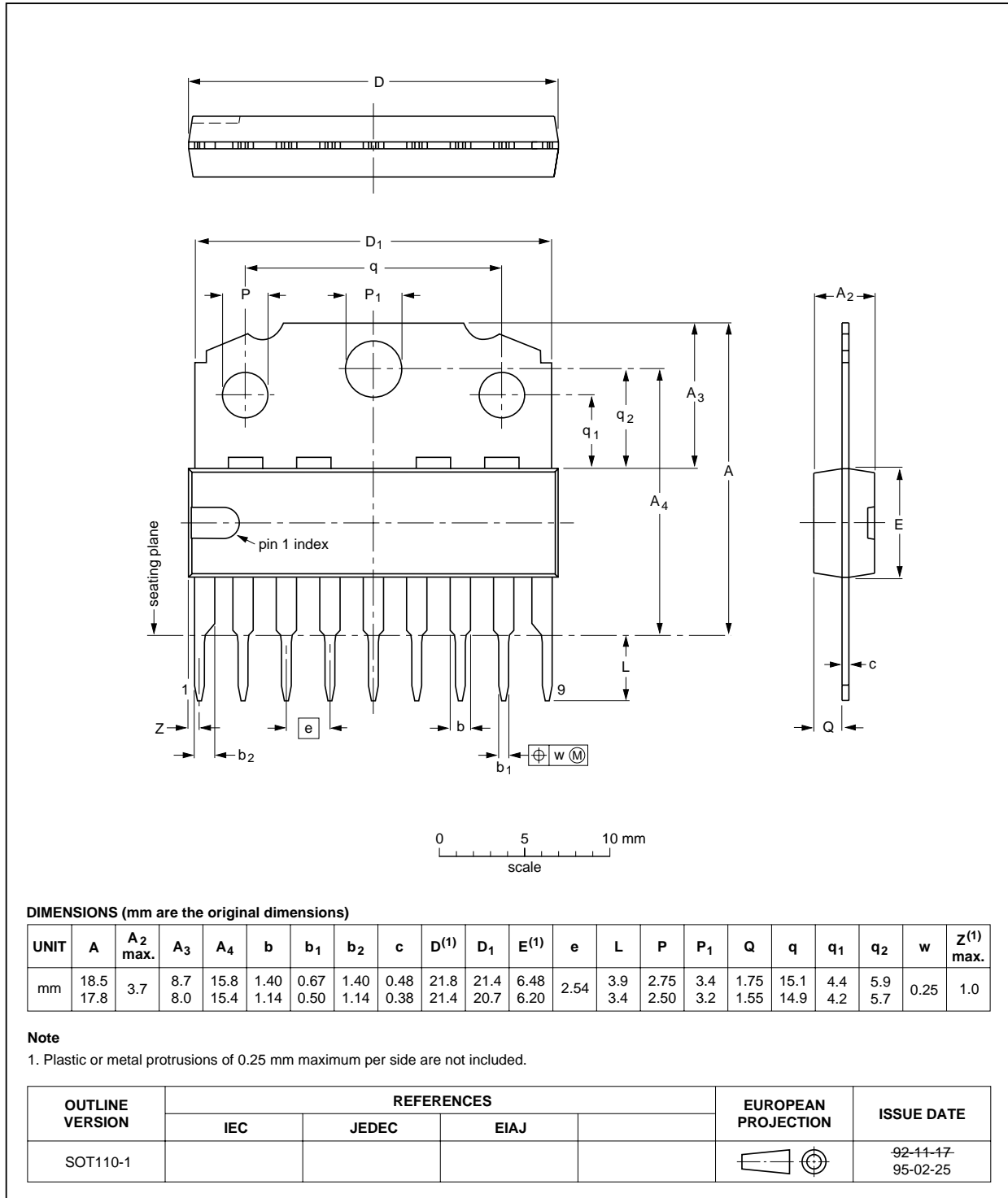

2 × 6 W stereo power amplifier

TDA1517; TDA1517P

HDIP18: plastic heat-dissipating dual in-line package; 18 leads

SOT398-1

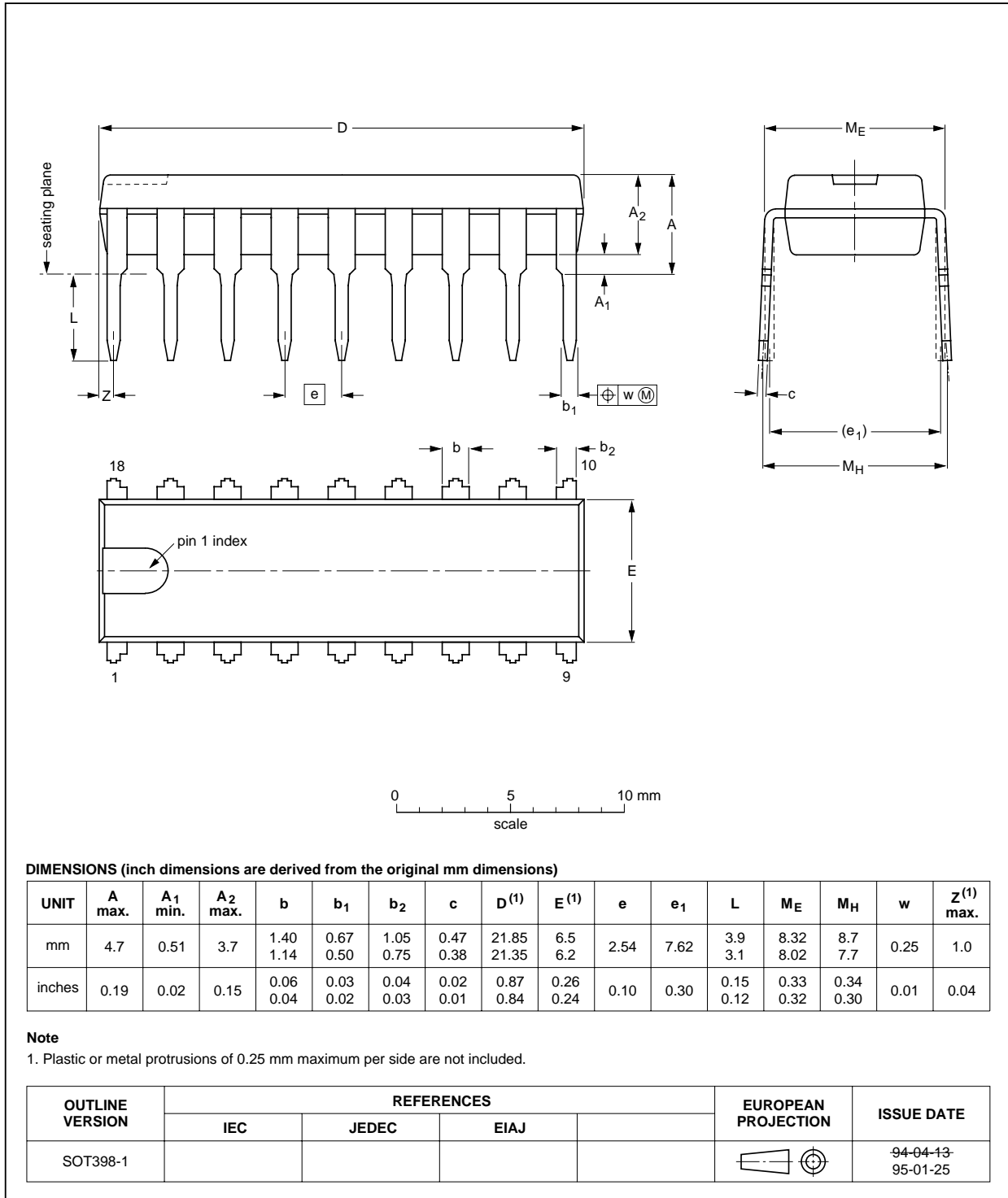

2 × 6 W stereo power amplifier**TDA1517; TDA1517P****SOLDERING****Introduction to soldering through-hole mount packages**

This text gives a brief insight to wave, dip and manual soldering. A more in-depth account of soldering ICs can be found in our "Data Handbook IC26; Integrated Circuit Packages" (document order number 9398 652 90011).

Wave soldering is the preferred method for mounting of through-hole mount IC packages on a printed-circuit board.

Soldering by dipping or by solder wave

The maximum permissible temperature of the solder is 260 °C; solder at this temperature must not be in contact with the joints for more than 5 seconds.

The total contact time of successive solder waves must not exceed 5 seconds.

The device may be mounted up to the seating plane, but the temperature of the plastic body must not exceed the specified maximum storage temperature ($T_{stg(max)}$). If the printed-circuit board has been pre-heated, forced cooling may be necessary immediately after soldering to keep the temperature within the permissible limit.

Manual soldering

Apply the soldering iron (24 V or less) to the lead(s) of the package, either below the seating plane or not more than 2 mm above it. If the temperature of the soldering iron bit is less than 300 °C it may remain in contact for up to 10 seconds. If the bit temperature is between 300 and 400 °C, contact may be up to 5 seconds.

Suitability of through-hole mount IC packages for dipping and wave soldering methods

PACKAGE	SOLDERING METHOD	
	DIPPING	WAVE
DBS, DIP, HDIP, SDIP, SIL	suitable	suitable ⁽¹⁾

Note

- For SDIP packages, the longitudinal axis must be parallel to the transport direction of the printed-circuit board.

2 × 6 W stereo power amplifier**TDA1517; TDA1517P****DATA SHEET STATUS**

DATA SHEET STATUS⁽¹⁾	PRODUCT STATUS⁽²⁾	DEFINITIONS
Objective data	Development	This data sheet contains data from the objective specification for product development. Philips Semiconductors reserves the right to change the specification in any manner without notice.
Preliminary data	Qualification	This data sheet contains data from the preliminary specification. Supplementary data will be published at a later date. Philips Semiconductors reserves the right to change the specification without notice, in order to improve the design and supply the best possible product.
Product data	Production	This data sheet contains data from the product specification. Philips Semiconductors reserves the right to make changes at any time in order to improve the design, manufacturing and supply. Changes will be communicated according to the Customer Product/Process Change Notification (CPCN) procedure SNW-SQ-650A.

Notes

1. Please consult the most recently issued data sheet before initiating or completing a design.
2. The product status of the device(s) described in this data sheet may have changed since this data sheet was published. The latest information is available on the Internet at URL <http://www.semiconductors.philips.com>.

DEFINITIONS

Short-form specification — The data in a short-form specification is extracted from a full data sheet with the same type number and title. For detailed information see the relevant data sheet or data handbook.

Limiting values definition — Limiting values given are in accordance with the Absolute Maximum Rating System (IEC 60134). Stress above one or more of the limiting values may cause permanent damage to the device.

These are stress ratings only and operation of the device at these or at any other conditions above those given in the Characteristics sections of the specification is not implied. Exposure to limiting values for extended periods may affect device reliability.

Application information — Applications that are described herein for any of these products are for illustrative purposes only. Philips Semiconductors make no representation or warranty that such applications will be suitable for the specified use without further testing or modification.

DISCLAIMERS

Life support applications — These products are not designed for use in life support appliances, devices, or systems where malfunction of these products can reasonably be expected to result in personal injury. Philips Semiconductors customers using or selling these products for use in such applications do so at their own risk and agree to fully indemnify Philips Semiconductors for any damages resulting from such application.

Right to make changes — Philips Semiconductors reserves the right to make changes, without notice, in the products, including circuits, standard cells, and/or software, described or contained herein in order to improve design and/or performance. Philips Semiconductors assumes no responsibility or liability for the use of any of these products, conveys no licence or title under any patent, copyright, or mask work right to these products, and makes no representations or warranties that these products are free from patent, copyright, or mask work right infringement, unless otherwise specified.

2 × 6 W stereo power amplifier

TDA1517; TDA1517P

NOTES

2 × 6 W stereo power amplifier

TDA1517; TDA1517P

NOTES

2 × 6 W stereo power amplifier

TDA1517; TDA1517P

NOTES

Philips Semiconductors – a worldwide company

Contact information

For additional information please visit <http://www.semiconductors.philips.com>. Fax: **+31 40 27 24825**

For sales offices addresses send e-mail to: sales.addresses@www.semiconductors.philips.com.

© Koninklijke Philips Electronics N.V. 2002

SCA74

All rights are reserved. Reproduction in whole or in part is prohibited without the prior written consent of the copyright owner.

The information presented in this document does not form part of any quotation or contract, is believed to be accurate and reliable and may be changed without notice. No liability will be accepted by the publisher for any consequence of its use. Publication thereof does not convey nor imply any license under patent- or other industrial or intellectual property rights.

Printed in The Netherlands

753503/04/pp16

Date of release: 2002 Jan 17

Document order number: 9397 750 08925

Let's make things better.

**Philips
Semiconductors**



PHILIPS