

74HC4040; 74HCT4040

12-stage binary ripple counter

Rev. 03 — 14 September 2005

Product data sheet

1. General description

The 74HC4040; 74HCT4040 are high-speed Si-gate CMOS devices and are pin compatible with the HEF4040B series. They are specified in compliance with JEDEC standard no. 7A.

The 74HC4040; 74HCT4040 are 12-stage binary ripple counters with a clock input (\overline{CP}), an overriding asynchronous master reset input (MR) and twelve parallel outputs (Q0 to Q11). The counter advances on the HIGH-to-LOW transition of \overline{CP} .

A HIGH on MR clears all counter stages and forces all outputs LOW, independent of the state of \overline{CP} .

Each counter stage is a static toggle flip-flop.

2. Features

- Multiple package options
- Complies with JEDEC standard no. 7A
- ESD protection:
 - ◆ HBM JESD22-A114-C exceeds 2000 V
 - ◆ MM JESD22-A115-A exceeds 200 V
- Specified from $-40\text{ }^{\circ}\text{C}$ to $+85\text{ }^{\circ}\text{C}$ and from $-40\text{ }^{\circ}\text{C}$ to $+125\text{ }^{\circ}\text{C}$

3. Applications

- Frequency dividing circuits
- Time delay circuits
- Control counters

4. Quick reference data

Table 1: Quick reference data

$GND = 0\text{ V}$; $T_{amb} = 25\text{ }^{\circ}\text{C}$; $t_r = t_f = 6\text{ ns}$.

Symbol	Parameter	Conditions	Min	Typ	Max	Unit
Type 74HC4040						
t_{PHL} , t_{PLH}	propagation delay					
	\overline{CP} to Q0	$C_L = 15\text{ pF}$; $V_{CC} = 5\text{ V}$	-	14	-	ns
	Qn to Qn+1	$C_L = 15\text{ pF}$; $V_{CC} = 5\text{ V}$	-	8	-	ns

PHILIPS

Table 1: Quick reference data ...continuedGND = 0 V; $T_{amb} = 25\text{ }^{\circ}\text{C}$; $t_r = t_f = 6\text{ ns}$.

Symbol	Parameter	Conditions	Min	Typ	Max	Unit
f_{max}	maximum operating frequency	$C_L = 15\text{ pF}$; $V_{CC} = 5\text{ V}$	-	90	-	MHz
C_i	input capacitance		-	3.5	-	pF
C_{PD}	power dissipation capacitance	$V_I = \text{GND to } V_{CC}$	-	20	-	pF
Type 74HCT4040						
t_{PHL}, t_{PLH}	propagation delay					
	\overline{CP} to Q0	$C_L = 15\text{ pF}$; $V_{CC} = 5\text{ V}$	-	16	-	ns
	Qn to Qn+1	$C_L = 15\text{ pF}$; $V_{CC} = 5\text{ V}$	-	8	-	ns
f_{max}	maximum operating frequency	$C_L = 15\text{ pF}$; $V_{CC} = 5\text{ V}$	-	79	-	MHz
C_i	input capacitance		-	3.5	-	pF
C_{PD}	power dissipation capacitance	$V_I = \text{GND to } V_{CC} - 1.5\text{ V}$	-	20	-	pF

[1] C_{PD} is used to determine the dynamic power dissipation (P_D in μW):

$$P_D = C_{PD} \times V_{CC}^2 \times f_i + \sum(C_L \times V_{CC}^2 \times f_o) \text{ where:}$$

 f_i = input frequency in MHz; f_o = output frequency in MHz; $\sum(C_L \times V_{CC}^2 \times f_o)$ = sum of outputs; C_L = output load capacitance in pF; V_{CC} = supply voltage in V.

5. Ordering information

Table 2: Ordering information

Type number	Package			
	Temperature range	Name	Description	Version
74HC4040N	-40 °C to +125 °C	DIP16	plastic dual in-line package; 16 leads (300 mil); long body	SOT38-1
74HC4040D	-40 °C to +125 °C	SO16	plastic small outline package; 16 leads; body width 3.9 mm	SOT109-1
74HC4040DB	-40 °C to +125 °C	SSOP16	plastic shrink small outline package; 16 leads; body width 5.3 mm	SOT338-1
74HC4040PW	-40 °C to +125 °C	TSSOP16	plastic thin shrink small outline package; 16 leads; body width 4.4 mm	SOT403-1
74HC4040BQ	-40 °C to +125 °C	DHVQFN16	plastic dual in-line compatible thermal enhanced very thin quad flat package; no leads; 16 terminals; body 2.5 × 3.5 × 0.85 mm	SOT763-1
74HCT4040N	-40 °C to +125 °C	DIP16	plastic dual in-line package; 16 leads (300 mil); long body	SOT38-1
74HCT4040D	-40 °C to +125 °C	SO16	plastic small outline package; 16 leads; body width 3.9 mm	SOT109-1

Table 2: Ordering information ...continued

Type number	Package			Version
	Temperature range	Name	Description	
74HCT4040DB	-40 °C to +125 °C	SSOP16	plastic shrink small outline package; 16 leads; body width 5.3 mm	SOT338-1
74HCT4040PW	-40 °C to +125 °C	TSSOP16	plastic thin shrink small outline package; 16 leads; body width 4.4 mm	SOT403-1
74HCT4040BQ	-40 °C to +125 °C	DHVQFN16	plastic dual in-line compatible thermal enhanced very thin quad flat package; no leads; 16 terminals; body 2.5 × 3.5 × 0.85 mm	SOT763-1

6. Functional diagram

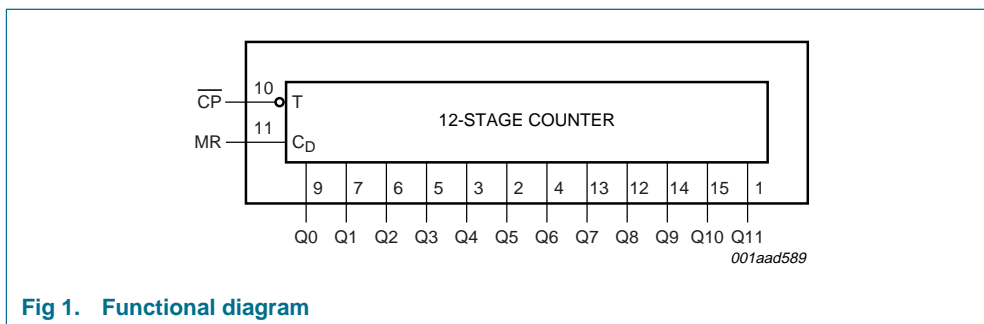

Fig 1. Functional diagram

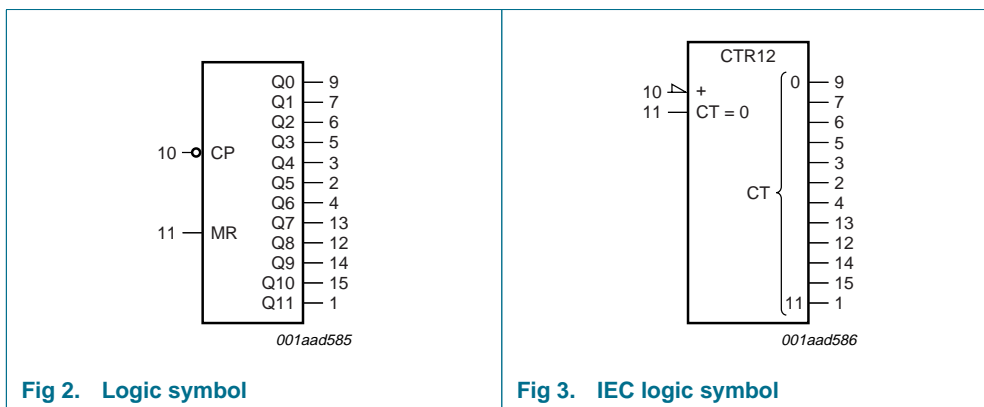
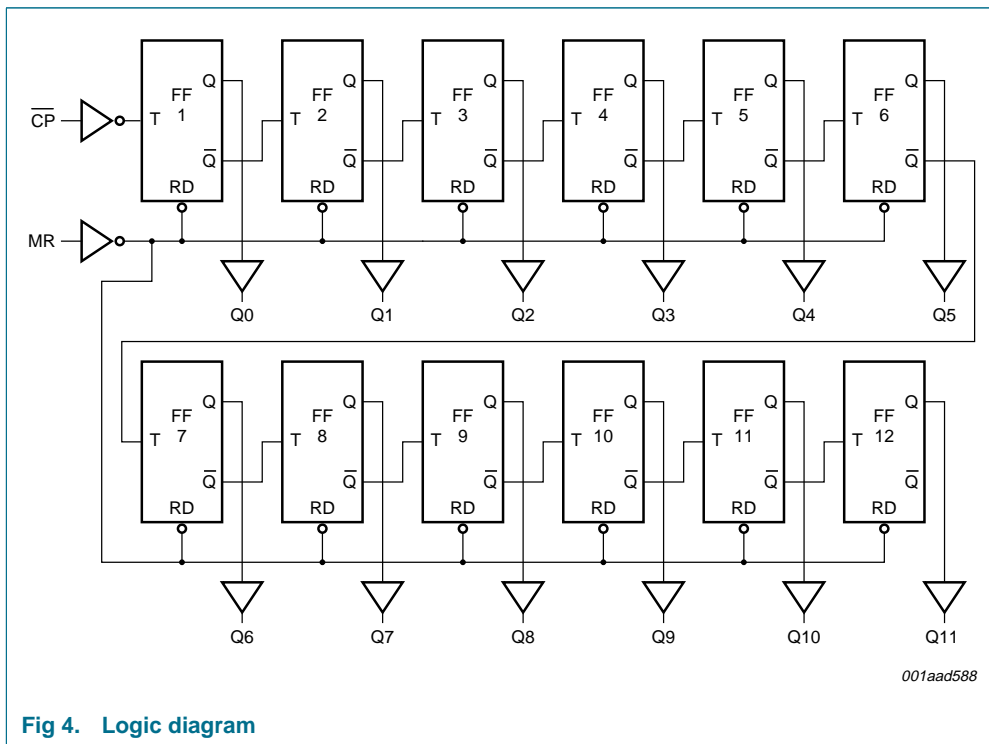

Fig 2. Logic symbol

Fig 3. IEC logic symbol



7. Pinning information

7.1 Pinning

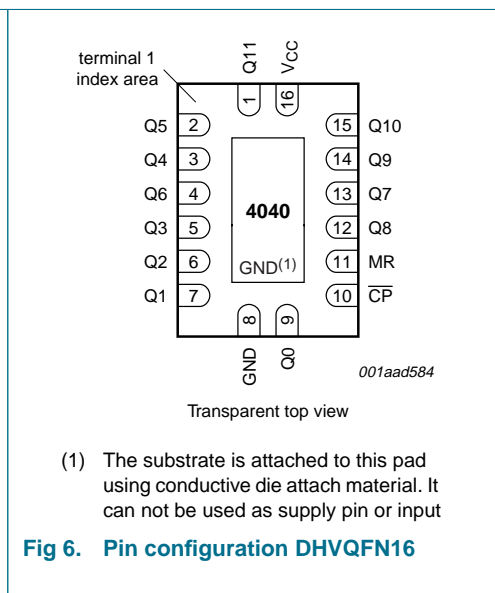
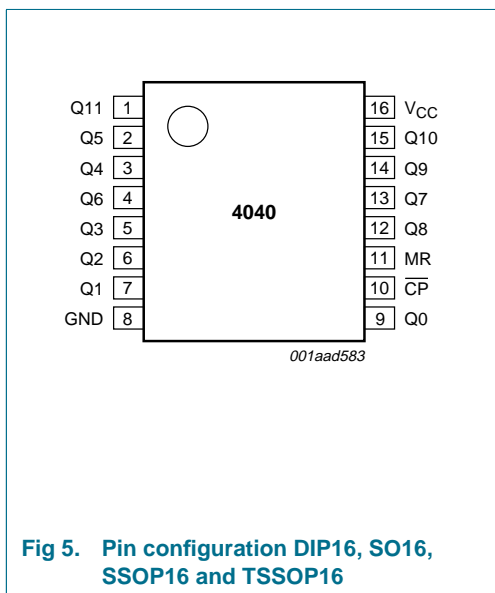

7.2 Pin description

Table 3: Pin description

Symbol	Pin	Description
Q11	1	output 11
Q5	2	output 5
Q4	3	output 4
Q6	4	output 6
Q3	5	output 3
Q2	6	output 2
Q1	7	output 1
GND	8	ground (0 V)
Q0	9	output 0
$\overline{\text{CP}}$	10	clock input (HIGH-to-LOW, edge-triggered)
MR	11	master reset input (active HIGH)
Q8	12	output 8
Q7	13	output 7
Q9	14	output 9
Q10	15	output 10
V _{CC}	16	positive supply voltage

8. Functional description

8.1 Function table

Table 4: Function table

Input		Output
$\overline{\text{CP}}$	MR	Q0 to Q11
↑	L	no change
↓	L	count
X	H	L

- [1] H = HIGH voltage level;
 L = LOW voltage level;
 X = don't care;
 ↑ = LOW-to-HIGH clock transition;
 ↓ = HIGH-to-LOW clock transition.

8.2 Timing diagram

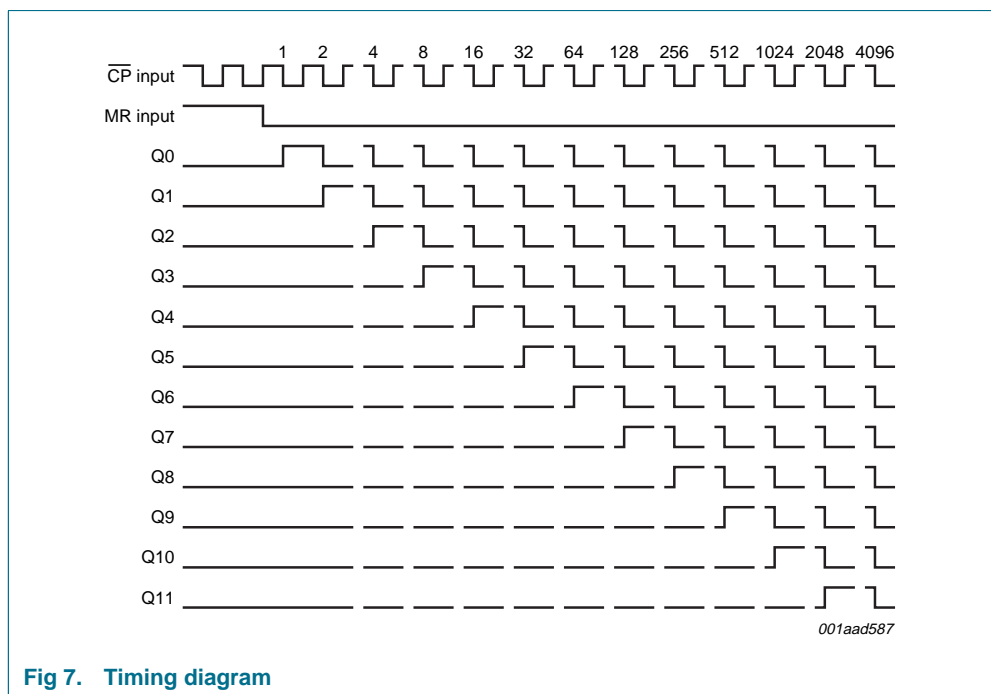

Fig 7. Timing diagram

9. Limiting values

Table 5: Limiting values

In accordance with the Absolute Maximum Rating System (IEC 60134). Voltages are referenced to GND (ground = 0 V).

Symbol	Parameter	Conditions	Min	Max	Unit
V_{CC}	supply voltage		-0.5	+7	V
I_{IK}	input diode current	$V_I < -0.5 \text{ V}$ or $V_I > V_{CC} + 0.5 \text{ V}$	-	± 20	mA
I_{OK}	output diode current	$V_I < -0.5 \text{ V}$ or $V_I > V_{CC} + 0.5 \text{ V}$	-	± 20	mA
I_O	output source or sink current	$-0.5 \text{ V} < V_O < V_{CC} + 0.5 \text{ V}$	-	± 25	mA
I_{CC}	quiescent supply current		-	± 50	mA
I_{GND}	ground current		-	± 50	mA
T_{stg}	storage temperature		-65	+150	°C
P_{tot}	power dissipation	$T_{amb} = -40 \text{ °C to } +125 \text{ °C}$	[1]		
	DIP16 package		-	750	mW
	SO16, SSOP16, TSSOP16 and DHVQFN16 packages		-	500	mW

[1] For DIP16 packages: above 70 °C, P_{tot} derates linearly with 12 mW/K.

For SO16, SSOP16, TSSOP16 and DHVQFN16 packages, above 70 °C, P_{tot} derates linearly with 8 mW/K.

10. Recommended operating conditions

Table 6: Recommended operating conditions

Symbol	Parameter	Conditions	Min	Typ	Max	Unit
type 74HC4040						
V_{CC}	supply voltage		2.0	5.0	6.0	V
V_I	input voltage		0	-	V_{CC}	V
V_O	output voltage		0	-	V_{CC}	V
T_{amb}	ambient temperature	see Section 11 and 12 per device	-40	-	+125	°C
t_r, t_f	input rise and fall times	except for Schmitt-trigger inputs				
		$V_{CC} = 2.0\text{ V}$	-	-	1000	ns
		$V_{CC} = 4.5\text{ V}$	-	6.0	500	ns
		$V_{CC} = 6.0\text{ V}$	-	-	400	ns
type 74HCT4040						
V_{CC}	supply voltage		4.5	5.0	5.5	V
V_I	input voltage		0	-	V_{CC}	V
V_O	output voltage		0	-	V_{CC}	V
T_{amb}	ambient temperature	see Section 11 and 12 per device	-40	-	+125	°C
t_r, t_f	input rise and fall times	except for Schmitt-trigger inputs				
		$V_{CC} = 2.0\text{ V}$	-	-	-	ns
		$V_{CC} = 4.5\text{ V}$	-	6.0	500	ns
		$V_{CC} = 6.0\text{ V}$	-	-	-	ns

11. Static characteristics

Table 7: Static characteristics for 74HC4040

Voltages are referenced to GND (ground = 0 V).

Symbol	Parameter	Conditions	Min	Typ	Max	Unit
$T_{amb} = 25\text{ °C}$						
V_{IH}	HIGH-level input voltage	$V_{CC} = 2.0\text{ V}$	1.5	1.2	-	V
		$V_{CC} = 4.5\text{ V}$	3.15	2.4	-	V
		$V_{CC} = 6.0\text{ V}$	4.2	3.2	-	V
V_{IL}	LOW-level input voltage	$V_{CC} = 2.0\text{ V}$	-	0.8	0.5	V
		$V_{CC} = 4.5\text{ V}$	-	2.1	1.35	V
		$V_{CC} = 6.0\text{ V}$	-	2.8	1.8	V
V_{OH}	HIGH-level output voltage	$V_I = V_{IH}$ or V_{IL}				
		$I_O = -20\text{ }\mu\text{A}; V_{CC} = 2.0\text{ V}$	1.9	2.0	-	V
		$I_O = -20\text{ }\mu\text{A}; V_{CC} = 4.5\text{ V}$	4.4	4.5	-	V
		$I_O = -20\text{ }\mu\text{A}; V_{CC} = 6.0\text{ V}$	5.9	6.0	-	V
		$I_O = -4.0\text{ mA}; V_{CC} = 4.5\text{ V}$	3.98	4.32	-	V
	$I_O = -5.2\text{ mA}; V_{CC} = 6.0\text{ V}$	5.48	5.81	-	V	

Table 7: Static characteristics for 74HC4040 ...continued

Voltages are referenced to GND (ground = 0 V).

Symbol	Parameter	Conditions	Min	Typ	Max	Unit
V _{OL}	LOW-level output voltage	V _I = V _{IH} or V _{IL}				
		I _O = 20 μA; V _{CC} = 2.0 V	-	0	0.1	V
		I _O = 20 μA; V _{CC} = 4.5 V	-	0	0.1	V
		I _O = 20 μA; V _{CC} = 6.0 V	-	0	0.1	V
		I _O = 4.0 mA; V _{CC} = 4.5 V	-	0.15	0.26	V
		I _O = 5.2 mA; V _{CC} = 6.0 V	-	0.16	0.26	V
I _{LI}	input leakage current	V _I = V _{CC} or GND; V _{CC} = 6.0 V	-	-	0.1	μA
I _{CC}	quiescent supply current	V _I = V _{CC} or GND; I _O = 0 A; V _{CC} = 6.0 V	-	-	8.0	μA
C _I	input capacitance		-	3.5	-	pF
T_{amb} = -40 °C to +85 °C						
V _{IH}	HIGH-level input voltage	V _{CC} = 2.0 V	1.5	-	-	V
		V _{CC} = 4.5 V	3.15	-	-	V
		V _{CC} = 6.0 V	4.2	-	-	V
V _{IL}	LOW-level input voltage	V _{CC} = 2.0 V	-	-	0.5	V
		V _{CC} = 4.5 V	-	-	1.35	V
		V _{CC} = 6.0 V	-	-	1.8	V
V _{OH}	HIGH-level output voltage	V _I = V _{IH} or V _{IL}				
		I _O = -20 μA; V _{CC} = 2.0 V	1.9	-	-	V
		I _O = -20 μA; V _{CC} = 4.5 V	4.4	-	-	V
		I _O = -20 μA; V _{CC} = 6.0 V	5.9	-	-	V
		I _O = -4.0 mA; V _{CC} = 4.5 V	3.84	-	-	V
		I _O = -5.2 mA; V _{CC} = 6.0 V;	5.34	-	-	V
V _{OL}	LOW-level output voltage	V _I = V _{IH} or V _{IL}				
		I _O = 20 μA; V _{CC} = 2.0 V	-	-	0.1	V
		I _O = 20 μA; V _{CC} = 4.5 V	-	-	0.1	V
		I _O = 20 μA; V _{CC} = 6.0 V	-	-	0.1	V
		I _O = 4.0 mA; V _{CC} = 4.5 V	-	-	0.33	V
		I _O = 5.2 mA; V _{CC} = 6.0 V	-	-	0.33	V
I _{LI}	input leakage current	V _I = V _{CC} or GND; V _{CC} = 6.0 V	-	-	1.0	μA
I _{CC}	quiescent supply current	V _I = V _{CC} or GND; I _O = 0 A; V _{CC} = 6.0 V	-	-	80.0	μA
T_{amb} = -40 °C to +125 °C						
V _{IH}	HIGH-level input voltage	V _{CC} = 2.0 V	1.5	-	-	V
		V _{CC} = 4.5 V	3.15	-	-	V
		V _{CC} = 6.0 V	4.2	-	-	V
V _{IL}	LOW-level input voltage	V _{CC} = 2.0 V	-	-	0.5	V
		V _{CC} = 4.5 V	-	-	1.35	V
		V _{CC} = 6.0 V	-	-	1.8	V

Table 7: Static characteristics for 74HC4040 ...continued

Voltages are referenced to GND (ground = 0 V).

Symbol	Parameter	Conditions	Min	Typ	Max	Unit
V _{OH}	HIGH-level output voltage	V _I = V _{IH} or V _{IL}				
		I _O = -20 μA; V _{CC} = 2.0 V	1.9	-	-	V
		I _O = -20 μA; V _{CC} = 4.5 V	4.4	-	-	V
		I _O = -20 μA; V _{CC} = 6.0 V	5.9	-	-	V
		I _O = -4.0 mA; V _{CC} = 4.5 V	3.7	-	-	V
V _{OL}	LOW-level output voltage	V _I = V _{IH} or V _{IL}				
		I _O = 20 μA; V _{CC} = 2.0 V	-	-	0.1	V
		I _O = 20 μA; V _{CC} = 4.5 V	-	-	0.1	V
		I _O = 20 μA; V _{CC} = 6.0 V	-	-	0.1	V
		I _O = 4.0 mA; V _{CC} = 4.5 V	-	-	0.4	V
I _{LI}	input leakage current	V _I = V _{CC} or GND; V _{CC} = 6.0 V	-	-	1.0	μA
			I _{CC}	quiescent supply current	V _I = V _{CC} or GND; I _O = 0 A; V _{CC} = 6.0 V	-

Table 8: Static characteristics for 74HCT4040

Voltages are referenced to GND (ground = 0 V).

Symbol	Parameter	Conditions	Min	Typ	Max	Unit	
T_{amb} = 25 °C							
V _{IH}	HIGH-level input voltage	V _{CC} = 4.5 V to 5.5 V	2.0	1.6	-	V	
V _{IL}	LOW-level input voltage	V _{CC} = 4.5 V to 5.5 V	-	1.2	0.8	V	
V _{OH}	HIGH-level output voltage	V _I = V _{IH} or V _{IL}					
		I _O = -20 μA; V _{CC} = 4.5 V	4.4	4.5	-	V	
V _{OL}	LOW-level output voltage	V _I = V _{IH} or V _{IL}	I _O = -4.0 mA; V _{CC} = 4.5 V	3.98	4.32	-	V
			I _O = 20 μA; V _{CC} = 4.5 V	-	0	0.1	V
V _{OL}	LOW-level output voltage	V _I = V _{IH} or V _{IL}	I _O = 4.0 mA; V _{CC} = 4.5 V	-	0.15	0.26	V
			I _{LI}	input leakage current	V _I = V _{CC} or GND; V _{CC} = 5.5 V	-	-
I _{CC}	quiescent supply current	V _I = V _{CC} or GND; I _O = 0 A; V _{CC} = 5.5 V	-	-	8.0	μA	
ΔI _{CC}	additional quiescent supply current	V _I = V _{CC} - 2.1 V; V _{CC} = 4.5 V to 5.5 V; I _O = 0 A					
			\overline{CP}	-	85	306	μA
			MR	-	110	396	μA
C _I	input capacitance		-	3.5	-	pF	
T_{amb} = -40 °C to +85 °C							
V _{IH}	HIGH-level input voltage	V _{CC} = 4.5 V to 5.5 V	2.0	-	-	V	
V _{IL}	LOW-level input voltage	V _{CC} = 4.5 V to 5.5 V	-	-	0.8	V	

Table 8: Static characteristics for 74HCT4040 ...continued

Voltages are referenced to GND (ground = 0 V).

Symbol	Parameter	Conditions	Min	Typ	Max	Unit
V _{OH}	HIGH-level output voltage	V _I = V _{IH} or V _{IL}				
		I _O = -20 µA; V _{CC} = 4.5 V	4.4	-	-	V
		I _O = -4.0 mA; V _{CC} = 4.5 V	3.84	-	-	V
V _{OL}	LOW-level output voltage	V _I = V _{IH} or V _{IL}				
		I _O = 20 µA; V _{CC} = 4.5 V	-	-	0.1	V
		I _O = 4.0 mA; V _{CC} = 4.5 V	-	-	0.33	V
I _{LI}	input leakage current	V _I = V _{CC} or GND; V _{CC} = 5.5 V	-	-	1.0	µA
I _{CC}	quiescent supply current	V _I = V _{CC} or GND; I _O = 0 A; V _{CC} = 5.5 V	-	-	80.0	µA
ΔI _{CC}	additional quiescent supply current	V _I = V _{CC} - 2.1 V; V _{CC} = 4.5 V to 5.5 V; I _O = 0 A				
		\overline{CP}	-	-	383	µA
		MR	-	-	495	µA
T_{amb} = -40 °C to +125 °C						
V _{IH}	HIGH-level input voltage	V _{CC} = 4.5 V to 5.5 V	2.0	-	-	V
V _{IL}	LOW-level input voltage	V _{CC} = 4.5 V to 5.5 V	-	-	0.8	V
V _{OH}	HIGH-level output voltage	V _I = V _{IH} or V _{IL}				
		I _O = -20 µA; V _{CC} = 4.5 V	4.4	-	-	V
		I _O = -4.0 mA; V _{CC} = 4.5 V	3.7	-	-	V
V _{OL}	LOW-level output voltage	V _I = V _{IH} or V _{IL}				
		I _O = 20 µA; V _{CC} = 4.5 V	-	-	0.1	V
		I _O = 4.0 mA; V _{CC} = 4.5 V	-	-	0.4	V
I _{LI}	input leakage current	V _I = V _{CC} or GND; V _{CC} = 5.5 V	-	-	1.0	µA
I _{CC}	quiescent supply current	V _I = V _{CC} or GND; I _O = 0 A; V _{CC} = 5.5 V	-	-	160.0	µA
ΔI _{CC}	additional quiescent supply current	V _I = V _{CC} - 2.1 V; V _{CC} = 4.5 V to 5.5 V; I _O = 0 A				
		\overline{CP}	-	-	417	µA
		MR	-	-	539	µA

12. Dynamic characteristics

Table 9: Dynamic characteristics for type 74HC4040

$GND = 0\text{ V}$; $t_r = t_f = 6\text{ ns}$. For test circuit see [Figure 9](#).

Symbol	Parameter	Conditions	Min	Typ	Max	Unit	
$T_{amb} = 25\text{ °C}$							
t_{PHL}, t_{PLH}	propagation delay \overline{CP} to Q_0	see Figure 8					
		$V_{CC} = 2.0\text{ V}$; $C_L = 50\text{ pF}$	-	47	150	ns	
		$V_{CC} = 4.5\text{ V}$; $C_L = 50\text{ pF}$	-	17	30	ns	
		$V_{CC} = 5.0\text{ V}$; $C_L = 15\text{ pF}$	-	14	-	ns	
	propagation delay Q_n to Q_{n+1}	see Figure 8					
		$V_{CC} = 2.0\text{ V}$; $C_L = 50\text{ pF}$	-	28	100	ns	
		$V_{CC} = 4.5\text{ V}$; $C_L = 50\text{ pF}$	-	10	20	ns	
		$V_{CC} = 5.0\text{ V}$; $C_L = 15\text{ pF}$	-	8	-	ns	
t_{PHL}	propagation delay MR to Q_n	see Figure 8					
		$V_{CC} = 2.0\text{ V}$; $C_L = 50\text{ pF}$	-	61	185	ns	
		$V_{CC} = 4.5\text{ V}$; $C_L = 50\text{ pF}$	-	22	37	ns	
		$V_{CC} = 6.0\text{ V}$; $C_L = 50\text{ pF}$	-	18	31	ns	
t_{THL}, t_{TLH}	output transition time	see Figure 8					
		$V_{CC} = 2.0\text{ V}$; $C_L = 50\text{ pF}$	-	19	75	ns	
		$V_{CC} = 4.5\text{ V}$; $C_L = 50\text{ pF}$	-	7	15	ns	
		$V_{CC} = 6.0\text{ V}$; $C_L = 50\text{ pF}$	-	6	13	ns	
t_w	clock pulse width HIGH or LOW	see Figure 8					
		$V_{CC} = 2.0\text{ V}$; $C_L = 50\text{ pF}$	80	14	-	ns	
		$V_{CC} = 4.5\text{ V}$; $C_L = 50\text{ pF}$	16	5	-	ns	
		$V_{CC} = 6.0\text{ V}$; $C_L = 50\text{ pF}$	14	4	-	ns	
	master reset pulse width; HIGH	see Figure 8					
		$V_{CC} = 2.0\text{ V}$; $C_L = 50\text{ pF}$	80	22	-	ns	
		$V_{CC} = 4.5\text{ V}$; $C_L = 50\text{ pF}$	16	8	-	ns	
		$V_{CC} = 6.0\text{ V}$; $C_L = 50\text{ pF}$	14	6	-	ns	
t_{rec}	recovery time MR to \overline{CP}	see Figure 8					
		$V_{CC} = 2.0\text{ V}$; $C_L = 50\text{ pF}$	50	8	-	ns	
		$V_{CC} = 4.5\text{ V}$; $C_L = 50\text{ pF}$	10	3	-	ns	
		$V_{CC} = 6.0\text{ V}$; $C_L = 50\text{ pF}$	9	2	-	ns	
f_{max}	maximum operating frequency	see Figure 8					
		$V_{CC} = 2.0\text{ V}$; $C_L = 50\text{ pF}$	6.0	27	-	MHz	
		$V_{CC} = 4.5\text{ V}$; $C_L = 50\text{ pF}$	30	82	-	MHz	
		$V_{CC} = 5.0\text{ V}$; $C_L = 15\text{ pF}$	-	90	-	MHz	
		$V_{CC} = 6.0\text{ V}$; $C_L = 50\text{ pF}$	35	98	-	MHz	
C_{PD}	power dissipation capacitance		-	20	-	pF	

Table 9: Dynamic characteristics for type 74HC4040 ...continued
GND = 0 V; $t_r = t_f = 6$ ns. For test circuit see Figure 9.

Symbol	Parameter	Conditions	Min	Typ	Max	Unit
$T_{amb} = -40$ °C to $+85$ °C						
t_{PHL} , t_{PLH}	propagation delay \overline{CP} to Q0	see Figure 8				
		$V_{CC} = 2.0$ V; $C_L = 50$ pF	-	-	190	ns
		$V_{CC} = 4.5$ V; $C_L = 50$ pF	-	-	38	ns
	propagation delay Qn to Qn+1	see Figure 8				
		$V_{CC} = 2.0$ V; $C_L = 50$ pF	-	-	125	ns
		$V_{CC} = 4.5$ V; $C_L = 50$ pF	-	-	25	ns
t_{PHL}	propagation delay MR to Qn	see Figure 8				
		$V_{CC} = 2.0$ V; $C_L = 50$ pF	-	-	230	ns
		$V_{CC} = 4.5$ V; $C_L = 50$ pF	-	-	46	ns
t_{THL} , t_{TLH}	output transition time	see Figure 8				
		$V_{CC} = 2.0$ V; $C_L = 50$ pF	-	-	95	ns
		$V_{CC} = 4.5$ V; $C_L = 50$ pF	-	-	19	ns
t_w	clock pulse width HIGH or LOW	see Figure 8				
		$V_{CC} = 2.0$ V; $C_L = 50$ pF	100	-	-	ns
		$V_{CC} = 4.5$ V; $C_L = 50$ pF	20	-	-	ns
	master reset pulse width; HIGH	see Figure 8				
		$V_{CC} = 2.0$ V; $C_L = 50$ pF	100	-	-	ns
		$V_{CC} = 4.5$ V; $C_L = 50$ pF	20	-	-	ns
t_{rec}	recovery time MR to \overline{CP}	see Figure 8				
		$V_{CC} = 2.0$ V; $C_L = 50$ pF	65	-	-	ns
		$V_{CC} = 4.5$ V; $C_L = 50$ pF	13	-	-	ns
f_{max}	maximum operating frequency	see Figure 8				
		$V_{CC} = 2.0$ V; $C_L = 50$ pF	4.8	-	-	MHz
		$V_{CC} = 4.5$ V; $C_L = 50$ pF	24	-	-	MHz
		$V_{CC} = 6.0$ V; $C_L = 50$ pF	28	-	-	MHz

Table 9: Dynamic characteristics for type 74HC4040 ...continued
GND = 0 V; $t_r = t_f = 6$ ns. For test circuit see Figure 9.

Symbol	Parameter	Conditions	Min	Typ	Max	Unit
$T_{amb} = -40$ °C to $+125$ °C						
t_{PHL} , t_{PLH}	propagation delay \overline{CP} to Q0	see Figure 8				
		$V_{CC} = 2.0$ V; $C_L = 50$ pF	-	-	225	ns
		$V_{CC} = 4.5$ V; $C_L = 50$ pF	-	-	45	ns
		$V_{CC} = 6.0$ V; $C_L = 50$ pF	-	-	38	ns
	propagation delay Qn to Qn+1	see Figure 8				
		$V_{CC} = 2.0$ V; $C_L = 50$ pF	-	-	150	ns
$V_{CC} = 4.5$ V; $C_L = 50$ pF		-	-	30	ns	
	$V_{CC} = 6.0$ V; $C_L = 50$ pF	-	-	26	ns	
t_{PHL}	propagation delay MR to Qn	see Figure 8				
		$V_{CC} = 2.0$ V; $C_L = 50$ pF	-	-	280	ns
		$V_{CC} = 4.5$ V; $C_L = 50$ pF	-	-	56	ns
		$V_{CC} = 6.0$ V; $C_L = 50$ pF	-	-	48	ns
t_{THL} , t_{TLH}	output transition time	see Figure 8				
		$V_{CC} = 2.0$ V; $C_L = 50$ pF	-	-	110	ns
		$V_{CC} = 4.5$ V; $C_L = 50$ pF	-	-	22	ns
		$V_{CC} = 6.0$ V; $C_L = 50$ pF	-	-	19	ns
t_w	clock pulse width HIGH or LOW	see Figure 8				
		$V_{CC} = 2.0$ V; $C_L = 50$ pF	120	-	-	ns
		$V_{CC} = 4.5$ V; $C_L = 50$ pF	24	-	-	ns
		$V_{CC} = 6.0$ V; $C_L = 50$ pF	20	-	-	ns
	master reset pulse width; HIGH	see Figure 8				
		$V_{CC} = 2.0$ V; $C_L = 50$ pF	120	-	-	ns
		$V_{CC} = 4.5$ V; $C_L = 50$ pF	24	-	-	ns
		$V_{CC} = 6.0$ V; $C_L = 50$ pF	20	-	-	ns
t_{rec}	recovery time MR to \overline{CP}	see Figure 8				
		$V_{CC} = 2.0$ V; $C_L = 50$ pF	75	-	-	ns
		$V_{CC} = 4.5$ V; $C_L = 50$ pF	15	-	-	ns
		$V_{CC} = 6.0$ V; $C_L = 50$ pF	13	-	-	ns
f_{max}	maximum operating frequency	see Figure 8				
		$V_{CC} = 2.0$ V; $C_L = 50$ pF	4.0	-	-	MHz
		$V_{CC} = 4.5$ V; $C_L = 50$ pF	20	-	-	MHz
		$V_{CC} = 6.0$ V; $C_L = 50$ pF	24	-	-	MHz

[1] C_{PD} is used to determine the dynamic power dissipation (P_D in μ W):

$$P_D = C_{PD} \times V_{CC}^2 \times f_i + \sum(C_L \times V_{CC}^2 \times f_o) \text{ where:}$$

f_i = input frequency in MHz;

f_o = output frequency in MHz;

$\sum(C_L \times V_{CC}^2 \times f_o)$ = sum of outputs;

C_L = output load capacitance in pF;

V_{CC} = supply voltage in V.

Table 10: Dynamic characteristics for type 74HCT4040

GND = 0 V; $t_r = t_f = 6$ ns. For test circuit see Figure 9.

Symbol	Parameter	Conditions	Min	Typ	Max	Unit
T_{amb} = 25 °C						
t _{PHL} , t _{PLH}	propagation delay \overline{CP} to Q0	see Figure 8				
		V _{CC} = 4.5 V; C _L = 50 pF	-	19	40	ns
		V _{CC} = 5.0 V; C _L = 15 pF	-	16	-	ns
	propagation delay Qn to Qn+1	see Figure 8				
		V _{CC} = 4.5 V; C _L = 50 pF	-	10	20	ns
		V _{CC} = 5.0 V; C _L = 15 pF	-	8	-	ns
t _{PHL}	propagation delay MR to Qn	V _{CC} = 4.5 V; C _L = 50 pF; see Figure 8;	-	23	45	ns
t _{THL} , t _{TLH}	output transition time	V _{CC} = 4.5 V; C _L = 50 pF; see Figure 8;	-	7	15	ns
t _w	clock pulse width HIGH or LOW	V _{CC} = 4.5 V; C _L = 50 pF; see Figure 8;	16	7	-	ns
	master reset pulse width; HIGH	V _{CC} = 4.5 V; C _L = 50 pF; see Figure 8;	16	6	-	ns
t _{rec}	recovery time MR to \overline{CP}	V _{CC} = 4.5 V; C _L = 50 pF; see Figure 8;	10	2	-	ns
f _{max}	maximum operating frequency	see Figure 8				
		V _{CC} = 4.5 V; C _L = 50 pF	30	72	-	MHz
		V _{CC} = 5.0 V; C _L = 15 pF	-	79	-	MHz
C _{PD}	power dissipation capacitance per package		[1] -	20	-	pF
T_{amb} = -40 °C to +85 °C						
t _{PHL} , t _{PLH}	propagation delay \overline{CP} to Q0	V _{CC} = 4.5 V; C _L = 50 pF; see Figure 8;	-	-	50	ns
	propagation delay Qn to Qn+1	V _{CC} = 4.5 V; C _L = 50 pF; see Figure 8;	-	-	25	ns
t _{PHL}	propagation delay MR to Qn	V _{CC} = 4.5 V; C _L = 50 pF; see Figure 8;	-	-	56	ns
t _{THL} , t _{TLH}	output transition time	V _{CC} = 4.5 V; C _L = 50 pF; see Figure 8;	-	-	19	ns
t _w	clock pulse width HIGH or LOW	V _{CC} = 4.5 V; C _L = 50 pF; see Figure 8;	20	-	-	ns
	master reset pulse width; HIGH	V _{CC} = 4.5 V; C _L = 50 pF; see Figure 8;	20	-	-	ns
t _{rec}	recovery time MR to \overline{CP}	V _{CC} = 4.5 V; C _L = 50 pF; see Figure 8;	13	-	-	ns
f _{max}	maximum operating frequency	V _{CC} = 4.5 V; C _L = 50 pF; see Figure 8;	24	-	-	MHz
T_{amb} = -40 °C to +125 °C						
t _{PHL} , t _{PLH}	propagation delay \overline{CP} to Q0	V _{CC} = 4.5 V; C _L = 50 pF; see Figure 8;	-	-	60	ns
	propagation delay Qn to Qn+1	V _{CC} = 4.5 V; C _L = 50 pF; see Figure 8;	-	-	30	ns

Table 10: Dynamic characteristics for type 74HCT4040 ...continued
GND = 0 V; $t_r = t_f = 6$ ns. For test circuit see Figure 9.

Symbol	Parameter	Conditions	Min	Typ	Max	Unit
t_{PHL}	propagation delay MR to Qn	$V_{CC} = 4.5$ V; $C_L = 50$ pF; see Figure 8	-	-	68	ns
t_{THL} , t_{TLH}	output transition time	$V_{CC} = 4.5$ V; $C_L = 50$ pF; see Figure 8	-	-	22	ns
t_W	clock pulse width HIGH or LOW	$V_{CC} = 4.5$ V; $C_L = 50$ pF; see Figure 8	24	-	-	ns
	master reset pulse width; HIGH	$V_{CC} = 4.5$ V; $C_L = 50$ pF; see Figure 8	24	-	-	ns
t_{rec}	recovery time MR to \overline{CP}	$V_{CC} = 4.5$ V; $C_L = 50$ pF; see Figure 8	15	-	-	ns
f_{max}	maximum operating frequency	$V_{CC} = 4.5$ V; $C_L = 50$ pF; see Figure 8	20	-	-	MHz

- [1] C_{PD} is used to determine the dynamic power dissipation (P_D in μ W):
 $P_D = C_{PD} \times V_{CC}^2 \times f_i + \sum(C_L \times V_{CC}^2 \times f_o)$ where:
 f_i = input frequency in MHz;
 f_o = output frequency in MHz;
 $\sum(C_L \times V_{CC}^2 \times f_o)$ = sum of outputs;
 C_L = output load capacitance in pF;
 V_{CC} = supply voltage in V.

13. Waveforms

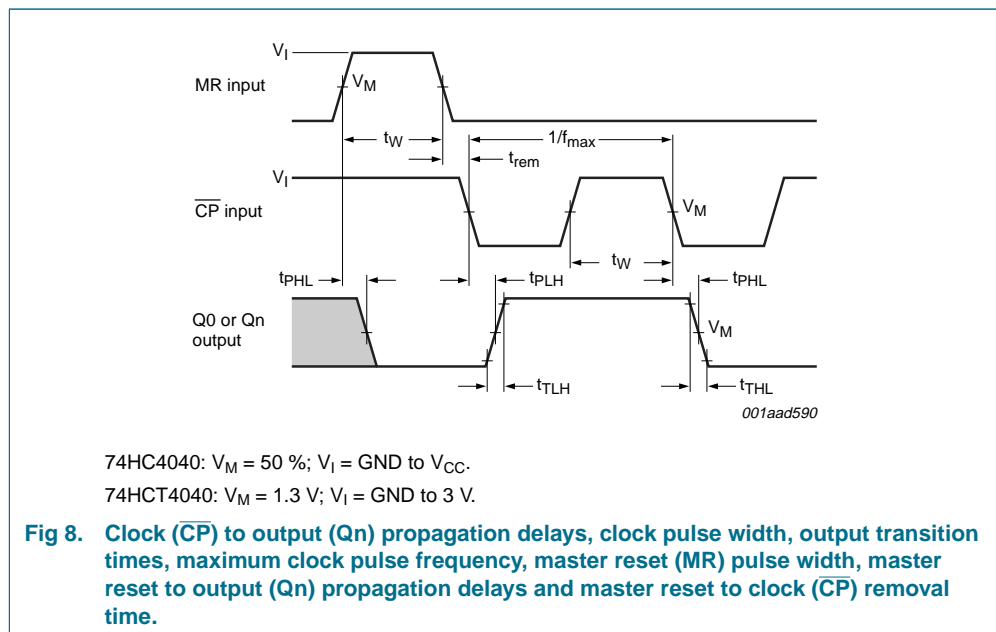

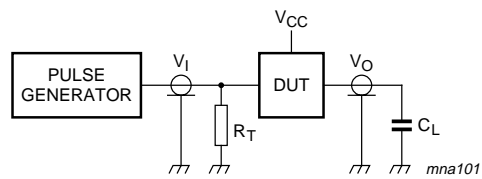

Definitions for test circuit:

C_L = load capacitance including jig and probe capacitance (See [Section 12](#) for the value).

R_T = termination resistance should be equal to output impedance Z_O of the pulse generator.

Fig 9. Test circuit

14. Package outline

DIP16: plastic dual in-line package; 16 leads (300 mil); long body

SOT38-1

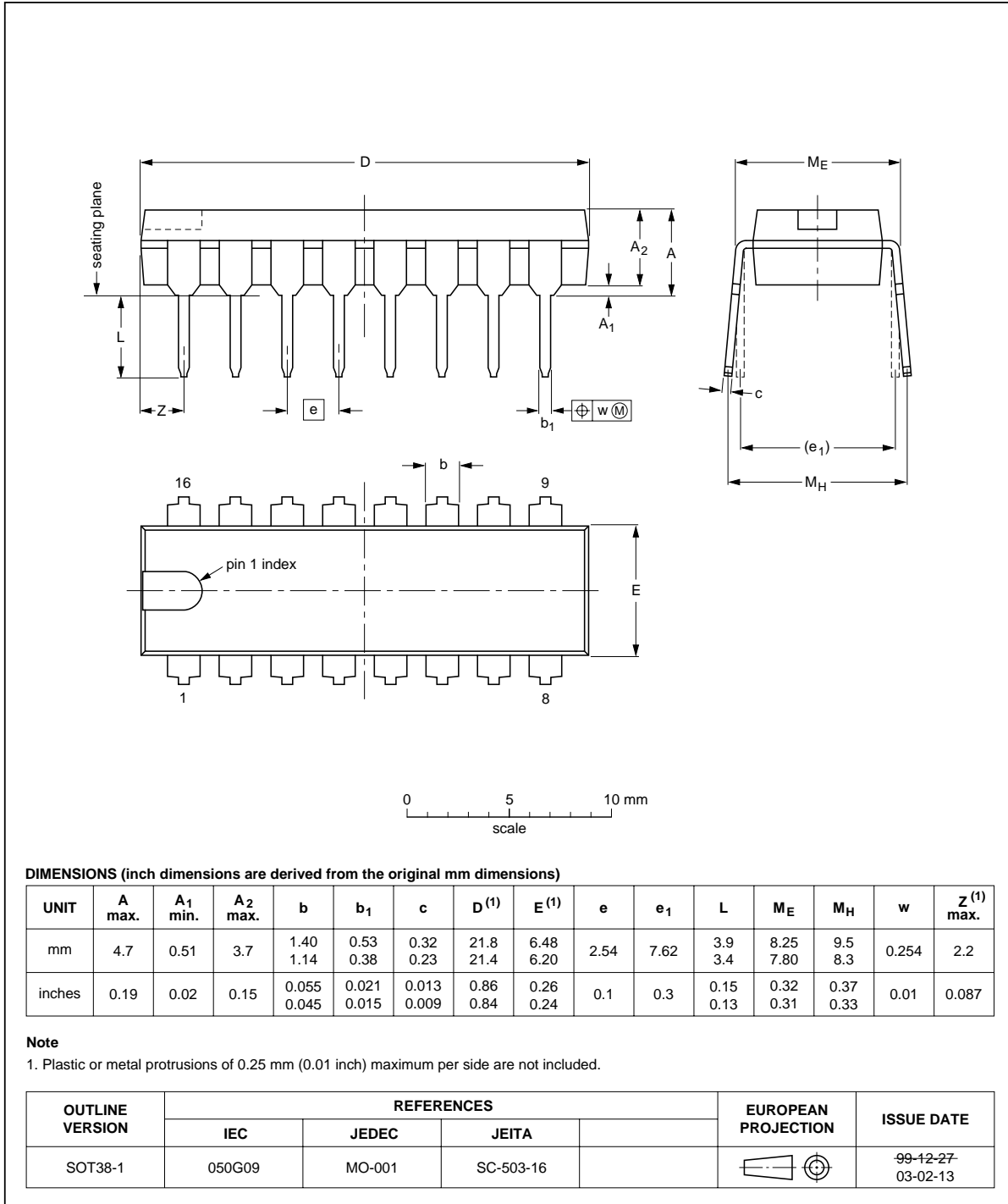

Fig 10. Package outline SOT38-1 (DIP16)

SO16: plastic small outline package; 16 leads; body width 3.9 mm

SOT109-1

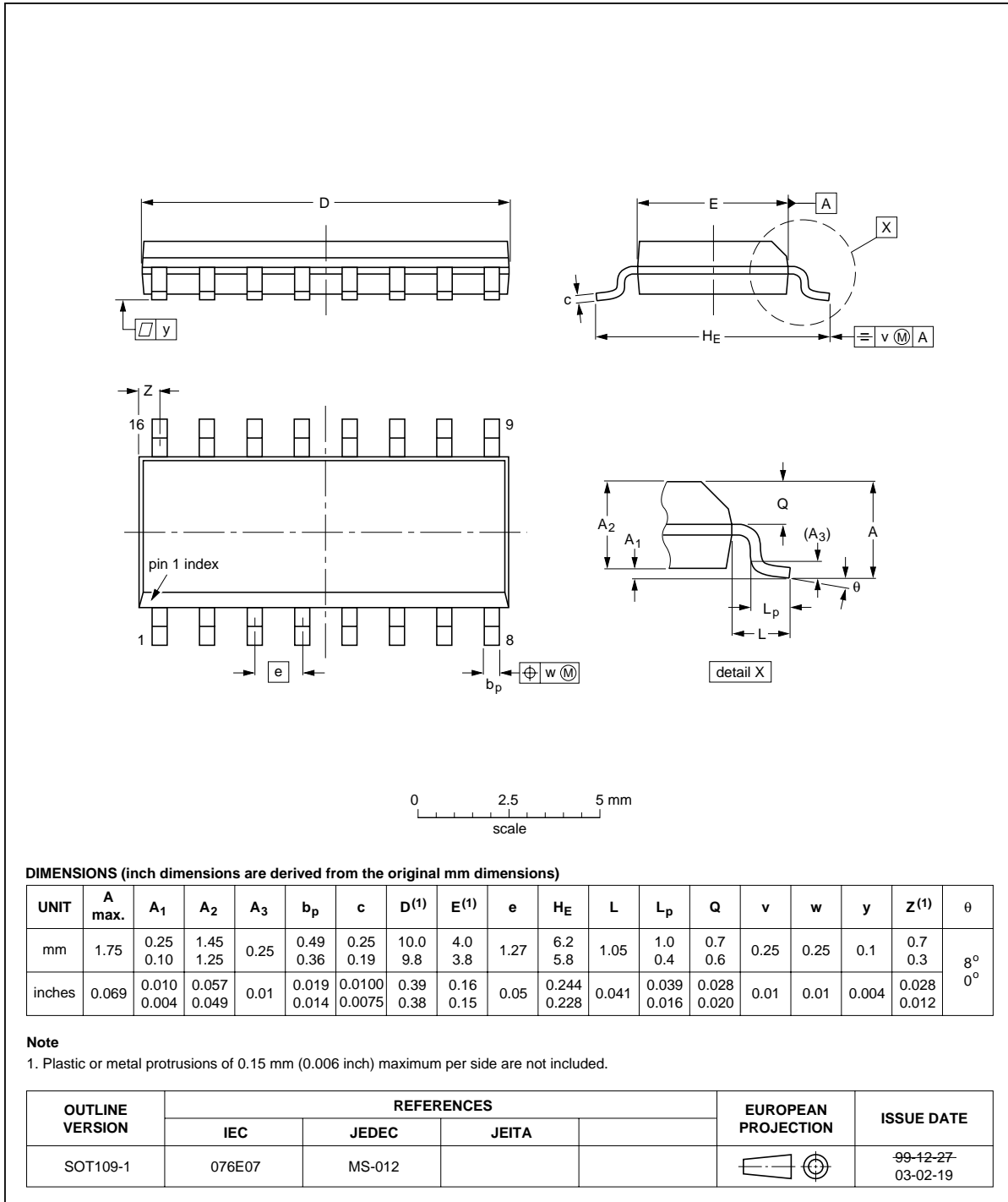

Fig 11. Package outline SOT109-1 (SO16)

SSOP16: plastic shrink small outline package; 16 leads; body width 5.3 mm

SOT338-1

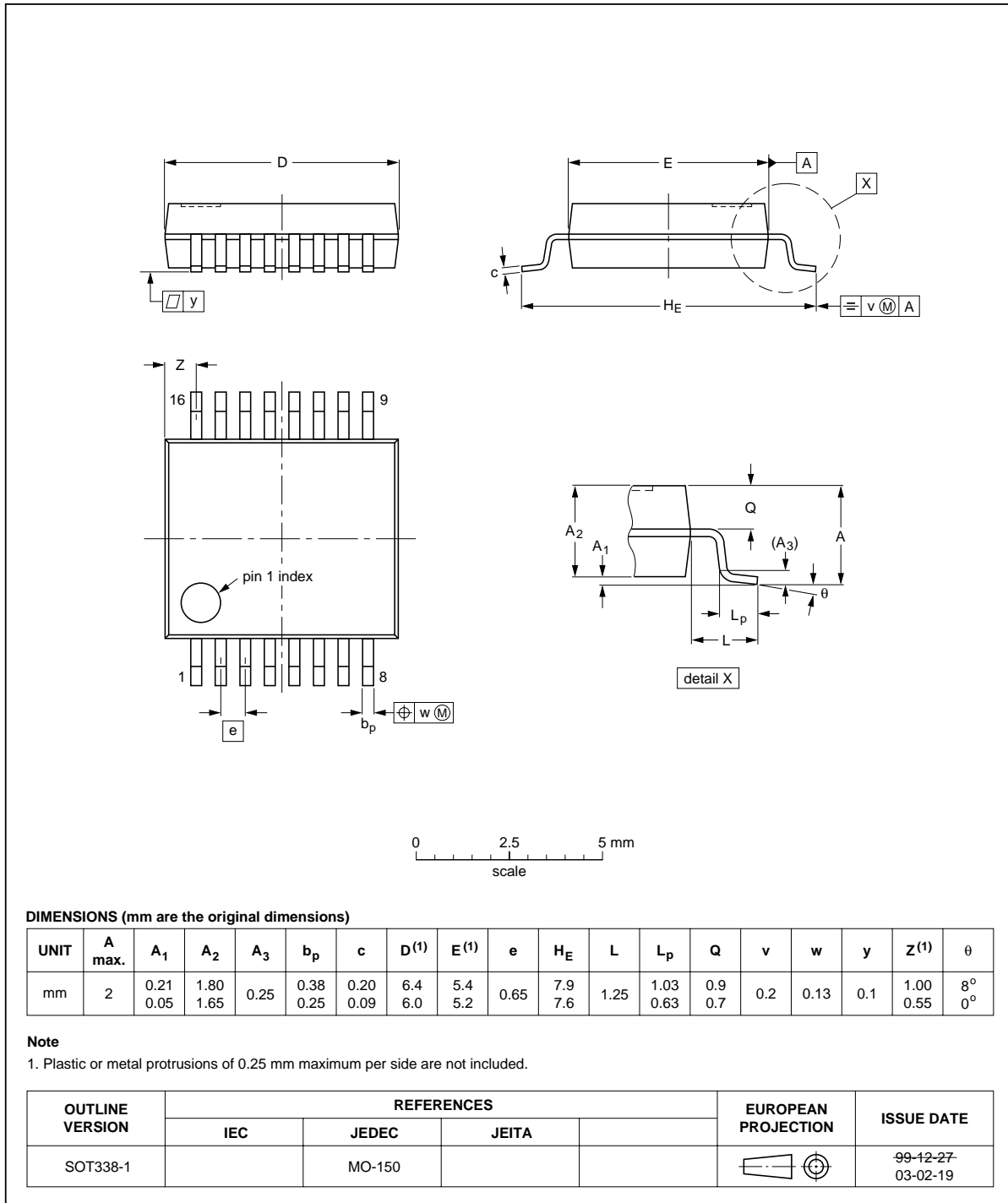

Fig 12. Package outline SOT338-1 (SSOP16)

TSSOP16: plastic thin shrink small outline package; 16 leads; body width 4.4 mm

SOT403-1

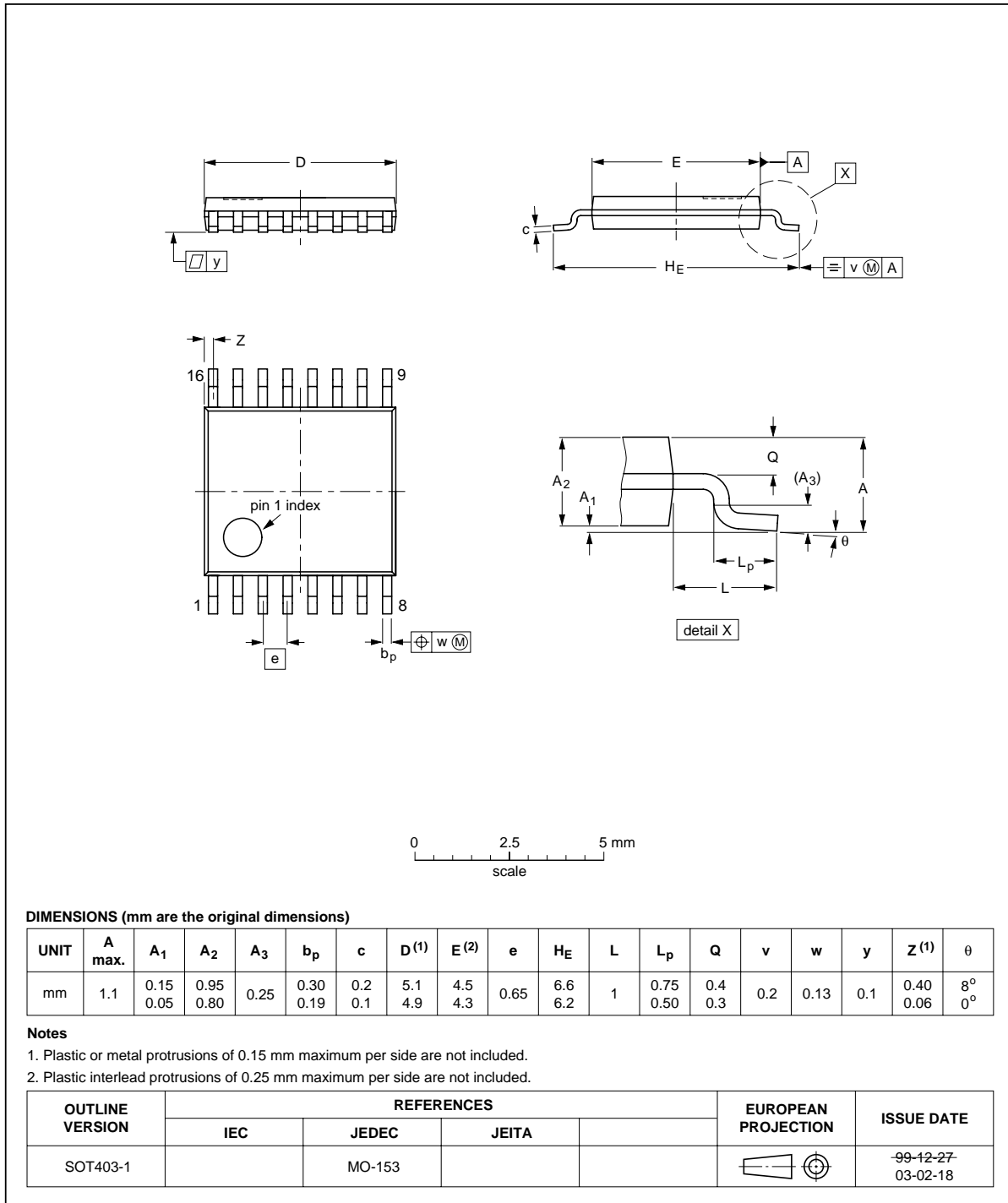

Fig 13. Package outline SOT403-1 (TSSOP16)

DHVQFN16: plastic dual in-line compatible thermal enhanced very thin quad flat package; no leads; 16 terminals; body 2.5 x 3.5 x 0.85 mm SOT763-1

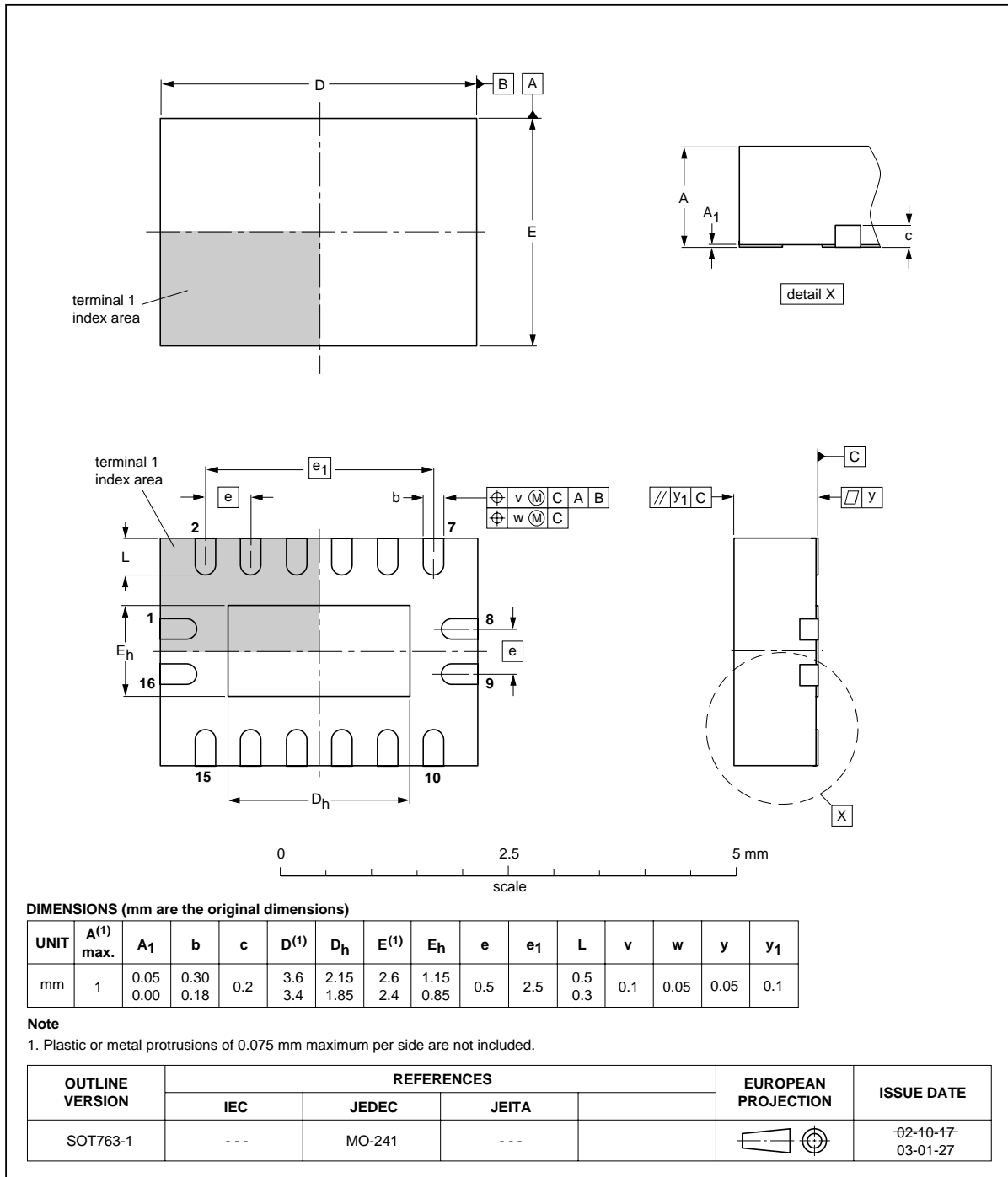

Fig 14. Package outline SOT763-1 (DHVQFN16)

15. Revision history

Table 11: Revision history

Document ID	Release date	Data sheet status	Change notice	Doc. number	Supersedes
74HC_HCT4040_3	20050914	Product data sheet	-	-	74HC_HCT4040_CNV_2
Modifications: <ul style="list-style-type: none"> • The format of this data sheet has been redesigned to comply with the new presentation and information standard of Philips Semiconductors • Reference to family specifications is replaced by the actual information: Section 5 "Ordering information", Section 7 "Pinning information", Section 9 "Limiting values", Section 10 "Recommended operating conditions", Section 11 "Static characteristics", Figure 9 "Test circuit" • Section 14 "Package outline" (DHVQFN16) added 					
74HC_HCT4040_CNV_2	19901231	Product specification	-	-	-

16. Data sheet status

Level	Data sheet status [1]	Product status [2] [3]	Definition
I	Objective data	Development	This data sheet contains data from the objective specification for product development. Philips Semiconductors reserves the right to change the specification in any manner without notice.
II	Preliminary data	Qualification	This data sheet contains data from the preliminary specification. Supplementary data will be published at a later date. Philips Semiconductors reserves the right to change the specification without notice, in order to improve the design and supply the best possible product.
III	Product data	Production	This data sheet contains data from the product specification. Philips Semiconductors reserves the right to make changes at any time in order to improve the design, manufacturing and supply. Relevant changes will be communicated via a Customer Product/Process Change Notification (CPCN).

[1] Please consult the most recently issued data sheet before initiating or completing a design.

[2] The product status of the device(s) described in this data sheet may have changed since this data sheet was published. The latest information is available on the Internet at URL <http://www.semiconductors.philips.com>.

[3] For data sheets describing multiple type numbers, the highest-level product status determines the data sheet status.

17. Definitions

Short-form specification — The data in a short-form specification is extracted from a full data sheet with the same type number and title. For detailed information see the relevant data sheet or data handbook.

Limiting values definition — Limiting values given are in accordance with the Absolute Maximum Rating System (IEC 60134). Stress above one or more of the limiting values may cause permanent damage to the device. These are stress ratings only and operation of the device at these or at any other conditions above those given in the Characteristics sections of the specification is not implied. Exposure to limiting values for extended periods may affect device reliability.

Application information — Applications that are described herein for any of these products are for illustrative purposes only. Philips Semiconductors make no representation or warranty that such applications will be suitable for the specified use without further testing or modification.

customers using or selling these products for use in such applications do so at their own risk and agree to fully indemnify Philips Semiconductors for any damages resulting from such application.

Right to make changes — Philips Semiconductors reserves the right to make changes in the products - including circuits, standard cells, and/or software - described or contained herein in order to improve design and/or performance. When the product is in full production (status 'Production'), relevant changes will be communicated via a Customer Product/Process Change Notification (CPCN). Philips Semiconductors assumes no responsibility or liability for the use of any of these products, conveys no license or title under any patent, copyright, or mask work right to these products, and makes no representations or warranties that these products are free from patent, copyright, or mask work right infringement, unless otherwise specified.

18. Disclaimers

Life support — These products are not designed for use in life support appliances, devices, or systems where malfunction of these products can reasonably be expected to result in personal injury. Philips Semiconductors

19. Trademarks

Notice — All referenced brands, product names, service names and trademarks are the property of their respective owners.

20. Contact information

For additional information, please visit: <http://www.semiconductors.philips.com>

For sales office addresses, send an email to: sales.addresses@www.semiconductors.philips.com

21. Contents

1	General description	1
2	Features	1
3	Applications	1
4	Quick reference data	1
5	Ordering information	2
6	Functional diagram	3
7	Pinning information	4
7.1	Pinning	4
7.2	Pin description	5
8	Functional description	5
8.1	Function table	5
8.2	Timing diagram	6
9	Limiting values	6
10	Recommended operating conditions	7
11	Static characteristics	7
12	Dynamic characteristics	11
13	Waveforms	15
14	Package outline	17
15	Revision history	22
16	Data sheet status	23
17	Definitions	23
18	Disclaimers	23
19	Trademarks	23
20	Contact information	23



© Koninklijke Philips Electronics N.V. 2005

All rights are reserved. Reproduction in whole or in part is prohibited without the prior written consent of the copyright owner. The information presented in this document does not form part of any quotation or contract, is believed to be accurate and reliable and may be changed without notice. No liability will be accepted by the publisher for any consequence of its use. Publication thereof does not convey nor imply any license under patent- or other industrial or intellectual property rights.

Date of release: 14 September 2005
Document number: 74HC_HCT4040_3

Published in The Netherlands