

# DATA SHEET

**74F640**

Octal bus transceiver, inverting (3-State)

Product specification

1989 Nov 27

IC15 Data Handbook

## Octal bus transceiver, inverting (3-State)

74F640

## FEATURES

- High-impedance NPN base inputs for reduced loading (70 $\mu$ A in High and Low states)
- Ideal for applications which require high-output drive and minimal bus loading
- Inverting version of 74F245
- Octal bidirectional bus interface
- 3-State outputs sink 64mA and source 15mA

## DESCRIPTION

The 74F640 is an octal transceiver featuring inverting 3-State bus compatible outputs in both transmit and receive directions. The B port outputs are capable of sinking 64mA and sourcing 15mA, providing very good capacitive drive characteristics. The device features an Output Enable ( $\overline{OE}$ ) input for easy cascading and Transmit/Receiver ( $T/\overline{R}$ ) input for direction control. The 3-State outputs, B0–B7, have been designed to prevent output bus loading if the power is removed from the device.

## PIN CONFIGURATION

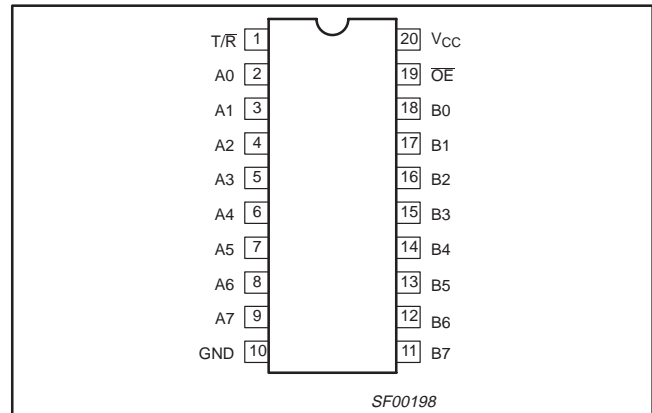

TYPE	TYPICAL PROPAGATION DELAY	TYPICAL SUPPLY CURRENT (TOTAL)
74F640	3.5ns	78mA

## ORDERING INFORMATION

DESCRIPTION	COMMERCIAL RANGE $V_{CC} = 5V \pm 10\%$ , $T_{amb} = 0^{\circ}C$ to $+70^{\circ}C$	PKG DWG #
20-pin plastic DIP	N74F640N	SOT146-1
20-pin plastic SOL	N74F640D	SOT163-1

## INPUT AND OUTPUT LOADING AND FAN-OUT TABLE

PINS	DESCRIPTION	74F(U.L.) HIGH/LOW	LOAD VALUE HIGH/LOW
A0 - A7, B0 - B7	Data inputs	3.5/0.115	70 $\mu$ A/70 $\mu$ A
$\overline{OE}$	Output Enable input (active Low)	2.0/0.067	40 $\mu$ A/40 $\mu$ A
$T/\overline{R}$	Transmit/Receive input	2.0/0.067	40 $\mu$ A/40 $\mu$ A
A0 - A7	A port outputs	150/40	3.0mA/24mA
B0 - B7	B port outputs	750/106.7	15mA/64mA

**NOTE:** One (1.0) FAST unit load is defined as: 20 $\mu$ A in the High state and 0.6mA in the Low state.

# Octal bus transceiver, inverting (3-State)

74F640

## LOGIC SYMBOL

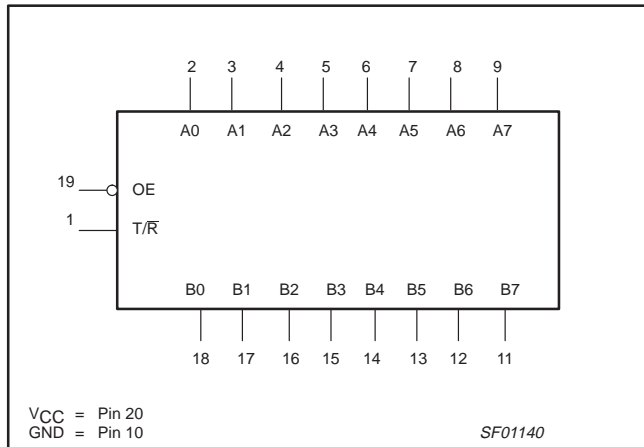

## LOGIC SYMBOL (IEEE/IEC)

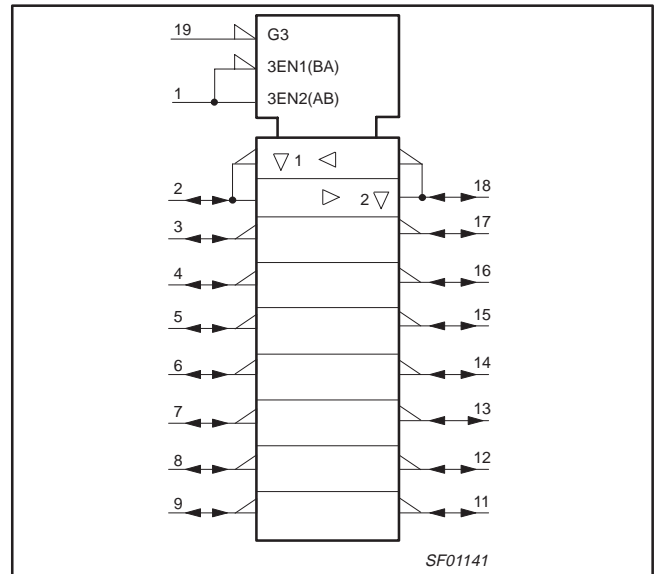

## FUNCTION TABLE

INPUTS		OUTPUTS
$\overline{OE}$	T/R	
L	L	Bus B data to Bus $\overline{A}$
L	H	Bus A data to Bus $\overline{B}$
H	X	Z

H = High voltage level  
 L = Low voltage level  
 X = Don't care  
 Z = High impedance "off" state

## LOGIC DIAGRAM

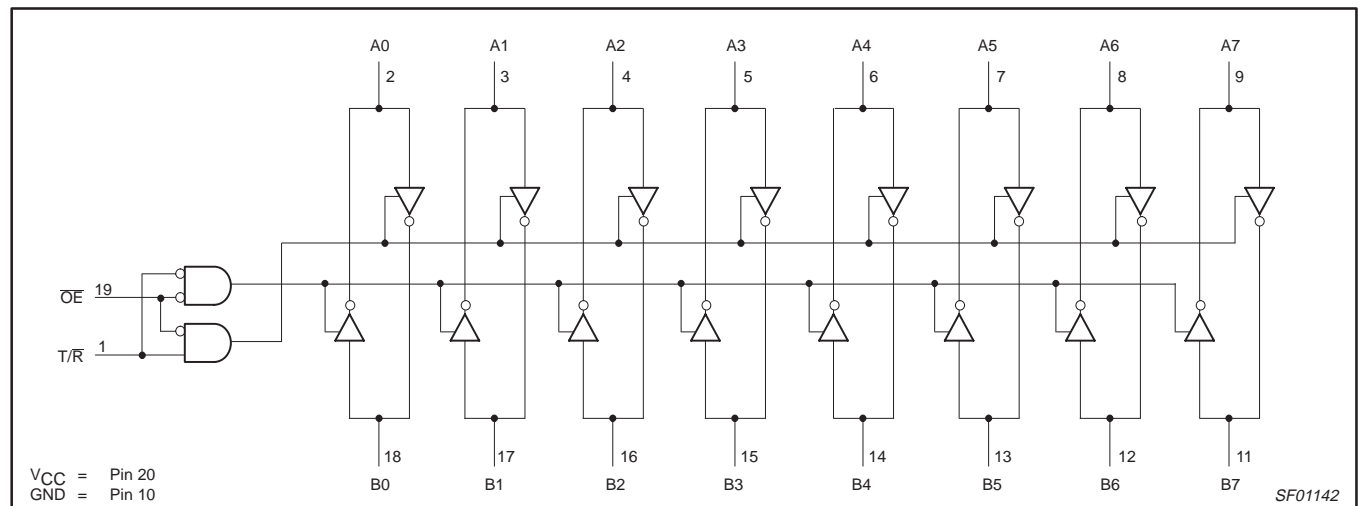

## Octal bus transceiver, inverting (3-State)

74F640

**ABSOLUTE MAXIMUM RATINGS**

(Operation beyond the limits set forth in this table may impair the useful life of the device.  
Unless otherwise noted these limits are over the operating free-air temperature range.)

SYMBOL	PARAMETER		RATING	UNIT
V <sub>CC</sub>	Supply voltage		-0.5 to +7.0	V
V <sub>IN</sub>	Input voltage		-0.5 to +7.0	V
I <sub>IN</sub>	Input current		-30 to +5	mA
V <sub>OUT</sub>	Voltage applied to output in High output state		-0.5 to +V <sub>CC</sub>	V
I <sub>OUT</sub>	Current applied to output in Low output state	A0-A7	48	mA
		B0-B7	128	mA
T <sub>amb</sub>	Operating free-air temperature range		0 to +70	°C
T <sub>stg</sub>	Storage temperature range		-65 to +150	°C

**RECOMMENDED OPERATING CONDITIONS**

SYMBOL	PARAMETER	LIMITS			UNIT
		MIN	NOM	MAX	
V <sub>CC</sub>	Supply voltage	4.5	5.0	5.5	V
V <sub>IH</sub>	High-level input voltage	2.0			V
V <sub>IL</sub>	Low-level input voltage			0.8	V
I <sub>IK</sub>	Input clamp current			-18	mA
I <sub>OH</sub>	High-level output current	A0-A7		-3	mA
		B0-B7		-15	mA
I <sub>OL</sub>	Low-level output current	A0-A7		24	mA
		B0-B7		64	mA
T <sub>amb</sub>	Operating free-air temperature range	0		70	°C

## Octal bus transceiver, inverting (3-State)

74F640

**DC ELECTRICAL CHARACTERISTICS**

(Over recommended operating free-air temperature range unless otherwise noted.)

SYMBOL	PARAMETER		TEST CONDITIONS <sup>NO TAG</sup>			LIMITS			UNIT
						MIN	TYP NO TAG	MAX	
V <sub>OH</sub>	High-level output voltage	A0–A7	V <sub>CC</sub> = MIN, V <sub>IL</sub> = MAX, V <sub>IH</sub> = MIN	I <sub>OH</sub> = –3mA	±10%V <sub>CC</sub>	2.4			V
		B0–B7			±5%V <sub>CC</sub>	2.7	3.3		V
		B0–B7		I <sub>OH</sub> = –15mA	±10%V <sub>CC</sub>	2.0			V
					±5%V <sub>CC</sub>	2.0			V
V <sub>OL</sub>	Low-level output voltage	A0–A7	V <sub>CC</sub> = MIN, V <sub>IL</sub> = MAX, V <sub>IH</sub> = MIN,	I <sub>OL</sub> = 24mA	±10%V <sub>CC</sub>		0.35	0.50	V
		B0–B7			±5%V <sub>CC</sub>		0.35	0.50	V
		B0–B7		I <sub>OL</sub> = MAX	±10%V <sub>CC</sub>			0.55	V
					±5%V <sub>CC</sub>		0.42	0.55	V
V <sub>IK</sub>	Input clamp voltage		V <sub>CC</sub> = MIN, I <sub>I</sub> = I <sub>IK</sub>			–0.73	–1.2	V	
I <sub>I</sub>	Input current at maximum input voltage	$\overline{OE}$ , T/R	V <sub>CC</sub> = 0.0V, V <sub>I</sub> = 7.0V				100	μA	
		A0–A7, B0–B7	V <sub>CC</sub> = 5.5V, V <sub>I</sub> = 5.5V				1.0	mA	
I <sub>IH</sub>	High-level input current	$\overline{OE}$ , T/R	V <sub>CC</sub> = MAX, V <sub>I</sub> = 2.7V				40	μA	
I <sub>IL</sub>	Low-level input current	only	V <sub>CC</sub> = MAX, V <sub>I</sub> = 0.5V				–40	μA	
I <sub>OZH</sub> +I <sub>IH</sub>	Off-state output current, High level of voltage applied		V <sub>CC</sub> = MAX, V <sub>I</sub> = 2.7V				70	μA	
I <sub>OZL</sub> +I <sub>IL</sub>	Off-state output current, Low level of voltage applied		V <sub>CC</sub> = MAX, V <sub>I</sub> = 0.5V				–70	μA	
I <sub>OS</sub>	Short-circuit output current <sup>NO TAG</sup>	A0–A7	V <sub>CC</sub> = MAX		–60		–150	mA	
		B0–B7			–100		–225	μA	
I <sub>CC</sub>	Supply current (total)	I <sub>CCH</sub>	V <sub>CC</sub> = MAX	T/R = A <sub>n</sub> = 4.5V, $\overline{OE}$ = GND		66	85	mA	
		I <sub>CCL</sub>		T/R = B <sub>n</sub> = $\overline{OE}$ = GND		91	120	mA	
		I <sub>CCZ</sub>		T/R = B <sub>n</sub> = GND, $\overline{OE}$ = 4.5V		78	102	mA	

**NOTES:**

- For conditions shown as MIN or MAX, use the appropriate value specified under recommended operating conditions for the applicable type.
- All typical values are at V<sub>CC</sub> = 5V, T<sub>amb</sub> = 25°C.
- Not more than one output should be shorted at a time. For testing I<sub>OS</sub>, the use of high-speed test apparatus and/or sample-and-hold techniques are preferable in order to minimize internal heating and more accurately reflect operational values. Otherwise, prolonged shorting of a High output may raise the chip temperature well above normal and thereby cause invalid readings in other parameter tests. In any sequence of parameter tests, I<sub>OS</sub> tests should be performed last.

Octal bus transceiver, inverting (3-State)

74F640

AC ELECTRICAL CHARACTERISTICS

SYMBOL	PARAMETER	TEST CONDITION	LIMITS					UNIT
			V <sub>CC</sub> = +5V T <sub>amb</sub> = +25°C C <sub>L</sub> = 50pF, R <sub>L</sub> = 500Ω			V <sub>CC</sub> = +5V ± 10% T <sub>amb</sub> = 0°C to +70°C C <sub>L</sub> = 50pF, R <sub>L</sub> = 500Ω		
			MIN	TYP	MAX	MIN	MAX	
t <sub>PLH</sub> t <sub>PHL</sub>	Propagation delay An to Bn, Bn to An	Waveform NO TAG	2.0 1.0	4.5 2.5	7.0 5.0	2.0 1.0	8.0 5.5	ns
t <sub>PZH</sub> t <sub>PZL</sub>	Output Enable time to High or Low level	Waveform 3 Waveform 2	5.5 5.5	6.5 7.0	10.5 10.5	5.0 5.0	12.0 11.0	ns
t <sub>PHZ</sub> t <sub>PLZ</sub>	Output Disable time from High or Low level	Waveform 3 Waveform 2	2.0 2.0	3.5 4.5	6.5 7.0	1.5 2.0	8.0 7.5	ns

# Octal bus transceiver, inverting (3-State)

74F640

## AC WAVEFORMS

For all waveforms,  $V_M = 1.5V$ .

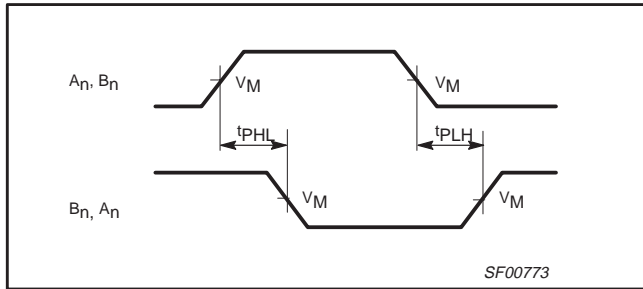

Waveform 1. Propagation Delay for Inverting Outputs

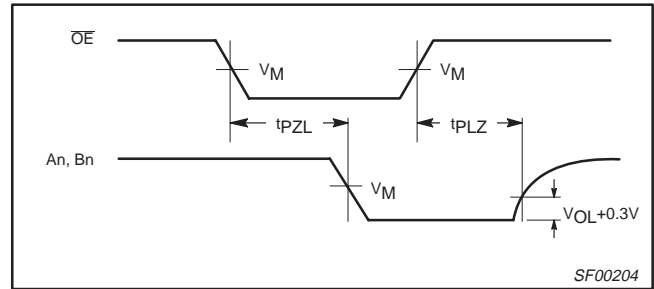

Waveform 2. 3-State Output Enable Time to Low Level and Output Disable Time from Low Level

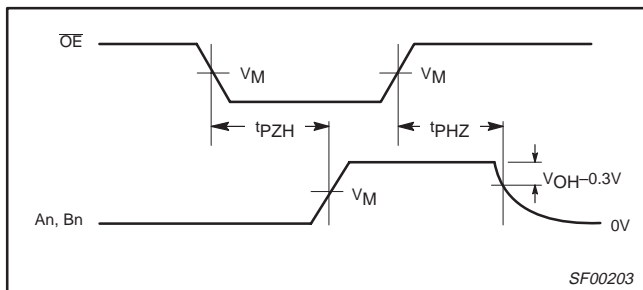

Waveform 3. 3-State Output Enable Time to High Level and Output Disable Time from High Level

## TEST CIRCUIT AND WAVEFORMS

**Test Circuit for Open Collector Outputs**

**SWITCH POSITION**

TEST	SWITCH
$t_{PLZ}$	closed
$t_{PZL}$	closed
All other	open

**DEFINITIONS:**  
 $R_L$  = Load resistor; see AC electrical characteristics for value.  
 $C_L$  = Load capacitance includes jig and probe capacitance; see AC electrical characteristics for value.  
 $R_T$  = Termination resistance should be equal to  $Z_{OUT}$  of pulse generators.

**Input Pulse Definition**

family	INPUT PULSE REQUIREMENTS					
	amplitude	$V_M$	rep. rate	$t_w$	$t_{TLH}$	$t_{THL}$
74F	3.0V	1.5V	1MHz	500ns	2.5ns	2.5ns

SF00128

# Octal bus transceiver, inverting (3-State)

## 74F640

**DIP20: plastic dual in-line package; 20 leads (300 mil)**

**SOT146-1**

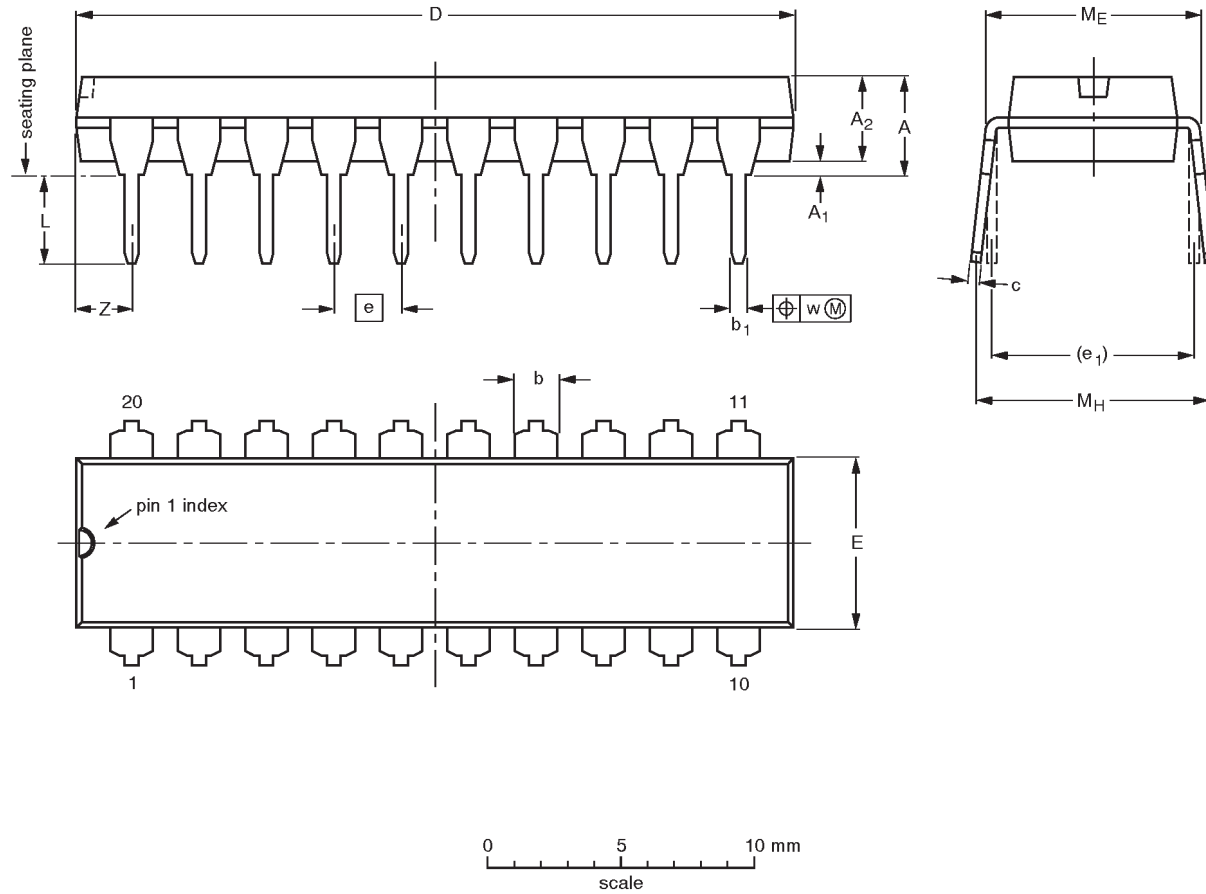

**DIMENSIONS (inch dimensions are derived from the original mm dimensions)**

UNIT	A max.	A <sub>1</sub> min.	A <sub>2</sub> max.	b	b <sub>1</sub>	c	D <sup>(1)</sup>	E <sup>(1)</sup>	e	e <sub>1</sub>	L	M <sub>E</sub>	M <sub>H</sub>	w	Z <sup>(1)</sup> max.
mm	4.2	0.51	3.2	1.73 1.30	0.53 0.38	0.36 0.23	26.92 26.54	6.40 6.22	2.54	7.62	3.60 3.05	8.25 7.80	10.0 8.3	0.254	2.0
inches	0.17	0.020	0.13	0.068 0.051	0.021 0.015	0.014 0.009	1.060 1.045	0.25 0.24	0.10	0.30	0.14 0.12	0.32 0.31	0.39 0.33	0.01	0.078

**Note**

1. Plastic or metal protrusions of 0.25 mm maximum per side are not included.

OUTLINE VERSION	REFERENCES				EUROPEAN PROJECTION	ISSUE DATE
	IEC	JEDEC	EIAJ			
SOT146-1			SC603			92-11-17 95-05-24



# Octal bus transceiver, inverting (3-State)

## 74F640

**SO20:** plastic small outline package; 20 leads; body width 7.5 mm

**SOT163-1**

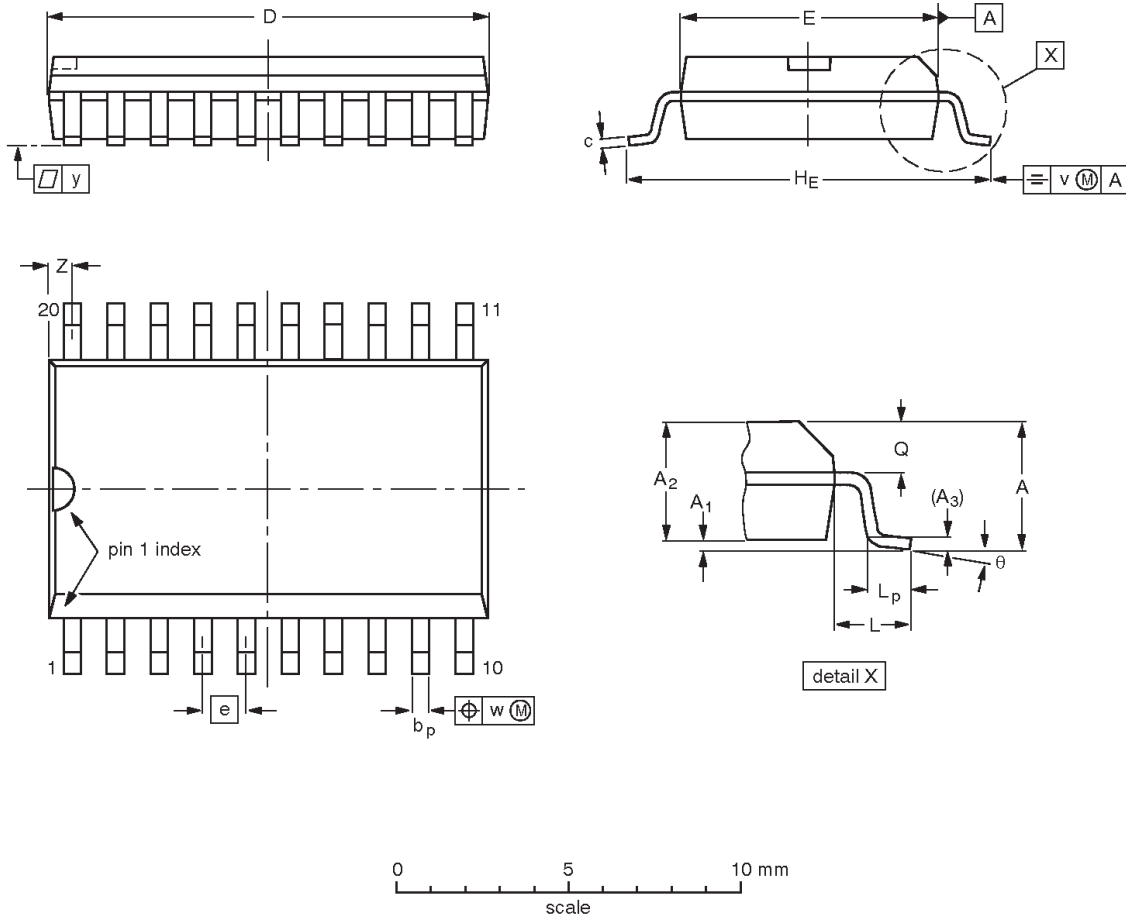

**DIMENSIONS (inch dimensions are derived from the original mm dimensions)**

UNIT	A max.	A <sub>1</sub>	A <sub>2</sub>	A <sub>3</sub>	b <sub>p</sub>	c	D <sup>(1)</sup>	E <sup>(1)</sup>	e	H <sub>E</sub>	L	L <sub>p</sub>	Q	v	w	y	z <sup>(1)</sup>	θ
mm	2.65	0.30 0.10	2.45 2.25	0.25	0.49 0.36	0.32 0.23	13.0 12.6	7.6 7.4	1.27	10.65 10.00	1.4	1.1 0.4	1.1 1.0	0.25	0.25	0.1	0.9 0.4	8° 0°
inches	0.10	0.012 0.004	0.096 0.089	0.01	0.019 0.014	0.013 0.009	0.51 0.49	0.30 0.29	0.050	0.419 0.394	0.055	0.043 0.016	0.043 0.039	0.01	0.01	0.004	0.035 0.016	

**Note**

1. Plastic or metal protrusions of 0.15 mm maximum per side are not included.

OUTLINE VERSION	REFERENCES				EUROPEAN PROJECTION	ISSUE DATE
	IEC	JEDEC	EIAJ			
SOT163-1	075E04	MS-013AC				95-01-24 97-05-22

---

Octal bus transceiver, inverting (3-State)

74F640

---

**NOTES**

## Octal bus transceiver, inverting (3-State)

74F640

## Data sheet status

Data sheet status	Product status	Definition [1]
Objective specification	Development	This data sheet contains the design target or goal specifications for product development. Specification may change in any manner without notice.
Preliminary specification	Qualification	This data sheet contains preliminary data, and supplementary data will be published at a later date. Philips Semiconductors reserves the right to make changes at any time without notice in order to improve design and supply the best possible product.
Product specification	Production	This data sheet contains final specifications. Philips Semiconductors reserves the right to make changes at any time without notice in order to improve design and supply the best possible product.

[1] Please consult the most recently issued datasheet before initiating or completing a design.

## Definitions

**Short-form specification** — The data in a short-form specification is extracted from a full data sheet with the same type number and title. For detailed information see the relevant data sheet or data handbook.

**Limiting values definition** — Limiting values given are in accordance with the Absolute Maximum Rating System (IEC 134). Stress above one or more of the limiting values may cause permanent damage to the device. These are stress ratings only and operation of the device at these or at any other conditions above those given in the Characteristics sections of the specification is not implied. Exposure to limiting values for extended periods may affect device reliability.

**Application information** — Applications that are described herein for any of these products are for illustrative purposes only. Philips Semiconductors make no representation or warranty that such applications will be suitable for the specified use without further testing or modification.

## Disclaimers

**Life support** — These products are not designed for use in life support appliances, devices or systems where malfunction of these products can reasonably be expected to result in personal injury. Philips Semiconductors customers using or selling these products for use in such applications do so at their own risk and agree to fully indemnify Philips Semiconductors for any damages resulting from such application.

**Right to make changes** — Philips Semiconductors reserves the right to make changes, without notice, in the products, including circuits, standard cells, and/or software, described or contained herein in order to improve design and/or performance. Philips Semiconductors assumes no responsibility or liability for the use of any of these products, conveys no license or title under any patent, copyright, or mask work right to these products, and makes no representations or warranties that these products are free from patent, copyright, or mask work right infringement, unless otherwise specified.

Philips Semiconductors  
811 East Arques Avenue  
P.O. Box 3409  
Sunnyvale, California 94088-3409  
Telephone 800-234-7381

© Copyright Philips Electronics North America Corporation 1998  
All rights reserved. Printed in U.S.A.

print code

Date of release: 10-98

Document order number:

9397-750-05148

*Let's make things better.*

Philips  
Semiconductors



**PHILIPS**