

**Features**

- The PT8A6301 works as the encoder and the PT8A6311 works as the decoder
- Supports three players in the same RF frequency
- CRC check
- On-chip oscillator with external ceramic crystal (6301) and external RC (6311)
- Provide clock output 125kHz
- Internal pull-up resistors for functional input pins
- Very low power supply voltage: 1.0V to 2.6V for PT8A6311
- Few external components needed

**General Description**

The PT8A6301/PT8A6311 provides a simple solution for three transmitters controlling three RC cars in TDMA mode. When 3 controllers transmit code signals, signal occurrence of the 3 players are interlaced in most time because space of adjacent 2 frames is different in 3 transmitters. In Rx section, each PT8A6311 can distinguish its own code signal according to channel ID. Finally the effective codes will be decoded and FORWARD, BACKWARD, RIGHT, LEFT, F1, F2 signals are sent out to drive external device. Additionally the PT8A6311 provides clock output for DC/DC or other function.

**Ordering Information**

Part No.	Package
PT8A6301W	16-Pin SOIC
PT8A6301P	14-Pin DIP
PT8A6301DE	Die Form
PT8A6311S	20-Pin SOIC
PT8A6311DE	Die Form

**Block Diagram**

Block Diagram of PT8A6301

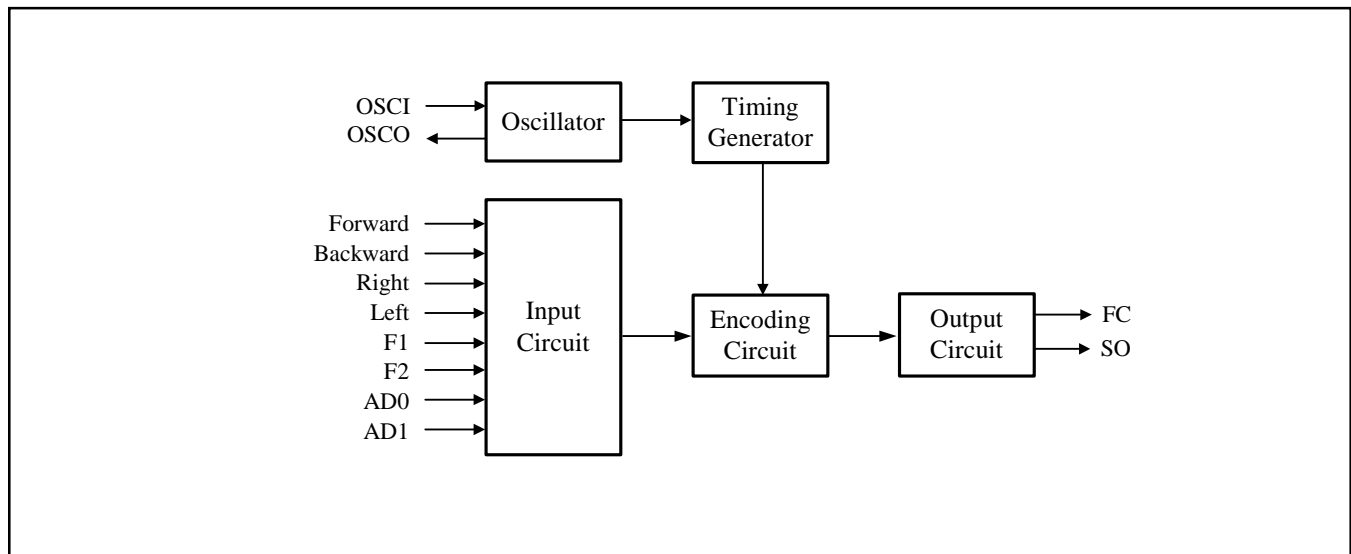

**Block Diagram of PT8A6311**

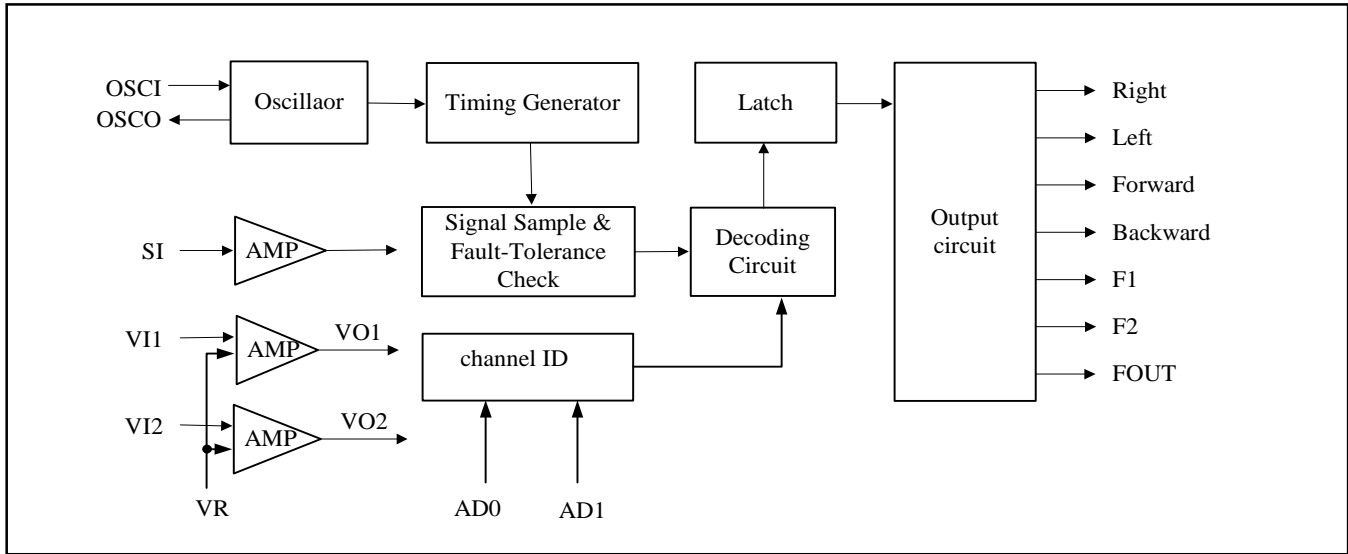

**Pad Location**

**Pad Location of PT8A6301**

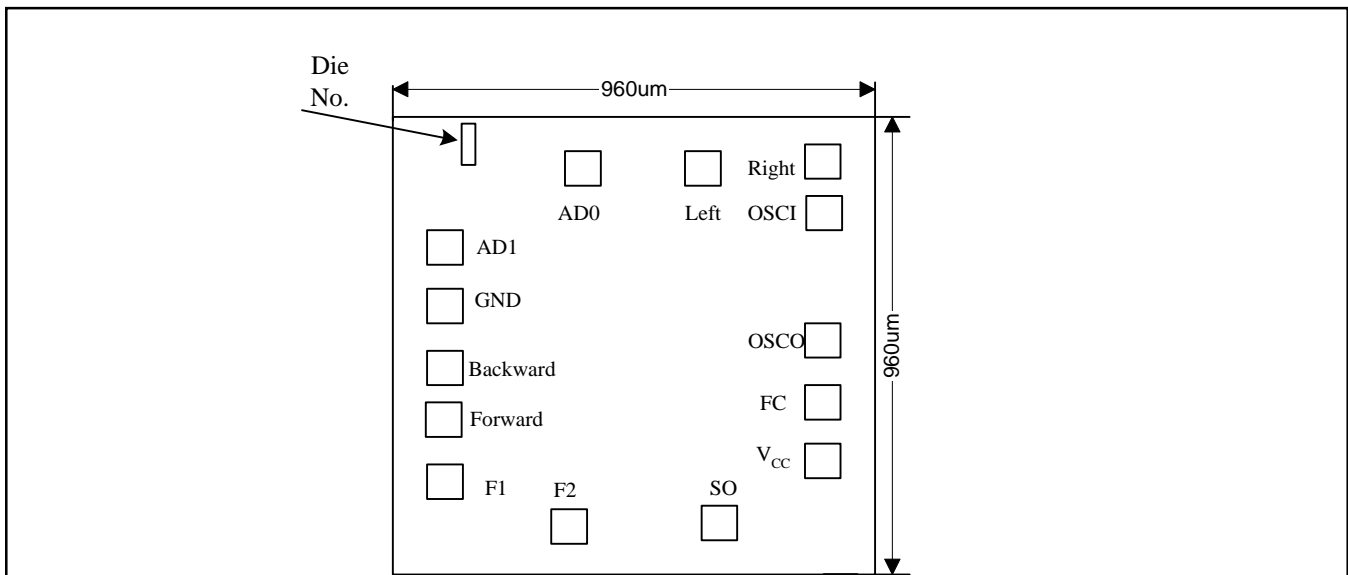

**Pad Coordinate**

Pad Name	X Coordinate	Y Coordinate	Pad Name	X Coordinate	Y Coordinate
AD0	-168.8	360.7	SO	150.8	-360.7
AD1	-331.8	201.7	V <sub>cc</sub>	331.8	-225.4
GND	-331.8	101.7	FC	331.8	-121.6
Backward	-331.8	0.3	OSCO	331.8	-21.6
Forward	-331.8	-103.5	OSCI	331.8	256.5
F1	-331.8	-203.5	Right	331.8	360.7
F2	-86.6	-360.7	Left	68.6	360.7

Note: Substrate is connected to GND

## Pin Configuration

### Pin Configuration of PT8A6301

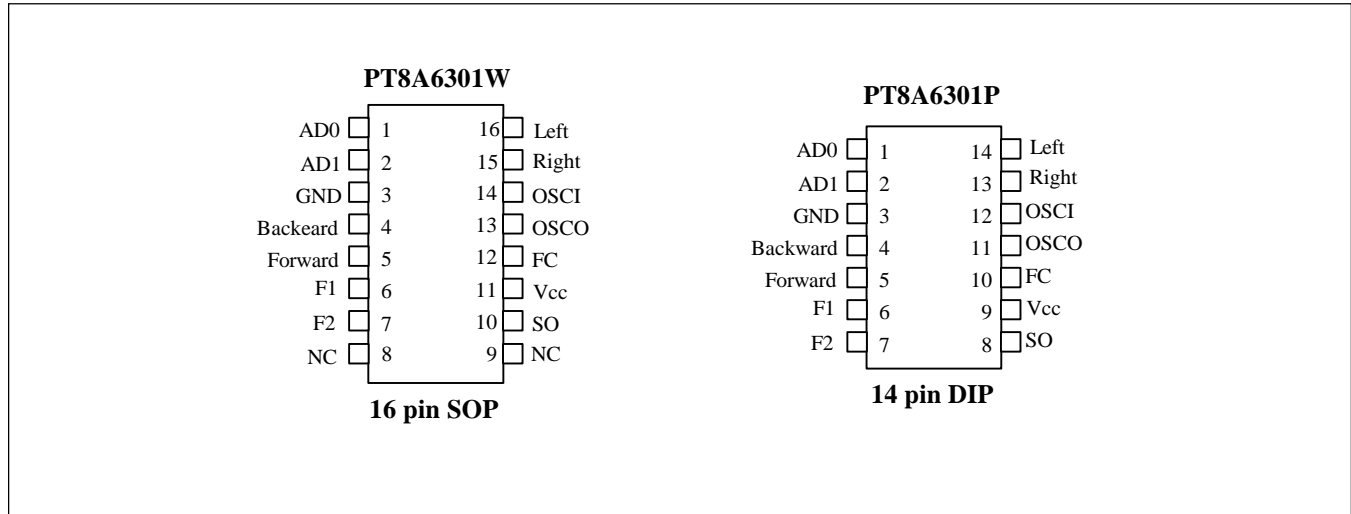

## Pin Description

### Pin Description of PT8A6301

Pin/Pad Name	Type	Description
AD0, AD1	I	Address pins: the two pins decide which channel will be selected, they are internally pulled down.
GND	GND	Ground
Backward	I	Backward function input, low active
Forward	I	Forward function input, low active
F1	I	Function 1 input, low active
F2	I	Function 2 input, low active
SO	O	Output pin of the encoding signa
V <sub>cc</sub>	P	Power supply
FC	O	Turn on/off 27MHz OSC
OSCO	O	Oscillator output pin
OSCI	I	Oscillator input pin
Right	I	Right function input, low active
Left	I	Left function input, low active

**Pad Location of PT8A6311**

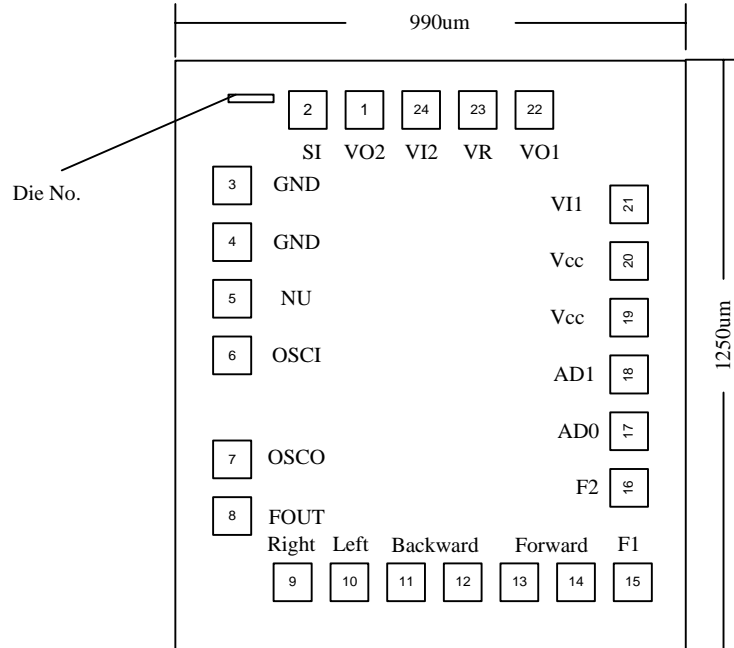

Pad Coordinate							
Pad No.	Pad Name	X Coordinate	Y Coordinate	Pad No.	Pad Name	X Coordinate	Y Coordinate
1	VO2	-90.2	480.5	13	Forward	151.8	-480.5
2	SI	-193.6	480.5	14	Forward	251.8	-480.5
3	GND	-348.5	389.2	15	F1	355.6	-480.5
4	GND	-348.5	289.2	16	F2	348.5	-261.2
5	NU	-348.5	186.5	17	AD0	348.5	-157
6	OSCI	-348.5	86.5	18	AD1	348.5	-57
7	OSCO	-348.5	-174	19	Vcc	348.5	46.4
8	FOUT	-348.5	-274	20	Vcc	348.5	146.4
9	Right	-255.8	-480.5	21	VI1	348.5	250.2
10	Left	-155.8	-480.5	22	VO1	217.4	480.5
11	Backward	-52	-480.5	23	VR	113.6	480.5
12	Backward	48	-480.5	24	VI2	13.6	480.5

Note: Substrate is connected to GND

**Pin Configuration of PT8A6311**

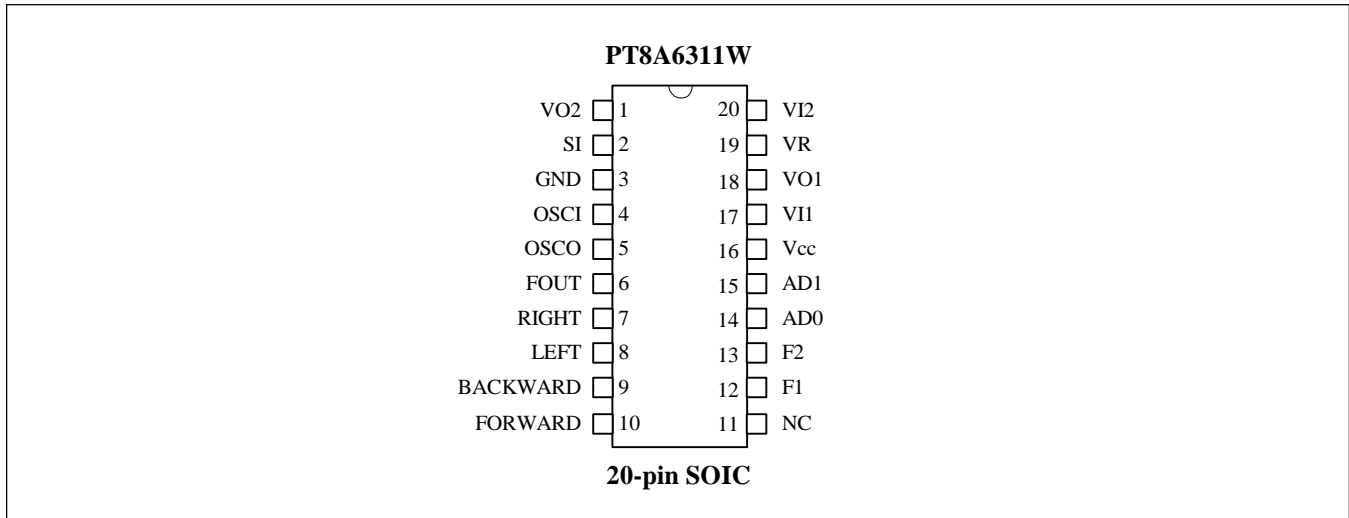

**Pin Description of PT8A6311**

Pin No	Pin/Pad Name	Type	Description
1	VO2	O	Output pins for the amplifier 2
2	SI	I	Input pin for encoded signal
3	GND	GND	Ground, bonded together
	NU	-	No used, must connected to GND
4	OSCI	I	Oscillator input pin
5	OSCO	O	Oscillator output pin
6	FOUT	O	Clock output, 125kHz square-wave output, 50% duty cycle
7	Right	O	Rightward output pin, active high
8	Left	O	Leftward output pin, active high
9	Backward	O	Backward output pins, the two pads should be bonded together, active low
10	Forward	O	Forward output pins, the two pads should be bonded together, active low
11	NC	-	No connection
12	F1	O	F1 function output pin, active high
13	F2	O	F2 function output pin, active high
14, 15	AD0, AD1	I	Address pins: the two pins decide which channel will be selected, they are internally pulled up
16	V <sub>cc</sub>	P	Power supply, bonded together
17	VI1	I	Input pins of amplifiers 1
18	VO1	O	Output pins for the amplifier 1
19	VR	I	DC offset input of input terminal for amplifier 1 and amplifier 2
20	VI2	I	Input pins of amplifiers 2

## Maximum Ratings

(Above which the useful life may be impaired. For user guidelines, not tested)

Storage Temperature .....	-25°C to +85°C
Ambient Temperature with Power Applied .....	0°C to +70°C
Supply Voltage to Ground Potential (Inputs & V <sub>CC</sub> Only) .....	-0.5 to +5.5V
Supply Voltage to Ground Potential (Outputs & D/O Only) ...	-0.5 to +5.5V
DC Input Voltage .....	-0.5 to +5.5V
DC Output Current .....	30mA
Power Dissipation .....	500mW

**Note:**

Stresses greater than those listed under MAXIMUM RATINGS may cause permanent damage to the device. This is a stress rating only and functional operation of the device at these or any other conditions above those indicated in the operational sections of this specification is not implied. Exposure to absolute maximum rating conditions for extended periods may affect reliability.

## Recommended Operation Conditions

Sym	Description	Min	Typ	Max	Units
V <sub>CC</sub>	Supply Voltage for PT8A6301	2.0	3.0	5.0	V
	Supply Voltage for PT8A6311	1.0	1.2	2.6	V
V <sub>IH</sub>	Input HIGH Voltage	0.7V <sub>CC</sub>	-	-	V
V <sub>IL</sub>	Input LOW Voltage	-	-	0.3V <sub>CC</sub>	V
f <sub>OSC</sub>	Oscillator Frequency (PT8A6301)	-	1	-	MHz
	Oscillator Frequency (PT8A6311)	-	125	-	kHz
T <sub>A</sub>	Operation Temperature	0	-	70	°C

## DC Electrical Characteristics

### DC Electrical Characteristics of PT8A6301

Sym	Description	Test Conditions	Min	Typ	Max	Units
V <sub>CC</sub>	Supply Voltage		2.0	3.0	5.0	V
I <sub>CC</sub>	Supply Current	Oscillator work, No load		400	500	A
I <sub>OH</sub>	Output HIGH Current - SO, FC	V <sub>CC</sub> = 2V, V <sub>OUT</sub> = V <sub>CC</sub> - 0.5V	-3	-5		mA
I <sub>OL</sub>	Output LOW Current - SO, FC	V <sub>CC</sub> = 2V, V <sub>OUT</sub> = 0.5V	2	3		mA
I <sub>IH</sub>	Input HIGH Current - function input pins	V <sub>IN</sub> = V <sub>CC</sub>			1	A
I <sub>IL</sub>	Input LOW Current - function input pins	V <sub>IN</sub> = 0V	-5	-10	-20	A
I <sub>IH1</sub>	Input HIGH Current- AD0, AD1	V <sub>IN</sub> = V <sub>CC</sub>	5	10	20	A
I <sub>IL1</sub>	Input LOW Current - AD0, AD1	V <sub>IN</sub> = 0V			-1	A

**Note:** These specifications apply for V<sub>CC</sub> = 3.0V and T<sub>A</sub> = 0°C to 70°C, unless otherwise specified.

**DC Electrical Characteristics of PT8A6311**

Sym	Description	Test Conditions	Min.	Type	Max.	Unit
V <sub>CC</sub>	Operating Voltage		1.0	1.2	2.6	V
I <sub>CC</sub>	Supply Current	Note 2	-	0.3	3.0	mA
I <sub>IL</sub>	Input Low Current for logic input pins	V <sub>in</sub> = 0		-10		uA
I <sub>IH</sub>	Input High Current for logic input pins	V <sub>in</sub> = V <sub>CC</sub>			1	uA
I <sub>OH1</sub>	Output High Current1 for FORWARD and BACKWARD pins	V <sub>out</sub> =V <sub>CC</sub> -0.2V	-150	-	-	uA
I <sub>OL1</sub>	Output Low Current1 for FORWARD and BACKWARD pins	V <sub>out</sub> =0.2V	4	-	-	mA
I <sub>OH2</sub>	Output High Current2 for LEFT ,RIGHT, F1 and F2 pins	V <sub>CC</sub> =1.0V V <sub>out</sub> =V <sub>CC</sub> -0.2V	-800	-	-	uA
I <sub>OL2</sub>	Output Low Current3 for LEFT ,RIGHT, F1 and F2 pins	V <sub>out</sub> =0.2V	150	600	-	uA
I <sub>OH3</sub>	Output High Current3 for FOUT	V <sub>CC</sub> =1.0V V <sub>out</sub> =V <sub>CC</sub> -0.2V	-800	-	-	uA
I <sub>OL3</sub>	Output Low Current3 for FOUT	V <sub>out</sub> =0.2V	800	-	-	uA
V <sub>OFF</sub>	Amplifier input offset voltage	V <sub>CC</sub> =1.0v		-	20	mv

**Note:**

1. Test conditions: V<sub>CC</sub> = 1.0 - 1.5V and T<sub>A</sub> = 0°C to 70°C, unless otherwise specified.
2. Feedback resistors for the two reversing amplifiers is 2.2MW and oscillator frequency is 125kHz.

**AC Electrical Characteristics**

Sym	Description	Test Conditions	Min	Typ	Max	Units
f <sub>OSC</sub>	Oscillator Frequency (PT8A6301)	-	-	1	-	MHz
	Oscillator Frequency (PT8A6311)	-	118	125	132	kHz
T <sub>d</sub>	The delay time between FC and SO(PT8T6301)	OSC frequency = 1MHz	-	6	-	ms
T <sub>AS</sub>	Auto-Stop Time*(PT8T6311)	OSC frequency =125kHz	-	-	800	ms
VSI	SI Pin Receive Sensitivity(PT8T6311)	Guaranteed effective decoding	40	-	100	mV

**Note:** Test conditions(PT8T6301): V<sub>CC</sub> = 3V, and T<sub>A</sub> = 0°C to 70°C, unless otherwise specified.

Test conditions(PT8T6311): V<sub>CC</sub> = 1.0 - 1.5V, and T<sub>A</sub> = 0°C to 70°C, unless otherwise specified.

\* Auto-stop time: if no effective signal received within the time, system will turn off all outputs automatically.

**Typical Application Circuit of PT8A6301**

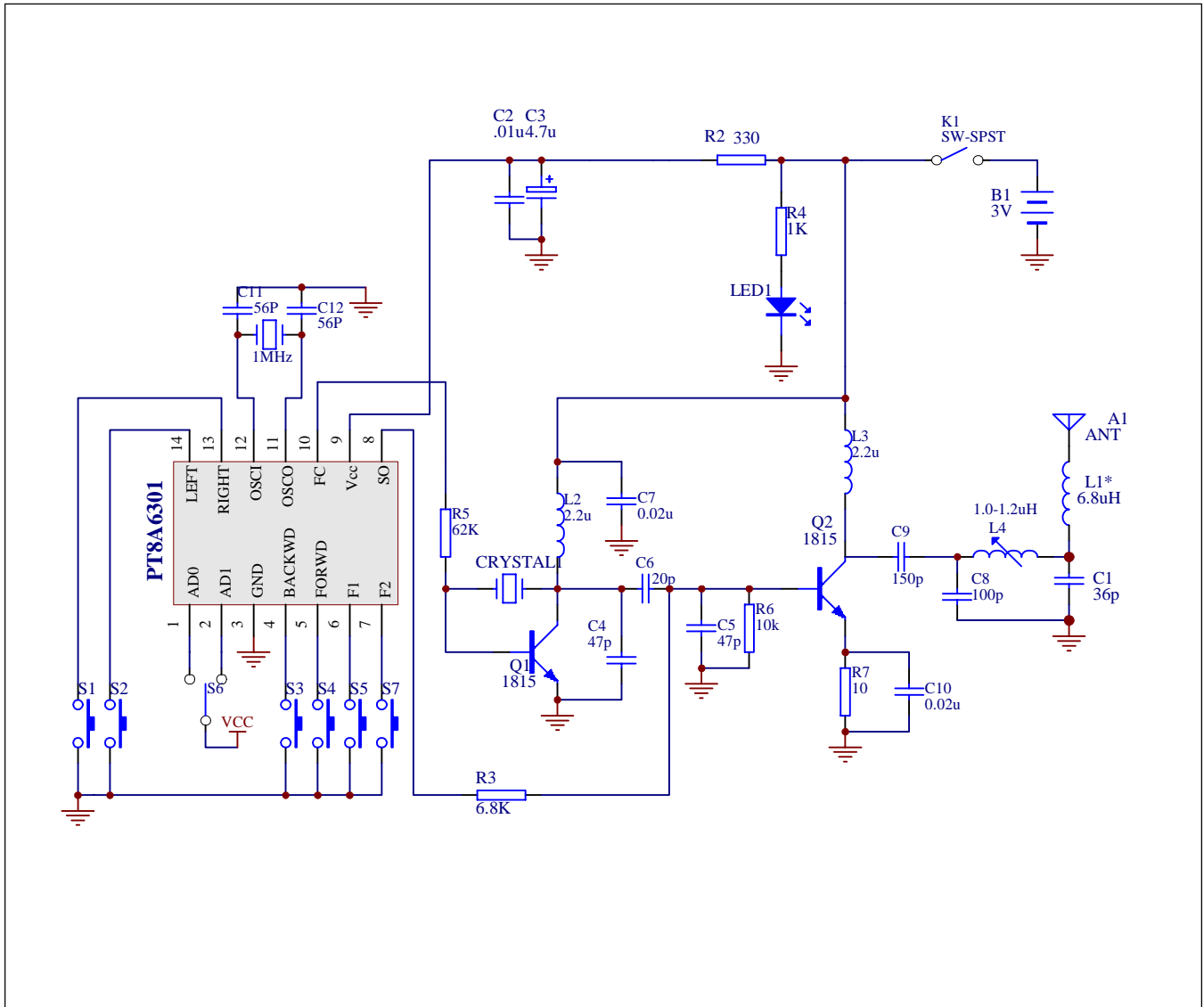



**Typical Application Circuit of PT8A6311**

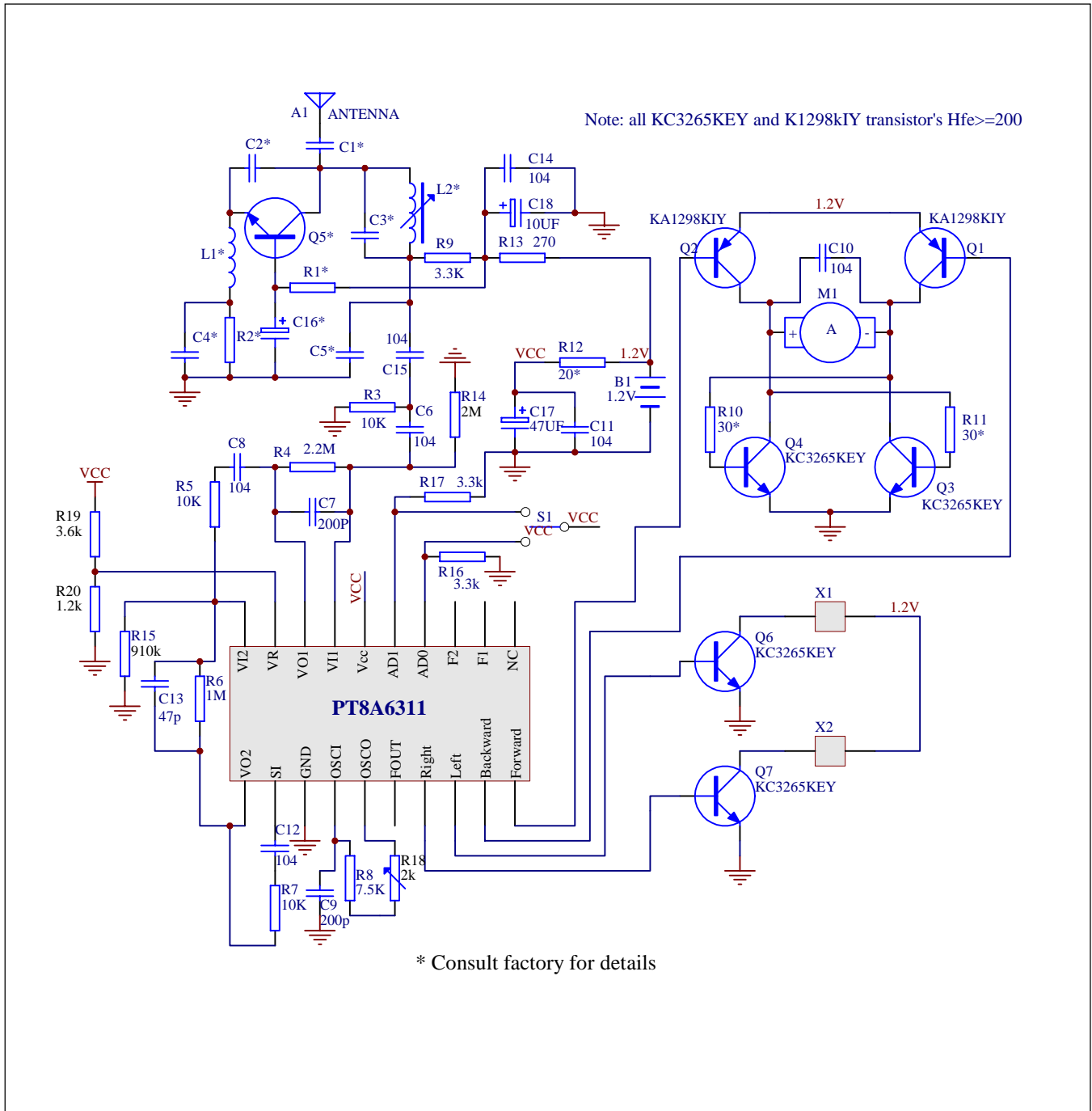

**Notes**

---

*Pericom Technology Inc.*

Email: support@pti.com.cn      Web Site: www.pti.com.cn, www.pti-ic.com

**China:**      No. 20 Building, 3/F, 481 Guiping Road, Shanghai, 200233, China  
Tel: (86)-21-6485 0576      Fax: (86)-21-6485 2181

**Asia Pacific:**      Unit 1517, 15/F, Chevalier Commercial Centre, 8 Wang Hoi Rd, Kowloon Bay, Hongkong  
Tel: (852)-2243 3660      Fax: (852)- 2243 3667

**U.S.A.:**      3545 North First Street, San Jose, California 95134, USA  
Tel: (1)-408-435 0800      Fax: (1)-408-435 1100

Pericom Technology Incorporation reserves the right to make changes to its products or specifications at any time, without notice, in order to improve design or performance and to supply the best possible product. Pericom Technology does not assume any responsibility for use of any circuitry described other than the circuitry embodied in Pericom Technology product. The company makes no representations that circuitry described herein is free from patent infringement or other rights, of Pericom Technology Incorporation.