



RoHS compliant

FEATURES

- **Small size and light weight**
For space saving, the outside dimensions of the main body are reduced to be 21.5 mm (length) × 14.4 mm (width) × 37 mm (height) (.846 × .567 × 1.457 inch) and the weight is also reduced to be approx. 19 g .67 oz (direct coupling 1 Form A, 1 Form B type)
- **Low operating power (1.4W) type is available (1 Form A, 1 Form B)**
- **Since the terminal arrangement complies with JIS D5011 B4-M1, commercial connectors are available for these types of relays.**
- **Superior inrush characteristics**
Despite its small size, 120A (max. 0.1 s) capacity has been achieved by using contacts that are good at withstanding inrush currents and because of an ingenious contacting mechanism. (1 Form A and 1 Form B)

TYPICAL APPLICATIONS

- **Motorcycles and automobiles**
Motorcycle cell motors, car air conditioners, halogen lamps, etc.
- **Agricultural equipment**
- **Battery equipped devices such as conveyance vehicles**

ORDERING INFORMATION

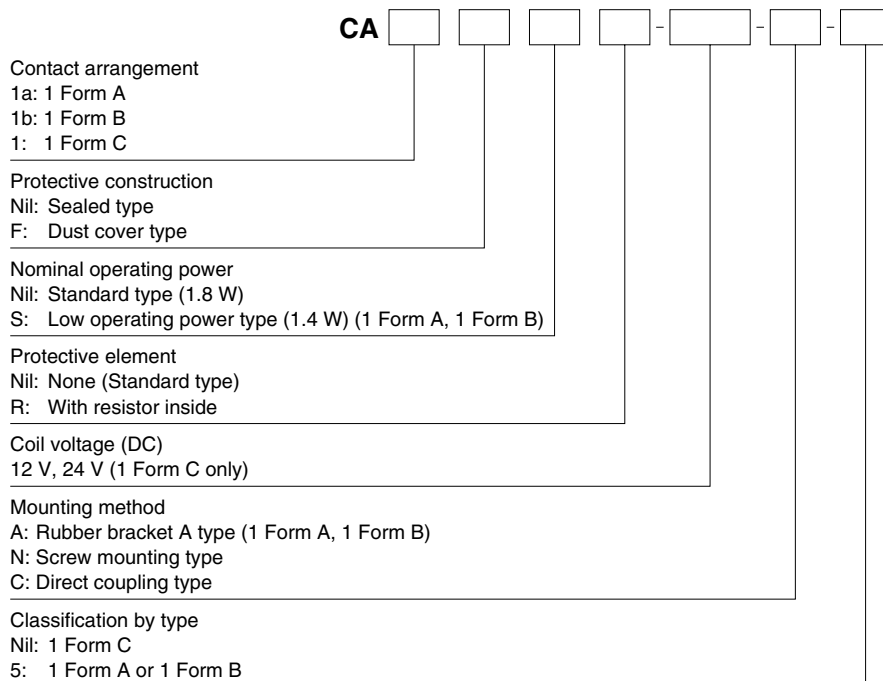

TYPES

Contact arrangement	Coil voltage	Mounting type	Standard type		Low operating power type	
			Sealed type	Dust cover type	Sealed type	Dust cover type
			Part No.	Part No.	Part No.	Part No.
1 Form A	12 V DC	Rubber bracket A	CA1a-12V-A-5	CA1aF-12V-A-5	CA1aS-12V-A-5	CA1aFS-12V-A-5
		Screw-mounting	CA1a-12V-N-5	CA1aF-12V-N-5	CA1aS-12V-N-5	CA1aFS-12V-N-5
		Direct coupling	CA1a-12V-C-5	CA1aF-12V-C-5	CA1aS-12V-C-5	CA1aFS-12V-C-5
1 Form B	12 V DC	Rubber bracket A	CA1b-12V-A-5	CA1bF-12V-A-5	CA1bS-12V-A-5	CA1bFS-12V-A-5
		Screw-mounting	CA1b-12V-N-5	CA1bF-12V-N-5	CA1bS-12V-N-5	CA1bFS-12V-N-5
		Direct coupling	CA1b-12V-C-5	CA1bF-12V-C-5	CA1bS-12V-C-5	CA1bFS-12V-C-5
1 Form C	12 V DC	Screw-mounting	CA1-12V-N	-	-	-
		Direct coupling	CA1-12V-C	-	-	-
	24 V DC	Screw-mounting	CA1-24V-N	-	-	-
		Direct coupling	CA1-24V-C	-	-	-

Standard packing: Carton: 20 pcs. Case: 200 pcs.

Note: Please use "CA**R-***" or CA**SR-***" built-in resistor type. (Asterisks "*" should be filled in from ORDERING INFORMATION.)

RATING

1. Coil data

	Nominal coil voltage	Pick-up voltage (at 20°C 68°F)	Drop-out voltage (at 20°C 68°F)	Nominal operating current [±10%] (at 20°C 68°F)	Coil resistance [±10%] (at 20°C 68°F)	Nominal operating power	Usable voltage range
Standard type 1 Form A and 1 Form B	12 V DC	Max. 8 V DC	0.6 to 6 V DC	150 mA	80Ω	1.8 W	10 to 16V DC
Low operating power type 1 Form A and 1 Form B	12 V DC	Max. 8 V DC	0.6 to 6 V DC	120 mA	100Ω	1.4 W	10 to 16V DC
1 Form C	12 V DC	Max. 8 V DC	Min. 0.6 V DC	150 mA	80Ω	1.8 W	10 to 15V DC
	24 V DC	Max. 16 V DC	Min. 1.2 V DC	75 mA	320Ω	1.8 W	20 to 30V DC

Note: Other pick-up voltage types are also available. Please contact us for details.

2. Specifications

1) 12 V DC type

Characteristics	Item	Specifications		
		1 Form A type	1 Form B type	1 Form C type
Contact	Arrangement	1 Form A		
	Contact resistance (Initial)	Typ 3mΩ (By voltage drop 6V DC 1A)		
	Contact voltage drop	Max. 0.3 V [(after electrical life test, by voltage drop 12 V DC 20 A (1.4 W type), 12 V DC 30 A (1.8 W type)]	Max. 0.3 V (after electrical life test, by voltage drop 12 V DC 20 A)	Max. 0.4 V (after electrical life test, by voltage drop 12 V DC 20 A)
	Contact material	Ag alloy (Cadmium free)		
Rating	Nominal switching capacity (resistive load)	20 A 12V DC (1.4 W type) 30 A 12V DC (1.8 W type)	20 A 12 V DC	
	Max. carrying current (at coil applied voltage 14 V DC, 80°C 176°F)	20 A continuous (1.4 W type) 30 A for 1 min. (1.8 W type)	20 A continuous	20 A continuous
	Nominal operating power	1.4 W/1.8 W		1.8 W
	Min. switching capacity (resistive load)*1	1 A 12V DC		
Electrical characteristics	Insulation resistance (Initial)	Min. 10 MΩ (at 500V DC)		Min. 10 MΩ (at 500V DC)
	Breakdown voltage (Initial)	Between open contacts	500 Vrms for 1 min. (Detection current: 10mA)	
		Between contacts and coil	500 Vrms for 1 min. (Detection current: 10mA)	
	Operate time (at 20°C 68°F)	Max. 10ms (at nominal voltage) (excluding contact bounce time) (Initial)		
Release time (at 20°C 68°F)	Max. 10ms (at nominal voltage) (excluding contact bounce time) (Initial)			
Mechanical characteristics	Shock resistance	Functional	Min. 200 m/s ² {20G} (Half-wave pulse of sine wave: 11ms; detection time: 10μs)	Min. 100 m/s ² {10G} (Half-wave pulse of sine wave: 11ms; detection time: 10μs)
		Destructive	Min. 1,000 m/s ² {100G} (Half-wave pulse of sine wave: 6ms)	
	Vibration resistance	Functional	Rubber bracket A type: 50 Hz to 500 Hz, Min. 100 m/s ² {10G} Screw-mounting and direct coupling type: 33 Hz, Min. 44.1 m/s ² {4.5G} (Detection time: 10μs)	
		Destructive	Rubber bracket A type: 50 Hz to 500 Hz, Min. 100 m/s ² {10G} Screw-mounting and direct coupling type: 33 Hz, Min. 44.1 m/s ² {4.5G}, Time of vibration for each direction; X, Y direction: 2 hours, Z direction: 4 hours	
Expected life	Electrical (at nominal switching capacity)	Min. 10 ⁵ (operating frequency: 2s ON, 2s OFF) (1.4 W and 1.8 W type at 20 A) Min. 2 × 10 ⁴ (operating frequency: 3s ON, 15s OFF) (1.8 W type at 30 A)	Min. 10 ⁵ (operating frequency: 2s ON, 2s OFF)	
	Mechanical	Min. 10 ⁶ (at 120 cpm)		Min. 5 × 10 ⁵ (at 120 cpm)
Conditions	Conditions for operation, transport and storage*2	Ambient temperature: -30°C to +80°C -22°F to +176°F, Humidity: 5% R.H. to 85% R.H. (Not freezing and condensing at low temperature)		
	Max. operating speed	15 cpm (1.4 W type: at nominal load, 1.8 W type: at 20 A)	15 cpm (at nominal switching capacity)	
Water-proof standard	Water-proof standard	Sealed type: JIS D 0203 S2, Dust cover type: JIS D 0203 R2		
Mass		Rubber bracket A type: 23 g .81 oz, Screw-mounting and direct coupling type: 19 g .67 oz		31 g 1.09 oz

Notes: *1. This value can change due to the switching frequency, environmental conditions, and desired reliability level, therefore it is recommended to check this with the actual load.

*2. The upper operation ambient temperature limit is the maximum temperature that can satisfy the coil temperature rise value. Please refer to "Usage ambient condition" in CAUTIONS FOR USE OF AUTOMOTIVE RELAYS.

2) 24 V DC type

Characteristics	Item		Specifications
			1 Form C type
Contact	Arrangement		1 Form C
	Contact resistance (Initial)		Typ 3mΩ (By voltage drop 6V DC 1A)
	Contact voltage drop		Max. 0.4 V (after electrical life test, by voltage drop 24 V DC 10 A)
	Contact material		Ag alloy (Cadmium free)
Rating	Nominal switching capacity (resistive load) (operating frequency: 2s ON, 2s OFF)		10 A 24V DC
	Max. carrying current		10 A continuous (at coil applied voltage 28 V DC, 80°C 176°F)
	Nominal operating power		1.8 W
	Min. switching capacity (resistive load)*1		1 A 24V DC
Electrical characteristics	Insulation resistance (Initial)		Min. 10 MΩ (at 500V DC)
	Breakdown voltage (Initial)	Between open contacts	500 Vrms for 1 min. (Detection current: 10mA)
		Between contacts and coil	500 Vrms for 1 min. (Detection current: 10mA)
	Operate time (at nominal voltage) (at 20°C 68°F)		Max. 10ms (excluding contact bounce time) (Initial)
	Release time (at nominal voltage) (at 20°C 68°F)		Max. 10ms (excluding contact bounce time) (Initial)
Mechanical characteristics	Shock resistance	Functional	Min. 100 m/s ² {10G} (Half-wave pulse of sine wave: 11ms; detection time: 10μs)
		Destructive	Min. 1,000 m/s ² {100G} (Half-wave pulse of sine wave: 6ms)
	Vibration resistance	Functional	33 Hz, Min. 44.1 m/s ² {4.5G} (Detection time: 10μs)
		Destructive	33 Hz, Min. 44.1 m/s ² {4.5G}, Time of vibration for each direction; X, Y direction: 2 hours, Z direction: 4 hours
Expected life	Electrical (at nominal switching capacity)		Min. 10 ⁵ (operating frequency: 2s ON, 2s OFF)
	Mechanical		Min. 5 × 10 ⁵ (at 120 cpm)
Conditions	Conditions for operation, transport and storage*2		Ambient temperature: -30°C to +80°C -22°F to +176°F, Humidity: 5% R.H. to 85% R.H. (Not freezing and condensing at low temperature)
	Max. operating speed		15 cpm (nominal switching capacity)
Water-proof standard	Water-proof standard		JIS D 0203 S2
Mass			31 g 1.09 oz

Notes: *1. This value can change due to the switching frequency, environmental conditions, and desired reliability level, therefore it is recommended to check this with the actual load.

*2. The upper operation ambient temperature limit is the maximum temperature that can satisfy the coil temperature rise value. Please refer to "Usage ambient condition" in CAUTIONS FOR USE OF AUTOMOTIVE RELAYS.

Electrical life

	Nominal coil voltage	Motor load (operating frequency ON: 2 s, OFF: 2 s)	Halogen lamp load (operating frequency ON: 1 s, OFF: 14 s)
1 Form A and 1 Form B type	12 V DC	Min. 10 ⁵ , 20 A 12 V DC	Min. 10 ⁵ , 20 A 12 V DC
1 Form C type	12 V DC	Min. 10 ⁵ , 20 A 12 V DC	Min. 10 ⁵ , 20 A 12 V DC
	24 V DC	Min. 10 ⁵ , 10 A 24 V DC	Min. 10 ⁵ , 6 A 24 V DC

REFERENCE DATA

1. Coil temperature rise

Samples: CA1aS-12V-N-5, 5pcs.

Measured portion: Inside the coil

Contact carrying current: 20A

Ambient temperature: Room temperature, 85°C

185°F

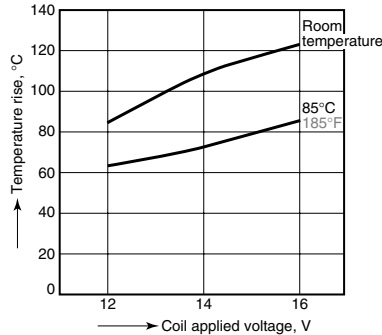

2. Max. switching capability (Resistive load, initial)

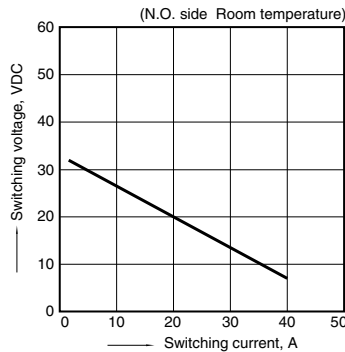

3. Ambient temperature and operating voltage range

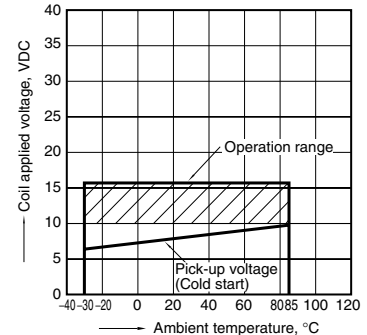

CA

4. Ambient temperature characteristics (Cold start)

Samples: CA1bS-12V-N-5

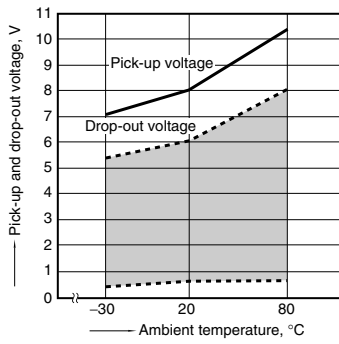

5. Distribution of pick-up and drop-out voltage

Quantity: 50pcs.

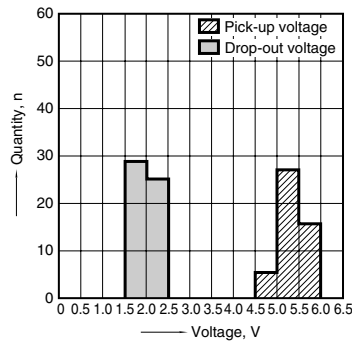

6. Operate and release time characteristics

Sample: CA1a-12V-N-5, 10pcs.

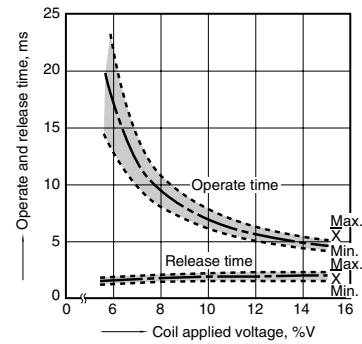

7-(1). Electrical life test (Motor load)

Sample: CA1a-12V-C, 3pcs.
 Load: Inrush current: 63A, steady current: 23A
 Blower fan motor actual load (motor free)
 Operating frequency: ON 2s, OFF 2s
 Ambient temperature: Room temperature

Load current waveform

Load: Inrush current: 63A, steady current: 23A,

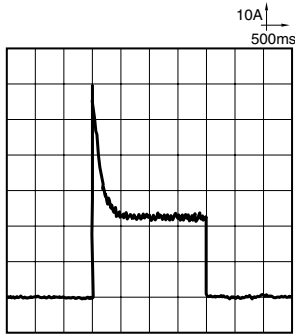

Change of pick-up and drop-out voltage

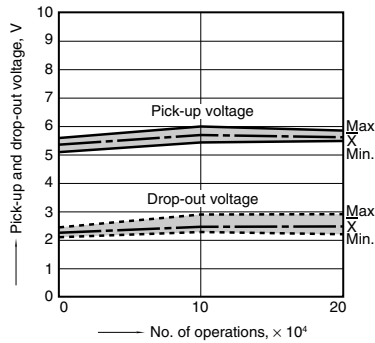

Change of contact resistance

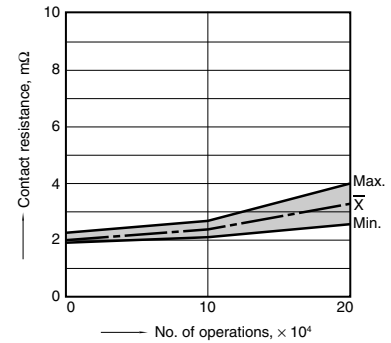

7-(2). Electrical life test (Lamp load)

Sample: CA1a-12V-C, 3pcs.
 Load: 60Wx4, Inrush current: 110A, steady current: 20A
 Halogen lamp actual load
 Operating frequency: ON 1s, OFF 14s
 Ambient temperature: Room temperature

Load current waveform

Load: Inrush current: 110A, steady current: 20A,

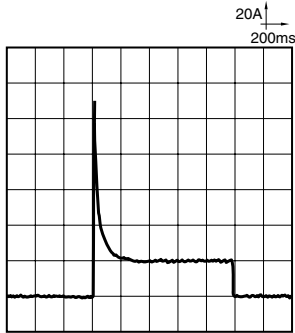

Change of pick-up and drop-out voltage

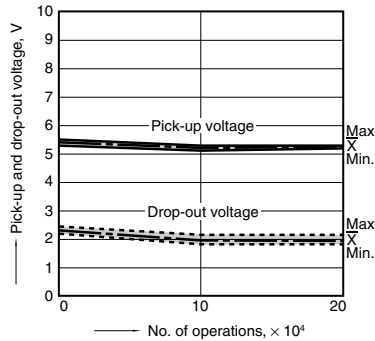

Change of contact resistance

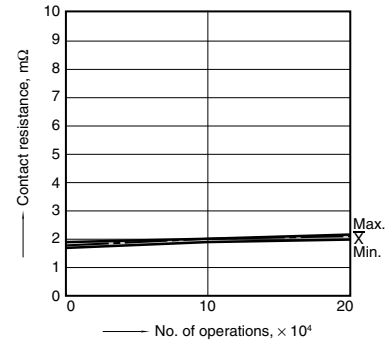

DIMENSIONS (mm inch)

The CAD data of the products with a **CAD Data** mark can be downloaded from: <http://industrial.panasonic.com/ac/e/>

**1. 1 Form A/1 Form B
Rubber bracket A type**

CAD Data



External dimensions

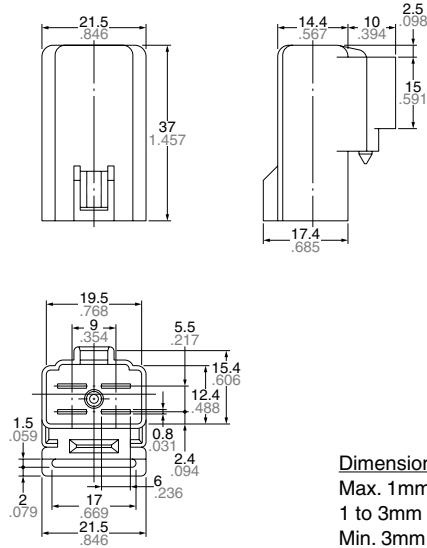

Schematic (Bottom View)

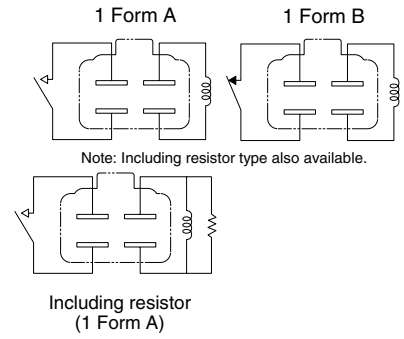

Dimension:	General tolerance
Max. 1mm .039 inch:	±0.1 ±.004
1 to 3mm .039 to .118 inch:	±0.2 ±.008
Min. 3mm .118 inch:	±0.3 ±.012

**2. 1 Form A/1 Form B
Screw-mounting type**

CAD Data



External dimensions

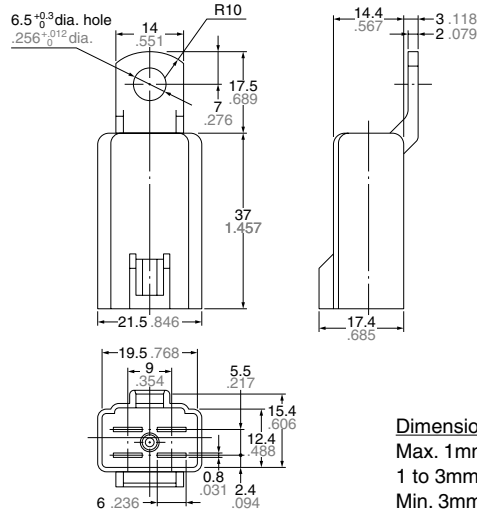

Schematic (Bottom View)

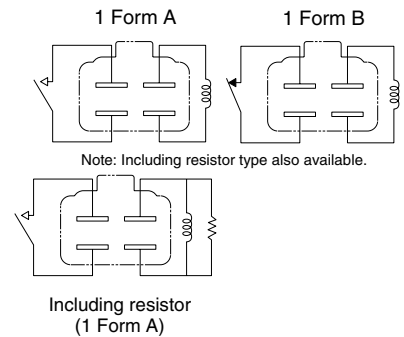

Dimension:	General tolerance
Max. 1mm .039 inch:	±0.1 ±.004
1 to 3mm .039 to .118 inch:	±0.2 ±.008
Min. 3mm .118 inch:	±0.3 ±.012

CA

3. 1 Form A/1 Form B Direct coupling type

CAD Data



External dimensions

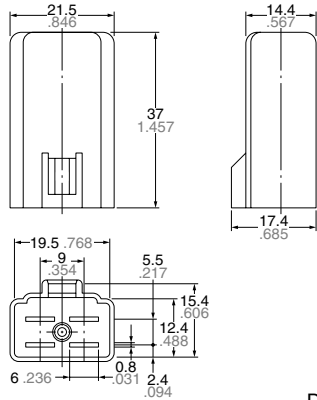

Schematic (Bottom View)

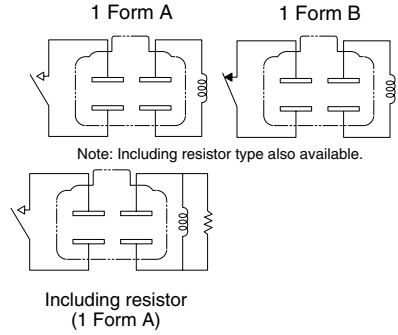

Dimension:

Max. 1mm .039 inch:

1 to 3mm .039 to .118 inch:

Min. 3mm .118 inch:

General tolerance

$\pm 0.1 \pm .004$

$\pm 0.2 \pm .008$

$\pm 0.3 \pm .012$

4. 1 Form C Screw-mounting type

CAD Data



External dimensions

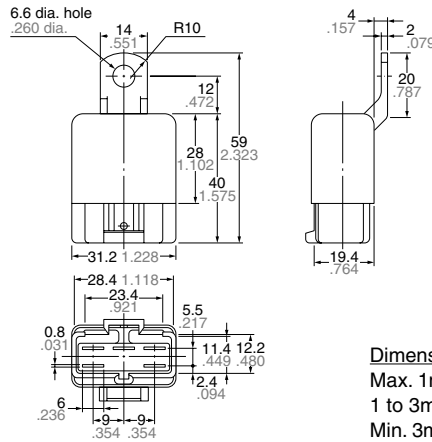

Schematic (Bottom View)

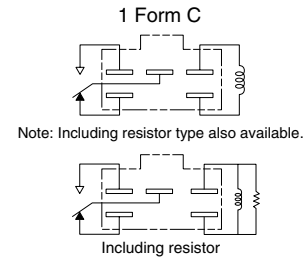

Dimension:

Max. 1mm .039 inch:

1 to 3mm .039 to .118 inch:

Min. 3mm .118 inch:

General tolerance

$\pm 0.1 \pm .004$

$\pm 0.2 \pm .008$

$\pm 0.3 \pm .012$

5. 1 Form C Direct coupling type

CAD Data



External dimensions

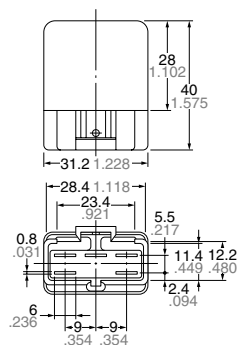

Schematic (Bottom View)

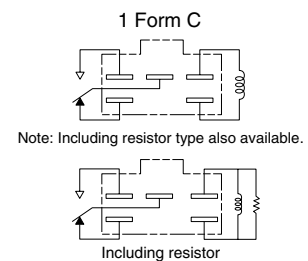

Dimension:

Max. 1mm .039 inch:

1 to 3mm .039 to .118 inch:

Min. 3mm .118 inch:

General tolerance

$\pm 0.1 \pm .004$

$\pm 0.2 \pm .008$

$\pm 0.3 \pm .012$

For Cautions for Use, see Relay Technical Information.