

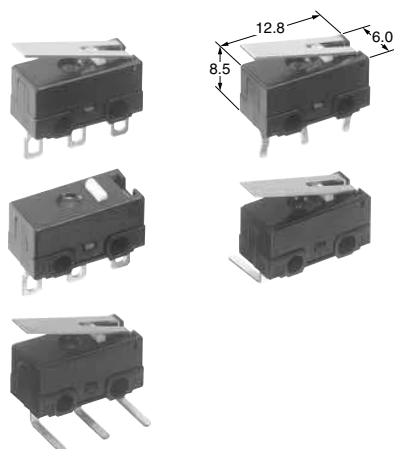

Panasonic
ideas for life

**ULTRA-MINIATURE
SWITCHES
WITH HIGH PRECISION**

**AH1 (FJ)
SWITCHES**



FEATURES

- Integrally molded terminal block—prevents soldering flux from entering into housing
- Compact size—minimizes size of equipment
- Flat terminal shape—makes soldering easy
- Low-level circuit type available
- Self-standing PC board terminal type available

TYPICAL APPLICATIONS

- Computer mouse
- Charger unit for mobile phone
- Detection of key position for automobiles

RoHS compliant

ORDERING INFORMATION

Ex. AH 1 4 8 0 61 9

Product Name	Terminal	Operating force by pin plunger (max.)	Actuator	Contact	Agency standard
FJ	4: 2.0 mm Self-standing PC board terminal with stand off 5: Straight PC board terminal with stand off 6: 2.0 mm solder terminal with stand off 7: 2.0 mm PC board right angle terminal 8: 2.0 mm PC board left angle terminal	6: 1.47 N with stand off 8: 0.74 N with stand off	0: Pin plunger 2: Hinge lever 4: Simulated roller lever	Nil: AgNi alloy 61: AgNi alloy + Gold-clad	9: UL/CSA

Remark: 2.0 mm PC board terminal straight type is available. For details, please consult us.

PRODUCT TYPES

The color of:

Type	Color		
	Body	Cap	Plunger
Standard	Black	Black	White
Low-level circuit	Black	Black	Red

1. Self-standing PC board terminal

Actuators	Operating force, Max.	Standard (AgNi alloy contact)	Low-level circuit (AgNi alloy + Gold-clad contact)
		SPDT	SPDT
Pin plunger	0.74 N	AH14809	AH1480619
	1.47 N	AH14609	AH1460619
Hinge lever	0.25 N	AH14829	AH1482619
	0.49 N	AH14629	AH1462619
Simulated roller lever	0.26 N	AH14849	AH1484619
	0.54 N	AH14649	AH1464619

AH1

2. Solder terminal

Actuators	Operating force, Max.	Standard (AgNi alloy contact)	Low-level circuit (AgNi alloy + Gold-clad contact)
		SPDT	SPDT
Pin plunger	0.74 N	AH16809	AH1680619
	1.47 N	AH16609	AH1660619
Hinge lever	0.25 N	AH16829	AH1682619
	0.49 N	AH16629	AH1662619
Simulated roller lever	0.26 N	AH16849	AH1684619
	0.54 N	AH16649	AH1664619

3. Straight PC board terminal

Actuators	Operating force, Max.	Standard (AgNi alloy contact)	Low-level circuit (AgNi alloy + Gold-clad contact)
		SPDT	SPDT
Pin plunger	0.74 N	AH15809	AH1580619
Pin plunger	1.47 N	AH15609	AH1560619
Hinge lever	0.25 N	AH15829	AH1582619
Hinge lever	0.49 N	AH15629	AH1562619
Simulated roller lever	0.26 N	AH15849	AH1584619
Simulated roller lever	0.54 N	AH15649	AH1564619

4. PC board terminal right angle

Actuators	Operating force, Max.	Standard (AgNi alloy contact)	Low-level circuit (AgNi alloy + Gold-clad contact)
		SPDT	SPDT
Pin plunger	0.74 N	AH17809	AH1780619
Pin plunger	1.47 N	AH17609	AH1760619
Hinge lever	0.25 N	AH17829	AH1782619
Hinge lever	0.49 N	AH17629	AH1762619
Simulated roller lever	0.26 N	AH17849	AH1784619
Simulated roller lever	0.54 N	AH17649	AH1764619

5. PC board terminal left angle

Actuators	Operating force, Max.	Standard (AgNi alloy contact)	Low-level circuit (AgNi alloy + Gold-clad contact)
		SPDT	SPDT
Pin plunger	0.74 N	AH18809	AH1880619
	1.47 N	AH18609	AH1860619
Hinge lever	0.25 N	AH18829	AH1882619
	0.49 N	AH18629	AH1862619
Simulated roller lever	0.26 N	AH18849	AH1884619
	0.54 N	AH18649	AH1864619

Remarks: 1. The appearance of right and left angle types are as below.

Right angle



Left angle



2. Standard packing: 50 pcs./tube.

3. Please consult us for the delivery schedule of PC board terminal SPST-NO type.

APPLICABLE CURRENT RANGE

Contact	Applicable current range				Max. operating force for operation (at pin plunger)	
	1 mA	0.1 A	1 A	3 A	0.74 N	1.47 N
Standard type (AgNi alloy)			●		●	
			●			●
Low level circuit type (AgNi alloy + Gold-clad)	●				●	
	●					●

SPECIFICATIONS

1. Contact rating (resistive load)

		Standard rating	Minimum rating
Standard type	O.F. 0.74N	1A 125V AC, 1A 30V DC	—
	O.F. 1.47N	3A 125V AC, 2A 30V DC	—
Low-level circuit type		0.1A 125V AC, 0.1A 30V DC	5mA 6V DC, 2mA 12V DC, 1mA 24V DC

2. Characteristics

Contact arrangement	Standard type	Low-level circuit type
Expected life (Min. operations) Electrical (at rated load, 20 cpm) (O.T.: Max.)	3×10^4	10^5
Expected life (Min. operations) Mechanical (at 60 cpm) (O.T.: Specified value)		O.F. 0.74 N: 10^6 O.F. 1.47 N: 5×10^5
Dielectric strength (initial) Between terminals Between terminals and other exposed parts Between terminals and ground		600 Vrms for 1 min. 1,500 Vrms for 1 min. 1,500 Vrms for 1 min.
Insulation resistance (Min. at 500V DC)		100 M Ω
Initial contact resistance	Max. 30 m Ω (by voltage drop, 1A 6 to 8V DC)	Max. 100 m Ω (by voltage drop, 0.1A 6 to 8V DC)
Allowable operating speed (No load)	1 to 500 mm/sec.	
Max. operating cycle rate (No load)	120 cpm	
Ambient temperature	-25 to +85°C (Not freezing below 0°C)	
Shock resistance (Pin plunger type)	Min. 294 m/s ² (Contact opening: Max. 1 msec.)	
Vibration resistance (Pin plunger type)	10 to 55 Hz at single amplitude of 0.75mm (Contact opening: Max. 1 msec.)	

3. Operating characteristics

1) Pin plunger

3th digit of Part No.	Operating force, Max.	Release force, Min.	Pretravel, Max. mm	Movement differential, Max. mm	Overtravel, Min. mm	Operating position mm
6	0.47 N	0.20 N	0.5	0.12	0.25	7 \pm 0.3 (Distance from stand off) 5.5 \pm 0.2 (Distance from mounting hole)
8	0.74 N	0.098 N				7 \pm 0.3 (Distance from stand off) 5.5 \pm 0.2 (Distance from mounting hole)

2) Hinge lever

3th digit of Part No.	Operating force, Max.	Release force, Min.	Pretravel, Max. mm	Movement differential, Max. mm	Overtravel, Min. mm	Operating position mm
6	0.49 N	0.049 N	2.1	0.5	0.55	8.3 \pm 1.2 (Distance from stand off) 6.8 \pm 1.0 (Distance from mounting hole)
8	0.25 N	0.025 N				8.3 \pm 1.2 (Distance from stand off) 6.8 \pm 1.0 (Distance from mounting hole)

3) Simulated roller lever

3th digit of Part No.	Operating force, Max.	Release force, Min.	Pretravel, Max. mm	Movement differential, Max. mm	Overtravel, Min. mm	Operating position mm
6	0.54 N	0.039 N	2.1	0.5	0.5	11.0 \pm 1.2 (Distance from stand off) 9.5 \pm 1.0 (Distance from mounting hole)
8	0.26 N	0.020 N				11.0 \pm 1.2 (Distance from stand off) 9.5 \pm 1.0 (Distance from mounting hole)

AH1

DATA

Gold-clad type

Range of low-level current voltage

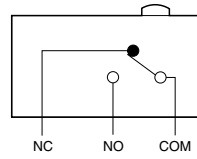
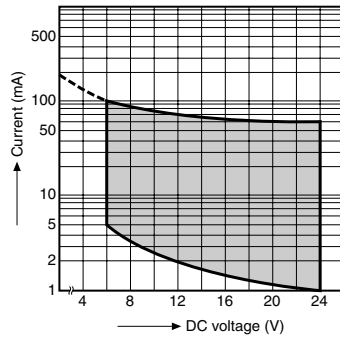

CONTACT ARRANGEMENT

DIMENSIONS

The CAD data of the products with a **CAD Data** mark can be downloaded from: <http://industrial.panasonic.com/ac/e>

1. Self-standing PC board terminal (Standard type)

Pin plunger

mm

CAD Data

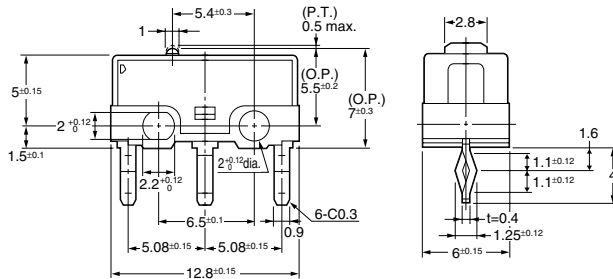

PC board pattern

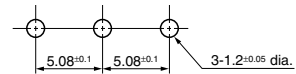

Pretravel, Max. mm	0.5	
Movement differential, Max. mm	0.12	
Overtravel, Min. mm	0.25	
Operating position	Distance from mounting hole, mm	5.5±0.2
	Distance from standoff, mm	7±0.3

Hinge lever

CAD Data

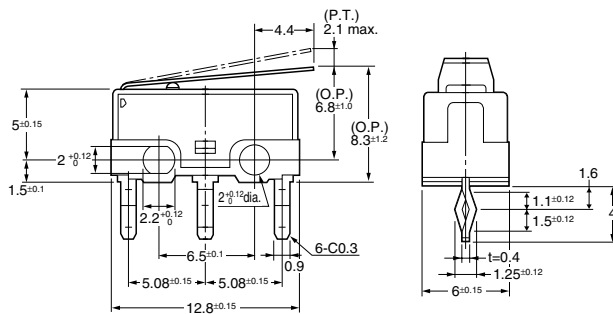

PC board pattern

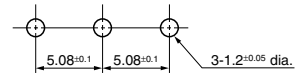

Pretravel, Max. mm	2.1	
Movement differential, Max. mm	0.5	
Overtravel, Min. mm	0.5	
Operating position	Distance from mounting hole, mm	6.8±1.0
	Distance from standoff, mm	8.3±1.2

Simulated roller lever

CAD Data

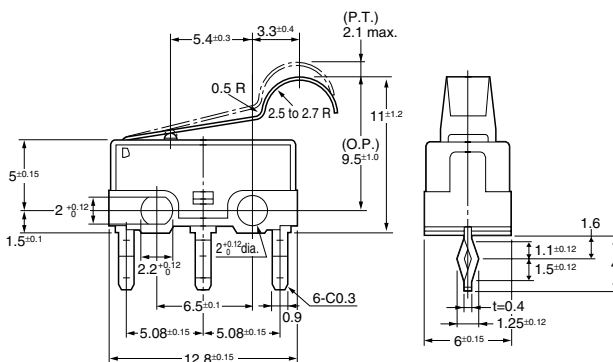

PC board pattern

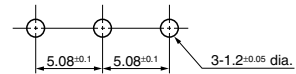

Pretravel, Max. mm	2.1	
Movement differential, Max. mm	0.5	
Overtravel, Min. mm	0.5	
Operating position	Distance from mounting hole, mm	9.5±1.0
	Distance from standoff, mm	11.0±1.2

2. Solder terminal

Pin plunger

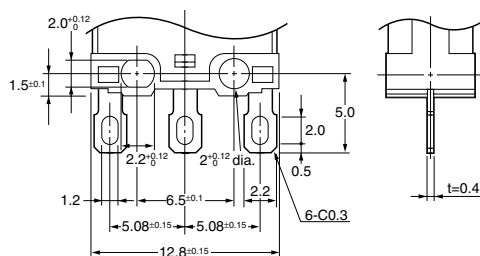
CAD Data

Remark: As for other actuator types, dimensions are the same as those of corresponding standard PC board terminal type.

3. PC board terminal (Right/Left angle type)

Pin plunger

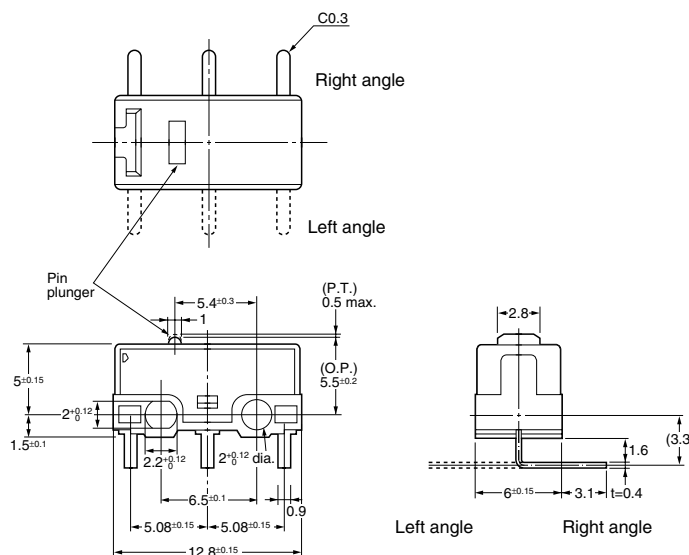
CAD Data

Remark: As for other actuator types, dimensions are the same as those of corresponding standard PC board terminal type.

NOTES**1. Fixing**

1) Use 2mm mounting screws to attach switches with Max. 0.098 N·m torque.

Use of screw washers or adhesive lock is recommended.

2) When the operation object is in the free position, force should not be applied directly to the actuator or to the pin plunger. Also force should be applied to the pin plunger from vertical direction to the switch.

3) In setting the movement after operation, the over-travel should be set from 70% to 100%. Setting the movement less than 70% may cause degrading of the electrical mechanical performance.

2. When specifying AH1 switches,

allow ±20% to the listed operating and release forces.

3. Soldering operation

Manual soldering should be accomplished within 3 seconds with max. 350°C iron.

Terminal portions must not be moved in min. 1 minute after soldering.

Also no tensile strength of lead wires should be applied to terminals.

4. When switching low-level circuits,

AH1 low-level circuit type is recommended.