

Knob Potentiometer



FEATURES

- 1 W at 40 °C
- Test according to CECC 41300
- **P16** - version for professional and industrial applications
- **PA16** - version for professional audio applications
- Compact (integrated)
- Minimum clearance required
- Safety in use due to good insulation: $> 10^4 \text{ M}\Omega$ 500 V_{DC}
- High dielectric strength: 2500 V_{RMS}
- Fully sealed and panel sealed
- Metallic or plastic knob options
- Cermet or conductive plastic



The P16 is a revolutionary concept in panel mounted potentiometers. This unique design consists of a knob driving and incorporating a cermet potentiometer. Only the mounting hardware and terminals are situated on the back side of the panel reducing to a minimum the required clearance.

DIMENSIONS in millimeters ($\pm 0.5 \text{ mm}$)

P16 - PA16

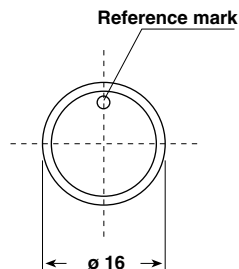
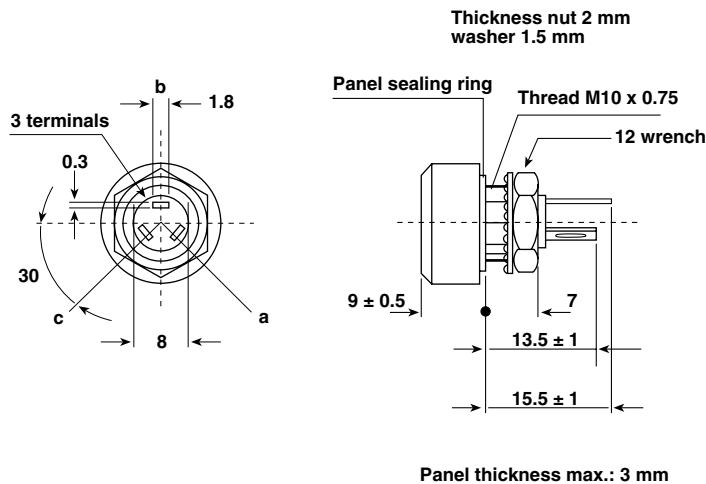

PANEL CUTOUT

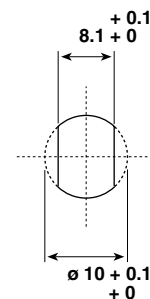

ELECTRICAL SPECIFICATIONS			
	P16	PA16	
Resistive Element	cermet	conductive plastic	
Electrical Travel	270° ± 10°	270° ± 10°	
Power Rating Chart			
Circuit Diagram			
Resistance Laws			
Resistance Range	linear law logarithmic laws	22 Ω to 10 MΩ 100 Ω to 2.2 MΩ	1 kΩ to 1 MΩ 470 Ω to 500 kΩ
Standard Series E3		1 - 2.2 - 4.7 and on request 1 - 2 - 5	1 - 2.2 - 4.7
Tolerance	standard on request	± 20 % ± 10 %	± 20 % ± 10 % (1 kΩ to 100 kΩ)
Power Rating	linear logarithmic	1 W at + 40 °C 0.5 W at + 40 °C	0.5 W at + 40 °C 0.25 W at + 40 °C
Temperature Coefficient (Typical)		± 150 ppm/°C	± 1000 ppm/°C
Dielectric Strength (RMS)		2500 V	2500 V
Limiting Element Voltage (Linear Law)		350 V	350 V
Insulation Resistance (500 VDC)		≥ 10 ⁴ MΩ	≥ 10 ⁴ MΩ
Contact Resistance Variation		3 % Rn or 3 Ω	2 % Rn or 3 Ω
End Resistance (Typical)		1 Ω	1 Ω
Insulation Resistance (500 VDC)		10 ⁶ MΩ	10 ⁶ MΩ



MECHANICAL SPECIFICATIONS	
Mechanical Travel	300° ± 5°
Operating Torque	2 Ncm typical
End Stop Torque	25 Ncm maximum
Max. Tightening Torque of Mounting Nut	250 Ncm maximum
Unit Weight	4.5 g typical

ENVIRONMENTAL SPECIFICATIONS		
	Metallic Knob	Plastic Knob
Temperature Range	- 40 °C to 125 °C	- 40 °C to 85 °C
Climatic Category	40/100/56	40/85/56
Sealing	sealed container and panel sealed	
Protection Grades	IP67	

MARKING
<ul style="list-style-type: none"> VISHAY trademark Ohmic value Tolerance (in %) Resistance law Manufacturing date

PACKAGING
<ul style="list-style-type: none"> Carton box of 20 pieces

CONTROL KNOB

Black metallic knob (NM).
 Black plastic knob (NP).
 For white and blue color see ordering information.
 Other dimensions, shapes, colors of control knobs are manufactured on request - please consult VISHAY.
 Other reference marks (shapes, colours) and legends can be printed on plastic knob on request - please consult VISHAY.

P16 STANDARD RESISTANCE ELEMENT DATA							
STANDARD RESISTANCE VALUES	LINEAR LAW			LOG LAW			TYP. TCR -40 °C + 85 °C
	MAX. POWER AT 40 °C	MAX. VOLTAGE	MAX. CUR. THROUGH WIPER	MAX. POWER AT 40 °C	MAX. VOLTAGE	MAX. CUR. THROUGH WIPER	
Ω	W	V	mA	W	V	mA	10 ⁻⁶ /°C
22	1	4.69	213				± 150
47		6.85	146				
100		10	100	0.5	7.1	71	
220		14.8	67.4		10.5	48	
470		21.7	46.1		15.3	32.6	
1K		31.6	31.6		22.4	22.4	
2.2K		46.9	21.3		33.2	15.1	
4.7K		68.5	14.6		48.5	10.3	
10K		100	10		70.7	7.07	
22K		148	6.74		105	4.77	
47K		217	4.61		153	3.26	
100K	1	316	3.16		224	2.24	
220K	0.56	350	1.59	0.5	332	1.51	
470K	0.26	350	0.75	0.26	350	0.74	
1M	0.12	350	0.35	0.12	350	0.35	
2.2M	0.05	350	0.16	0.056	350	0.16	
4.7M	0.02	350	0.07				
10M	0.01	350	0.012				

PA16 STANDARD RESISTANCE ELEMENT DATA							
STANDARD RESISTANCE VALUES	LINEAR LAW			LOG LAW			TYP. TCR -55 °C + 125 °C
	MAX. POWER AT 40 °C	MAX. VOLTAGE	MAX. CUR. THROUGH WIPER	MAX. POWER AT 70 °C	MAX. VOLTAGE	MAX. CUR. THROUGH WIPER	
Ω	W	V	mA	W	V	mA	ppm/°C
470				0.25	10.8	23.1	± 1000
1K	0.5	22.4	22.4		15.8	16	
2.2K		33.2	15.1		23.5	11	
4.7K		48.5	10.3		34.3	7	
10K		79.7	7.07		50.0	5.0	
22K		105	4.77		74	3.4	
47K		153	3.26		108	2.3	
100K		224	2.24		158	1.6	
220K	0.5	332	1.51		235	1.1	
470K	0.26	350	0.74	0.25	343	0.7	
1M	0.12	350	0.35				



PERFORMANCE			
TESTS	CONDITIONS	TYPICAL VALUES AND DRIFTS	
		$\Delta R_T/R_T$ (%)	$\Delta R_{1-2}/R_{1-2}$ (%)
Load Life	1000 h at Pn 90°/30' cycle at + 40 °C	± 5 % Insulation resistance: > 10 ⁴ MΩ Contact res. variation: < 2 % Rn	-
Long Term Damp Heat	56 days 40 °C, 93 % HR	± 2 % Insulation resistance: > 10 ⁴ MΩ	± 1 %
Shock	50 g at 11 ms 3 successive shocks in 3 axes	± 0.2 %	± 0.5 %
Vibration	10 - 55 Hz 0.75 mm or 10 g during 6 h	± 0.2 %	$\Delta V_{1-2}/\Delta V_{1-3} \leq \pm 0.5 \%$
Rotational Life	50 000 cycles	± 5 % Contact res. variation: < 2 % Rn	-

SAP ORDERING INFORMATION																		
P	1	6	N	P	2	2	3	M	A	B	1	5						
MODEL	STYLE			OHMIC VALUE			TOLERANCE	TAPER			PACKAGING CODE	SPECIAL NUMBER						
P16 = Cermet PA16 = Conductive plastic	NM : Metallic black NP : Plastic black WM : Metallic white WP : Plastic white BP : Plastic blue			223 = 22 kΩ for ohmic value range see ELECTRICAL SPECIFICATION			M = ± 20 % on request K = ± 10 %	A : Linear L : Clockwise logarithmic F : Inverse clockwise logarithmic			B15 = Box of 20 pieces	(if applicable) given by VISHAY for custom design						

PART NUMBER DESCRIPTION (for information only)								
P16	NP	22 kΩ	20 %	A		BO20		e3
MODEL	STYLE	VALUE	TOLERANCE	TAPER	SPECIAL	PACKAGING	SPECIAL	LEAD (Pb)-FREE



Disclaimer

All product specifications and data are subject to change without notice.

Vishay Intertechnology, Inc., its affiliates, agents, and employees, and all persons acting on its or their behalf (collectively, "Vishay"), disclaim any and all liability for any errors, inaccuracies or incompleteness contained herein or in any other disclosure relating to any product.

Vishay disclaims any and all liability arising out of the use or application of any product described herein or of any information provided herein to the maximum extent permitted by law. The product specifications do not expand or otherwise modify Vishay's terms and conditions of purchase, including but not limited to the warranty expressed therein, which apply to these products.

No license, express or implied, by estoppel or otherwise, to any intellectual property rights is granted by this document or by any conduct of Vishay.

The products shown herein are not designed for use in medical, life-saving, or life-sustaining applications unless otherwise expressly indicated. Customers using or selling Vishay products not expressly indicated for use in such applications do so entirely at their own risk and agree to fully indemnify Vishay for any damages arising or resulting from such use or sale. Please contact authorized Vishay personnel to obtain written terms and conditions regarding products designed for such applications.

Product names and markings noted herein may be trademarks of their respective owners.