

26.0-40.0 GHz GaAs MMIC Power Amplifier

Features

- X 26.0–40.0 GHz Frequency Range
- X 12 dB Typical Small Signal Gain
- X Excellent Input/Output Return Loss
- X +36.0 dBm Typical Third Order Intercept Point (IP3)
- X Operates at +5.5 VDC
- X 3.00 mm X 2.50 mm Die Size
- X 100% On-Wafer RF, DC and Output Power Testing
- X 100% Visual Inspection to MIL-STD-883 Method 2010

General Description

Mimix Broadband's two stage 26.0–40.0 GHz GaAs MMIC power amplifier is optimized for linear operation with a typical third order intercept point of +36.0 dBm. The device also has a typical small signal gain of 12.0 dB and includes Lange couplers to achieve good input/output return loss. This MMIC uses Mimix Broadband's 0.15 μm GaAs PHEMT device model technology, and is based upon electron beam lithography to ensure high repeatability and uniformity. The chip has surface passivation to protect and provide a rugged part with backside via holes and gold metallization to allow either a conductive epoxy or eutectic solder die attach process. This device is well suited for Millimeter-wave Point-to-Point Radio, LMDS, SATCOM and VSAT applications.

Chip Device Layout

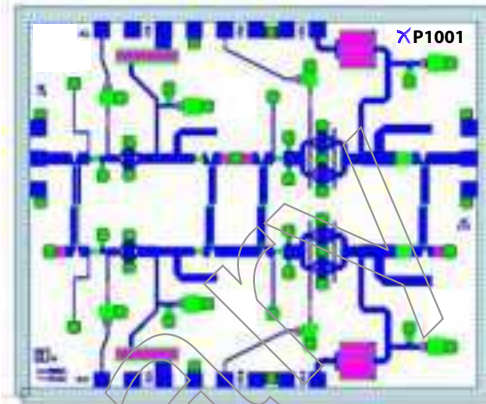

Absolute Maximum Ratings

Supply Voltage (Vd)	+5.6 Vdc
Supply Current (Id)	650 mA
Gate Bias Voltage (Vg)	+0.3 Vdc
Input Power (Pin)	+10.0 dBm
Storage Temperature (Tstg)	-65 to +165 °C
Operating Temperature (Ta)	-55 to +75 °C
Channel Temperature (Tch)	125 °C
Thermal Resistance (θ_{jc})	35 °C/W

Electrical Characteristics (Ambient Temperature T=25°C)

Parameter	Units	Min.	Typ.	Max.
Frequency Range (f)	GHz	26.0	-	40.0
Input Return Loss (S11)	dB	15.0	18.0	-
Output Return Loss (S22)	dB	15.0	18.0	-
Small Signal Gain (S21)	dB	10.0	12.0	-
Gain Flatness (ΔS_{21})	dB	-	+/-1.0	-
Reverse Isolation (S12)	dB	-	40.0	-
Output Power for 1 dB Compression (P1 dB)	dBm	-	+24.0	-
Output Third Order Intercept (IP3)	dBm	-	+36.0	-
Drain Bias Voltage (Vd1,2,3,4)	Vdc	-	5.5	5.6
Gate Bias Voltage (Vg1,2,3,4)	Vdc	-1.0	-0.3	+0.3
Supply Current (Id) (Vd=5.5V, Vg=-0.3V Typical)	mA	-	430	650

26.0-40.0 GHz GaAs MMIC Power Amplifier

June 2001 - Rev 6/06/01

Mechanical Drawing

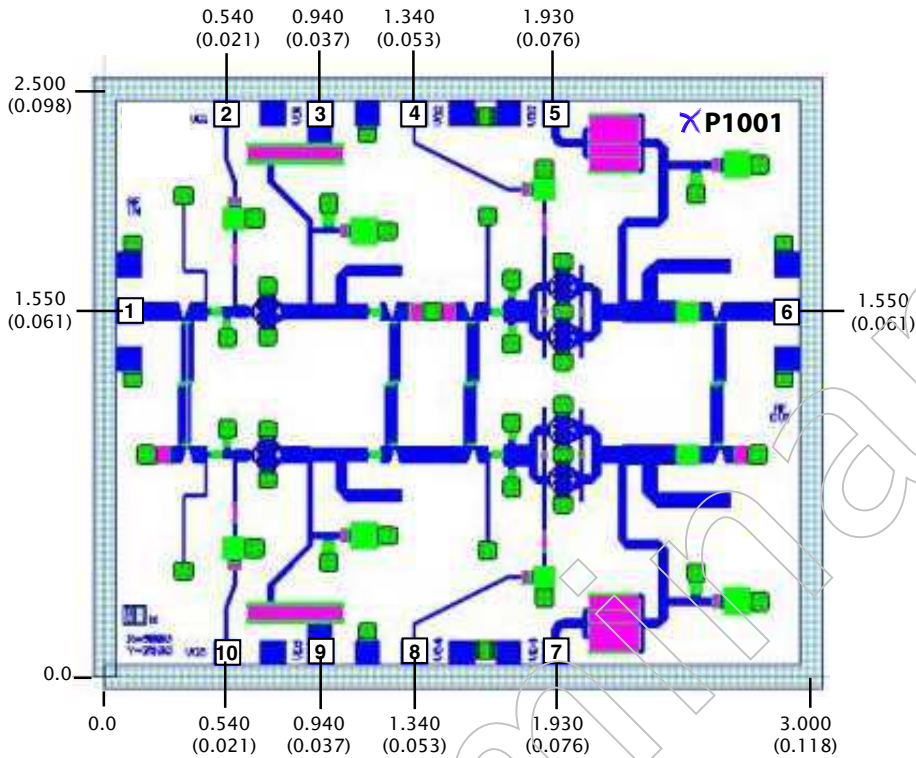

Units: millimeters (inches) Bond pad dimensions are shown to center of bond pad.
 Thickness: 0.100 (0.004) (for reference only), Backside is ground, Bond Pad/Backside Metallization: Gold
 All Bond Pads are 0.100 x 0.100 (0.004 x 0.004).

Bond Pad #1 (RF In)	Bond Pad #3 (Vd1)	Bond Pad #5 (Vd2)	Bond Pad #7 (Vd4)	Bond Pad #9 (Vd3)
Bond Pad #2 (Vg1)	Bond Pad #4 (Vg2)	Bond Pad #6 (RF Out)	Bond Pad #8 (Vg4)	Bond Pad #10 (Vg3)

Bias Arrangement

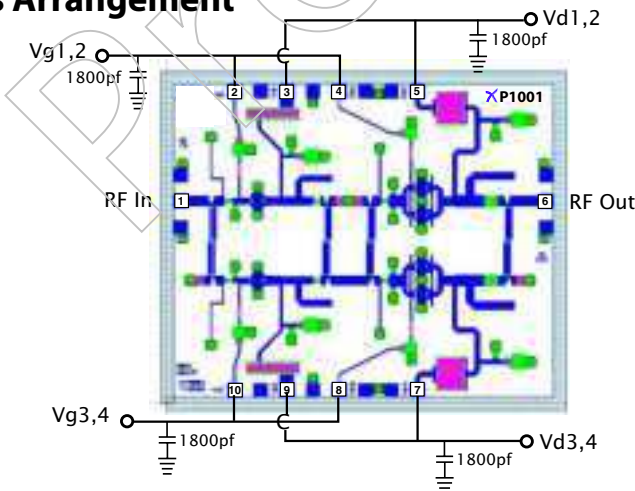

Mimix Broadband, 520 W. NASA Road One, Webster, Texas 77598
 Tel: 281.526.0536 Fax: 281.526.0541 mimixbroadband.com

Page 2 of 3

Characteristic Data and Specifications are subject to change without notice. ©2001 Mimix Broadband.
 Export of this item may require appropriate export licensing from the U.S. Government. In purchasing these parts, U.S. Domestic customers accept their obligation to be compliant with U.S. Export Laws.

26.0-40.0 GHz GaAs MMIC Power Amplifier

June 2001 – Rev 6/06/01

Handling and Assembly Information

CAUTION! – Mimix Broadband MMIC Products contain *gallium arsenide (GaAs)* which can be hazardous to the human body and the environment. For safety, observe the following procedures:

- Do not ingest.
- Do not alter the form of this product into a gas, powder, or liquid through burning, crushing, or chemical processing as these by products are dangerous to the human body if inhaled, ingested, or swallowed.
- Observe government laws and company regulations when discarding this product. This product must be discarded in accordance with methods specified by applicable hazardous waste procedures.

ESD – Gallium Arsenide (GaAs) devices are susceptible to electrostatic and mechanical damage. Die are supplied in antistatic containers, which should be opened in cleanroom conditions at an appropriately grounded anti-static workstation. Devices need careful handling using correctly designed collets, vacuum pickups or, with care, sharp tweezers.

Die Attachment – GaAs Products from Mimix Broadband are 0.100 mm (0.004) thick and have vias through to the backside to enable grounding to the circuit. Microstrip substrates should be brought as close to the die as possible. The mounting surface should be clean and flat. If using conductive epoxy, recommended epoxies are Ablestick 84-1LMI or 84-1LMI cured in a nitrogen atmosphere per manufacturer s cure schedule. Apply epoxy sparingly to avoid getting any on to the top surface of the die. An epoxy fillet should be visible around the total die periphery. If eutectic mounting is preferred, then a fluxless gold-tin (AuSn) preform, approximately 0.001² thick, placed between the die and the attachment surface should be used. A die bonder that utilizes a heated collet and provides scrubbing action to ensure total wetting to prevent void formation in a nitrogen atmosphere is recommended. The gold-tin eutectic (80% Au 20% Sn) has a melting point of approximately 280°C (Note: Gold Germanium should be avoided). The work station temperature should be 310°C ±10°C. Exposure to these extreme temperatures should be kept to minimum. The collet should be heated, and the die pre-heated to avoid excessive thermal shock. Avoidance of air bridges and force impact are critical during placement.

Wire Bonding – Windows in the surface passivation above the bond pads are provided to allow wire bonding to the die s gold bond pads. The recommended wire bonding procedure uses 0.076 mm x 0.013 mm (0.003 x 0.0005) 99.99% pure gold ribbon with 0.5-2% elongation to minimize RF port bond inductance. Gold 0.025 mm (0.001) diameter wedge or ball bonds are acceptable for DC Bias connections. Aluminum wire should be avoided. Thermo-compression bonding is recommended though thermosonic bonding may be used providing the ultrasonic content of the bond is minimized. Bond force, time and ultrasonics are all critical parameters. Bonds should be made from the bond pads on the die to the package or substrate. All bonds should be as short as possible.