

RS2030

Lowest Cost Green-Power Off-Line PWM Controller

General Description

The RS2030 is a high performance green-power offline power supply PWM controller. It features a scalable driver for driving external NPN (13003) or MOSFET transistors for line voltage switching. This proprietary architecture enables many advanced features to be integrated into a small package (TO-92), resulting in lowest total cost solution.

The RS2030 automatically enters the CRM (Cycle Reset Mode) under light-load/zero-load conditions.

Consuming only 0.15W in standby, the RS2030 features over-current, short circuits and under-voltage protection mechanisms. This can minimize standby power consumption and achieve green-power functions. With a very low start-up current, the RS2030 could use a large value start-up resistor

Features

- Low Start-up Current
- 0.15W Standby Power
- Emitter Drive Allows Safe NPN Fly-back Use
- Cycle-by-cycle current limiting
- Built-in Synchronized Slope Compensation
- Current Mode Operation
- Over-Current Protection (OCP) ※Selectable 400mA to 800mA Current Limit
- Short Circuits Protection (SCP)
- Under-voltage Protection with Auto-restart
- Proprietary Scalable Output Driver
- HBM ESD Voltage > 5000V
- 67KHz or 100KHz Fixed Switching Frequency
- Built-in high Voltage MOSFET (>30V)
- Available in an TO-92 Package
- RoHS Compliant and 100% Lead (Pb)-Free

Applications

- Battery Charger Adapter
- Standby Power Supplies
- Universal OFF-Line Power Supplies

Application Circuits

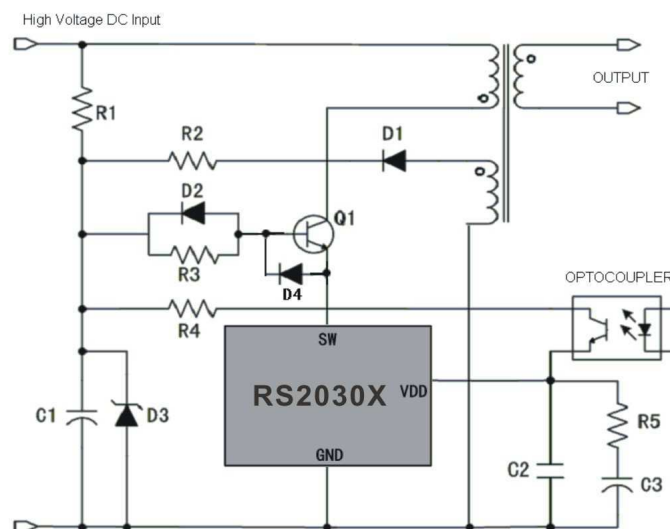

This integrated circuit can be damaged by ESD. Orister Corporation recommends that all integrated circuits be handled with appropriate precautions. Failure to observe proper handling and installation procedures can cause damage.

ESD damage can range from subtle performance degradation to complete device failure. Precision integrated circuits may be more susceptible to damage because very small parametric changes could cause the device not to meet its published specifications.

Pin Assignments

TO-92

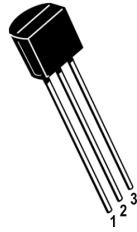

PACKAGE	PIN	SYMBOL	DESCRIPTION
TO-92	1	V _{DD}	Power Supply Pin. Connect to optocoupler's emitter. Internally limited to 5.6V max. Bypass to GND with a proper compensation network.
	2	GND	Ground Pin.
	3	SW	Output Pin. Connect to emitter of the high voltage NPN or MOSFET.

Ordering Information

PART NUMBER	FREQUENCY	PEAK CURRENT	FREQUENCY JITTER	PACKAGE
RS2030A	67KHz	400mA	Y	TO-92
RS2030B	100KHz	400mA	Y	TO-92
RS2030C	67KHz	400mA	N	TO-92
RS2030D	100KHz	400mA	N	TO-92
RS2030E	67KHz	800mA	Y	TO-92
RS2030F	100KHz	800mA	Y	TO-92
RS2030G	67KHz	800mA	N	TO-92
RS2030H	100KHz	800mA	N	TO-92

Block Diagram

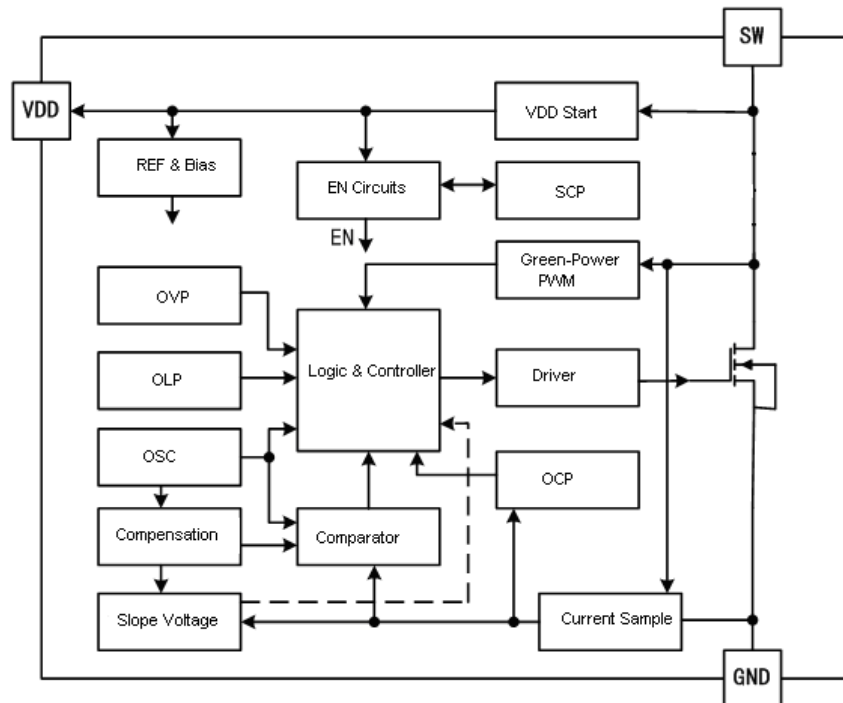

Absolute Maximum Ratings

PARAMETER	VALUE	UNIT
V _{DD} Pin Voltage	-0.3 to 6	V
V _{DD} Current	20	mA
SW Pin Voltage	-0.3 to 30	V
SW Current	Internally limited	A
Maximum Power Dissipation (TO-92)	0.6	W
Operating Junction Temperature	-40 to +150	°C
Storage Temperature	-55 to +150	°C
Lead Temperature (Soldering, 10 sec)	300	°C
ESD Voltage (HBM)	5500	V

Electrical Characteristics (V_{DD}=4.5V, T_A=25°C, unless otherwise specified)

Symbol	PARAMETER	TEST CONDITIONS	MIN.	TYP.	MAX.	UNIT
V _{START}	V _{DD} Start Voltage	Rising edge	5.20	5.40	5.60	V
V _{SWST}	SW Start Voltage	-	8.00	8.60	9.20	V
V _{UV}	V _{DD} Under-voltage Threshold	Falling edge	3.40	3.60	3.80	V
V _{VDD (Max)}	V _{DD} Clamp Voltage	I _{VDD} =10mA	5.40	5.60	5.80	V
I _{DDST}	Startup Supply Current	V _{DD} =4V before V _{UV}	-	0.20	0.40	mA
I _{DD}	V _{DD} Supply Current	-	-	1.50	2.00	mA
f _{SW}	Switching Frequency	RS2030A	62	67	72	KHz
		RS2030B	90	100	110	
D _{MAX}	Maximum Duty Cycle	V _{DD} =5.0V	62.7	66.7	71.7	/
D _{MIN}	Minimum Duty Cycle	V _{DD} =5.0V	-	3.5	-	/
I _{LIM}	Effective Current Limit	V _{DD} =V _{UV} +0.1V	380	400	420	mA
			760	800	840	
G _{GAIN}	V _{DD} to SW Current Coefficient	-	-	0.29	-	A/V
R _{VDD}	V _{DD} Dynamic Impedance	-	-	9	-	kΩ
R _{SW}	SW Driver On-Resistance	I _{SW} =100mA	-	3.0	-	Ω
-	SW Rise Time	1nF load, 15Ω pull-up	-	30	-	ns
-	SW Fall Time	1nF load, 15Ω pull-up	-	20	-	ns
-	SW Switch Off Current	Driver Off	-	5	10	μA

Detail Description

Current Model

Compared to voltage model control, current model control has a current feedback loop. When the voltage of the sample resistor peak current of the primary winding reaches the internal setting value V_{TH} , comparator reverse, register reset and power BJT or MOSFET cut-off. So that to detect and modulate the peak current cycle by cycle could control the output of the power supply. The current feedback has a good linear modulation rate and a fast input and output dynamic impact avoid the pole that the output filter inductance brings and the second class system descends to first class and so it widens the frequency range and optimizes overload protection and short circuit protection.

Startup Current and Under Voltage Lockout

The startup current of RS2030 is set to be very low (3 μ A) so that a large value startup resistor can therefore be used to minimize the power loss. For AC to DC adaptor with universal input range design, a 1.5 M Ω , 1/8 W startup resistor and a 10 μ F/25V V_{DD} hold capacitor could be used.

The turn-on and turn-off threshold of the RS2030 is designed to 5.4V/3.6V. During startup, the hold-up capacitor must be charge to 5.4V through the startup resistor. The hysteresis is implemented to prevent the shutdown from the voltage dip during startup.

Green Power Operation

The power dissipation of switching mode power supply is very important in zero load or light load condition. The major dissipation result from conduction loss \ switching loss and consume of the control circuit. However, all of them related to the switching frequency. There are many difference topologies has been implemented in different chip. The basic operation theory of all these approaches intended to reduce the switching frequency under light-load or no-load condition.

RS2030's green power function adapts PWM \ PFM and CRM combining modulation. The PWM frequency is 65KHz/100KHz in medium or heavy load operation. Through modifying the pulse width, RS2030 could control output voltage. To decrease the standby consumption of the power supply , Orister introduces the Cycle Reset Mode technology : If the feedback current were over 1.5mA, mode controller of RS2030 would reset internal register all the time and cut off the power BJT, while the output voltage is lower than the set value, it would set register, SW pin operating again. Although the frequency of the internal OSC is invariable, the register would reset some pulses so that the practical frequency is decreased at the SW pin.

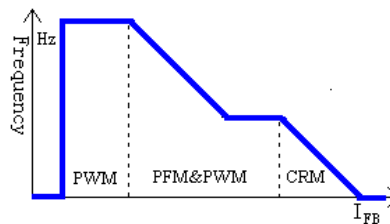

RS2030 Green-Power Function

Internal Synchronized Slope Compensation

Although there are more advantages of the current mode control than conventional voltage mode control, there are still several drawbacks of peak-sensing current-mode converter. Especially the open loop instability when it operates in higher than 50% of the duty-cycle. RS2030 is introduced an internal slope compensation adding voltage ramp to the current sense input voltage for PWM generation to solve this problem. It improves the close loop stability greatly at CCM, prevents the sub-harmonic oscillation and thus reduces the output ripple voltage.

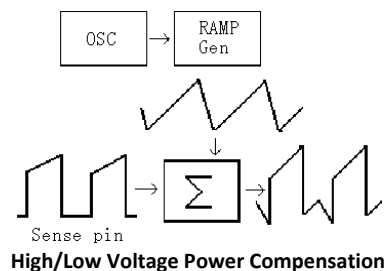

High/Low Voltage Power Compensation

The current flowing by the power BJT has an extra value $\Delta I = \frac{V_{IN}}{L_p} \times T_D$ due to the system delay T_D that the current detected from the sense pin to power BJT cut off in the RS2030 (Among these, V_{IN} is the primary winding voltage of the transformer and L_p is the primary wind inductance, V_{IN} ranges from $85V_{AC}$ to $264V_{AC}$.) To guarantee the output power is a constant for universal input AC voltage, there is a dynamic peak limit circuit to compensate the system delay T_D that the system delay brings on.

Soft Start

The V_{DD} pin of the RS2030 is the power supply voltage pin and the feedback pin, so the duty cycle will be increase with V_{DD} voltage decreasing. The soft start performance have been implemented by increasing the duty cycle in starting.

Leading-edge Blanking (LEB)

Each time the power BJT is switched on, a turn-on spike will inevitably occur at the sense pin, which would disturb the internal signal from the sampling of the R_{SENSE} . There is a 250ns leading edge blanking time built in to avoid the effect of the turn-on spike and the power BJT cannot be switched off during this time. So that the conventional external RC filtering on sense input is no longer required.

Short Circuit Protection (SCP)

When the output circuit is shorted, the restart time of the RS2030 and the input power will be increased with input voltage increasing, then the power NPN BJT will be hot and destroyed. So the Orister secondary delay circuit has been introduced for decrease the restart time.

TO-92 Dimension

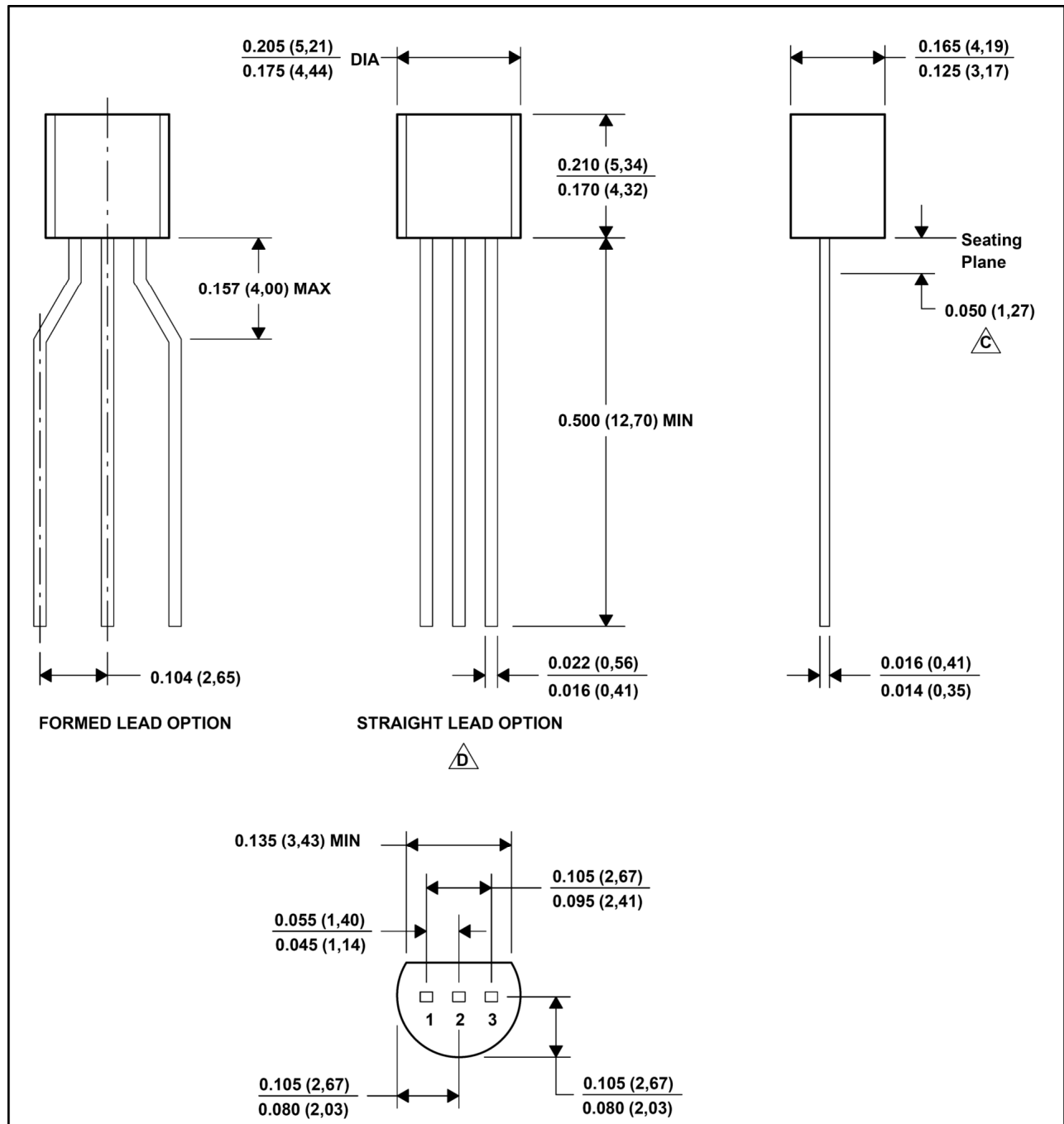

NOTES:

- All linear dimensions are in inches (millimeters).
- This drawing is subject to change without notice.
- Lead dimensions are not controlled within this area.
- Falls within JEDEC TO-226 variation AA (TO-226 replaces TO-92)
- Shipping Method:
 - Straight lead option available in bulk pack only.
 - Formed lead option available in tape & reel or ammo pack.

Soldering Methods for Orister's Products

1. Storage environment: Temperature=10°C~35°C Humidity=65/±15/
2. Reflow soldering of surface-mount devices

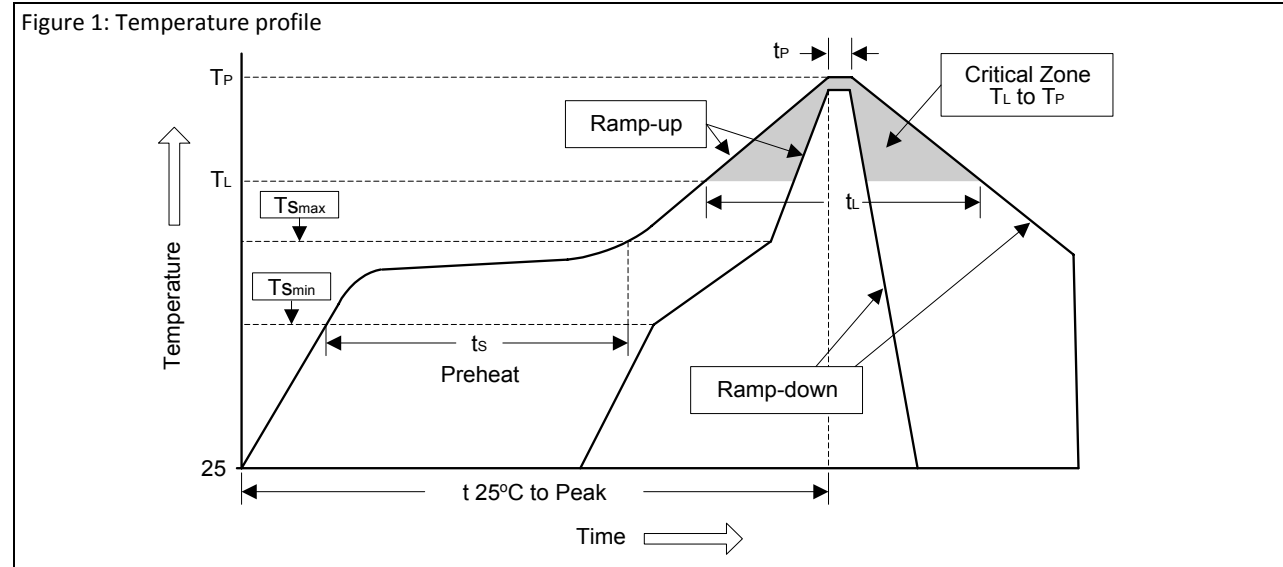

Profile Feature	Sn-Pb Eutectic Assembly	Pb-Free Assembly
Average ramp-up rate (T_L to T_P)	<3°C/sec	<3°C/sec
Preheat		
- Temperature Min (T_{smin})	100°C	150°C
- Temperature Max (T_{smax})	150°C	200°C
- Time (min to max) (t_s)	60~120 sec	60~180 sec
T_{smax} to T_L		
- Ramp-up Rate	<3°C/sec	<3°C/sec
Time maintained above:		
- Temperature (T_L)	183°C	217°C
- Time (t_L)	60~150 sec	60~150 sec
Peak Temperature (T_P)	240°C +0/-5°C	260°C +0/-5°C
Time within 5°C of actual Peak Temperature (t_p)	10~30 sec	20~40 sec
Ramp-down Rate	<6°C/sec	<6°C/sec
Time 25°C to Peak Temperature	<6 minutes	<8 minutes

3. Flow (wave) soldering (solder dipping)

Products	Peak temperature	Dipping time
Pb devices.	245°C ±5°C	5sec ±1sec
Pb-Free devices.	260°C +0/-5°C	5sec ±1sec

Important Notice:**© Orister Corporation**

Orister cannot assume responsibility for use of any circuitry other than circuitry entirely embodied in an Orister product. No circuit patent licenses, copyrights, mask work rights, or other intellectual property rights are implied.

Orister reserves the right to make changes to their products or specifications or to discontinue any product or service without notice. Except as provided in Orister's terms and conditions of sale, Orister assumes no liability whatsoever, and Orister disclaims any express or implied warranty relating to the sale and/or use of Orister products including liability or warranties relating to fitness for a particular purpose, merchantability, or infringement of any patent, copyright or other intellectual property right. In order to minimize risks associated with the customer's applications, adequate design and operating safeguards must be provided by the customer to minimize inherent or procedural hazards. Testing and other quality control techniques are utilized to the extent Orister deems necessary to support this warranty. Specific testing of all parameters of each device is not necessarily performed.

Orister and the Orister logo are trademarks of Orister Corporation. All other brand and product names appearing in this document are registered trademarks or trademarks of their respective holders.