

\*\*\*\*\*  
**TRM-7000-EMG / TRM-7000C-EMG / TRM-7000A-EMG / TRM-7000AC-EMG**  
**5V / 850 nm / 1.25 Gbps **RoHS Compliant** Optical Multi-Mode Transceiver**  
 \*\*\*\*\*

**FEATURES**

- | Duplex SC Multi-Mode Transceiver
- | Compliant with IEEE-802.3z 1000BASE-SX
- | Industry Standard 1 x 9 Footprint
- | 850 nm VCSEL Transmission
- | 0 to 70°C Operating: TRM-7000-EMG
- | -20 to 85°C Operating: TRM-7000A-EMG
- | Single +5 V Power Supply
- | **RoHS Compliant**
- | 300 meter with 62.5/125 μm MMF
- | 500 meter with 50/125 μm MMF
- | LVPECL Signal Detect Output: TRM-7000-EMG
- | LVTTTL Signal Detect Output: TRM-7000C-EMG
- | Wave Solderable and Aqueous Washable
- | Class 1 Laser International Safety Standard IEC 60825-1 Compliant

**APPLICATIONS**

- | Switch to Switch Interface
- | High Speed Interface for File Servers
- | High Performance Desktops

**DESCRIPTION**

The TRM-7000-EMG series multi-mode transceivers is low power, high performance module for bi-directional serial optical data communications such Gigabit Ethernet and Fibre Channel. This module is designed for multi-mode fiber and operates at a nominal wavelength of 850 nm. The transmitter section uses a multiple quantum well VCSEL and is a class 1 laser compliant according to International Safety Standard IEC 60825-1. The receiver section uses an integrated GaAs detector preamplifier (IDP) mounted in an optical header and a limiting post-amplifier IC. A PECL logic interface simplifies interface to external circuitry.

**LASER SAFETY**

This multi-mode transceiver is a Class 1 laser product. It complies with IEC 60825-1 and FDA 21 CFR 1040.10 and 1040.11. The transceiver must be operated within the specified temperature and voltage limits. The optical ports of the module shall be terminated with an optical connector or with a dust plug

**ORDER INFORMATION**

P/No.	Distance (m)	Wavelength (nm)	Voltage (V)	Package	Temp. (°C)	TX Power (dBm)	RX Sens. (dBm)	Signal Detect	RoHS Compliant
TRM-7000-EMG	300 / 500*	850	3.3	1X9 SC	0 to 70	-4 to -9.5	-18	LVPECL	Y
TRM-7000C-EMG	300 / 500*	850	3.3	1X9 SC	0 to 70	-4 to -9.5	-18	LVTTTL	Y
TRM-7000A-EMG	300 / 500*	850	3.3	1X9 SC	-20 to 85	-4 to -9.5	-18	LVPECL	Y
TRM-7000AC-EMG	300 / 500*	850	3.3	1X9 SC	-20 to 85	-4 to -9.5	-18	LVTTTL	Y

Note: Distance: 300 m for 62.5/125 μm MMF, 500 m for 50/125 μm MMF

Absolute Maximum Ratings					
Parameter	Symbol	Min	Max	Units	Notes
Storage Temperature	T <sub>stg</sub>	-40	85	°C	
Operating Temperature	T <sub>opr</sub>	0 -20	70 85	°C	TRM-7000 TRM-7000A
Soldering Temperature	---		260	°C	10 seconds on leads only
Power Supply Voltage	V <sub>cc</sub>	-0.5	6	V	
Input Voltage	---	GND	V <sub>cc</sub>	V	
Output Current	I <sub>out</sub>	0	30	mA	

Recommended Operating Conditions					
Parameter	Symbol	Min	Typ	Max	Units
Power Supply Voltage	V <sub>cc</sub>	4.75	5	5.25	V
Operating Temperature	T <sub>opr</sub>	0 -20		70 85	°C / TRM-7000 °C / TRM-7000A
Data Rate			1250		Mb/s

Transmitter Specifications (0°C < T <sub>opr</sub> < 70°C, 4.75V < V <sub>cc</sub> < 5.25V)						
Parameter	Symbol	Min	Typ	Max	Units	Notes
<b>Optical</b>						
Optical Transmit Power 62.5/125 μm, NA=0.275 Fiber	P <sub>o</sub>	-9.5	---	-4	dBm	
Optical Transmit Power 50/125 μm, NA=0.20 Fiber	P <sub>o</sub>	-9.5	---	-4	dBm	
Output Center Wavelength	λ	830	850	860	nm	
Output Spectrum Width	Δλ	---	---	0.85	nm	RMS (σ)
Extinction Ratio	E <sub>R</sub>	9	---	---	dB	
Output Eye	Compliant with IEEE 802.3z					
Optical Rise Time	t <sub>r</sub>			0.26	ns	20% to 80% Values
Optical Fall Time	t <sub>f</sub>			0.26	ns	20% to 80% Values
Relative Intensity Noise	RIN			-117	dB/Hz	
Total Jitter	TJ			227	ps	
Coupled Power Ratio	CPR	9			dB	
<b>Electrical</b>						
Power Supply Current	I <sub>cc</sub>			120	mA	1
Data Input Current – Low	I <sub>IL</sub>	-350			μA	
Data Input Current – High	I <sub>IH</sub>			350	μA	
Differential Input Voltage	V <sub>IH</sub> - V <sub>IL</sub>	300			mV	
Data Input Voltage – Low	V <sub>IL</sub> - V <sub>CC</sub>	-2.0		-1.58	V	2
Data Input Voltage -- High	V <sub>IH</sub> - V <sub>CC</sub>	-1.1		-0.74	V	2

1. Maximum current is specified at V<sub>cc</sub> = Maximum @ maximum temperature.
2. These inputs are compatible with 10K, 10KH and 100K ECL and LVPECL inputs.

Receiver Specifications (0°C < Topr < 70°C, 4.75 V < Vcc < 5.25V)						
Parameter	Symbol	Min	Typ	Max	Units	Notes
<b>Optical</b>						
Sensitivity	---	---	---	-18	dBm	1
Maximum Input Power	Pin	0		---	dBm	
Signal Detect -- Asserted	Pa	---	---	-18	dBm	Transition: low to high
Signal Detect -- Deasserted	Pd	-30	---	---	dBm	Transition: high to low
Signal Detect -- Hysteresis			3		dB	
Wavelength of Operation		770	---	860	nm	
<b>Electrical</b>						
Power Supply Current	Icc			100	mA	2
Data Output Voltage – Low	V <sub>OL</sub> - V <sub>CC</sub>	-2.0		-1.58	V	3
Data Output Voltage – High	V <sub>OH</sub> - V <sub>CC</sub>	-1.1		-0.74	V	3
Signal Detect Output Voltage -- Low	V <sub>OL</sub> - V <sub>CC</sub>	-2.0		-1.58	V	TRM-7000
Signal Detect Output Voltage -- High	V <sub>OH</sub> - V <sub>CC</sub>	-1.1		-0.74	V	
Signal Detect Output Voltage -- Low	V <sub>SDL</sub>			0.5	V	TRM-7000C
Signal Detect Output Voltage -- High	V <sub>SDH</sub>	2.0			V	

1. Minimum sensitivity and saturation levels at BER=1E-12 for a 2<sup>7</sup>-1 PRBS at ER= 9 dB. For example, an OMA of 22 μW is approximately equal to an average power of -18.4 dBm, average with an Extinction ratio of 9 dB.
2. The current excludes the output load current.
3. These outputs are compatible with 10K, 10KH and 100K ECL and PECL outputs.

## CONNECTION DIAGRAM

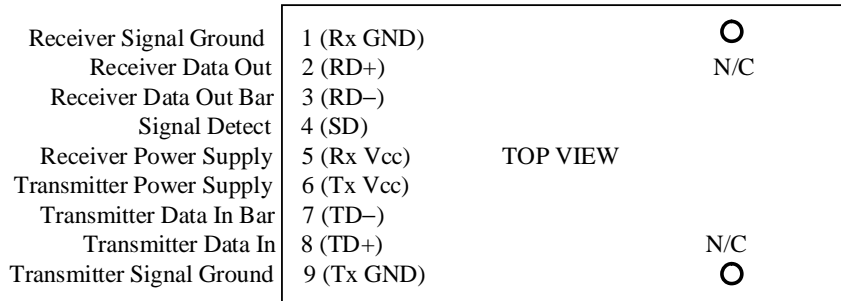

PIN	Symbol	Notes
1	Rx GND	Directly connect this pin to the receiver ground plane
2	RD+	See recommended circuit schematic
3	RD-	See recommended circuit schematic
4	SD	Active high on this indicates a received optical signal
5	Rx Vcc	+5V dc power for the receiver section
6	Tx Vcc	+5V dc power for the transmitter section
7	TD-	See recommended circuit schematic
8	TD+	See recommended circuit schematic
9	Tx GND	Directly connect this plan to the transmitter ground plane

RECOMMENDED CIRCUIT SCHEMATIC

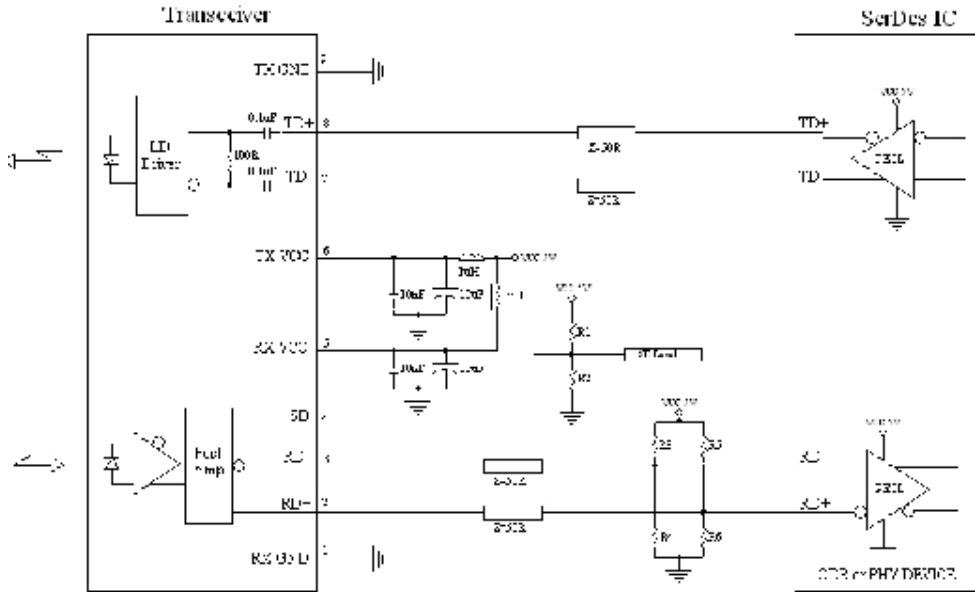

For TTL SD Level R1=R2=N.C., R3=R5=82R, R4=R6=130R  
 For PECL SD Level R1 R3 R5 82R, R2 R4 R6 130R

The split-load terminations for ECL signals need to be located at the input of devices receiving those ECL signals. The power supply filtering is required for good EMI performance. Use short tracks from the inductor L1/L2 to the module Rx Vcc and Tx Vcc. A GND plane under the module is required for good EMI and sensitivity performance.

PACKAGE DIAGRAM

Units in mm

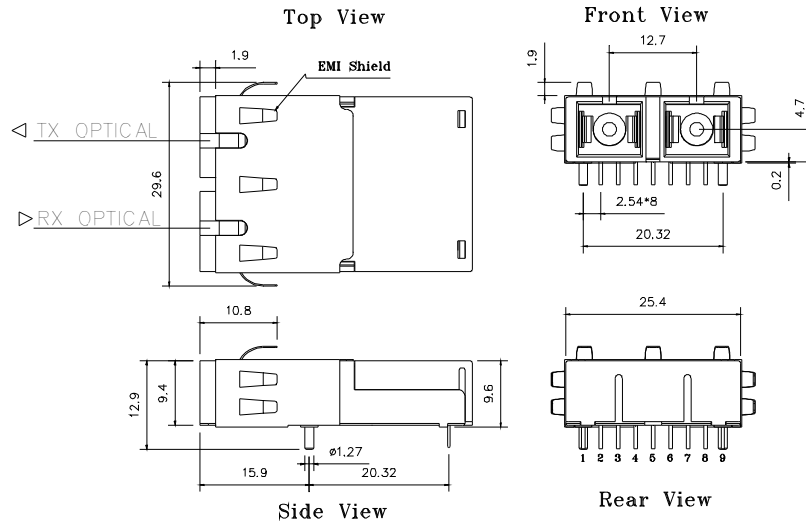

TRM-7000-EMG / TRM-7000C-EMG / TRM-7000A-EMG / TRM-7000AC-EMG

Note: Specifications subject to change without notice.

\*\*\*\*\*  
**OPTOWAY TECHNOLOGY INC.** No.38, Kuang Fu S. Road, Hu Kou, Hsin Chu Industrial Park, Hsin Chu, Taiwan 303  
 Tel: 886-3-5979798 Fax: 886-3-5979737  
 E-mail: sales@optoway.com.tw http://www.optoway.com.tw 10/1/2005 V2.0