

3.3V 2x10 LC connector SFF Gigabit Ethernet 1300 & 1550 nm Laser Transceivers



Features

- ☑ Compliant with IEEE 802.3z Gigabit Ethernet 1000BASE-LX PMD specifications
- ☑ Distance options of 10 km, 25 km, 40 km and 70 km using DFB lasers also available
- ☑ Eye Safe (Class I Laser Safety)
- ☑ Excellent EMI & ESD protection (optional extra EMI shield also available)
- ☑ Multi-sourced 20-pin (2x10) SFF (Small Form Factor) package style
- ☑ Duplex LC optical connector interface
- ☑ Single +3.3 V supply & LV-PECL DATA interface (AC coupling option also available)
- ☑ LV-TTL TX DISABLE input & RX SIGNAL DETECT output

Description

The DTR-1250-SM2-LC and DTR-1250-SM2-LS fiber optic transceivers offer a simple and convenient way to interface 1000BASE-LX Gigabit Ethernet boards running at 1.25 Gbaud to single mode and multimode fiber optic cables. In addition to option "L2" for the 5 km distance specified in IEEE 802.3z standard, five other options with longer distance capability with single mode fibers are offered. In option "L1", a 1300 nm Fabry Perot laser with higher power and narrower spectral width and center wavelength range is used to increase the distance to at least 10 km. In option "L0", an even higher power 1300 nm Fabry Perot laser is used to offer more optical power budget. In option "H3", a 1300 nm DFB laser and a high sensitivity receiver are used to increase the distance to over 25 km or 30 km (assuming worst case fiber loss of 0.4 dB/km and 0.35 dB/km respectively). In option "H5", a 1550 nm DFB laser and a high sensitivity receiver are used to increase the distance to over 35 km or 40 km (assuming worst case fiber loss of 0.3 and 0.25 dB/km respectively). Finally, in option "H7", a high power 1550 nm DFB laser

and an ultra high sensitivity receiver are used to increase the distance to 70 km (assuming fiber loss of 0.2 to 0.25 dB/km). All modules satisfy Class I Laser Safety requirements in accordance with the US FDA/CDRH and international IEC-825 standards.

The transmit and receive functions are contained in a narrow width two-row, 20-pin (2x10) package with a Duplex LC connector interface. The receptacle fits into an RJ-45 form factor outline. The 20-pin configuration is in conformance to a Small Form Factor (SFF) multisource agreement.

The transmitter and receiver DATA interface are differential direct-coupled LV-PECL. An alternate version with AC coupling interface is also available. An LV-TTL Transmitter Disable control input is provided. The receiver Signal Detect output interface is also LV-TTL.

The transceiver operates from a single +3.3V power supply over an operating temperature range of 0°C to +70°C and -40°C to +85°C. The package is made of either *conductive* plastic or metal for excellent EMI shielding.

Absolute Maximum Ratings

Parameter		Symbol	Minimum	Maximum	Units
Storage Temperature		T_{st}	- 40	+ 85	°C
Operating Temperature	"A" option	T_{op}	- 40	+ 85	°C
	"B" option		0	+ 70	
Supply Voltage		V_{CC}	- 0.5	+ 6.0	V
Input Voltage		V_{in}	- 0.5	V_{CC}	V
Output Current		I_O	-	50	mA
Lead Soldering Temperature & Time		-	-	260° C, 10 sec	

DTR-1250-SM2-LC & DTR-1250-SM2-LS

Transmitter Performance Characteristics (over Operating Case Temperature)

All parameters guaranteed only at typical data rate

Parameter		Symbol	Minimum	Typical	Maximum	Units
Data Rate ¹		B	-	1250	-	Mb/s
Optical Output Power ²	L2	P_o	- 11.0	-	- 3.0	dBm
	L1		- 9.0	-	- 3.0	
	L0		- 5.0	-	0	
	H3, H5		- 4.0	-	1.0	
	H7		- 3.0	-	2.0	
Center Wavelength	L2	λ_c	1270	1310	1355	nm
	L1, L0 (0°C to 70° C)		1285	1310	1345	
	L1, L0 (-40° C to 85° C)		1274	1310	1360	
	H3		1280	1310	1335	
	H5, H7		1480	1550	1580	
Spectral Width (RMS) ²	L2	$\Delta\lambda_{RMS}$	-	-	4.0	nm
	L1, L0		-	-	2.5	
Spectral Width (-20dB)		H3, H5, H7	$\Delta\lambda_{20}$	-	-	1.0
Extinction Ratio		P_{hi}/P_{lo}	9	-	-	dB
Deterministic Jitter		DJ	-	-	80	ps
Random Jitter		RJ	-	-	147	ps
Relative Intensity Noise		RIN	-	-	- 120	dB/Hz
Transmitter Output Eye		Compliant with Eye Mask Defined in IEEE 802.3z standard				

¹Data rate ranges from 125Mb/s to 1300Mb/s. However, some degradation may be incurred in overall performance.

²Measured average power coupled into single mode fiber (SMF). For 50 μ m or 62.5 μ m multimode fiber (MMF) operation, the output power is 0.5dB less and is measured after a single mode fiber offset-launch mode-conditioning patch cord as specified in IEEE 802.3z Annex 50.

Receiver Performance Characteristics (over Operating Case Temperature)

All parameters guaranteed only at typical data rate

Parameter		Symbol	Minimum	Typical	Maximum	Units
Data Rate ¹		B	-	1250	-	Mb/s
Minimum Input Optical Power (10 ⁻¹² BER) ²	L2, L1, L0	P_{min}	- 20.0	- 23.0	-	dBm
	H3, H5		- 21.0	- 24.0	-	
	H7		- 23.0	- 26.0	-	
Maximum Input Optical Power (10 ⁻¹² BER) ²		P_{max}	- 3.0	-	-	dBm
Signal Detect Thresholds	Increasing Light Input	L2, L1, L0	-	-	- 20.0	dBm
		H3, H5	-	-	- 21.0	
		H7	-	-	- 23.0	
	Decreasing Light Input		P_{sd-}	- 30.0	-	-
Signal Detect Hysteresis		-	0.5	-	-	dB
Deterministic Jitter		DJ	-	-	170	ps
Random Jitter		RJ	-	-	96	ps
Wavelength of Operation		λ	1100	-	1600	nm
Return Loss		-	12	-	-	dB
Electrical 3dB upper cutoff frequency		-	-	-	1500	MHz
Stressed Receiver Sensitivity		Compliant with IEEE 802.3z standard				

¹Data rate ranges from 125Mb/s to 1300Mb/s. However, some degradation may be incurred in overall performance.

²Measured with 2⁷-1 PRBS at 1250Mb/s at 1300nm wavelength.

Electrical Power Supply Characteristics (over Operating Case Temperature Range)

Parameter		Symbol	Minimum	Typical	Maximum	Units
Supply Voltage		V_{CC}	3.13	3.3	3.47	V
Supply Current ¹	TX	$I_{CC,TX}$	-	80	120	mA
	RX	$I_{CC,RX}$	-	75	100	mA

¹Supply current does not include termination resistor current.

DTR-1250-SM2-LC & DTR-1250-SM2-LS

Transmitter Electrical Interface (over Operating Case Temperature Range)

Parameter	Symbol	Minimum	Typical	Maximum	Units
Input HIGH Voltage	V_{IH}	$V_{CC} - 1.165$	-	$V_{CC} - 0.880$	V
Input LOW Voltage	V_{IL}	$V_{CC} - 1.810$	-	$V_{CC} - 1.475$	V
Data Input Current - HIGH	I_H	-	-	150	μA
Data Input Current - LOW	I_L	0.5	-	-	μA
Transmitter Disable Voltage	V_{DIS}	2.0	-	V_{CC}	V
Transmitter Enable Voltage	V_{EN}	0	-	0.8	V
Differential Bias Monitor Voltage ($T_a = 25^\circ C$)	$V_{BM+} - V_{BM-}$	0.02	-	0.12	V
Differential Back Facet Monitor Voltage	$V_{FM+} - V_{FM-}$	-	100	-	mV

Receiver Electrical Interface (over Operating Case Temperature Range)

Parameter	Symbol	Minimum	Typical	Maximum	Units
Output HIGH Voltage (LV-PECL) ¹	V_{OH}	$V_{CC} - 1.10$	-	$V_{CC} - 0.70$	V
Output LOW Voltage (LV-PECL) ¹	V_{OL}	$V_{CC} - 1.95$	-	$V_{CC} - 1.50$	V
Output HIGH Voltage (LV-TTL)	V_{OH}	2.4	-	V_{CC}	
Output LOW Voltage (LV-TTL)	V_{OL}	0	-	0.8	
Output Current	I_O	-	-	25	mA

¹With 50 ohm terminated to $V_{CC} - 2$ volts.

Application Notes

Transmitter: When the DATA+ input is at logic HIGH and DATA- input is at logic LOW, the Laser Diode is ON; and vice versa. The transmitter is normally enabled (i.e. when the TX DISABLE control input is not connected). When the TX DISABLE control input voltage is higher than $V_{CC} - 1.3$ V, the laser is turned off independent of the input data.

The transmitter incorporates an Average Power Control (APC) loop to stabilize the transmitter average optical output power against temperature variation. The APC loop always acts to keep the transmitter average optical output power at a constant value. Therefore, when the input data is all continuous “zeroes” or all continuous “ones”, the transmitter optical output power is a constant level equal to the nominal average optical output power (not at the “OFF” level or at the “ON” level).

Receiver: Both differential DATA+ and DATA- outputs are LV-PECL levels requiring proper termination (see recommended interface circuits). For optimum performance, both outputs should be terminated in the same manner, even if only one is used.

The Signal Detect circuit monitors the level of the incoming optical signal and generates a logic LOW signal when insufficient photocurrent is produced. If the SIGNAL DETECT output is LV-TTL level, no termination is required. If the SIGNAL DETECT output is LV-PECL level, a termination resistor of 160 ohms to GND is required.

Pin Assignments

PIN	FUNCTION	PIN	FUNCTION
1	VPD	11	$V_{CC}TX$
2	RX GND	12	TX GND
3	RX GND	13	TX DISABLE
4	N/C	14	TD+ (TX DATA IN +)
5	N/C	15	TD- (TX DATA IN -)
6	RX GND	16	TX GND
7	$V_{CC}RX$	17	BM - (BIAS MONITOR -)
8	SD (RX SIGNAL DETECT)	18	BM + (BIAS MONITOR +)
9	RD- (RX DATA OUT-)	19	FM- (FACET MONITOR -)
10	RD+ (RX DATA OUT+)	20	FM + (FACET MONITOR +)

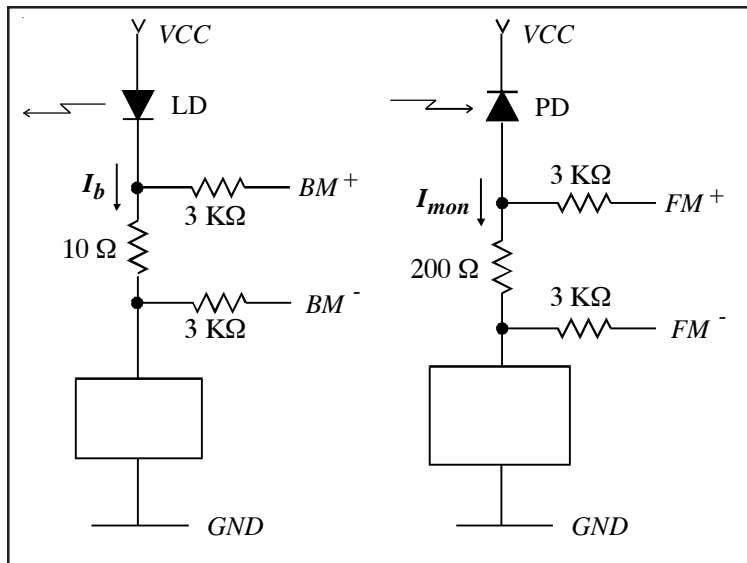

DTR-1250-SM2-LC & DTR-1250-SM2-LS

Interface circuit: Three options for interface circuit are shown here: two with DC coupling and one with AC coupling.

The power supply line should be well-filtered. All 0.1 μF power supply bypass capacitors should be as close to the DTR transceiver module as possible. The two front GND posts (mounting studs) should be grounded to Chassis Ground. If Chassis Ground is not available, they should be connected to Circuit Ground.

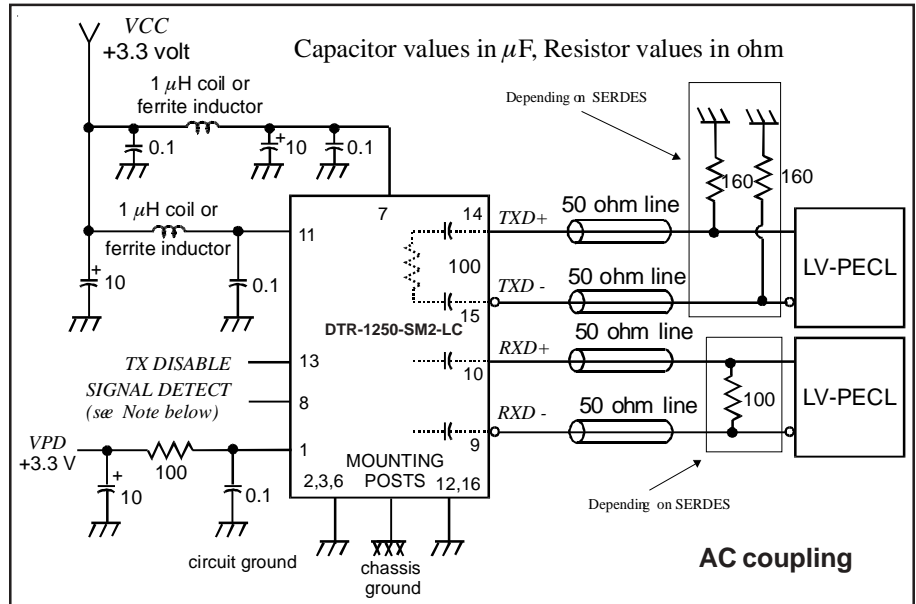
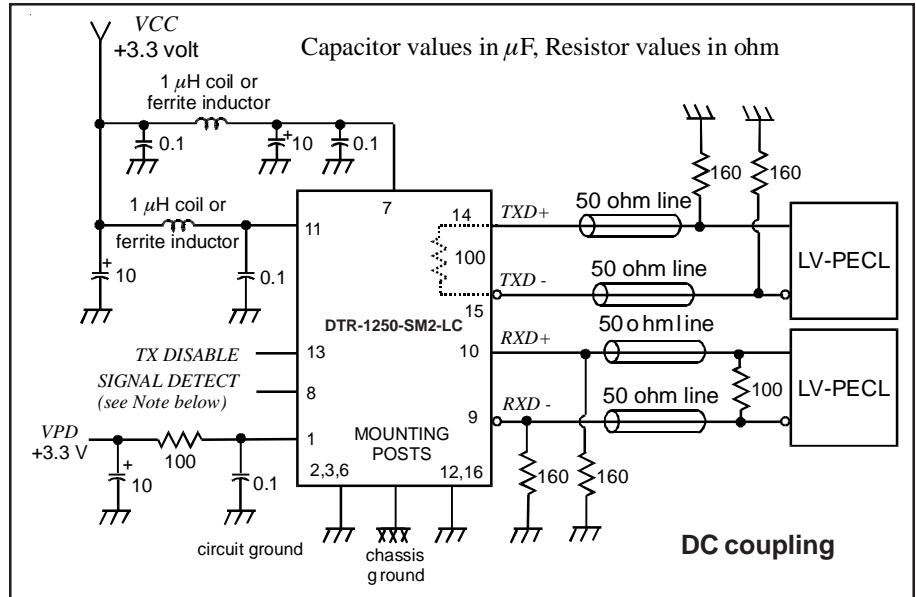

Ordering Information

Model (DC-coupled, Metal Package)	EMI Shield	Distance (notes on p.1 & 3)
DTR-1250-SM2-LC-L2-M	NO	1000Base-LX (5 km)
DTR-1250-SM2-LC-L1-M DTR-1250-SM2-LC-L0-M	NO	Longer (10 km)
DTR-1250-SM2-LC-H3-M	NO	1300 nm DFB (25 km)
DTR-1250-SM2-LC-H5-M	NO	1550 nm DFB (40 km)
DTR-1250-SM2-LC-H7-M	NO	1550 nm DFB (70 km)

Model (DC-coupled, Metal Package)	EMI Shield	Distance (notes on p.1 & 3)
DTR-1250-SM2-LS-L2-M	YES	1000Base-LX (5 km)
DTR-1250-SM2-LS-L1-M DTR-1250-SM2-LS-L0-M	YES	Longer (10 km)
DTR-1250-SM2-LS-H3-M	YES	1300 nm DFB (25 km)
DTR-1250-SM2-LS-H5-M	YES	1550 nm DFB (40 km)
DTR-1250-SM2-LS-H7-M	YES	1550 nm DFB (70 km)

- For AC-coupled modules, please add suffix "AC" to the above Model Names.
For example, the AC-coupled version of DTR-1250-SM-LC-L2 is DTR-1250-SM-LC-L2-AC.
- For Plastic Package modules, please remove suffix "M" to the above Model Names.
For example, the Plastic Package version of DTR-1250-SM-LC-L2-M is DTR-1250-SM-LC-L2-AC-M are DTR-1250-SM-LC-L2 and DTR-1250-SM-LC-L2-AC.
- For Industrial temperature, please add suffix "A" to the above Model Names.
For example, Industrial temperature version of DTR-1250-SM2-LC-L2 and DTR-1250-SM2-LC-L2-AC are DTR-1250-SM2-LC-A-L2-M and DTR-1250-SM2-LC-A-L2-AC-M
- The H3 & H7 options with "A" temperature range is only available from -25°C to +85°C.

DTR-xxx-SM2-LC & DTR-xxx-SM2-LS

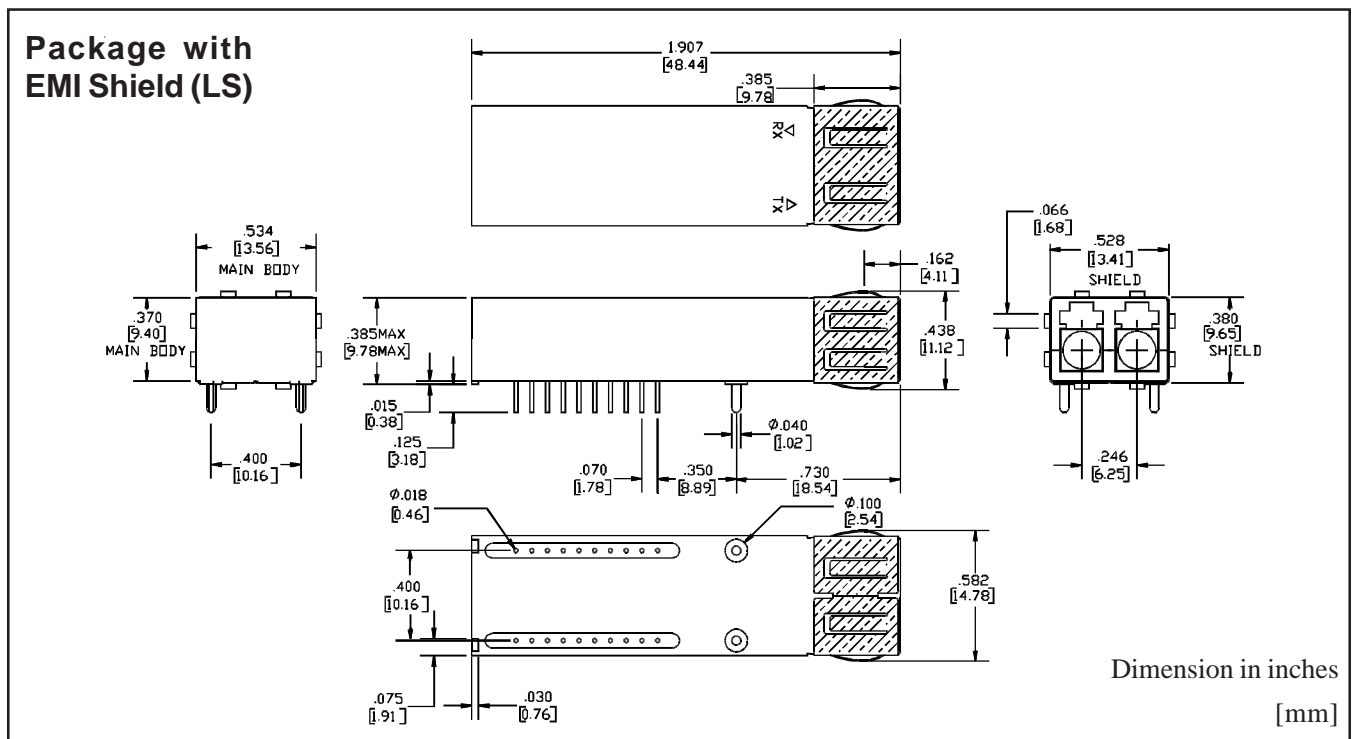
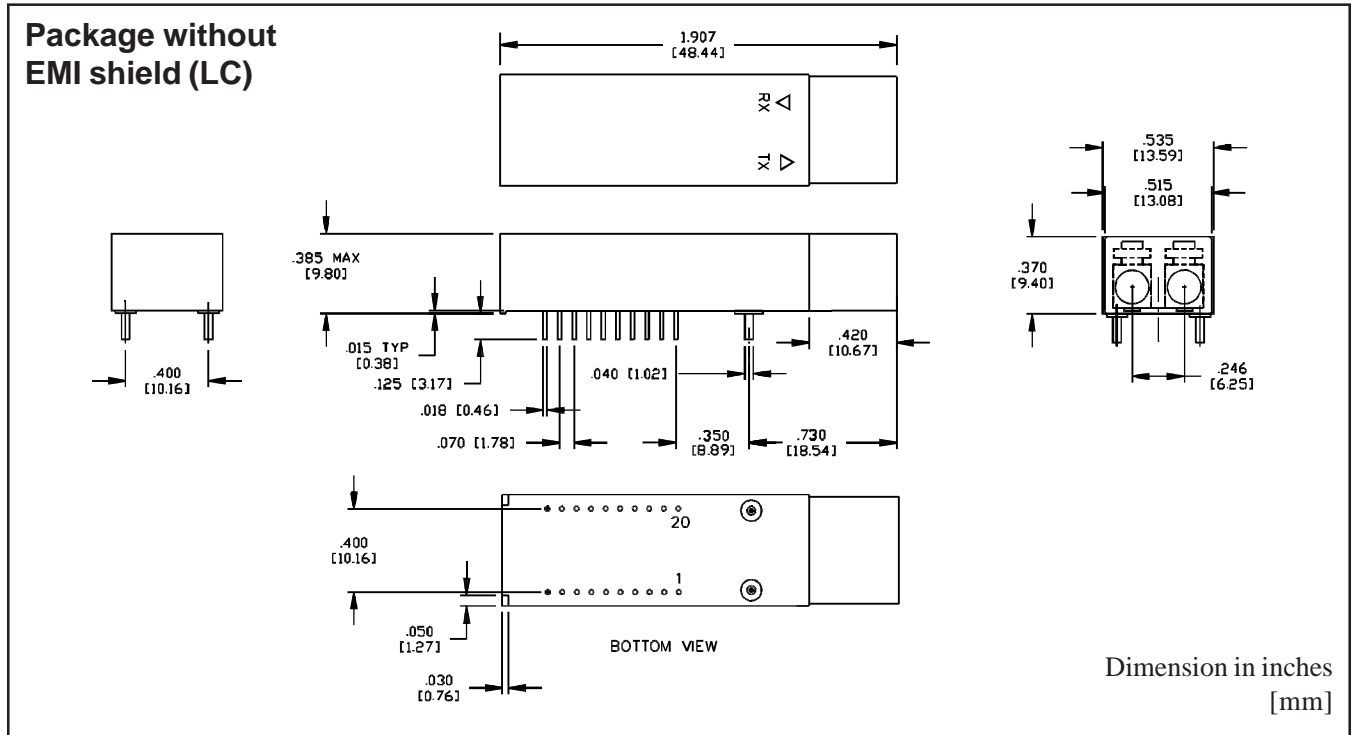

Laser Safety: All transmitters are Class I Laser products per FDA/CDRH and IEC-825 standards. They must be operated under specified operating conditions.

Optical Communication Products, Inc.

DATE OF MANUFACTURE:

MANUFACTURED IN THE USA

This product complies with
21 CFR 1040.10 and 1040.11

Meets Class I Laser Safety Requirements

Optical Communication Products, Inc.

20961 Knapp Street, Chatsworth, CA 91311, Tel.: 818-701-0164, FAX: 818-701-1468, <http://www.ocp-inc.com>

Optical Communication Products, Inc. reserves the right to make changes in equipment design or specifications without notice. Information supplied by Optical Communication Products, Inc. is believed to be accurate and reliable. However, no responsibility is assumed by Optical Communication Products, Inc. for its use nor for any infringements of third parties which may result from its use. No license is granted by implication or otherwise under any patent right of Optical Communication Products, Inc.