



SANYO Semiconductors

DATA SHEET

An ON Semiconductor Company

LE24L042CS-B — CMOS IC Two Wire Serial Interface EEPROM (4k EEPROM)

Overview

The LE24L042CS-B is a 2-wire serial interface EEPROM. It realizes high speed and a high level reliability by incorporating SANYO's high performance CMOS EEPROM technology. This device is compatible with I²C memory protocol, therefore it is best suited for application that requires small-scale re-writable nonvolatile parameter memory.

Functions

- Capacity: 4k bits (512 × 8 bits)
- Single supply voltage: 1.7V to 3.6V
- Interface: Two wire serial interface (I²C Bus*)
- Operating clock frequency: 400kHz
- Low power consumption
 - : Standby: 2μA (max)
 - : Active (Read): 0.5mA (max)
- Automatic page write mode: 16 Bytes
- Read mode: Sequential read and random read
- Erase/Write cycles: 10⁵ cycles
- Data Retention: 20 years
- High reliability: Adopts SANYO's proprietary symmetric memory array configuration (USP6947325)
 - Noise filters connected to SCL and SDA pins
 - Incorporates a feature to prohibit write operations under low voltage conditions.

* I²C Bus is a trademark of Philips Corporation.

* This product is licensed from Silicon Storage Technology, Inc. (USA), and manufactured and sold by SANYO Semiconductor Co., Ltd.

■ Any and all SANYO Semiconductor Co.,Ltd. products described or contained herein are, with regard to "standard application", intended for the use as general electronics equipment. The products mentioned herein shall not be intended for use for any "special application" (medical equipment whose purpose is to sustain life, aerospace instrument, nuclear control device, burning appliances, transportation machine, traffic signal system, safety equipment etc.) that shall require extremely high level of reliability and can directly threaten human lives in case of failure or malfunction of the product or may cause harm to human bodies, nor shall they grant any guarantee thereof. If you should intend to use our products for new introduction or other application different from current conditions on the usage of automotive device, communication device, office equipment, industrial equipment etc. , please consult with us about usage condition (temperature, operation time etc.) prior to the intended use. If there is no consultation or inquiry before the intended use, our customer shall be solely responsible for the use.

■ Specifications of any and all SANYO Semiconductor Co.,Ltd. products described or contained herein stipulate the performance, characteristics, and functions of the described products in the independent state, and are not guarantees of the performance, characteristics, and functions of the described products as mounted in the customer's products or equipment. To verify symptoms and states that cannot be evaluated in an independent device, the customer should always evaluate and test devices mounted in the customer's products or equipment.

SANYO Semiconductor Co., Ltd.

<http://semicon.sanyo.com/en/network>

LE24L042CS-B

Package Dimensions

unit : mm (typ)

3433

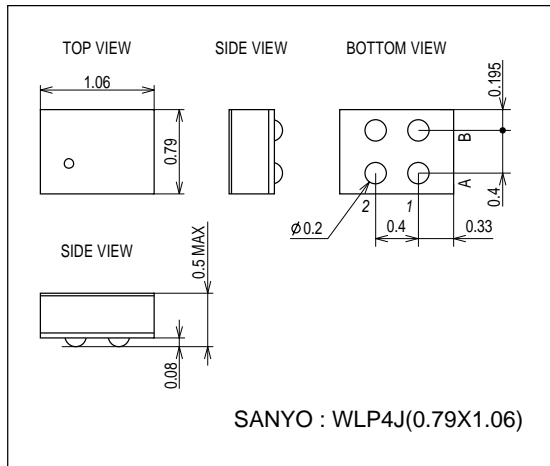

Pin Assignment

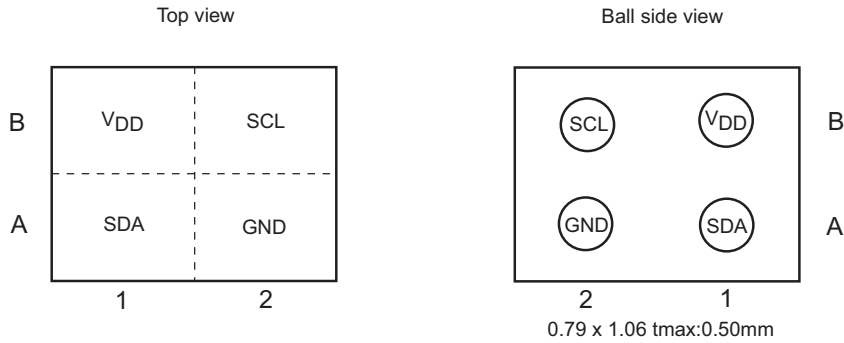

Pin Descriptions

PIN.A1	SDA	Serial data input/output
PIN.A2	GND	Ground
PIN.B1	V _{DD}	Power supply
PIN.B2	SCL	Serial clock input

Block Diagram

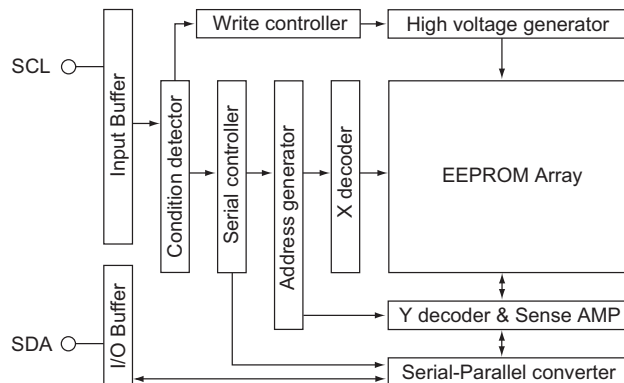

LE24L042CS-B

Specifications

Absolute Maximum Ratings

Parameter	Symbol	Conditions	Ratings	Unit
Supply voltage	V_{CC}		-0.5 to +4.6	V
DC input voltage			-0.5 to $V_{DD}+0.5$	V
Over-shoot voltage		Below 20ns	-1.0 to $V_{DD}+1.0$	V
Storage temperature	T_{stg}		-65 to +150	°C

Note: If an electrical stress exceeding the maximum rating is applied, the device may be damaged.

Operating Conditions

Parameter	Symbol	Conditions	Ratings	Unit
Operating supply voltage			1.7 to 3.6	V
Operating temperature			-40 to +85	°C

DC Electrical Characteristics

Parameter	Symbol	Conditions	$V_{DD}=1.7V$ to $3.6V$			Unit
			min	typ	max	
Supply current at reading	I_{CC1}	$f=400kHz$			0.5	mA
Supply current at writing	I_{CC2}	$f=400kHz, t_{WC}=10ms$			3	mA
Standby current	I_{SB}	$V_{IN}=V_{DD}$ or GND			2	μA
Input leakage current	I_{LI}	$V_{IN}=GND$ to V_{DD}	-2.0		+2.0	μA
Output leakage current (SDA)	I_{LO}	$V_{OUT}=GND$ to V_{DD}	-2.0		+2.0	μA
Input low voltage	V_{IL}				$V_{DD} \cdot 0.2$	V
Input low voltage (CMOS)	V_{ILC}				0.2	V
Input high voltage	V_{IH}		$V_{DD} \cdot 0.8$			V
Input high voltage (CMOS)	V_{IHC}		$V_{DD} \cdot 0.2$			V
Output low voltage	V_{OL}	$I_{OL}=0.7mA, V_{DD}=1.7V$			0.2	V
		$I_{OL}=1.0mA, V_{DD}=2.5V$			0.4	V

Capacitance/ $T_a=25^\circ C, f=1MHz$

Parameter	Symbol	Conditions	max	Unit
In/Output pin capacitance	$C_{I/O}$	$V_{I/O}=0V$ (SDA)	10	pF
Input pin capacitance	C_I	$V_{IN}=0V$ (other than SDA)	10	pF

Note: This parameter is sampled and not 100% tested.

AC Electric Characteristics

Input pulse level	$0.1 \times V_{DD}$ to $0.9 \times V_{DD}$
Input pulse rise / fall time	20ns
Output detection voltage	$0.5 \times V_{DD}$
Output load	50pF+Pull up resistor 3.0k Ω

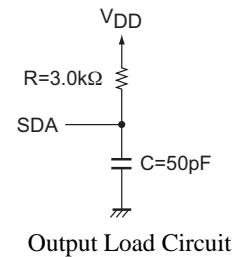

LE24L042CS-B

Parameter	Symbol	$V_{DD}=1.7V$ to $3.6V$			unit
		min	typ	max	
Slave mode SCL clock frequency	f_{SCLS}	0		400	kHz
SCL clock low time	t_{LOW}	1200			ns
SCL clock high time	t_{HIGH}	600			ns
SDA output delay time	t_{AA}	100		900	ns
SDA data output hold time	t_{DH}	100			ns
Start condition setup time	$t_{SU.STA}$	600			ns
Start condition hold time	$t_{HD.STA}$	600			ns
Data in setup time	$t_{SU.DAT}$	100			ns
Data in hold time	$t_{HD.DAT}$	0			ns
Stop condition setup time	$t_{SU.STO}$	600			ns
SCL SDA rise time	t_R			300	ns
SCL SDA fall time	t_F			300	ns
Bus release time	t_{BUF}	1200			ns
Noise suppression time	t_{SP}			100	ns
Write cycle time	t_{WC}			10	ms

Bus Timing

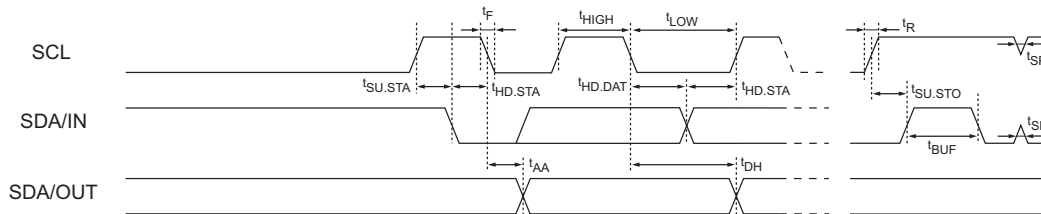

Write Timing

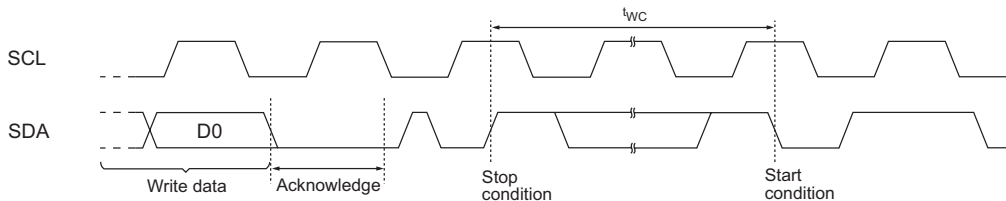

Pin Functions

SCL (serial clock input) pin

The SCL pin is a serial clock input pin that processes signals at the rising and falling edges of SCL clock signals. This pin must be pulled up by a resistor to the V_{DD} level and wired-ORed with an open drain (or open collector) output device for use.

SDA (serial data input/output) pin

The SDA pin is used to transfer serial data to the input/output, and it consists of a signal input pin and n-channel transistor open drain output pin.

Like the SCL pin, the SDA pin must be pulled up by a resistor to the V_{DD} level and wired-ORed with an open drain (or open collector) output device for use.

Functional Description

1 Start condition

When the SCL line is at the high level, the start condition is established by changing the SDA line from high to low. The operation of the EEPROM as a slave starts in the start condition.

2 Stop condition

When the SCL line is at the high level, the stop condition is established by changing the SDA line from low to high. When the device is set up for the read sequence, the read operation is suspended when the stop condition is received, and the device is set to standby mode. When it is set up for the write sequence, the capture of the write data is ended when the stop condition is received, and the EEPROM internal write operation is started.

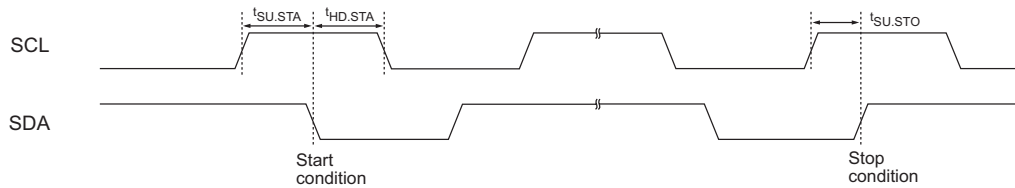

3 Data transfer

Data is transferred by changing the SDA line while the SCL line is low. When the SDA line is changed while the SCL line is high, the resulting condition will be recognized as the start or stop condition.

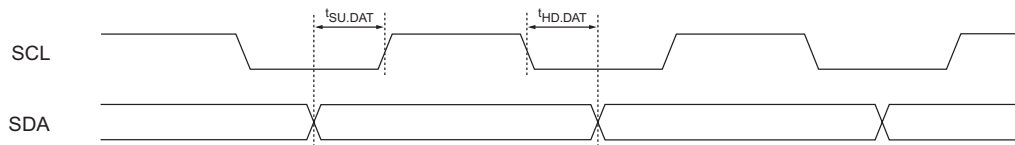

4 Acknowledge

During data transfer, 8 bits are transferred in succession, and then in the ninth clock cycle period the device on the system bus receiving the data sets the SDA line to low, and sends the acknowledge signal indicating that the data has been received. The acknowledge signal is not sent during an EEPROM internal write operation.

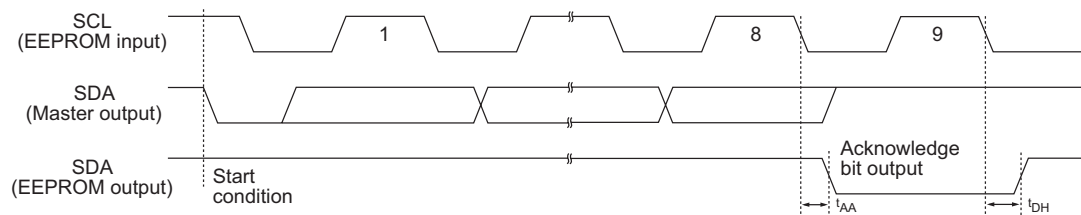

6 EEPROM write operation

6-1. Byte writing

When the EEPROM receives the 7-bit device address and write command code “0” after the start condition, it generates an acknowledge signal. After this, if it receives the 8-bit word address, generates an acknowledge signal, receives the 8-bit write data, generates an acknowledge signal and then receives the stop condition, the internal write operation of the EEPROM in the designated memory address will start. Rewriting is completed in the t_{WC} period after the stop condition. During an EEPROM internal write operation, no input is accepted and no acknowledge signals are generated.

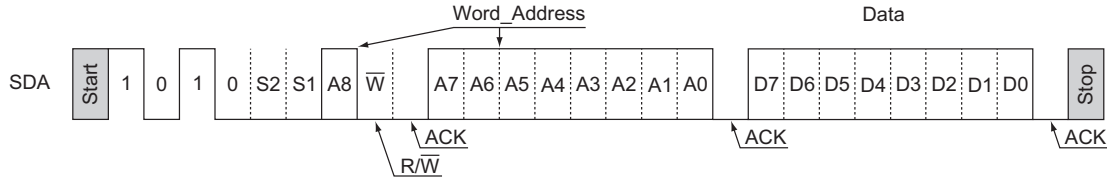

6-2. Page writing

This product enables pages with up to 16 bytes to be written. The basic data transfer procedure is the same as for byte writing: Following the start condition, the 7-bit device address and write command code “0,” word address (n), and data (n) are input in this order while confirming acknowledge “0” every 9 bits. The page write mode is established if, after data (n) is input, the write data (n+1) is input without inputting the stop condition. After this, the write data equivalent to the largest page size can be received by a continuous process of repeating the receiving of the 8-bit write data and generating the acknowledge signals.

At the point when the write data (n+1) has been input, the lower 4 bits (A0-A3) of the word addresses are automatically incremented to form the (n+1) address. In this way, the write data can be successively input, and the word address on the page is incremented each time the write data is input. If the write data exceeds 16 bytes or the last address of the page is exceeded, the word address on the page is rolled over. Write data will be input into the same address two or more times, but in such cases the write data that was input last will take effect. Finally, the EEPROM internal write operation corresponding to the page size for which the write data is received starts from the designated memory address when the stop condition is received.

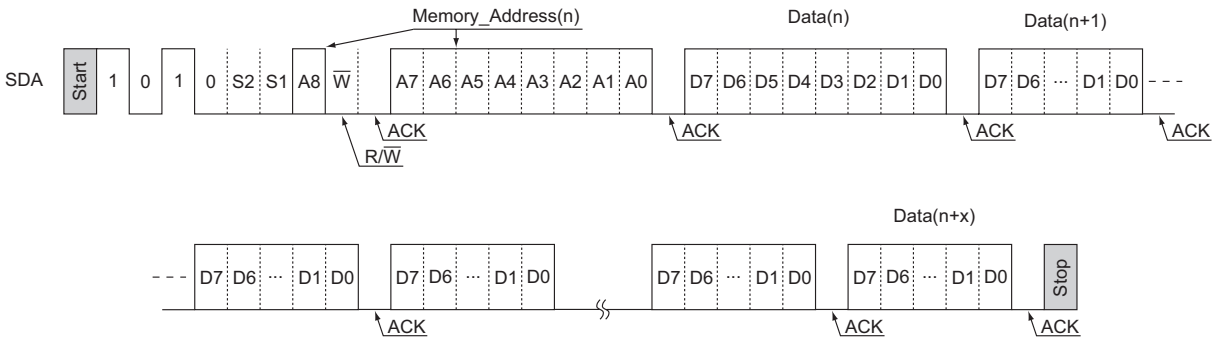

6-3. Acknowledge polling

Acknowledge polling is used to find out when the EEPROM internal write operation is completed. When the stop condition is received and the EEPROM starts rewriting, all operations are prohibited, and no response can be given to the signals sent by the master device. Therefore, in order to find out when the EEPROM internal write operation is completed, the start condition, device address and write command code are sent from the master device to the EEPROM (slave device), and the response of the slave device is detected.

In other words, if the slave device does not send the acknowledge signal, it means that the internal write operation is in progress; conversely, if it does send the acknowledge signal, it means that the internal write operation has been completed.

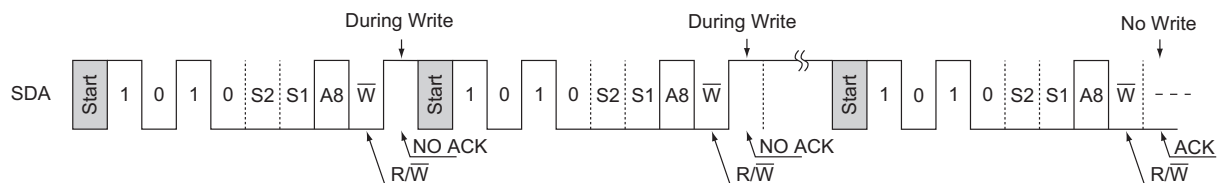

7 EEPROM read operations

7-1. Current address reading

The address equivalent to the memory address accessed last +1 is held as the internal address of the EEPROM for both write* and read operations. Therefore, provided that the master device has recognized the position of the EEPROM address pointer, data can be read from the memory address with the current address pointer without specifying the word address.

As with writing, current address reading involves receiving the 7-bit device address and read command code “1” following the start condition, at which time the EEPROM generates an acknowledge signal. After this, the 8-bit data of the (n+1) address is output serially starting with the highest bits. After the 8 bits have been output, by not sending an acknowledge signal and inputting the stop condition, the EEPROM completes the read operation and is set to standby mode.

If the previous read address is the last address, the address for the current address reading is rolled over to become address 0.

*: If the write data is 1 or more bytes but less than 16 bytes, the current address after page writing is the address equivalent to the number of bytes to be written in the specified word address +1. If the write data is 16 or more bytes, it is the designated word address. If the last address (A3-A0=1111b) on the page has been designated by byte write as the word address, the first address (A3-A0=0000b) on the page serves as the internal address after writing.

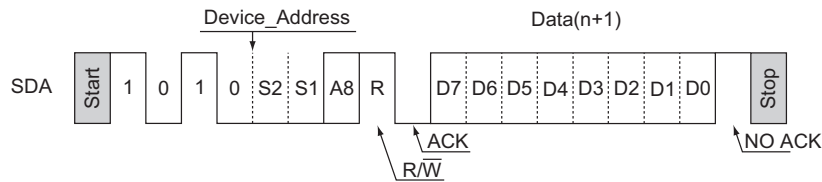

7-2. Random read

Random read is a mode in which any memory address is specified and its data read. The address is specified by a dummy write input.

First, when the EEPROM receives the 7-bit device address and write command code “0” following the start condition, it generates an acknowledge signal. It then receives the 8-bit word address, and generates an acknowledge signal. Through these operations, the word address is loaded into the address counter inside the EEPROM.

Next, the start condition is input again and the current read is initiated. This causes the data of the word address that was input using the dummy write input to be output. If, after the data is output, an acknowledge signal is not sent and the stop condition is input, reading is completed, and the EEPROM returns to standby mode.

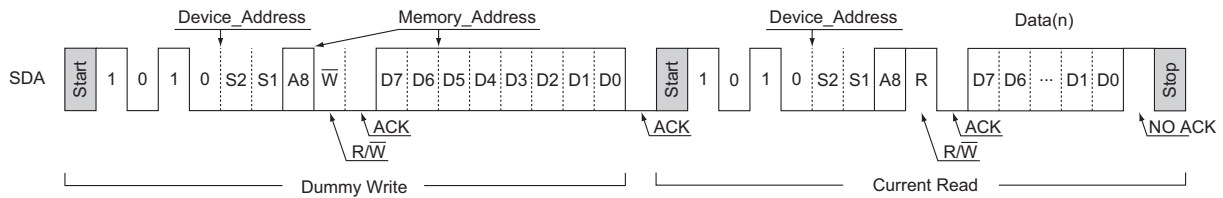

7-3. Sequential read

In this mode, the data is read continuously, and sequential read operations can be performed with both current address read and random read. If, after the 8-bit data has been output, acknowledge “0” is input and reading is continued without issuing the stop condition, the address is incremented, and the data of the next address is output.

If acknowledge “0” continues to be input after the data has been output in this way, the data is successively output while the address is incremented. When the last address is reached, it is rolled over to address 0, and the data continues to be read. As with current address read and random read, the operation is completed by inputting the stop condition without sending an acknowledge signal.

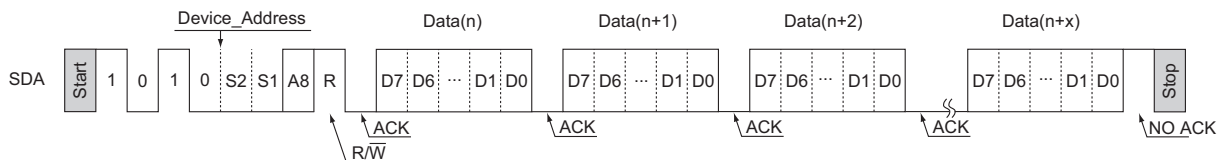

Application Notes

1) Software reset function

Software reset (start condition + 9 dummy clock cycles + start condition), shown in the figure below, is executed in order to avoid erroneous operation after power-on and to reset while the command input sequence. During the dummy clock input period, the SDA bus must be opened (set to high by a pull-up resistor). Since it is possible for the ACK output and read data to be output from the EEPROM during the dummy clock period, forcibly entering H will result in an overcurrent flow.

Note that this software reset function does not work during the internal write cycle.

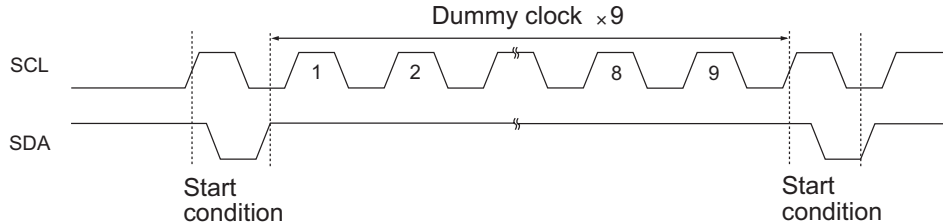

2) Pull-up resistor of SDA pin

Due to the demands of the I²C bus protocol function, the SDA pin must be connected to a pull-up resistor (with a resistance from several kΩ to several tens of kΩ) without fail. The appropriate value must be selected for this resistance (R_{PU}) on the basis of the V_{IL} and I_{IL} of the microcontroller and other devices controlling this product as well as the V_{OL}-I_{OL} characteristics of the product. Generally, when the resistance is too high, the operating frequency will be restricted; conversely, when it is too low, the operating current consumption will increase.

R_{PU} maximum resistance

The maximum resistance must be set in such a way that the bus potential, which is determined by the sum total (I_L) of the input leaks of the devices connected to the SDA bus and by R_{PU}, can completely satisfy the input high level (V_{IH min}) of the microcontroller and EEPROM. However, a resistance value that satisfies SDA rise time t_R and fall time t_F must be set.

$$R_{PU} \text{ maximum value} = (V_{DD} - V_{IH})/I_L$$

Example: When V_{DD}=2.5V and I_L= 2μA

$$R_{PU} \text{ maximum value} = (2.5V - 2.5V \times 0.8)/2\mu A = 250k\Omega$$

R_{PU} minimum value

A resistance corresponding to the low-level output voltage (V_{OL max}) of SANYO's EEPROM must be set.

$$R_{PU} \text{ minimum value} = (V_{DD} - V_{OL})/I_{OL}$$

Example: When V_{DD}=2.5V, V_{OL} = 0.4V and I_{OL} = 1mA

$$R_{PU} \text{ minimum value} = (2.5V - 0.4)/1mA = 2.1k\Omega$$

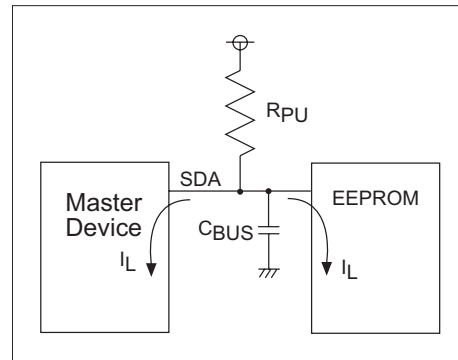

Recommended R_{PU} setting

R_{PU} is set to strike a good balance between the operating frequency requirements and power consumption. If it is assumed that the SDA load capacitance is 50pF and the SDA output data strobe time is 500ns, R_{PU} will be about R_{PU} = 500ns/50pF = 10kΩ.

LE24L042CS-B

3) Precautions when turning on the power

This product contains a power-on reset circuit for preventing the inadvertent writing of data when the power is turned on. The following conditions must be met in order to ensure stable operation of this circuit. No data guarantees are given in the event of an instantaneous power failure during the internal write operation.

Item	Symbol	V _{DD} =1.7 to 3.6V			unit
		min	typ	max	
Power rise time	t _{RISE}			100	ms
Power off time	t _{OFF}	10			ms
Power bottom voltage	V _{bot}			0.2	V

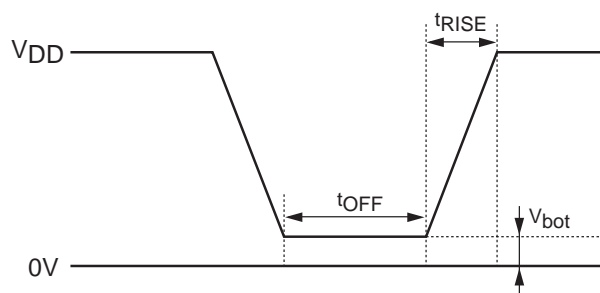

Notes:

- 1) The SDA pin must be set to high and the SCL pin to low or high.
- 2) Steps must be taken to ensure that the SDA and SCL pins are not placed in a high-impedance state.

A. If it is not possible to satisfy the instruction 1 in Note above, and SDA is set to low during power rise. After the power has stabilized, the SCL and SDA pins must be controlled as shown below, with both pins set to high.

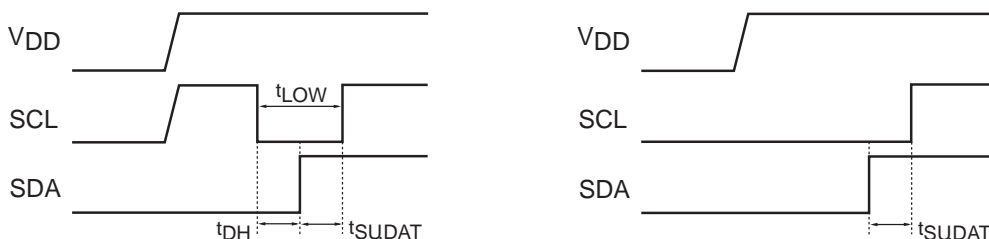

B. If it is not possible to satisfy the instruction 2 in Note above. After the power has stabilized, software reset must be executed.

C. If it is not possible to satisfy the instructions both 1 and 2 in Note above. After the power has stabilized, the steps in A must be executed, then software reset must be executed.

4) Noise filter for the SCL and SDA pins

This product contains a filter circuit for eliminating noise at the SCL and SDA pins. Pulses of 100ns or less are not recognized because of this function.

5) Function to inhibit writing when supply voltage is low

This product contains a supply voltage monitoring circuit that inhibits inadvertent writing below the guaranteed operating supply voltage range. The data is protected by ensuring that write operations are not started at voltages (typ.) of 1.3V and below.

6) Slave address settings

This product does not come with any slave address pins, but the information of the S0, S1 and S2 slave addresses is held internally. S1 = 0 and S2 = 0 were set for the slave addresses before shipment. During device addressing, these slave address codes must be executed following the device code.

- SANYO Semiconductor Co.,Ltd. assumes no responsibility for equipment failures that result from using products at values that exceed, even momentarily, rated values (such as maximum ratings, operating condition ranges, or other parameters) listed in products specifications of any and all SANYO Semiconductor Co.,Ltd. products described or contained herein.
- Regarding monolithic semiconductors, if you should intend to use this IC continuously under high temperature, high current, high voltage, or drastic temperature change, even if it is used within the range of absolute maximum ratings or operating conditions, there is a possibility of decrease reliability. Please contact us for a confirmation.
- SANYO Semiconductor Co.,Ltd. strives to supply high-quality high-reliability products, however, any and all semiconductor products fail or malfunction with some probability. It is possible that these probabilistic failures or malfunction could give rise to accidents or events that could endanger human lives, trouble that could give rise to smoke or fire, or accidents that could cause damage to other property. When designing equipment, adopt safety measures so that these kinds of accidents or events cannot occur. Such measures include but are not limited to protective circuits and error prevention circuits for safe design, redundant design, and structural design.
- In the event that any or all SANYO Semiconductor Co.,Ltd. products described or contained herein are controlled under any of applicable local export control laws and regulations, such products may require the export license from the authorities concerned in accordance with the above law.
- No part of this publication may be reproduced or transmitted in any form or by any means, electronic or mechanical, including photocopying and recording, or any information storage or retrieval system, or otherwise, without the prior written consent of SANYO Semiconductor Co.,Ltd.
- Any and all information described or contained herein are subject to change without notice due to product/technology improvement, etc. When designing equipment, refer to the "Delivery Specification" for the SANYO Semiconductor Co.,Ltd. product that you intend to use.
- Upon using the technical information or products described herein, neither warranty nor license shall be granted with regard to intellectual property rights or any other rights of SANYO Semiconductor Co.,Ltd. or any third party. SANYO Semiconductor Co.,Ltd. shall not be liable for any claim or suits with regard to a third party's intellectual property rights which has resulted from the use of the technical information and products mentioned above.

This catalog provides information as of Jun, 2012. Specifications and information herein are subject to change without notice.