

The TAH20 is a completely encapsulated thick film resistor in the TO220 package outline. Rated for 20 watts @ 25°C case temperature, these resistors are electrically isolated, and molded in a high temperature case.

Designed for heat sink mounting, the symmetrical package is ready for use with snap-on style heat sinks (we recommend use of thermal grease). The TAH20 Series is very low induction, and available in a wide range of resistance values in standard 5% tolerance. 1% tolerance available by special order.

FEATURES

- 20 Watt Power Rating at 25°C Case Temperature
- High Pulse Tolerant Design
- Quick-snap Molded Package
- Very Low Inductance Design
- Resistor Package Electrically Isolated from Heat Sink
- Low Thermal Resistance to Heat Sink @ $R_{\theta HC} < 6.25^\circ\text{C/W}$
- Tube Packaging Available

APPLICATIONS

- Frequency Conversion
- High Frequency Balancing
- Snubbers

SPECIFICATIONS

Electrical

Resistance Range: 0.05Ω to 10KΩ, other values available upon request

Tolerance: ±5% std.
1% Available on request

Temperature Coefficient:
Referenced to 25°C,
 ΔR taken at +105°C;
1 to 10Ω: ±(100ppm+0.002Ω)/°C
10Ω & up: ±50ppm/°C

Max Operating Voltage: 350V

Dielectric Strength: 1,800 VAC

Power Rating: 20W @ 25°C case temperature; see derating curve, next page

Insulation Resistance:
10GΩ min.

Momentary Overload:
2x rated power for 5 seconds where applied voltage ≤1.5 times max. operating voltage. ΔR ± (0.3% + 0.001Ω) max.

Terminal Material: Copper
Terminal Plating: Lead Free Solder (97% Tin, 3% Silver)

Mounting: Requires the use of a snap-on style heat sink. A thermal compound should be properly applied.

Solder Process: The TAH20 cannot exceed 260°C for more than 10 seconds during soldering process.



TAH20 Series

20 Watt TO220 Style Thick Film Power Resistors RoHS Compliant

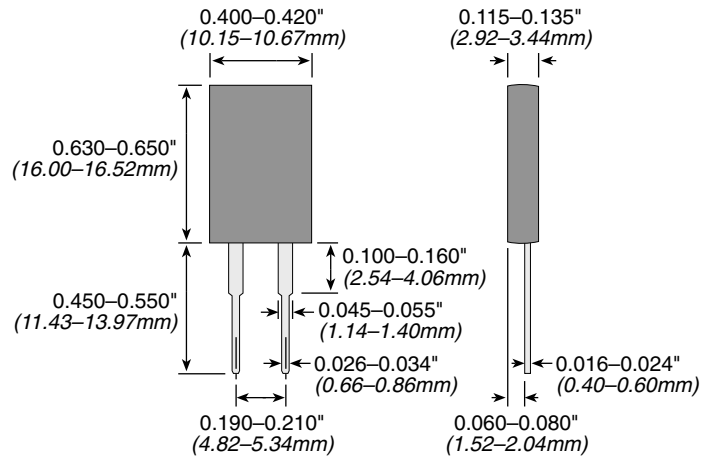

PERFORMANCE DATA

Load Life	MIL-R-39009, 2000 Hours @ Rated Pwr	$\Delta R = \pm(1.0\% + 0.001) \Omega$
Thermal Shock	MIL-R-STD-202, Method 107, Cond. F	$\Delta R = \pm(0.3\% + 0.001) \Omega$ max
High Freq Vibration	MIL-R-STD-202, Method 204, Cond. D	$\Delta R = \pm(0.2\% + 0.001) \Omega$ max
Terminal Strength	MIL-R-STD-202, Method 211, Cond. A (Pull Test) 2.4N	$\Delta R = \pm(0.2\% + 0.001) \Omega$ max
Moisture Resistance	MIL-R-STD-202, Method 106	$\Delta R = \pm(0.5\% + 0.01) \Omega$ max

(continued on next page)

Ohmite's new TCH35 TO220 package resistor provides 35W of steady state power when properly used in today's well defined heat sink applications.

These very low induction resistors are built under proprietary processes that deliver 75% more power handling capability than other TO220 package resistors of similar size.

Standard lead forms are provided for manual or automatic insertion.

A single screw mounting tab connects to the heat sink and should be accompanied by the use of a thermal compound. The TCH35 Series offers a low thermal resistance to the heat sink of 4.28°C/W.

FEATURES

- 35W Power Rating @ 25°C
- Very Low Inductance Design
- Single Screw Mounting
- Low Thermal Resistance to Heat Sink @ $R_{\theta HC} < 4.28^\circ\text{C/W}$
- Resistance Element is Electrically Insulated from Metal Heat Sink Mounting Tab

APPLICATIONS

- Switching Power Supplies
- Snubbers
- High Frequency
- Voltage Regulation
- Low Energy Pulse Loading

SPECIFICATIONS

Electrical

Resistance Range: 0.1Ω to 10KΩ (higher values on request subject to derating)

Resistance Tolerance:
± 5% standard
± 1% available on request

Temperature Coefficient:
Referenced to 25°C,
 ΔR taken at +105°C
10Ω and above: ±50 ppm/°C
1Ω to 10Ω:
±(100ppm + 0.002Ω)/°C

Max. Operating Voltage: 350V

Dielectric Strength: 1800 VAC

Insulation Resistance: 10GΩ min.

Momentary Overload: 2x rated power for 5 seconds as long as the applied voltage ≤1.5 times the continuous operating voltage, where $\Delta R \pm(0.3\% + 0.01\Omega)$ max

Terminal Material: Copper
Terminal Plating: Lead Free Solder (97% Tin, 3% Silver)

Maximum Torque: 0.9 Nm

Power Rating: 35 Watts @ 25°C case temperature; see derating curve, next page

Working Temperature Range:
-55°C to +175°C

Solder Process: The TCH35 cannot exceed 260°C for more than 10 seconds during soldering process.



TCH35 Series

35 Watt TO220 Style Thick Film Power Resistors RoHS Compliant

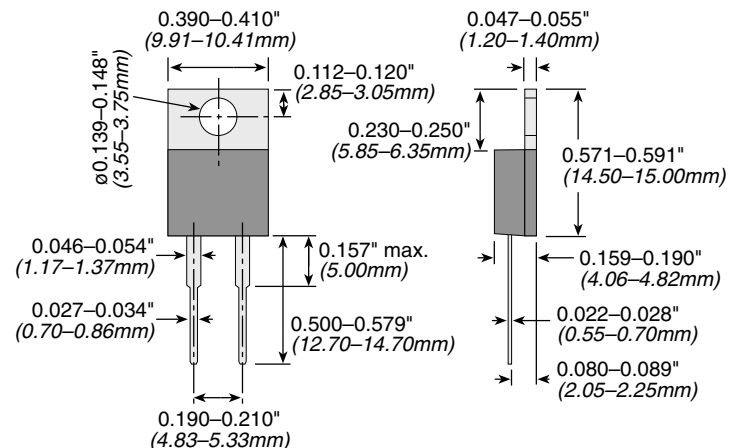

PERFORMANCE DATA

Load Life	MIL-R-39009, 2000 Hours @ Rated Pwr	$\Delta R = \pm(1.0\% + 0.01) \Omega$
Thermal Shock	MIL-R-STD-202, Method 107, Cond. F	$\Delta R = \pm(0.3\% + 0.01) \Omega$ max
High Freq Vibration	MIL-R-STD-202, Method 204, Cond. D	$\Delta R = \pm(0.2\% + 0.01) \Omega$ max
Terminal Strength	MIL-R-STD-202, Method 211, Cond. A (Pull Test) 2.4N	$\Delta R = \pm(0.2\% + 0.01) \Omega$ max
Moisture Resistance	MIL-R-STD-202, Method 106	$\Delta R = \pm(0.5\% + 0.01) \Omega$ max

(continued on next page)

TAH20/TCH35 Series

20 Watt & 35 Watt TO220 Series Thick Film Power Resistors (continued)

DERATING CURVE

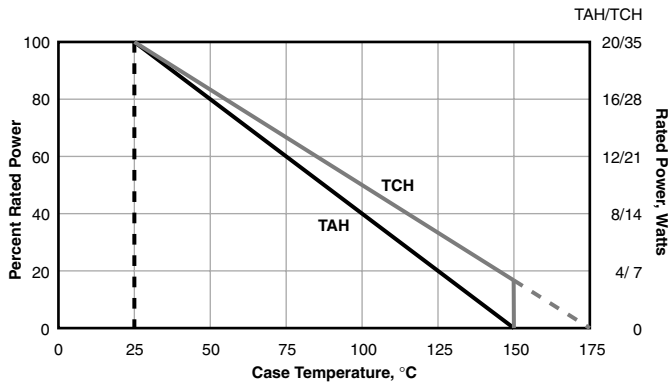

PULSE-FORM

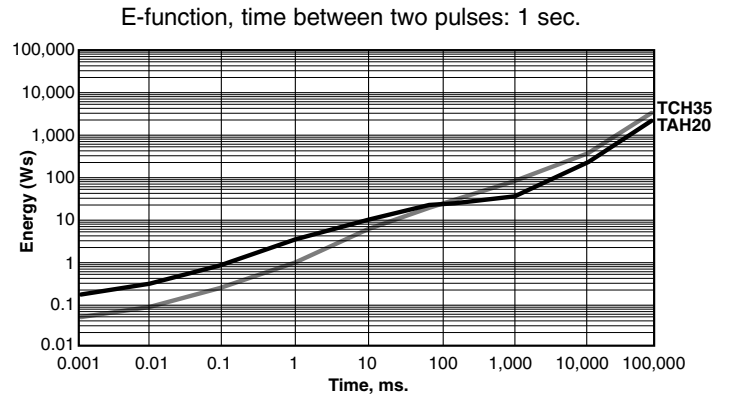

ORDERING INFORMATION

TCH35P10R0JE

Series
TCH35 = 35W
TAH20 = 20W

Ohm Value
Example:
2R40 = 2.4 Ohms
2K40 = 2400 Ohms

Package Code

Tolerance
F = 1%
J = 5% Standard

RoHS Compliant
Non-compliant
version not
recommended for
new designs

STANDARD VALUES

E24 standard values (+25 & 50), 1% and 5% tolerance

0.10	1.0	10	100	1,000	10,000
0.11	1.1	11	110	1,100	
0.12	1.2	12	120	1,200	
0.13	1.3	13	130	1,300	
0.15	1.5	15	150	1,500	
0.16	1.6	16	160	1,600	
0.18	1.8	18	180	1,800	
0.20	2.0	20	200	2,000	20,000
0.22	2.2	22	220	2,200	
0.24	2.4	24	240	2,400	
0.25	2.5	25	250	2,500	
0.27	2.7	27	270	2,700	
0.30	3.0	30	300	3,000	
0.33	3.3	33	330	3,300	
0.36	3.6	36	360	3,600	
0.39	3.9	39	390	3,900	
0.43	4.3	43	430	4,300	
0.47	4.7	47	470	4,700	
0.050	0.50	5.0	50	500	5,000
0.051	0.51	5.1	51	510	5,100
0.056	0.56	5.6	56	560	5,600
0.062	0.62	6.2	62	620	6,200
0.068	0.68	6.8	68	680	6,800
0.075	0.75	7.5	75	750	7,500
0.082	0.82	8.2	82	820	8,200
0.091	0.91	9.1	91	910	9,100

Consult factory for current stock disposition.