



# PCA9557

8-bit I<sup>2</sup>C-bus and SMBus I/O port with reset

Rev. 06 — 11 June 2008

Product data sheet

## 1. General description

The PCA9557 is a silicon CMOS circuit which provides parallel input/output expansion for SMBus and I<sup>2</sup>C-bus applications. The PCA9557 consists of an 8-bit input port register, 8-bit output port register, and an I<sup>2</sup>C-bus/SMBus interface. It has low current consumption and a high-impedance open-drain output pin, IO0.

The system master can enable the PCA9557's I/O as either input or output by writing to the configuration register. The system master can also invert the PCA9557 inputs by writing to the active HIGH polarity inversion register. Finally, the system master can reset the PCA9557 in the event of a time-out by asserting a LOW in the reset input.

The power-on reset puts the registers in their default state and initializes the I<sup>2</sup>C-bus/SMBus state machine. The  $\overline{\text{RESET}}$  pin causes the same reset/initialization to occur without de-powering the part.

## 2. Features

- Lower voltage, higher performance migration path for the PCA9556
- 8 general purpose input/output expander/collector
- Input/output configuration register
- Active HIGH polarity inversion register
- I<sup>2</sup>C-bus and SMBus interface logic
- Internal power-on reset
- Noise filter on SCL/SDA inputs
- Active LOW reset input
- 3 address pins allowing up to 8 devices on the I<sup>2</sup>C-bus/SMBus
- High-impedance open-drain on IO0
- No glitch on power-up
- Power-up with all channels configured as inputs
- Low standby current
- Operating power supply voltage range of 2.3 V to 5.5 V
- 5 V tolerant inputs/outputs
- 0 kHz to 400 kHz clock frequency
- ESD protection exceeds 2000 V HBM per JESD22-A114, 150 V MM per JESD22-A115 and 1000 V CDM per JESD22-C101
- Latch-up testing is done to JEDEC Standard JESD78 which exceeds 100 mA
- Three packages offered: SO16, TSSOP16, HVQFN16

### 3. Ordering information

Table 1. Ordering information

Type number	Package		Version
	Name	Description	
PCA9557D	SO16	plastic small outline package; 16 leads; body width 3.9 mm	SOT109-1
PCA9557PW	TSSOP16	plastic thin shrink small outline package; 16 leads; body width 4.4 mm	SOT403-1
PCA9557BS	HVQFN16	plastic thermal enhanced very thin quad flat package; no leads; 16 terminals; body 4 × 4 × 0.85 mm	SOT629-1

### 3.1 Ordering options

Table 2. Ordering options

Type number	Topside mark	Temperature range
PCA9557D	PCA9557D	T <sub>amb</sub> = -40 °C to +85 °C
PCA9557PW	PCA9557	T <sub>amb</sub> = -40 °C to +85 °C
PCA9557BS	9557	T <sub>amb</sub> = -40 °C to +85 °C

### 4. Block diagram

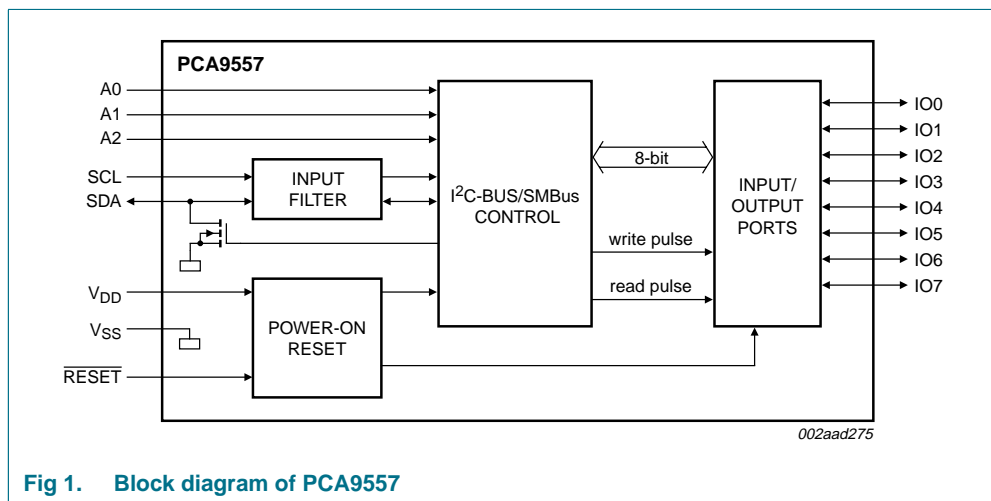
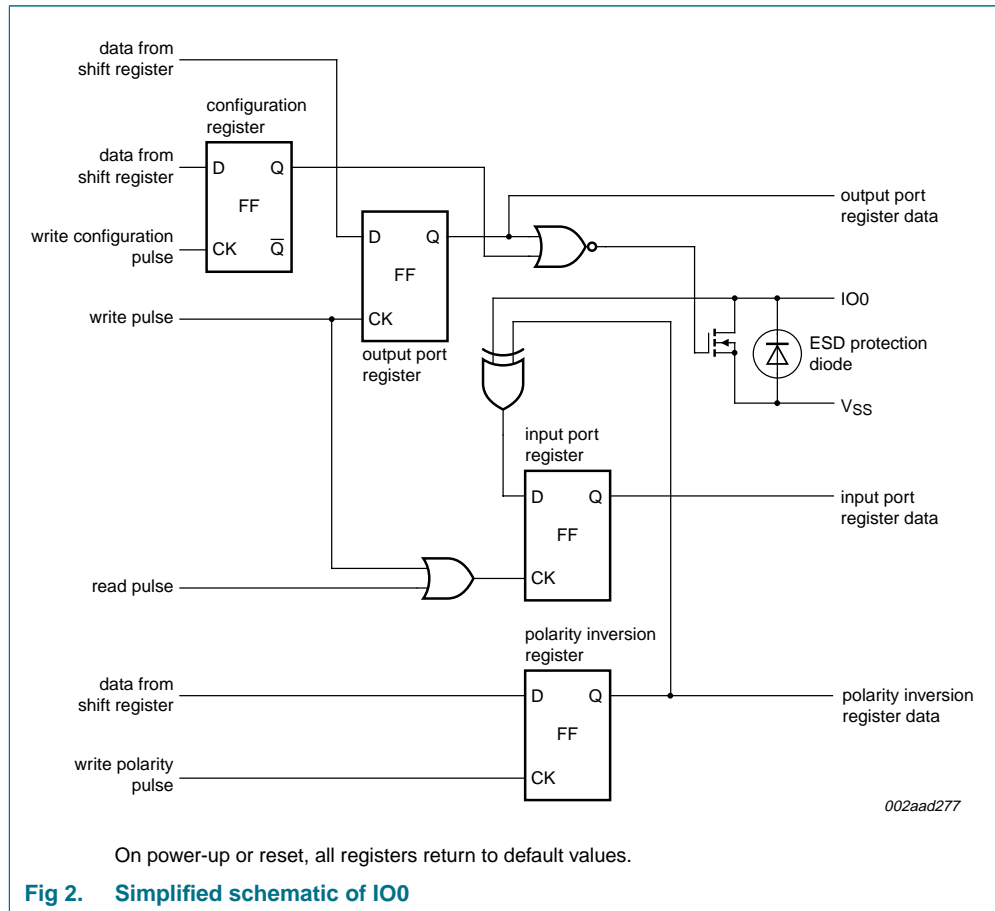

Fig 1. Block diagram of PCA9557





## 5. Pinning information

### 5.1 Pinning

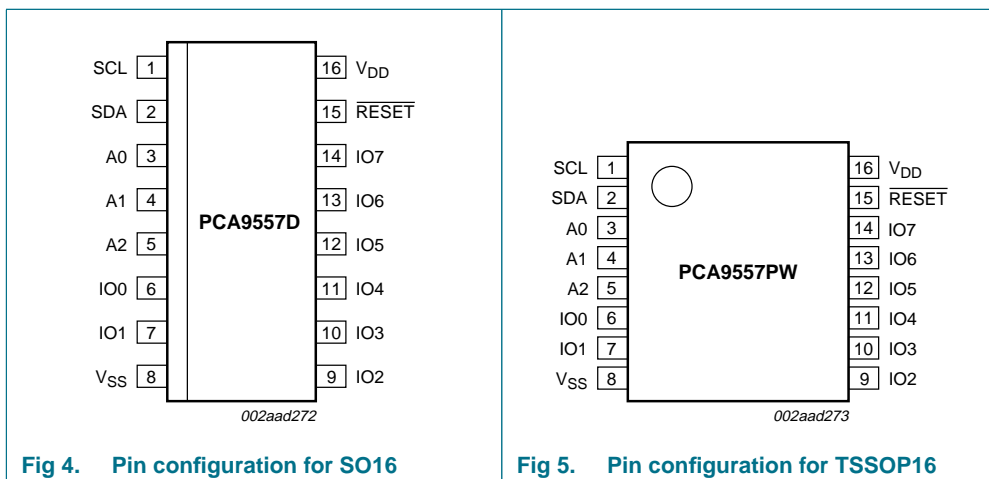

Fig 4. Pin configuration for SO16

Fig 5. Pin configuration for TSSOP16

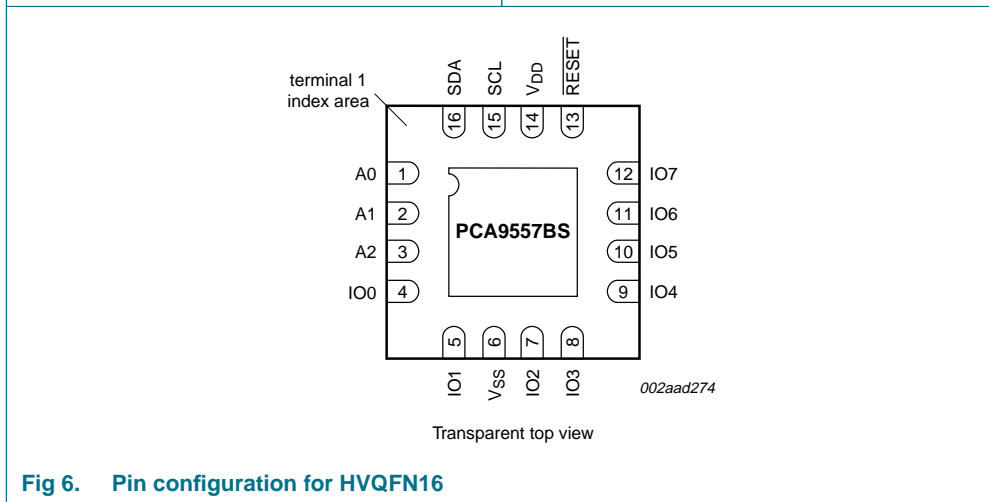

Fig 6. Pin configuration for HVQFN16

### 5.2 Pin description

Table 3. Pin description

Symbol	Pin		Description
	SO16, TSSOP16	HVQFN16	
SCL	1	15	serial clock line
SDA	2	16	serial data line
A0	3	1	address input 0
A1	4	2	address input 1
A2	5	3	address input 2
IO0	6	4	input/output 0 (open-drain)
IO1	7	5	input/output 1

Table 3. Pin description ...continued

Symbol	Pin		Description
	SO16, TSSOP16	HVQFN16	
V <sub>SS</sub>	8	6 <sup>[1]</sup>	supply ground
IO2	9	7	input/output 2
IO3	10	8	input/output 3
IO4	11	9	input/output 4
IO5	12	10	input/output 5
IO6	13	11	input/output 6
IO7	14	12	input/output 7
RESET	15	13	active LOW reset input
V <sub>DD</sub>	16	14	supply voltage

[1] HVQFN16 package die supply ground is connected to both the V<sub>SS</sub> pin and the exposed center pad. The V<sub>SS</sub> pin must be connected to the supply ground for proper device operation. For enhanced thermal, electrical, and board-level performance, the exposed pad needs to be soldered to the board using a corresponding thermal pad on the board, and for proper heat conduction through the board thermal vias need to be incorporated in the PCB in the thermal pad region.

## 6. System diagram

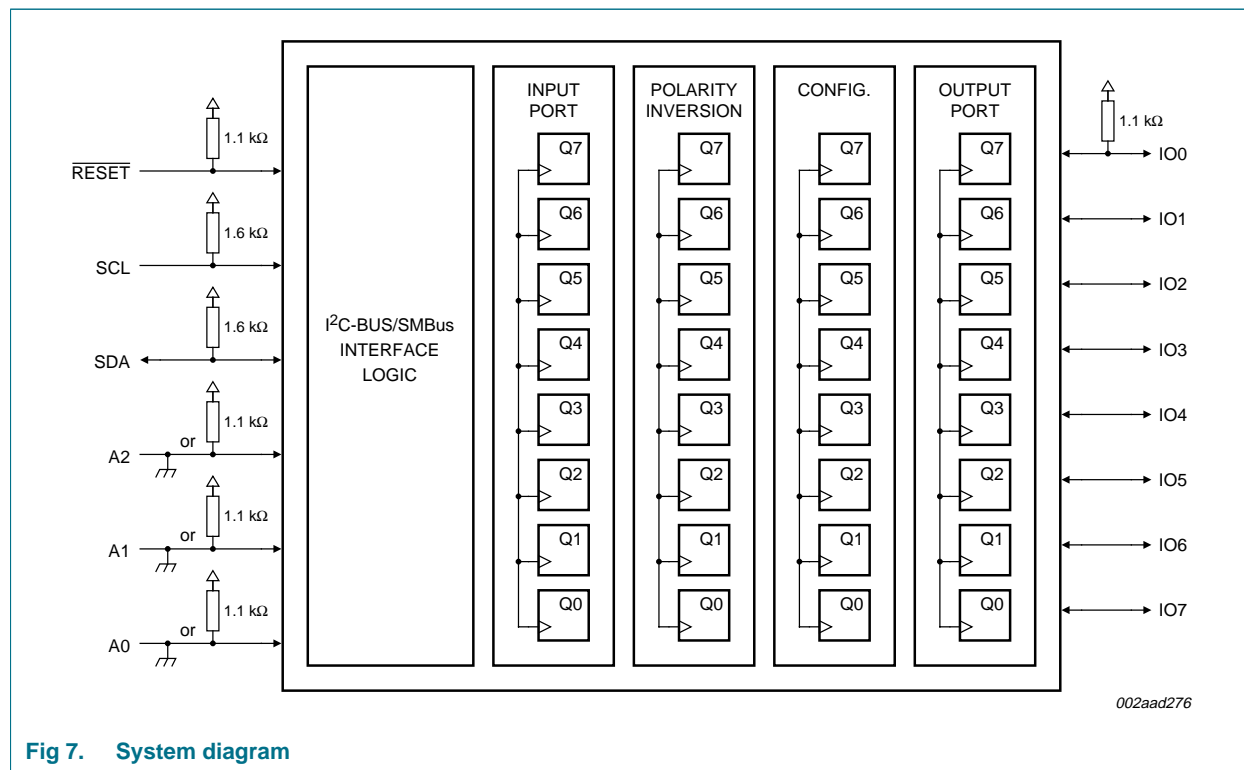

Fig 7. System diagram

## 7. Functional description

Refer to [Figure 1 “Block diagram of PCA9557”](#).

### 7.1 Device address

Following a START condition the bus master must output the address of the slave it is accessing. The address of the PCA9557 is shown in [Figure 8](#). To conserve power, no internal pull-up resistors are incorporated on the hardware selectable address pins and they must be pulled HIGH or LOW.

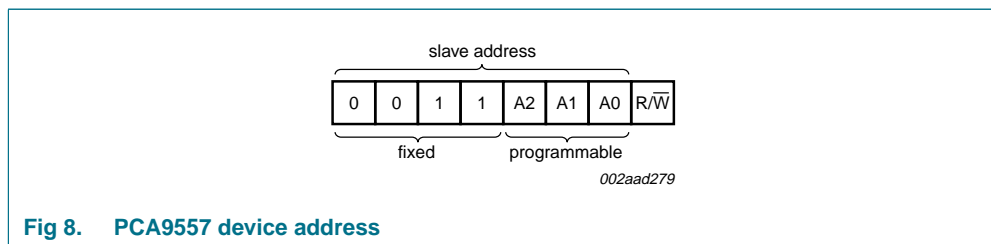
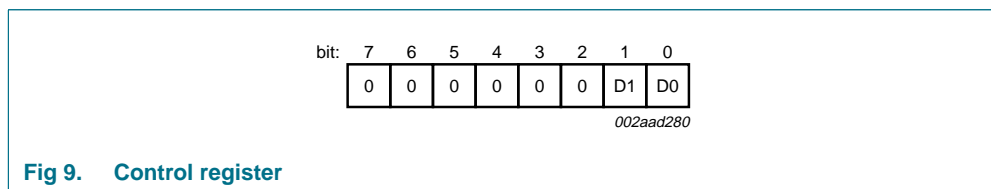

**Fig 8. PCA9557 device address**

The last bit of the slave address defines the operation to be performed. When set to logic 1 a read is selected, while a logic 0 selects a write operation.

### 7.2 Control register

Following the successful acknowledgement of the slave address, the bus master will send a byte to the PCA9557, which will be stored in the control register. This register can be written and read via the I<sup>2</sup>C-bus.



**Fig 9. Control register**

**Table 4. Register definition**

D1	D0	Name	Access	Description
0	0	Register 0	read-only	Input port register
0	1	Register 1	read/write	Output port register
1	0	Register 2	read/write	Polarity inversion register
1	1	Register 3	read/write	Configuration register

## 7.3 Register descriptions

### 7.3.1 Register 0 - Input port register

This register is a read-only port. It reflects the incoming logic levels of the pins, regardless of whether the pin is defined as an input or an output by the Configuration register. Writes to this register have no effect.

**Table 5. Register 0 - Input port register bit allocation**

Bit	7	6	5	4	3	2	1	0
Symbol	I7	I6	I5	I4	I3	I2	I1	I0

### 7.3.2 Register 1 - Output port register

This register reflects the outgoing logic levels of the pins defined as outputs by the Configuration register. Bit values in this register have no effect on pins defined as inputs. In turn, reads from this register reflect the value that is in the flip-flop controlling the output selection, **not** the actual pin value.

**Table 6. Register 1 - Output port register bit allocation**

Bit	7	6	5	4	3	2	1	0
Symbol	O7	O6	O5	O4	O3	O2	O1	O0
Default	0	0	0	0	0	0	0	0

### 7.3.3 Register 2 - Polarity inversion register

This register enables polarity inversion of pins defined as inputs by the Configuration register. If a bit in this register is set (written with logic 1), the corresponding port pin's polarity is inverted. If a bit in this register is cleared (written with logic 0), the corresponding port pin's original polarity is retained.

**Table 7. Register 2 - Polarity inversion register bit allocation**

Bit	7	6	5	4	3	2	1	0
Symbol	N7	N6	N5	N4	N3	N2	N1	N0
Default	1	1	1	1	0	0	0	0

### 7.3.4 Register 3 - Configuration register

This register configures the directions of the I/O pins. If a bit in this register is set, the corresponding port pin is enabled as an input with high-impedance output driver. If a bit in this register is cleared, the corresponding port pin is enabled as an output.

**Table 8. Register 3 - Configuration register bit allocation**

Bit	7	6	5	4	3	2	1	0
Symbol	C7	C6	C5	C4	C3	C2	C1	C0
Default	1	1	1	1	1	1	1	1



## 7.4 Power-on reset

When power is applied to  $V_{DD}$ , an internal Power-On Reset (POR) holds the PCA9557 in a reset condition until  $V_{DD}$  has reached  $V_{POR}$ . At that point, the reset condition is released and the PCA9557 registers and I<sup>2</sup>C-bus/SMBus state machine will initialize to their default states. Thereafter,  $V_{DD}$  must be lowered below 0.2 V to reset the device.

## 7.5 $\overline{\text{RESET}}$ input

A reset can be accomplished by holding the  $\overline{\text{RESET}}$  pin LOW for a minimum of  $t_{w(\text{rst})}$ . The PCA9557 registers and SMBus/I<sup>2</sup>C-bus state machine will be held in their default state until the  $\overline{\text{RESET}}$  input is once again HIGH. This input requires a pull-up resistor to  $V_{DD}$  if no active connection is used.

# 8. Characteristics of the I<sup>2</sup>C-bus

The I<sup>2</sup>C-bus is for 2-way, 2-line communication between different ICs or modules. The two lines are a serial data line (SDA) and a serial clock line (SCL). Both lines must be connected to a positive supply via a pull-up resistor when connected to the output stages of a device. Data transfer may be initiated only when the bus is not busy.

## 8.1 Bit transfer

One data bit is transferred during each clock pulse. The data on the SDA line must remain stable during the HIGH period of the clock pulse as changes in the data line at this time will be interpreted as control signals (see [Figure 10](#)).

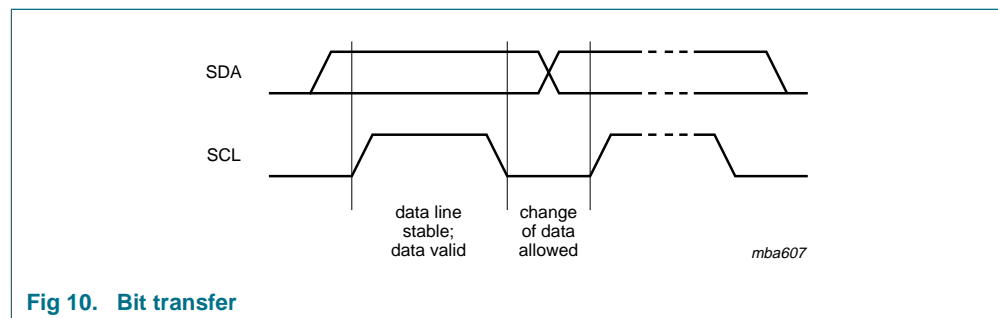

Fig 10. Bit transfer

### 8.1.1 START and STOP conditions

Both data and clock lines remain HIGH when the bus is not busy. A HIGH-to-LOW transition of the data line while the clock is HIGH is defined as the START condition (S). A LOW-to-HIGH transition of the data line while the clock is HIGH is defined as the STOP condition (P) (see [Figure 11](#)).

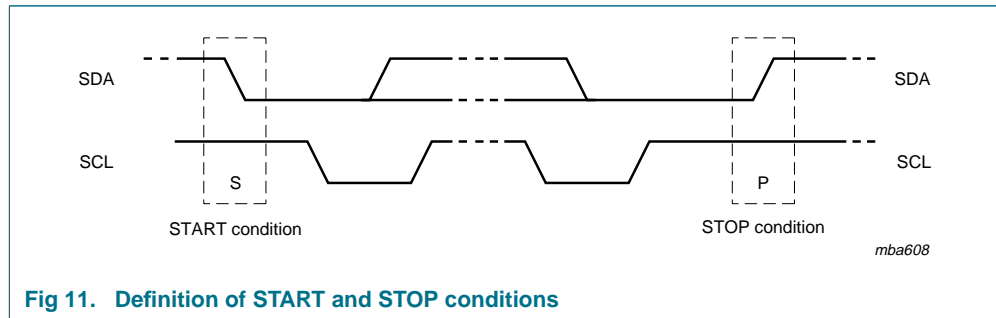

Fig 11. Definition of START and STOP conditions

## 8.2 System configuration

A device generating a message is a 'transmitter'; a device receiving is the 'receiver'. The device that controls the message is the 'master' and the devices which are controlled by the master are the 'slaves' (see [Figure 12](#)).

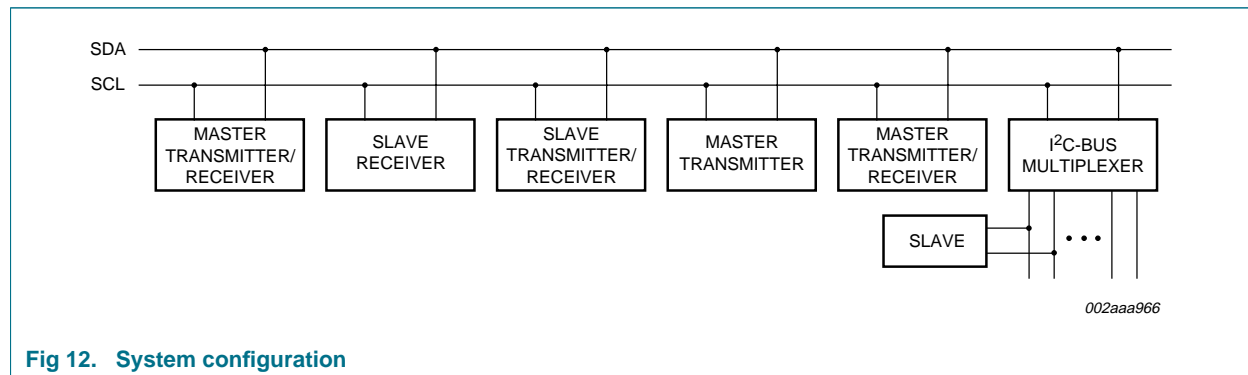

Fig 12. System configuration

## 8.3 Acknowledge

The number of data bytes transferred between the START and the STOP conditions from transmitter to receiver is not limited. Each byte of eight bits is followed by one acknowledge bit. The acknowledge bit is a HIGH level put on the bus by the transmitter, whereas the master generates an extra acknowledge related clock pulse.

A slave receiver which is addressed must generate an acknowledge after the reception of each byte. Also a master must generate an acknowledge after the reception of each byte that has been clocked out of the slave transmitter. The device that acknowledges has to pull down the SDA line during the acknowledge clock pulse, so that the SDA line is stable LOW during the HIGH period of the acknowledge related clock pulse; set-up and hold times must be taken into account.

A master receiver must signal an end of data to the transmitter by not generating an acknowledge on the last byte that has been clocked out of the slave. In this event, the transmitter must leave the data line HIGH to enable the master to generate a STOP condition.

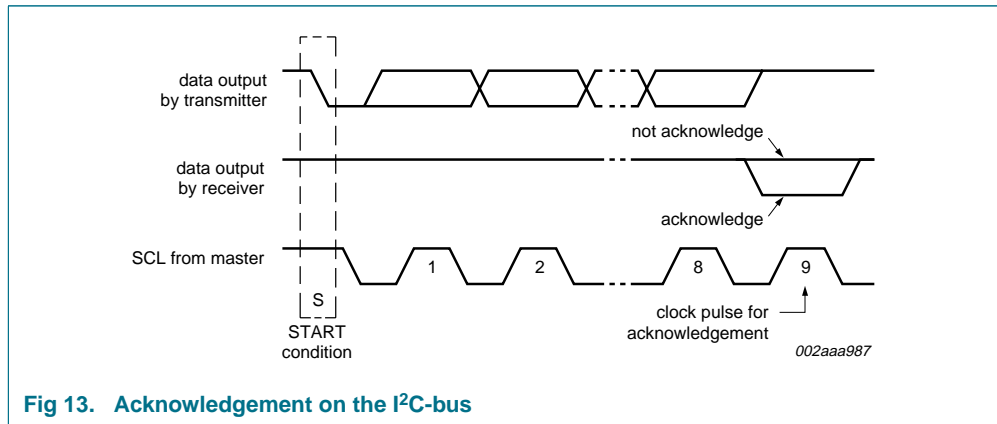

Fig 13. Acknowledgement on the I<sup>2</sup>C-bus

### 8.4 Bus transactions

Data is transmitted to the PCA9557 registers using Write Byte transfers (see [Figure 14](#) and [Figure 15](#)). Data is read from the PCA9557 registers using Read and Receive Byte transfers (see [Figure 16](#) and [Figure 17](#)).

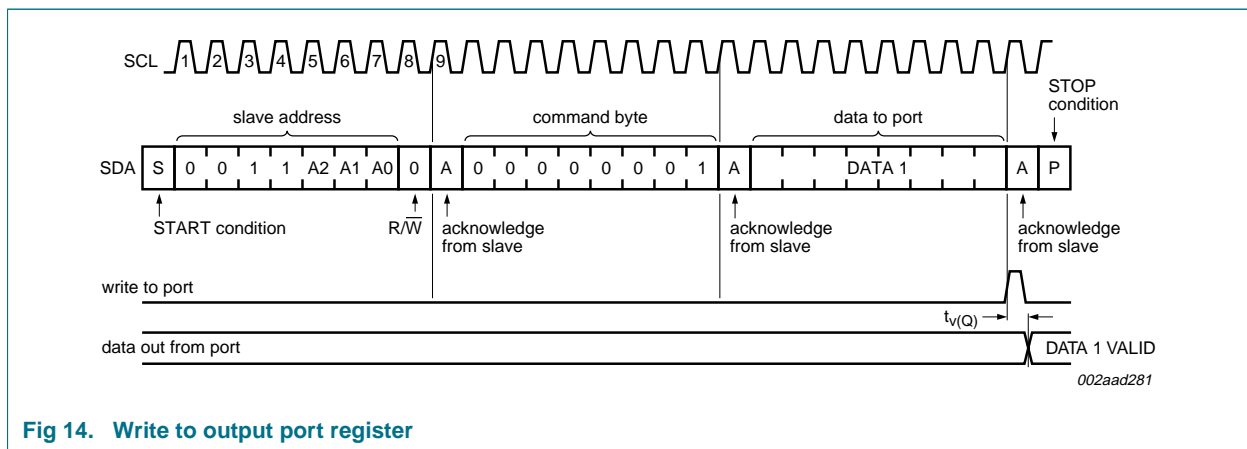

Fig 14. Write to output port register

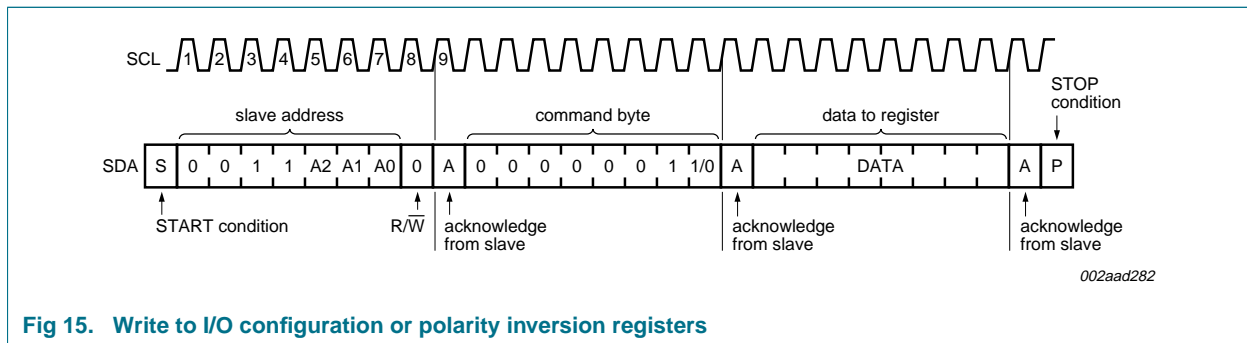
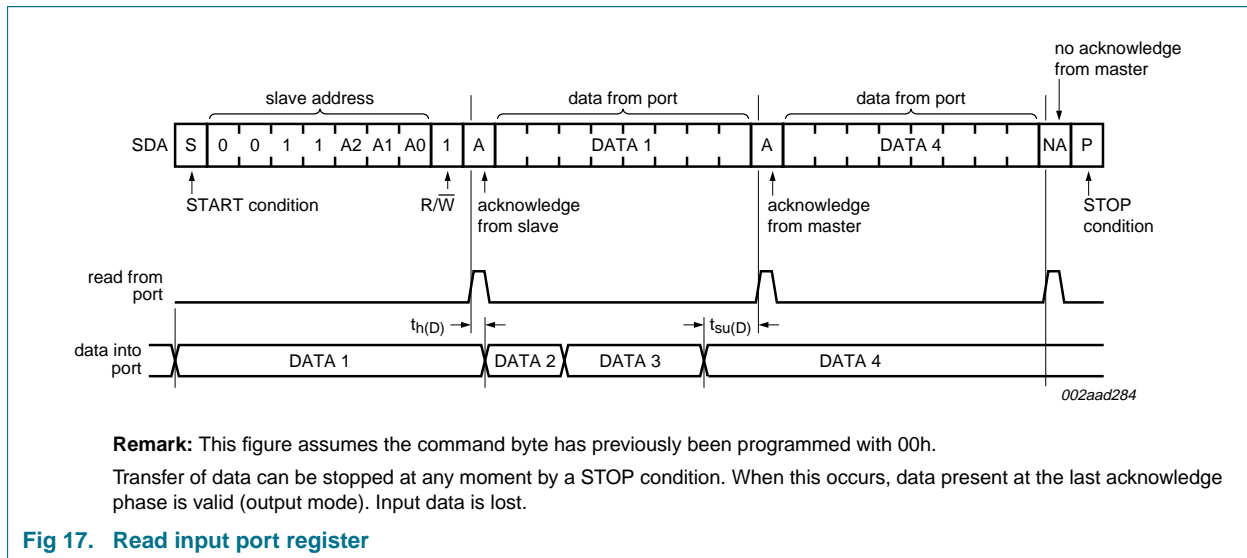
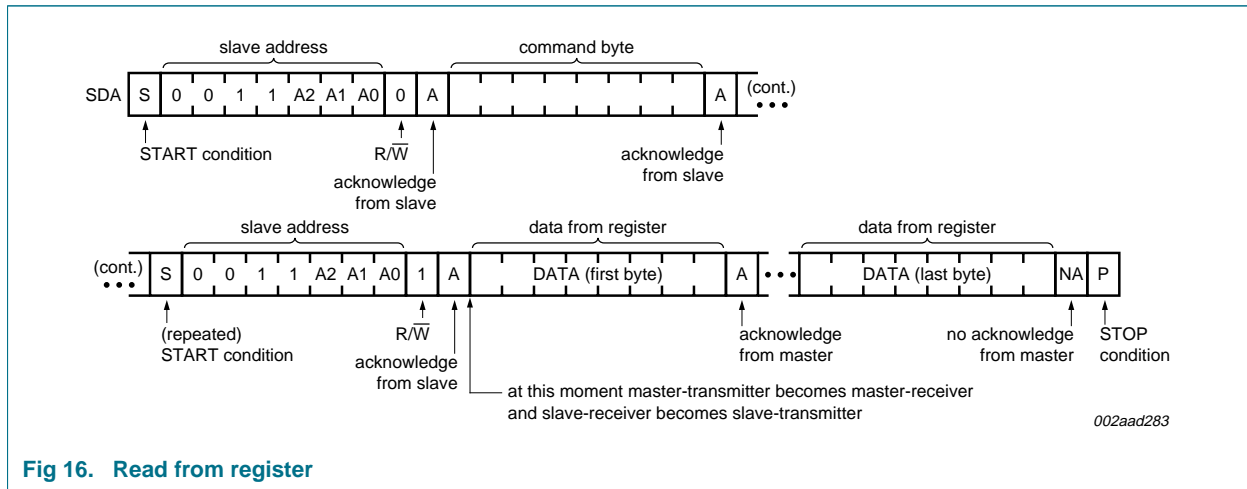

Fig 15. Write to I/O configuration or polarity inversion registers



## 9. Application design-in information

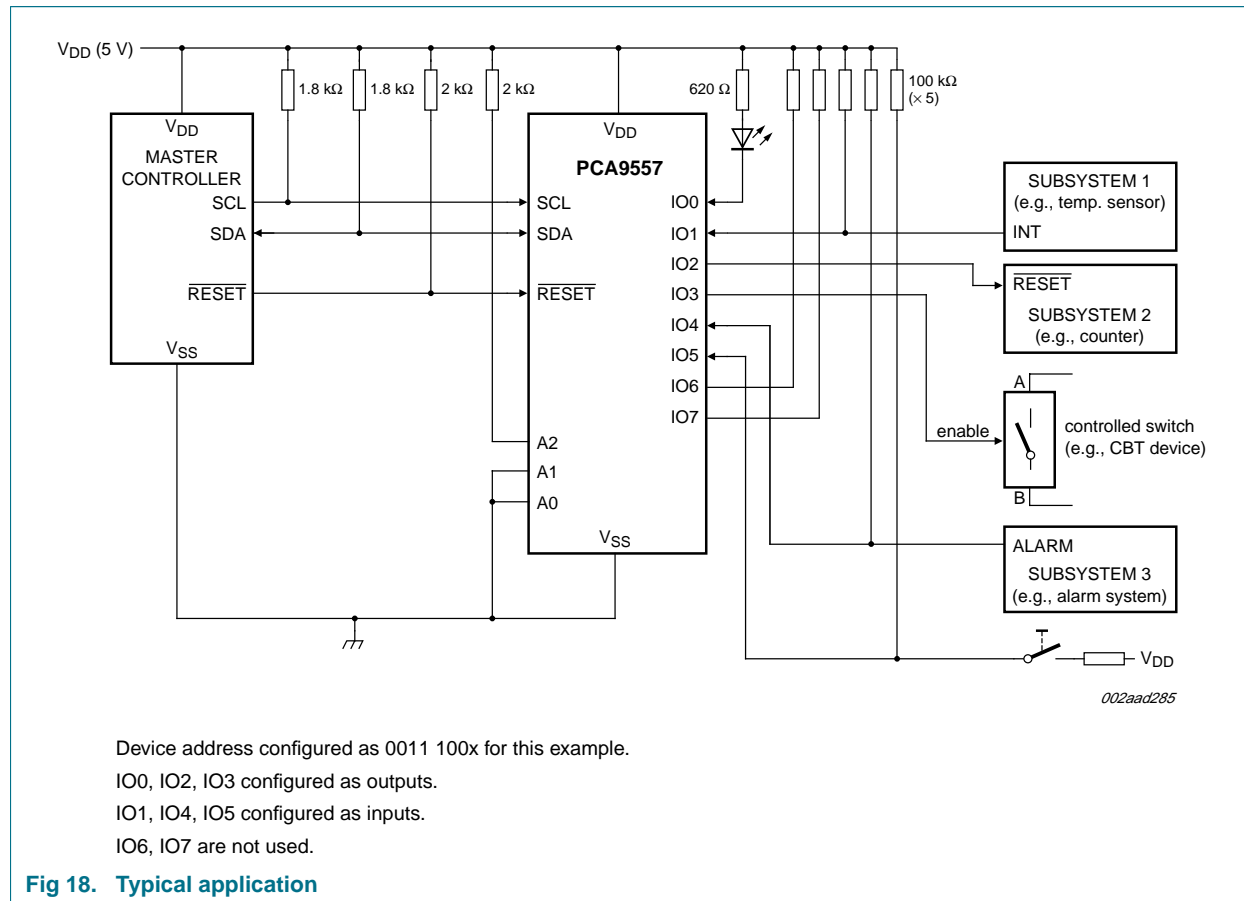
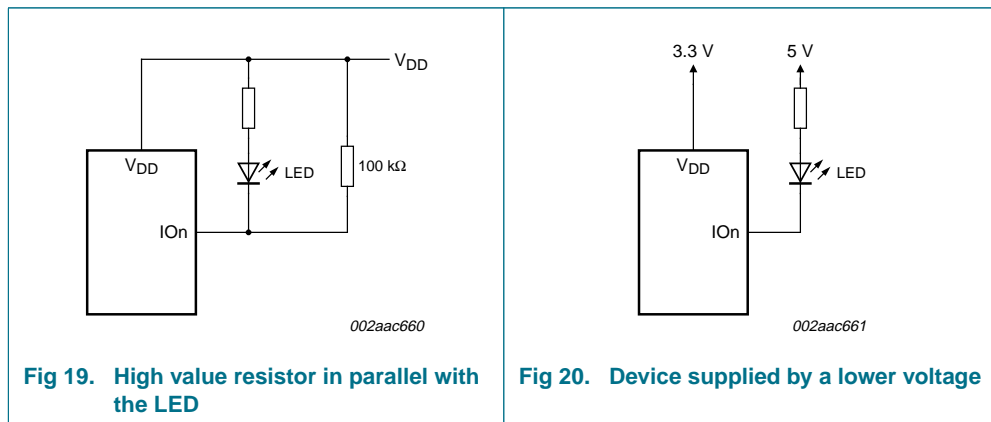

Fig 18. Typical application

### 9.1 Minimizing I<sub>DD</sub> when the I/Os are used to control LEDs

When the I/Os are used to control LEDs, they are normally connected to V<sub>DD</sub> through a resistor as shown in Figure 18. Since the LED acts as a diode, when the LED is off the I/O V<sub>I</sub> is about 1.2 V less than V<sub>DD</sub>. The supply current, I<sub>DD</sub>, increases as V<sub>I</sub> becomes lower than V<sub>DD</sub>.

Designs needing to minimize current consumption, such as battery power applications, should consider maintaining the I/O pins greater than or equal to V<sub>DD</sub> when the LED is off. Figure 19 shows a high value resistor in parallel with the LED. Figure 20 shows V<sub>DD</sub> less than the LED supply voltage by at least 1.2 V. Both of these methods maintain the I/O V<sub>I</sub> at or above V<sub>DD</sub> and prevents additional supply current consumption when the LED is off.



## 10. Limiting values

**Table 9. Limiting values**

In accordance with the Absolute Maximum Rating System (IEC 60134).

Symbol	Parameter	Conditions	Min	Max	Unit
V <sub>DD</sub>	supply voltage		-0.5	+6	V
V <sub>I</sub>	input voltage		V <sub>SS</sub> - 0.5	5.5	V
I <sub>I</sub>	input current		-	±20	mA
I <sub>IHL(max)</sub>	maximum allowed input current through protection diode (IO1 to IO7)	V <sub>I</sub> ≥ V <sub>DD</sub> or V <sub>I</sub> ≤ V <sub>SS</sub>	-	±400	µA
V <sub>I/O</sub>	voltage on an input/output pin	I/O as an input, except IO0	V <sub>SS</sub> - 0.5	5.5	V
		IO0 as an input	V <sub>SS</sub> - 0.5	5.5	V
I <sub>I/O</sub>	input/output current	IO0 as an input	-	+400	µA
			-	-20	mA
I <sub>O(IO<sub>n</sub>)</sub>	output current on pin IO <sub>n</sub>		-	±50	mA
I <sub>DD</sub>	supply current		-	85	mA
I <sub>SS</sub>	ground supply current		-	100	mA
P <sub>tot</sub>	total power dissipation		-	200	mW
T <sub>stg</sub>	storage temperature		-65	+150	°C
T <sub>amb</sub>	ambient temperature	operating	-40	+85	°C

## 11. Static characteristics

**Table 10. Static characteristics**
 $V_{DD} = 2.3\text{ V to }5.5\text{ V}$ ;  $V_{SS} = 0\text{ V}$ ;  $T_{amb} = -40\text{ }^{\circ}\text{C to }+85\text{ }^{\circ}\text{C}$ ; unless otherwise specified.

Symbol	Parameter	Conditions	Min	Typ	Max	Unit
<b>Supplies</b>						
$V_{DD}$	supply voltage		2.3	-	5.5	V
$I_{DD}$	supply current	operating mode; $V_{DD} = 5.5\text{ V}$ ; no load; $f_{SCL} = 100\text{ kHz}$	-	19	25	$\mu\text{A}$
$I_{stbL}$	LOW-level standby current	standby mode; $V_{DD} = 5.5\text{ V}$ ; no load; $V_I = V_{SS}$ ; $f_{SCL} = 0\text{ kHz}$ ; I/O = inputs	-	0.25	1	$\mu\text{A}$
$I_{stbH}$	HIGH-level standby current	standby mode; $V_{DD} = 5.5\text{ V}$ ; no load; $V_I = V_{DD}$ ; $f_{SCL} = 0\text{ kHz}$ ; I/O = inputs	-	0.25	1	$\mu\text{A}$
$\Delta I_{stb}$	additional standby current	standby mode; $V_{DD} = 5.5\text{ V}$ ; every LED I/O at $V_I = 4.3\text{ V}$ ; $f_{SCL} = 0\text{ kHz}$	-	0.8	1	mA
$V_{POR}$	power-on reset voltage	no load; $V_I = V_{DD}$ or $V_{SS}$	[1] -	1.65	2.1	V
<b>Input SCL; input/output SDA</b>						
$V_{IL}$	LOW-level input voltage		-0.5	-	+0.3 $V_{DD}$	V
$V_{IH}$	HIGH-level input voltage		0.7 $V_{DD}$	-	5.5	V
$I_{OL}$	LOW-level output current	$V_{OL} = 0.4\text{ V}$	3	-	-	mA
$I_L$	leakage current	$V_I = V_{DD}$ or $V_{SS}$	-1	-	+1	$\mu\text{A}$
$C_i$	input capacitance	$V_I = V_{SS}$	-	6	10	pF
<b>I/Os</b>						
$V_{IL}$	LOW-level input voltage		-0.5	-	+0.8	V
$V_{IH}$	HIGH-level input voltage		2.0	-	5.5	V
$I_{OL}$	LOW-level output current		[2] 8	10	-	mA
$I_{OH}$	HIGH-level output current	except pin IO0; $V_{OH} = 2.4\text{ V}$	[3] 4	-	-	mA
		pin IO0; $V_{OH} = 4.6\text{ V}$	-	-	1	$\mu\text{A}$
		pin IO0; $V_{OH} = 3.3\text{ V}$	-	-	1	$\mu\text{A}$
$I_{LI}$	input leakage current	$V_{DD} = 5.5\text{ V}$ ; $V_I = V_{SS}$	-	-	-100	$\mu\text{A}$
$C_i$	input capacitance		-	3.7	5	pF
$C_o$	output capacitance		-	3.7	5	pF
<b>Select inputs A0, A1, A2 and RESET</b>						
$V_{IL}$	LOW-level input voltage		-0.5	-	+0.8	V
$V_{IH}$	HIGH-level input voltage		2.0	-	5.5	V
$I_{LI}$	input leakage current		-1	-	+1	$\mu\text{A}$

[1]  $V_{DD}$  must be lowered to 0.2 V in order to reset part.

[2] The total amount sunk by all I/Os must be limited to 100 mA and 25 mA per bit.

[3] The total current sourced by all I/Os must be limited to 85 mA and 20 mA per bit.

## 12. Dynamic characteristics

Table 11. Dynamic characteristics

Symbol	Parameter	Conditions	Standard-mode I <sup>2</sup> C-bus		Fast-mode I <sup>2</sup> C-bus		Unit
			Min	Max	Min	Max	
f <sub>SCL</sub>	SCL clock frequency		0	100	0	400	kHz
t <sub>BUF</sub>	bus free time between a STOP and START condition		4.7	-	1.3	-	μs
t <sub>HD;STA</sub>	hold time (repeated) START condition		4.0	-	0.6	-	μs
t <sub>SU;STA</sub>	set-up time for a repeated START condition		4.7	-	0.6	-	μs
t <sub>SU;STO</sub>	set-up time for STOP condition		4.0	-	0.6	-	μs
t <sub>HD;DAT</sub>	data hold time		0	-	0	-	ns
t <sub>VD;ACK</sub>	data valid acknowledge time	[1]	-	1	-	0.9	μs
t <sub>VD;DAT</sub>	data valid time	[2]	-	1	-	0.9	ms
t <sub>SU;DAT</sub>	data set-up time		250	-	100	-	ns
t <sub>LOW</sub>	LOW period of the SCL clock		4.7	-	1.3	-	μs
t <sub>HIGH</sub>	HIGH period of the SCL clock		4.0	-	0.6	-	μs
t <sub>f</sub>	fall time of both SDA and SCL signals		-	300	20 + 0.1C <sub>b</sub> [3]	300	ns
t <sub>r</sub>	rise time of both SDA and SCL signals		-	1000	20 + 0.1C <sub>b</sub> [3]	300	ns
t <sub>SP</sub>	pulse width of spikes that must be suppressed by the input filter		-	50	-	50	ns
<b>Port timing</b>							
t <sub>v(Q)</sub>	data output valid time	pin IO0	-	250	-	250	ns
		pins IO1 to IO7	-	200	-	200	ns
t <sub>su(D)</sub>	data input set-up time		0	-	0	-	ns
t <sub>h(D)</sub>	data input hold time		200	-	200	-	ns
<b>Reset timing</b>							
t <sub>w(rst)</sub>	reset pulse width		6	-	6	-	ns
t <sub>rec(rst)</sub>	reset recovery time		0	-	0	-	ns
t <sub>rst</sub>	reset time		400	-	400	-	ns

[1] t<sub>VD;ACK</sub> = time for acknowledgement signal from SCL LOW to SDA (out) LOW.

[2] t<sub>VD;DAT</sub> = minimum time for SDA data out to be valid following SCL LOW.

[3] C<sub>b</sub> = total capacitance of one bus line in pF.



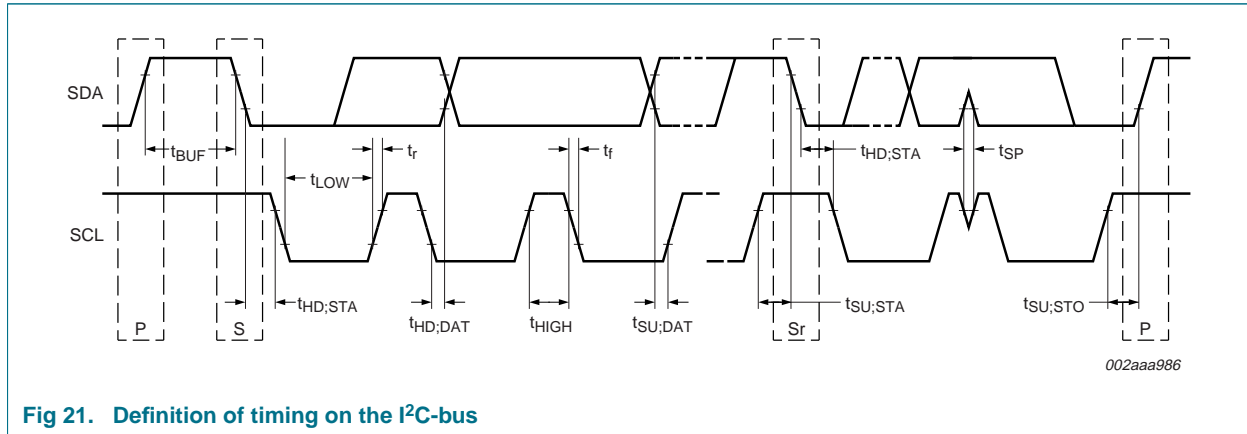

Fig 21. Definition of timing on the I<sup>2</sup>C-bus

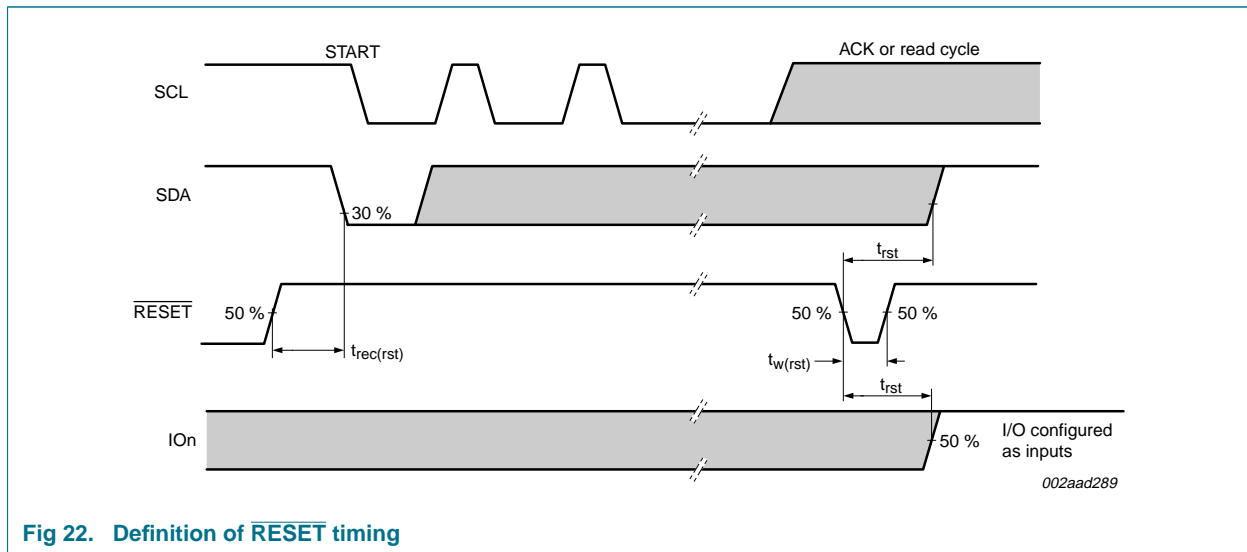

Fig 22. Definition of RESET timing

### 13. Package outline

SO16: plastic small outline package; 16 leads; body width 3.9 mm

SOT109-1

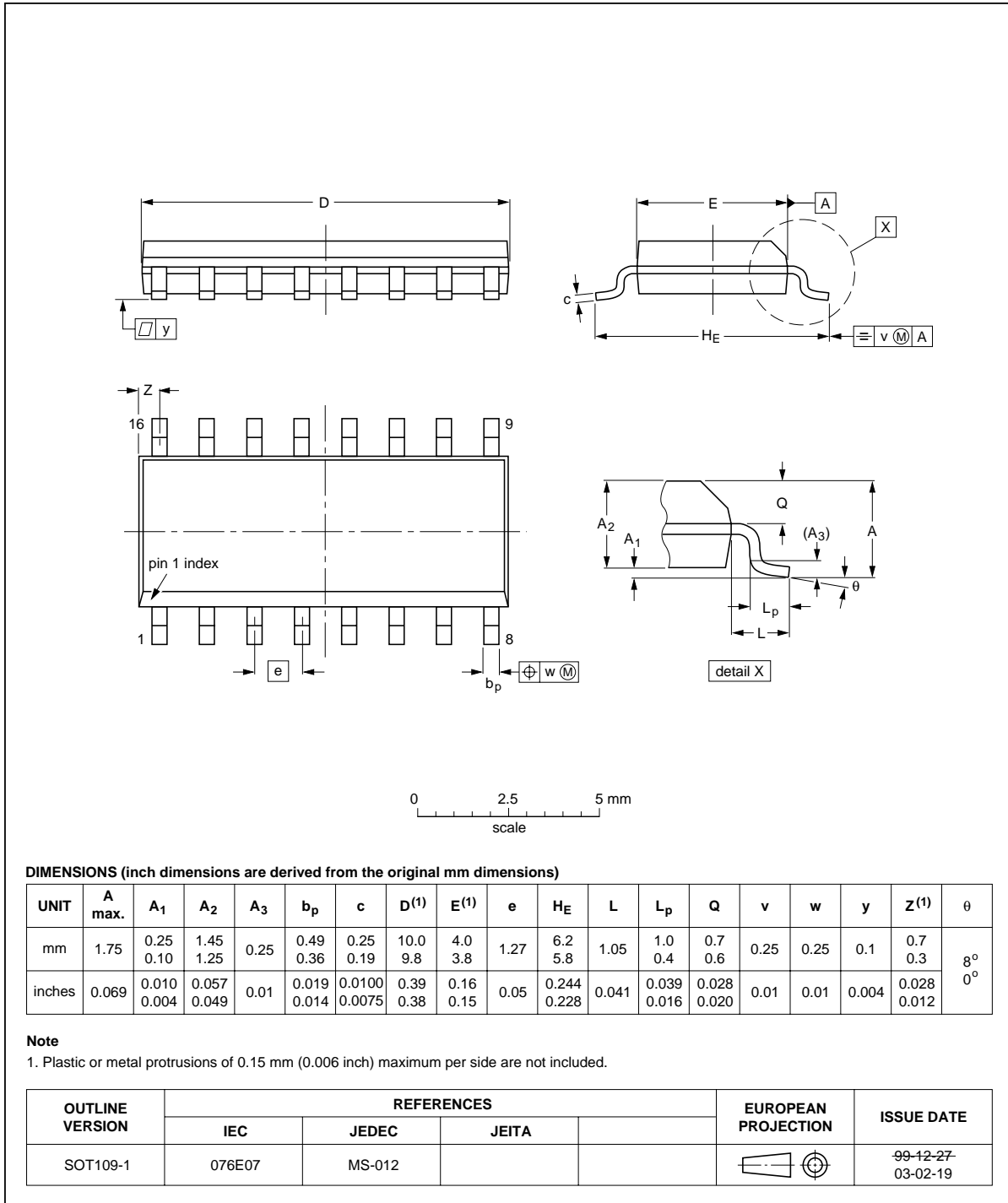

Fig 23. Package outline SOT109-1 (SO16)

TSSOP16: plastic thin shrink small outline package; 16 leads; body width 4.4 mm

SOT403-1

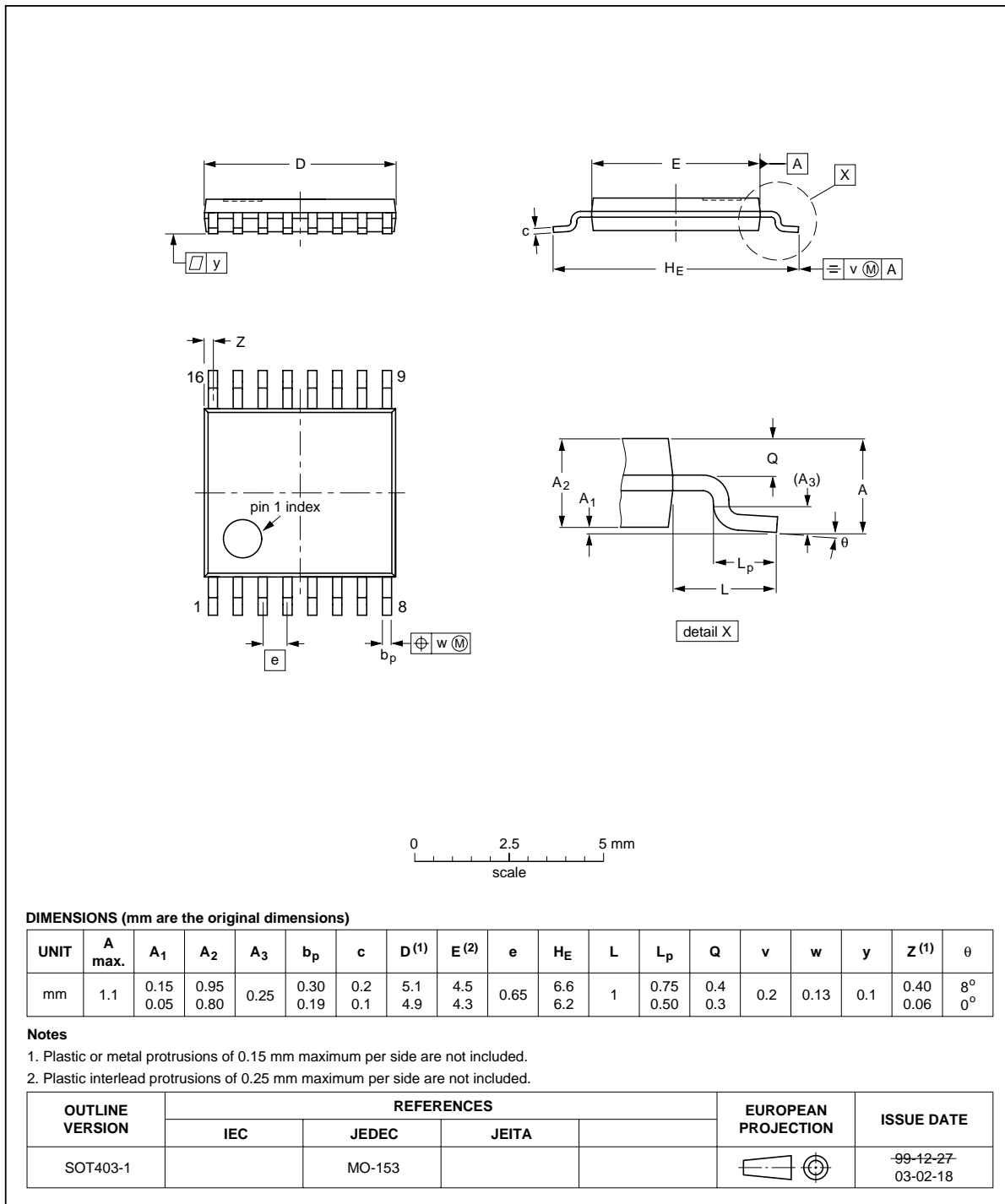

Fig 24. Package outline SOT403-1 (TSSOP16)

HVQFN16: plastic thermal enhanced very thin quad flat package; no leads;  
16 terminals; body 4 x 4 x 0.85 mm

SOT629-1

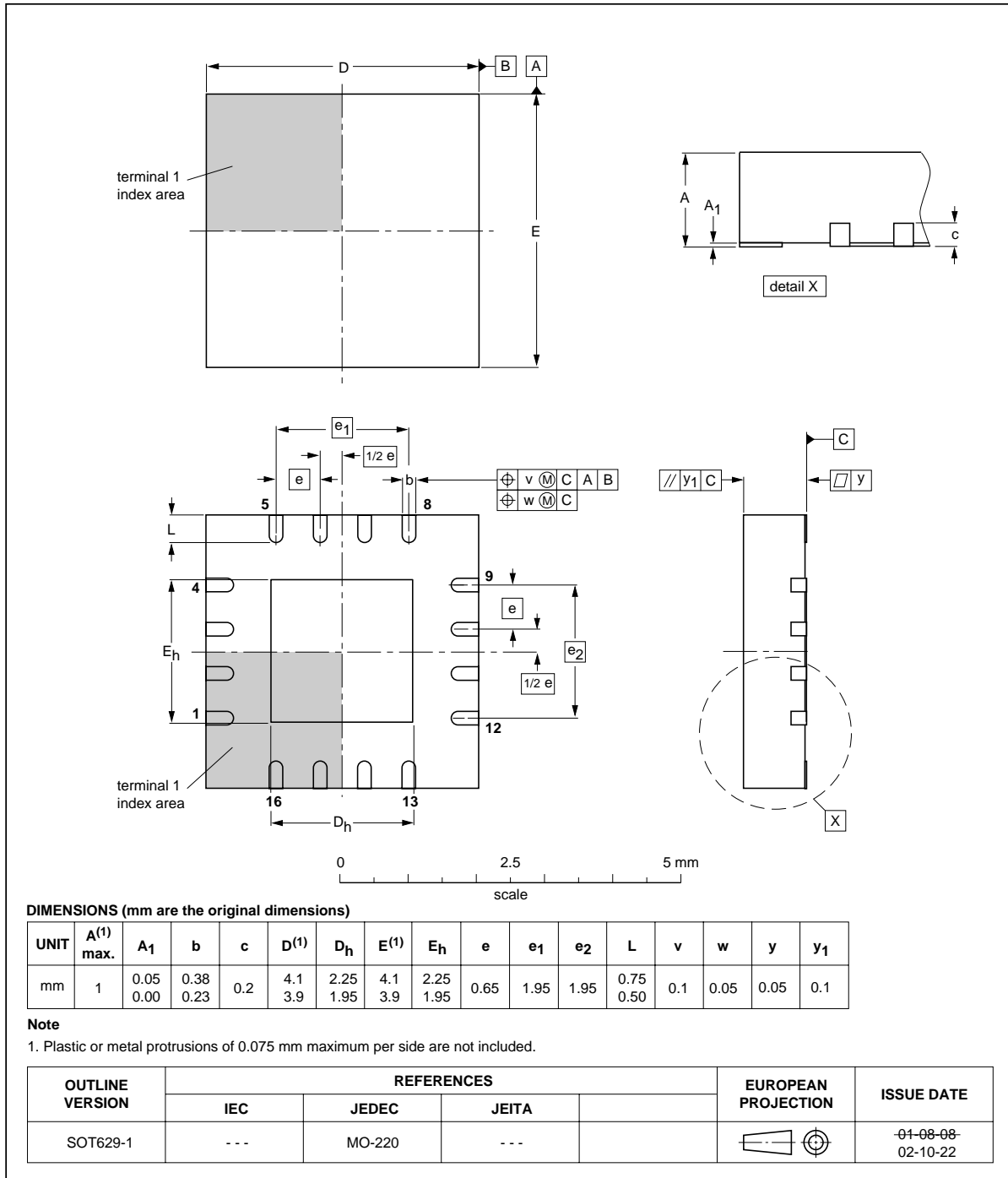

Fig 25. Package outline SOT629-1 (HVQFN16)

## 14. Handling information

---

Inputs and outputs are protected against electrostatic discharge in normal handling. However, to be completely safe you must take normal precautions appropriate to handling integrated circuits.

## 15. Soldering of SMD packages

---

This text provides a very brief insight into a complex technology. A more in-depth account of soldering ICs can be found in Application Note *AN10365 "Surface mount reflow soldering description"*.

### 15.1 Introduction to soldering

Soldering is one of the most common methods through which packages are attached to Printed Circuit Boards (PCBs), to form electrical circuits. The soldered joint provides both the mechanical and the electrical connection. There is no single soldering method that is ideal for all IC packages. Wave soldering is often preferred when through-hole and Surface Mount Devices (SMDs) are mixed on one printed wiring board; however, it is not suitable for fine pitch SMDs. Reflow soldering is ideal for the small pitches and high densities that come with increased miniaturization.

### 15.2 Wave and reflow soldering

Wave soldering is a joining technology in which the joints are made by solder coming from a standing wave of liquid solder. The wave soldering process is suitable for the following:

- Through-hole components
- Leaded or leadless SMDs, which are glued to the surface of the printed circuit board

Not all SMDs can be wave soldered. Packages with solder balls, and some leadless packages which have solder lands underneath the body, cannot be wave soldered. Also, leaded SMDs with leads having a pitch smaller than ~0.6 mm cannot be wave soldered, due to an increased probability of bridging.

The reflow soldering process involves applying solder paste to a board, followed by component placement and exposure to a temperature profile. Leaded packages, packages with solder balls, and leadless packages are all reflow solderable.

Key characteristics in both wave and reflow soldering are:

- Board specifications, including the board finish, solder masks and vias
- Package footprints, including solder thieves and orientation
- The moisture sensitivity level of the packages
- Package placement
- Inspection and repair
- Lead-free soldering versus SnPb soldering

### 15.3 Wave soldering

Key characteristics in wave soldering are:

- Process issues, such as application of adhesive and flux, clinching of leads, board transport, the solder wave parameters, and the time during which components are exposed to the wave
- Solder bath specifications, including temperature and impurities

## 15.4 Reflow soldering

Key characteristics in reflow soldering are:

- Lead-free versus SnPb soldering; note that a lead-free reflow process usually leads to higher minimum peak temperatures (see [Figure 26](#)) than a SnPb process, thus reducing the process window
- Solder paste printing issues including smearing, release, and adjusting the process window for a mix of large and small components on one board
- Reflow temperature profile; this profile includes preheat, reflow (in which the board is heated to the peak temperature) and cooling down. It is imperative that the peak temperature is high enough for the solder to make reliable solder joints (a solder paste characteristic). In addition, the peak temperature must be low enough that the packages and/or boards are not damaged. The peak temperature of the package depends on package thickness and volume and is classified in accordance with [Table 12](#) and [13](#)

**Table 12. SnPb eutectic process (from J-STD-020C)**

Package thickness (mm)	Package reflow temperature (°C)	
	Volume (mm <sup>3</sup> )	
	< 350	≥ 350
< 2.5	235	220
≥ 2.5	220	220

**Table 13. Lead-free process (from J-STD-020C)**

Package thickness (mm)	Package reflow temperature (°C)		
	Volume (mm <sup>3</sup> )		
	< 350	350 to 2000	> 2000
< 1.6	260	260	260
1.6 to 2.5	260	250	245
> 2.5	250	245	245

Moisture sensitivity precautions, as indicated on the packing, must be respected at all times.

Studies have shown that small packages reach higher temperatures during reflow soldering, see [Figure 26](#).

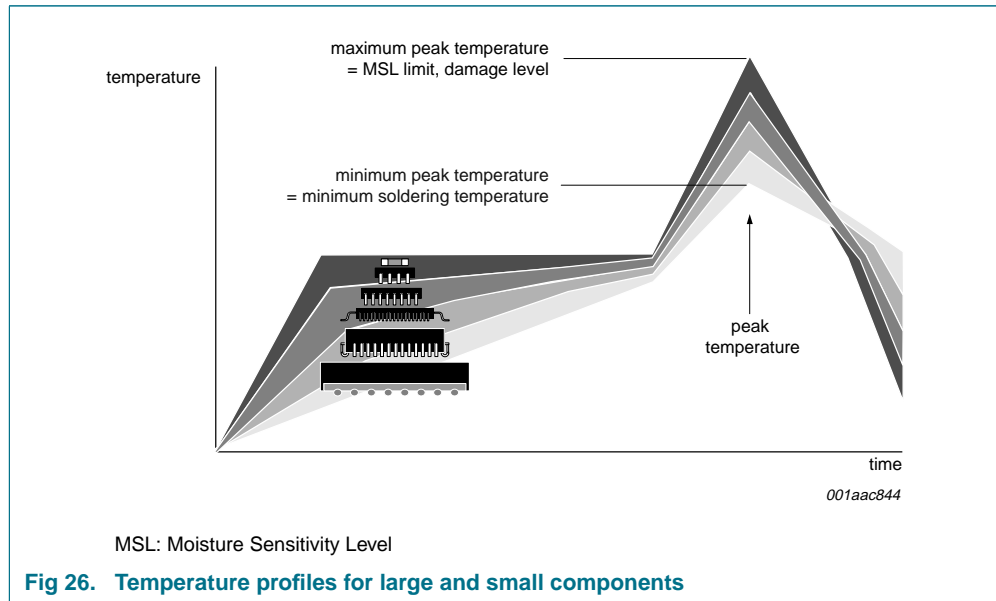

For further information on temperature profiles, refer to Application Note AN10365 “Surface mount reflow soldering description”.

## 16. Abbreviations

**Table 14. Abbreviations**

Acronym	Description
CBT	Cross Bar Technology
CDM	Charged-Device Model
CMOS	Complementary Metal-Oxide Semiconductor
ESD	ElectroStatic Discharge
HBM	Human Body Model
I <sup>2</sup> C-bus	Inter-Integrated Circuit bus
I/O	Input/Output
LED	Light-Emitting Diode
MM	Machine Model
PCB	Printed-Circuit Board
POR	Power-On Reset
SMBus	System Management Bus

## 17. Revision history

Table 15. Revision history

Document ID	Release date	Data sheet status	Change notice	Supersedes
PCA9557_6	20080611	Product data sheet	-	PCA9557_5
Modifications:	<ul style="list-style-type: none"> <li>• <a href="#">Section 2 "Features"</a>, 17<sup>th</sup> bullet item: changed from "200 V MM" to "150 V MM"</li> <li>• <a href="#">Table 11 "Dynamic characteristics"</a>, sub-section "Reset timing": changed Min value for <math>t_{w(rst)}</math> from "4 ns" to "6 ns" (for both Standard-mode and Fast-mode)</li> <li>• Updated soldering information</li> </ul>			
PCA9557_5	20070912	Product data sheet	-	PCA9557_4
PCA9557_4 (9397 750 13336)	20041124	Product data sheet	-	PCA9557_3
PCA9557_3 (9397 750 10872)	20021213	Product data	ECN 853-2308 29160 of 06 Nov 2002	PCA9557_2
PCA9557_2 (9397 750 09819)	20020513	Product data	ECN 853-2308 28188 of 13 May 2002	PCA9557_1
PCA9557_1	20011212	Product data	ECN 853-2308 27449 of 12 Dec 2001	-



## 18. Legal information

### 18.1 Data sheet status

Document status <sup>[1][2]</sup>	Product status <sup>[3]</sup>	Definition
Objective [short] data sheet	Development	This document contains data from the objective specification for product development.
Preliminary [short] data sheet	Qualification	This document contains data from the preliminary specification.
Product [short] data sheet	Production	This document contains the product specification.

[1] Please consult the most recently issued document before initiating or completing a design.

[2] The term 'short data sheet' is explained in section "Definitions".

[3] The product status of device(s) described in this document may have changed since this document was published and may differ in case of multiple devices. The latest product status information is available on the Internet at URL <http://www.nxp.com>.

### 18.2 Definitions

**Draft** — The document is a draft version only. The content is still under internal review and subject to formal approval, which may result in modifications or additions. NXP Semiconductors does not give any representations or warranties as to the accuracy or completeness of information included herein and shall have no liability for the consequences of use of such information.

**Short data sheet** — A short data sheet is an extract from a full data sheet with the same product type number(s) and title. A short data sheet is intended for quick reference only and should not be relied upon to contain detailed and full information. For detailed and full information see the relevant full data sheet, which is available on request via the local NXP Semiconductors sales office. In case of any inconsistency or conflict with the short data sheet, the full data sheet shall prevail.

### 18.3 Disclaimers

**General** — Information in this document is believed to be accurate and reliable. However, NXP Semiconductors does not give any representations or warranties, expressed or implied, as to the accuracy or completeness of such information and shall have no liability for the consequences of use of such information.

**Right to make changes** — NXP Semiconductors reserves the right to make changes to information published in this document, including without limitation specifications and product descriptions, at any time and without notice. This document supersedes and replaces all information supplied prior to the publication hereof.

**Suitability for use** — NXP Semiconductors products are not designed, authorized or warranted to be suitable for use in medical, military, aircraft, space or life support equipment, nor in applications where failure or malfunction of an NXP Semiconductors product can reasonably be expected

to result in personal injury, death or severe property or environmental damage. NXP Semiconductors accepts no liability for inclusion and/or use of NXP Semiconductors products in such equipment or applications and therefore such inclusion and/or use is at the customer's own risk.

**Applications** — Applications that are described herein for any of these products are for illustrative purposes only. NXP Semiconductors makes no representation or warranty that such applications will be suitable for the specified use without further testing or modification.

**Limiting values** — Stress above one or more limiting values (as defined in the Absolute Maximum Ratings System of IEC 60134) may cause permanent damage to the device. Limiting values are stress ratings only and operation of the device at these or any other conditions above those given in the Characteristics sections of this document is not implied. Exposure to limiting values for extended periods may affect device reliability.

**Terms and conditions of sale** — NXP Semiconductors products are sold subject to the general terms and conditions of commercial sale, as published at <http://www.nxp.com/profile/terms>, including those pertaining to warranty, intellectual property rights infringement and limitation of liability, unless explicitly otherwise agreed to in writing by NXP Semiconductors. In case of any inconsistency or conflict between information in this document and such terms and conditions, the latter will prevail.

**No offer to sell or license** — Nothing in this document may be interpreted or construed as an offer to sell products that is open for acceptance or the grant, conveyance or implication of any license under any copyrights, patents or other industrial or intellectual property rights.

### 18.4 Trademarks

Notice: All referenced brands, product names, service names and trademarks are the property of their respective owners.

**I<sup>2</sup>C-bus** — logo is a trademark of NXP B.V.

## 19. Contact information

For more information, please visit: <http://www.nxp.com>

For sales office addresses, please send an email to: [salesaddresses@nxp.com](mailto:salesaddresses@nxp.com)

## 20. Contents

<b>1</b>	<b>General description</b> .....	<b>1</b>	<b>18.4</b>	<b>Trademarks</b> .....	<b>25</b>
<b>2</b>	<b>Features</b> .....	<b>1</b>	<b>19</b>	<b>Contact information</b> .....	<b>25</b>
<b>3</b>	<b>Ordering information</b> .....	<b>2</b>	<b>20</b>	<b>Contents</b> .....	<b>26</b>
3.1	Ordering options .....	2			
<b>4</b>	<b>Block diagram</b> .....	<b>2</b>			
<b>5</b>	<b>Pinning information</b> .....	<b>5</b>			
5.1	Pinning .....	5			
5.2	Pin description .....	5			
<b>6</b>	<b>System diagram</b> .....	<b>6</b>			
<b>7</b>	<b>Functional description</b> .....	<b>7</b>			
7.1	Device address .....	7			
7.2	Control register .....	7			
7.3	Register descriptions .....	8			
7.3.1	Register 0 - Input port register .....	8			
7.3.2	Register 1 - Output port register .....	8			
7.3.3	Register 2 - Polarity inversion register .....	8			
7.3.4	Register 3 - Configuration register .....	8			
7.4	Power-on reset .....	9			
7.5	RESET input .....	9			
<b>8</b>	<b>Characteristics of the I<sup>2</sup>C-bus</b> .....	<b>9</b>			
8.1	Bit transfer .....	9			
8.1.1	START and STOP conditions .....	9			
8.2	System configuration .....	10			
8.3	Acknowledge .....	10			
8.4	Bus transactions .....	11			
<b>9</b>	<b>Application design-in information</b> .....	<b>13</b>			
9.1	Minimizing I <sub>DD</sub> when the I/Os are used to control LEDs .....	13			
<b>10</b>	<b>Limiting values</b> .....	<b>14</b>			
<b>11</b>	<b>Static characteristics</b> .....	<b>15</b>			
<b>12</b>	<b>Dynamic characteristics</b> .....	<b>16</b>			
<b>13</b>	<b>Package outline</b> .....	<b>18</b>			
<b>14</b>	<b>Handling information</b> .....	<b>21</b>			
<b>15</b>	<b>Soldering of SMD packages</b> .....	<b>21</b>			
15.1	Introduction to soldering .....	21			
15.2	Wave and reflow soldering .....	21			
15.3	Wave soldering .....	21			
15.4	Reflow soldering .....	22			
<b>16</b>	<b>Abbreviations</b> .....	<b>23</b>			
<b>17</b>	<b>Revision history</b> .....	<b>24</b>			
<b>18</b>	<b>Legal information</b> .....	<b>25</b>			
18.1	Data sheet status .....	25			
18.2	Definitions .....	25			
18.3	Disclaimers .....	25			

Please be aware that important notices concerning this document and the product(s) described herein, have been included in section 'Legal information'.



© NXP B.V. 2008.

All rights reserved.

For more information, please visit: <http://www.nxp.com>

For sales office addresses, please send an email to: [salesaddresses@nxp.com](mailto:salesaddresses@nxp.com)

Date of release: 11 June 2008

Document identifier: PCA9557