



# BF545A; BF545B; BF545C

N-channel silicon junction field-effect transistors

Rev. 4 — 15 September 2011

Product data sheet

## 1. Product profile

### 1.1 General description

N-channel symmetrical silicon junction field-effect transistors in a SOT23 package.

#### CAUTION



This device is sensitive to ElectroStatic Discharge (ESD). Therefore care should be taken during transport and handling.

### 1.2 Features and benefits

- Low leakage level (typ. 500 fA)
- High gain
- Low cut-off voltage (max. 2.2 V for BF545A).

### 1.3 Applications

- Impedance converters in e.g. electret microphones and infra-red detectors
- VHF amplifiers in oscillators and mixers.

### 1.4 Quick reference data

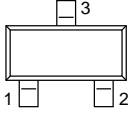

Table 1. Quick reference data

Symbol	Parameter	Conditions	Min	Typ	Max	Unit
$V_{DS}$	drain-source voltage		-	-	$\pm 30$	V
$V_{GSoff}$	gate-source cut-off voltage	$I_D = 1 \mu A$ ; $V_{DS} = 15 V$	-0.4	-	-7.8	V
$I_{DSS}$	drain current	$V_{GS} = 0 V$ ; $V_{DS} = 15 V$				
		BF545A	2	-	6.5	mA
		BF545B	6	-	15	mA
	BF545C	12	-	25	mA	
$P_{tot}$	total power dissipation	$T_{amb} \leq 25 \text{ }^\circ C$	-	-	250	mW
$ y_{fs} $	forward transfer admittance	$V_{GS} = 0 V$ ; $V_{DS} = 15 V$	3	-	6.5	mS



## 2. Pinning information

Table 2. Pinning

Pin	Description	Simplified outline	Symbol
1	source (s)		 sym054
2	drain (d)		
3	gate (g)		

## 3. Ordering information

Table 3. Ordering information

Type number	Package		
	Name	Description	Version
BF545A	-	plastic surface mounted package; 3 leads	SOT23
BF545B			
BF545C			

## 4. Marking

Table 4. Marking

Type number	Marking code <sup>[1]</sup>
BF545A	20*
BF545B	21*
BF545C	22*

[1] \* = p: made in Hong Kong.

\* = t: made in Malaysia.

\* = W: made in China.

## 5. Limiting values

**Table 5. Limiting values**

In accordance with the Absolute Maximum Rating System (IEC 60134).

Symbol	Parameter	Conditions	Min	Max	Unit
$V_{DS}$	drain-source voltage (DC)		-	$\pm 30$	V
$V_{GSO}$	gate-source voltage	open drain	-	-30	V
$V_{GDO}$	gate-drain voltage (DC)	open source	-	-30	V
$I_G$	forward gate current (DC)		-	10	mA
$P_{tot}$	total power dissipation	$T_{amb} \leq 25\text{ °C}$	[1] -	250	mW
$T_{stg}$	storage temperature		-65	+150	°C
$T_j$	junction temperature		-	150	°C

[1] Device mounted on an FR4 printed-circuit board, maximum lead length 4 mm; mounting pad for the drain lead 10 mm<sup>2</sup>.

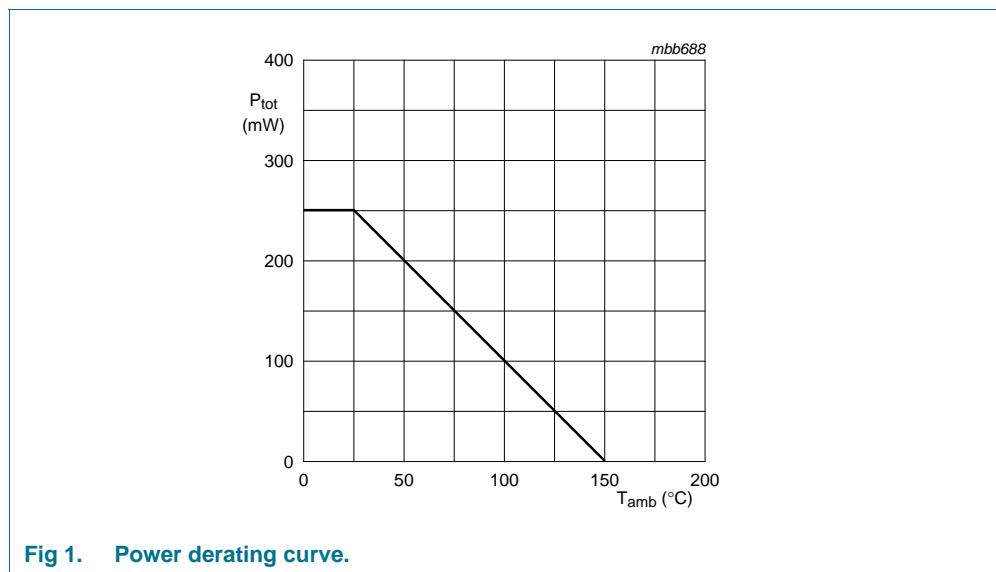

**Fig 1. Power derating curve.**

## 6. Thermal characteristics

**Table 6. Thermal characteristics**

Symbol	Parameter	Conditions	Typ	Unit
$R_{th(j-a)}$	thermal resistance from junction to ambient		[1] 500	K/W

[1] Device mounted on an FR4 printed-circuit board, maximum lead length 4 mm; mounting pad for the drain lead 10 mm<sup>2</sup>.

## 7. Static characteristics

**Table 7. Static characteristics***T<sub>j</sub> = 25 °C unless otherwise specified.*

Symbol	Parameter	Conditions	Min	Typ	Max	Unit
V <sub>(BR)GSS</sub>	gate-source breakdown voltage	I <sub>G</sub> = -1 μA; V <sub>DS</sub> = 0 V	-30	-	-	V
V <sub>GSoff</sub>	gate-source cut-off voltage	I <sub>D</sub> = 200 μA; V <sub>DS</sub> = 15 V				
		BF545A	-0.4	-	-2.2	V
		BF545B	-1.6	-	-3.8	V
		BF545C	-3.2	-	-7.8	V
I <sub>DSS</sub>	drain current	I <sub>D</sub> = 1 μA; V <sub>DS</sub> = 15 V	-0.4	-	-7.5	V
		V <sub>GS</sub> = 0 V; V <sub>DS</sub> = 15 V				
		BF545A	2	-	6.5	mA
		BF545B	6	-	15	mA
I <sub>GSS</sub>	gate-source leakage current	V <sub>GS</sub> = -20 V; V <sub>DS</sub> = 0 V	-	-0.5	-1000	pA
		V <sub>GS</sub> = -20 V; V <sub>DS</sub> = 0 V; T <sub>j</sub> = 125 °C	-	-	-100	nA
y <sub>fs</sub>	forward transfer admittance	V <sub>GS</sub> = 0 V; V <sub>DS</sub> = 15 V	3	-	6.5	mS
y <sub>os</sub>	common source output admittance	V <sub>GS</sub> = 0 V; V <sub>DS</sub> = 15 V	-	40	-	μS

## 8. Dynamic characteristics

**Table 8. Dynamic characteristics**  
*T<sub>amb</sub> = 25 °C unless otherwise specified.*

Symbol	Parameter	Conditions	Min	Typ	Max	Unit
C <sub>iss</sub>	input capacitance	V <sub>DS</sub> = 15 V; f = 1 MHz				
		V <sub>GS</sub> = -10 V	-	1.7	-	pF
		V <sub>GS</sub> = 0 V	-	3	-	pF
C <sub>rss</sub>	reverse transfer capacitance	V <sub>DS</sub> = 15 V; f = 1 MHz				
		V <sub>GS</sub> = -10 V	-	0.8	-	pF
		V <sub>GS</sub> = 0 V	-	0.9	-	pF
g <sub>is</sub>	common source input conductance	V <sub>DS</sub> = 10 V; I <sub>D</sub> = 1 mA				
		f = 100 MHz	-	15	-	μS
		f = 450 MHz	-	300	-	μS
g <sub>fs</sub>	common source transfer conductance	V <sub>DS</sub> = 10 V; I <sub>D</sub> = 1 mA				
		f = 100 MHz	-	2	-	mS
		f = 450 MHz	-	1.8	-	mS
g <sub>rs</sub>	common source reverse conductance	V <sub>DS</sub> = 10 V; I <sub>D</sub> = 1 mA				
		f = 100 MHz	-	-6	-	μS
		f = 450 MHz	-	-40	-	μS
g <sub>os</sub>	common source output conductance	V <sub>DS</sub> = 10 V; I <sub>D</sub> = 1 mA				
		f = 100 MHz	-	30	-	μS
		f = 450 MHz	-	60	-	μS

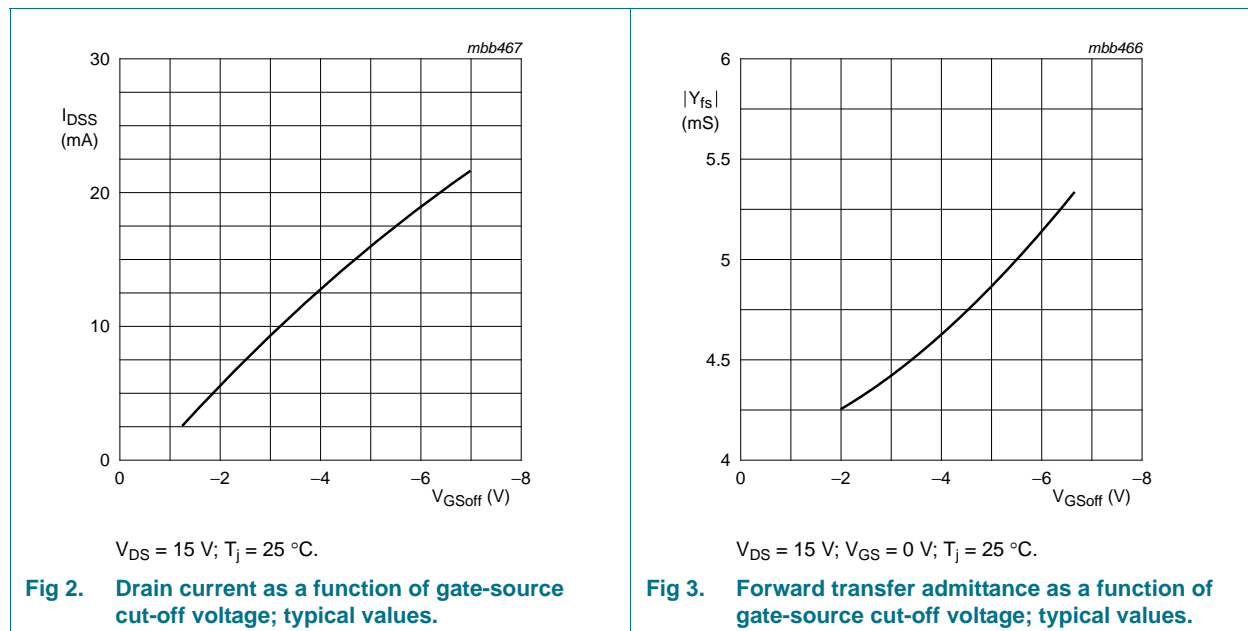

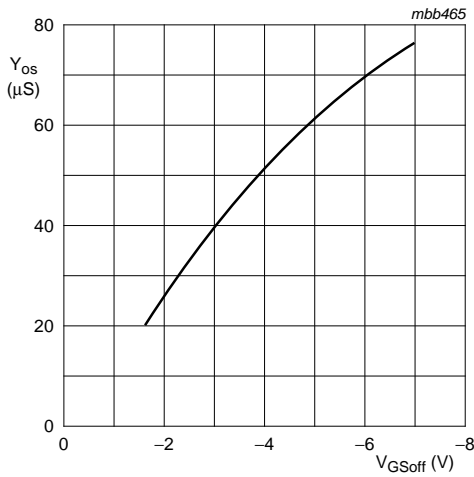

$V_{DS} = 15 V$ ;  $V_{GS} = 0 V$ ;  $T_j = 25 ^\circ C$ .

**Fig 4. Common-source output admittance as a function of gate-source cut-off voltage; typical values.**

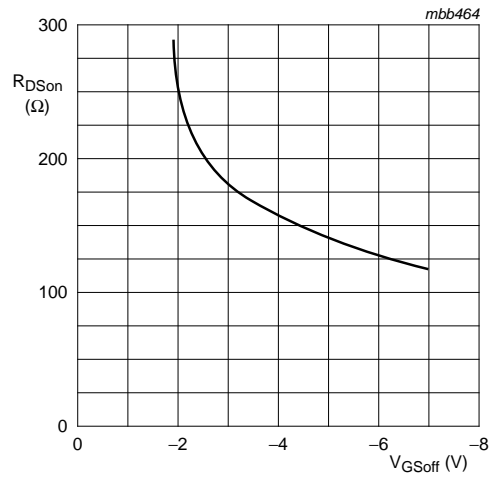

$V_{DS} = 100 mV$ ;  $V_{GS} = 0 V$ ;  $T_j = 25 ^\circ C$ .

**Fig 5. Drain-source on-resistance as a function of gate-source cut-off voltage; typical values.**

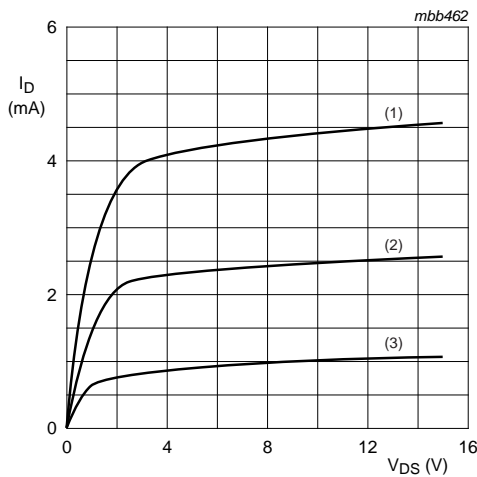

**BF545A**  
 $T_j = 25 ^\circ C$ .

- (1)  $V_{GS} = 0 V$ .
- (2)  $V_{GS} = -0.5 V$ .
- (3)  $V_{GS} = -1.0 V$ .

**Fig 6. Typical output characteristics.**

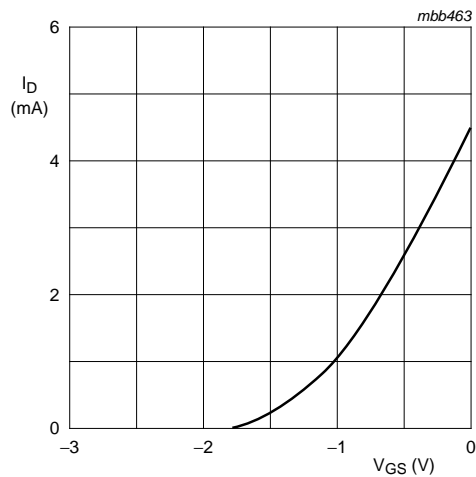

**BF545A**  
 $V_{DS} = 15 V$ ;  $T_j = 25 ^\circ C$ .

**Fig 7. Typical input characteristics.**

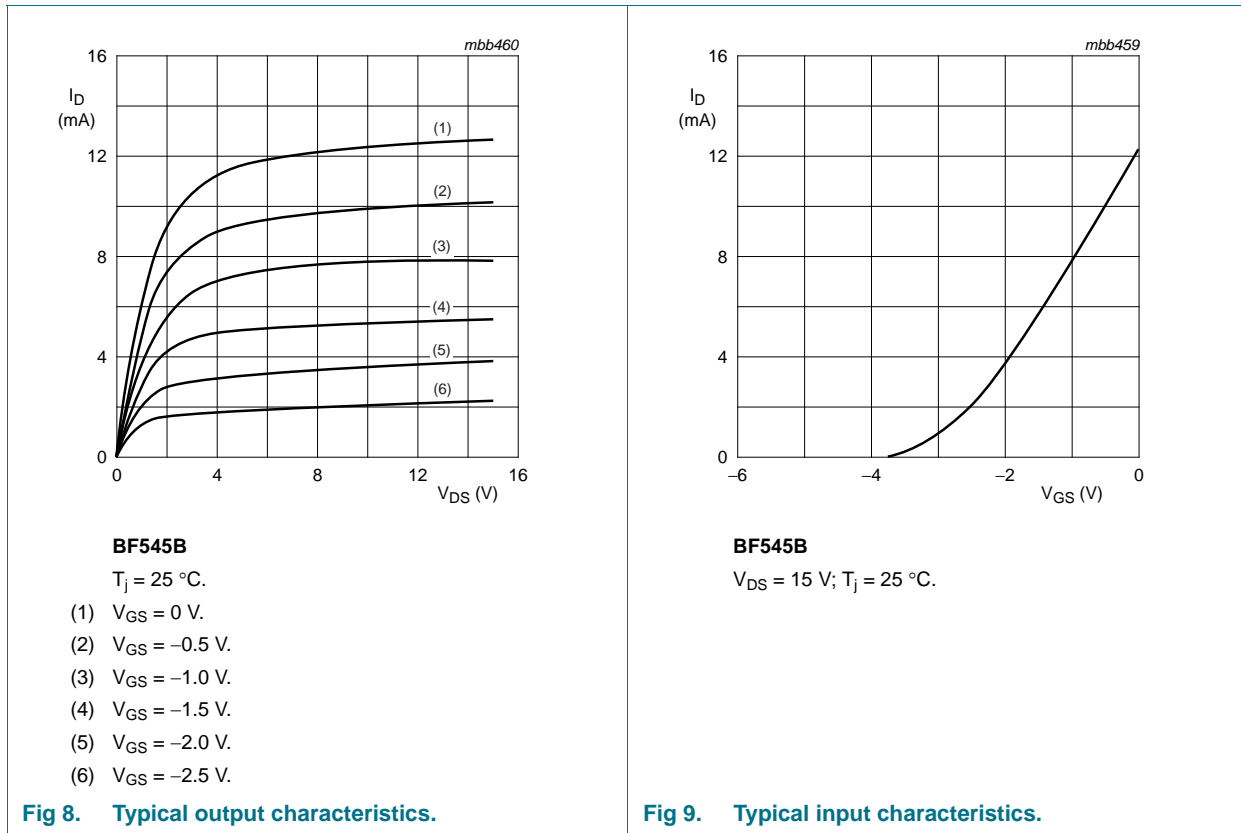

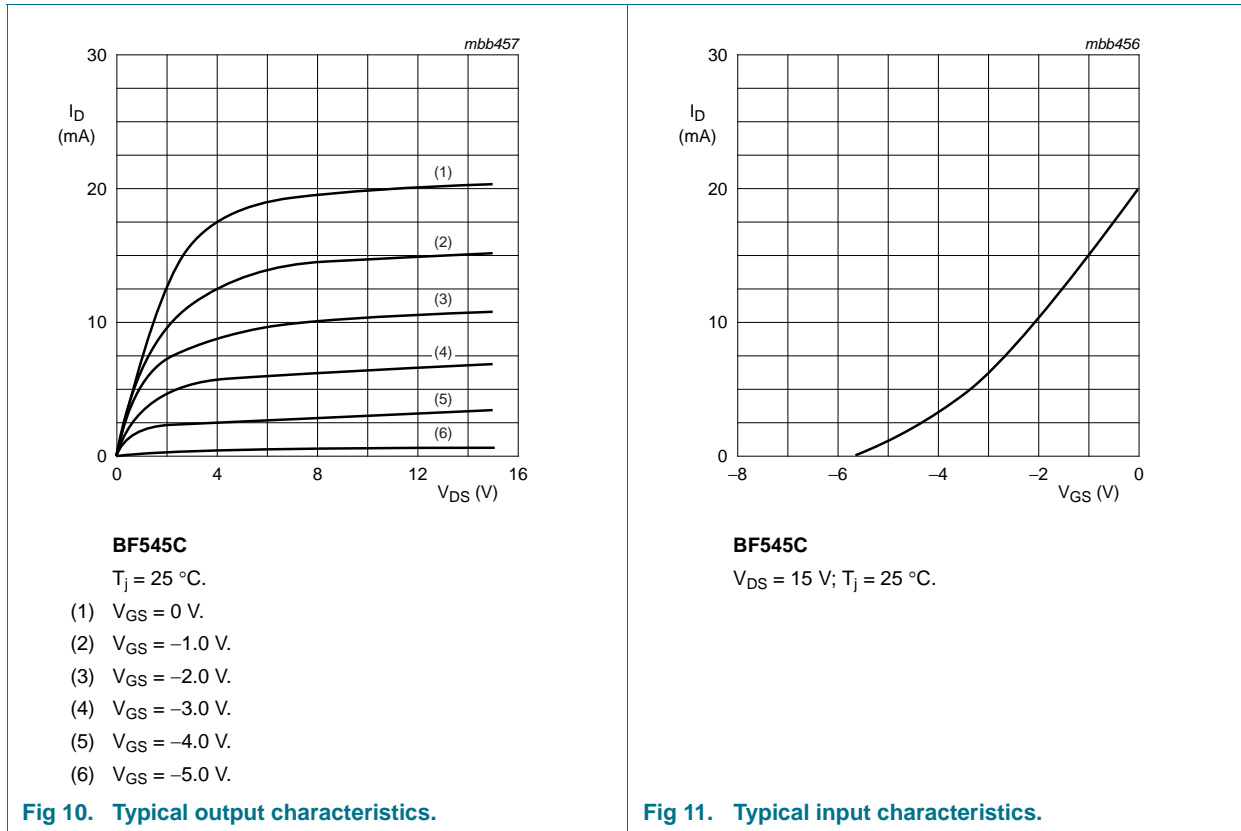



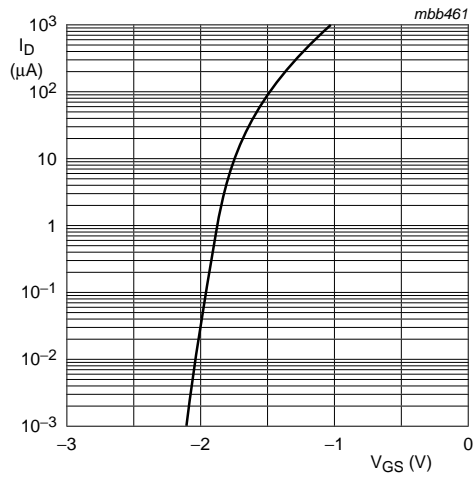

**BF545A**

$V_{DS} = 15\text{ V}; T_j = 25\text{ }^\circ\text{C}.$

**Fig 12. Drain current as a function of gate-source voltage; typical values.**

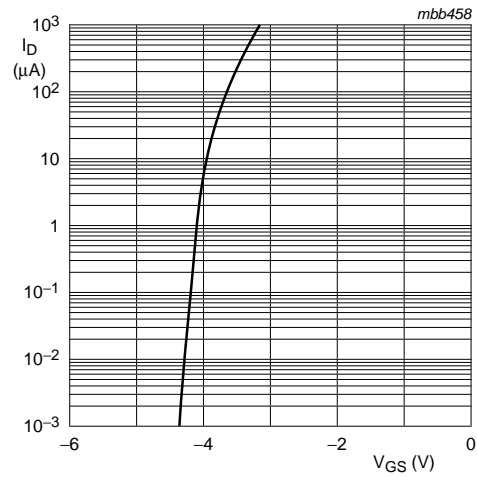

**BF545B**

$V_{DS} = 15\text{ V}; T_j = 25\text{ }^\circ\text{C}.$

**Fig 13. Drain current as a function of gate-source voltage; typical values.**

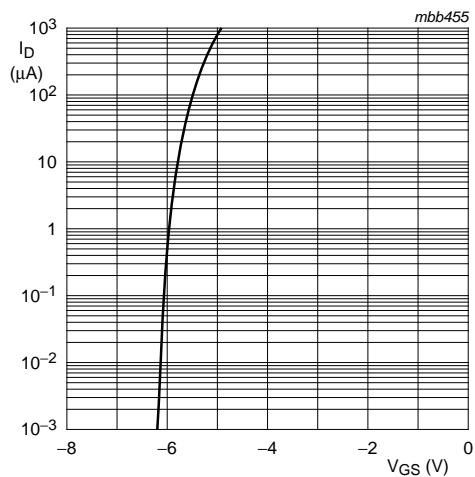

**BF545C**

$V_{DS} = 15\text{ V}; T_j = 25\text{ }^\circ\text{C}.$

**Fig 14. Drain current as a function of gate-source voltage; typical values.**

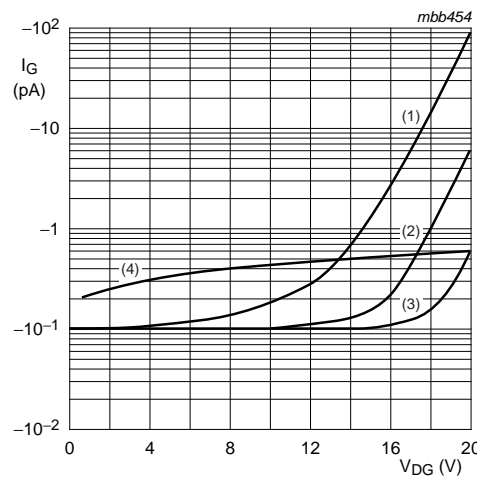

$I_D = 10\text{ mA}$  only for BF545B and BF545C;  $T_j = 25\text{ }^\circ\text{C}.$

- (1)  $I_D = 10\text{ mA}.$
- (2)  $I_D = 1\text{ mA}.$
- (3)  $I_D = 0.1\text{ mA}.$
- (4)  $I_{GSS}.$

**Fig 15. Gate current as a function of drain-gate voltage; typical values.**

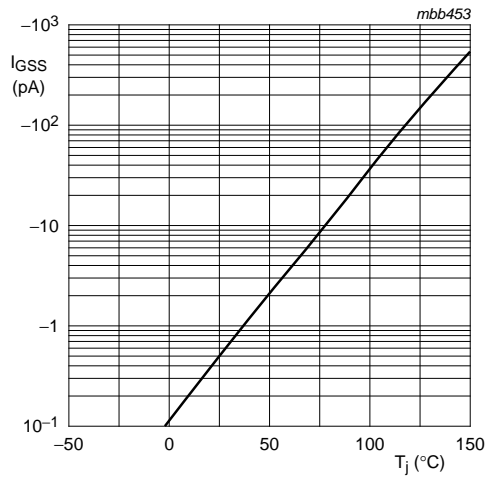

$V_{DS} = 0\text{ V}; V_{GS} = -20\text{ V}.$

**Fig 16. Gate current as a function of junction temperature; typical values.**

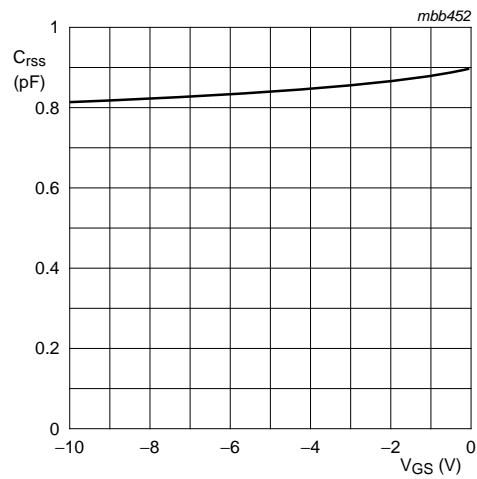

$V_{DS} = 15\text{ V}; T_j = 25\text{ °C}.$

**Fig 17. Reverse transfer capacitance as a function of gate-source voltage; typical values.**

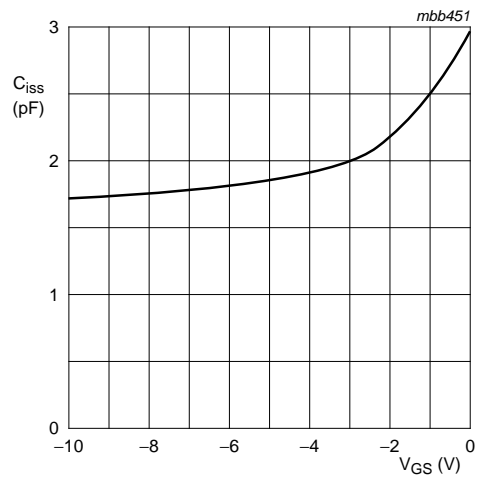

$V_{DS} = 15\text{ V}; T_j = 25\text{ °C}.$

**Fig 18. Typical input capacitance.**

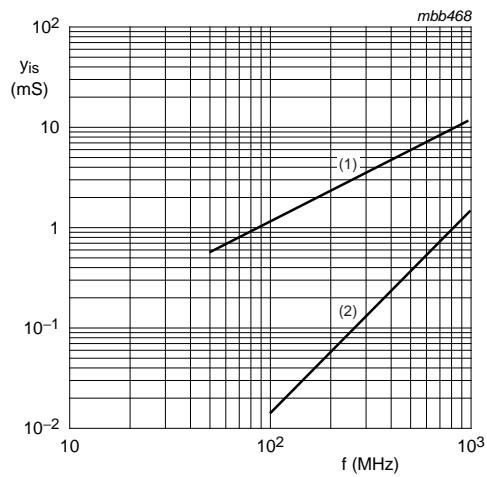

$V_{DS} = 10\text{ V}; I_D = 1\text{ mA}; T_{amb} = 25\text{ °C}.$

- (1)  $b_{is}$ .
- (2)  $g_{is}$ .

**Fig 19. Common-source input admittance; typical values.**

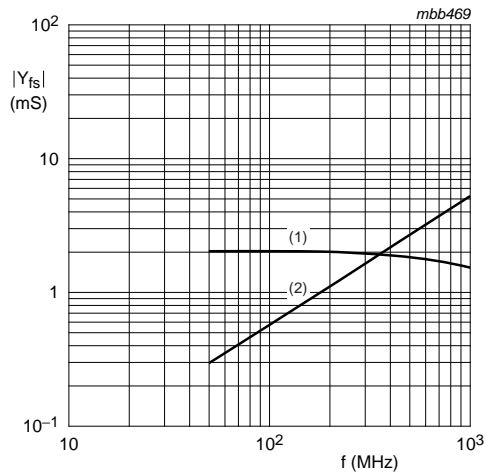

$V_{DS} = 10\text{ V}; I_D = 1\text{ mA}; T_{amb} = 25\text{ }^\circ\text{C}.$

- (1)  $g_{fs}$ .
- (2)  $-b_{fs}$ .

**Fig 20. Common-source forward transfer admittance; typical values.**

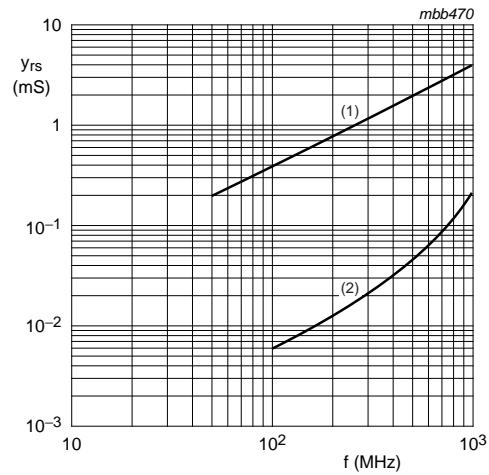

$V_{DS} = 10\text{ V}; I_D = 1\text{ mA}; T_{amb} = 25\text{ }^\circ\text{C}.$

- (1)  $-b_{rs}$ .
- (2)  $-g_{rs}$ .

**Fig 21. Common-source reverse transfer admittance; typical values.**

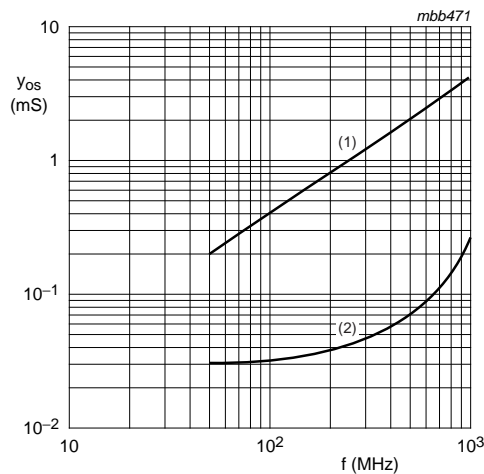

$V_{DS} = 10\text{ V}; I_D = 1\text{ mA}; T_{amb} = 25\text{ }^\circ\text{C}.$

- (1)  $b_{os}$ .
- (2)  $g_{os}$ .

**Fig 22. Common-source output admittance; typical values.**

## 9. Package outline

Plastic surface-mounted package; 3 leads

SOT23

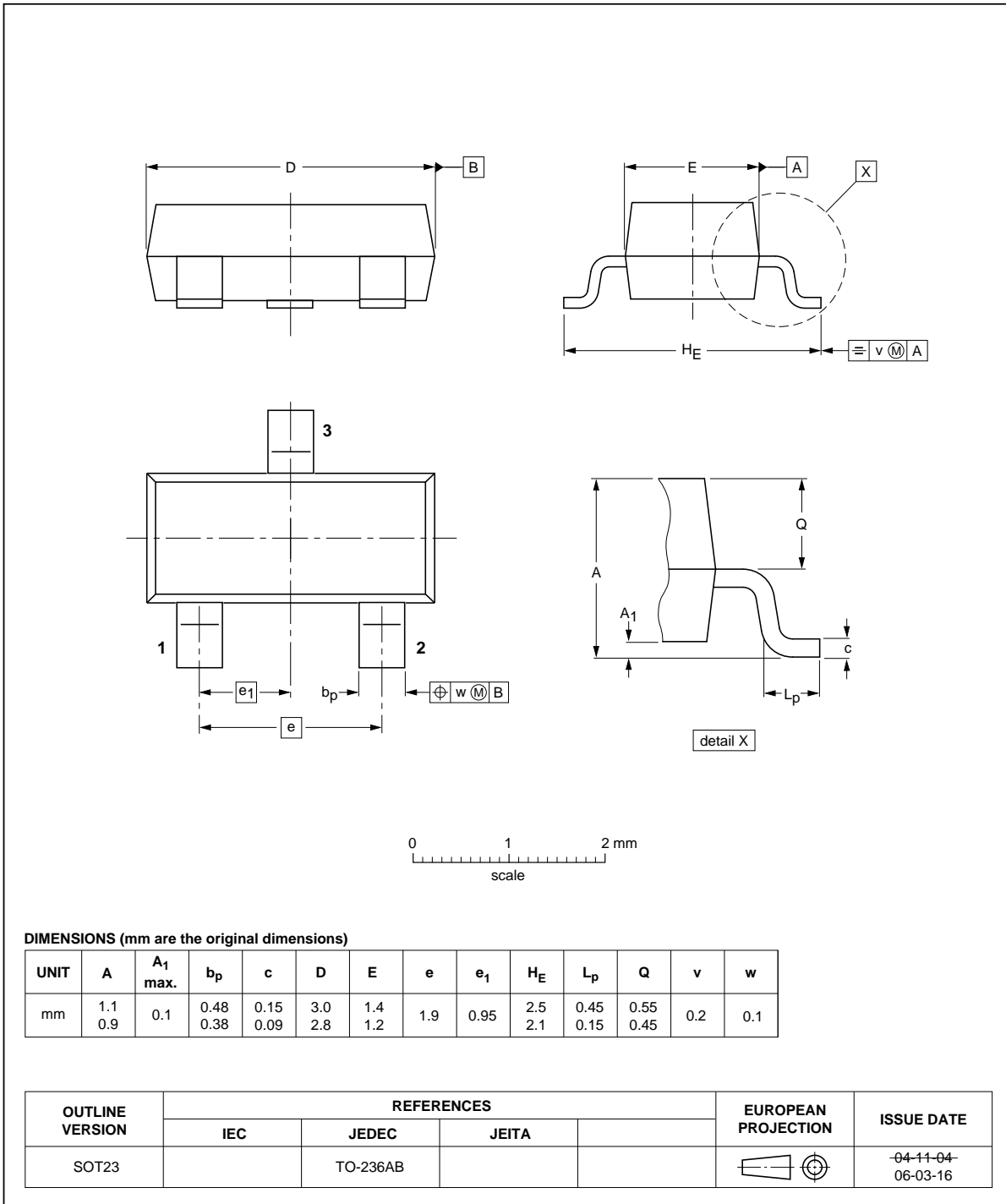

Fig 23. Package outline.

## 10. Revision history

**Table 9. Revision history**

Document ID	Release date	Data sheet status	Change notice	Supersedes
BF545A_BF545B_BF545C v.4	20110915	Product data sheet	-	BF545A_BF545B_BF545C v.3
Modifications:		<ul style="list-style-type: none"> <li>• The format of this data sheet has been redesigned to comply with the new identity guidelines of NXP Semiconductors.</li> <li>• Legal texts have been adapted to the new company name where appropriate.</li> <li>• Package outline drawings have been updated to the latest version.</li> </ul>		
BF545A_BF545B_BF545C v.3 (9397 750 13391)	20040805	Product data sheet	-	BF545A-B-C v.2
BF545A-B-C v.2	19960729	Product specification	-	-

## 11. Legal information

### 11.1 Data sheet status

Document status <sup>[1][2]</sup>	Product status <sup>[3]</sup>	Definition
Objective [short] data sheet	Development	This document contains data from the objective specification for product development.
Preliminary [short] data sheet	Qualification	This document contains data from the preliminary specification.
Product [short] data sheet	Production	This document contains the product specification.

[1] Please consult the most recently issued document before initiating or completing a design.

[2] The term 'short data sheet' is explained in section "Definitions".

[3] The product status of device(s) described in this document may have changed since this document was published and may differ in case of multiple devices. The latest product status information is available on the Internet at URL <http://www.nxp.com>.

### 11.2 Definitions

**Draft** — The document is a draft version only. The content is still under internal review and subject to formal approval, which may result in modifications or additions. NXP Semiconductors does not give any representations or warranties as to the accuracy or completeness of information included herein and shall have no liability for the consequences of use of such information.

**Short data sheet** — A short data sheet is an extract from a full data sheet with the same product type number(s) and title. A short data sheet is intended for quick reference only and should not be relied upon to contain detailed and full information. For detailed and full information see the relevant full data sheet, which is available on request via the local NXP Semiconductors sales office. In case of any inconsistency or conflict with the short data sheet, the full data sheet shall prevail.

**Product specification** — The information and data provided in a Product data sheet shall define the specification of the product as agreed between NXP Semiconductors and its customer, unless NXP Semiconductors and customer have explicitly agreed otherwise in writing. In no event however, shall an agreement be valid in which the NXP Semiconductors product is deemed to offer functions and qualities beyond those described in the Product data sheet.

### 11.3 Disclaimers

**Limited warranty and liability** — Information in this document is believed to be accurate and reliable. However, NXP Semiconductors does not give any representations or warranties, expressed or implied, as to the accuracy or completeness of such information and shall have no liability for the consequences of use of such information.

In no event shall NXP Semiconductors be liable for any indirect, incidental, punitive, special or consequential damages (including - without limitation - lost profits, lost savings, business interruption, costs related to the removal or replacement of any products or rework charges) whether or not such damages are based on tort (including negligence), warranty, breach of contract or any other legal theory.

Notwithstanding any damages that customer might incur for any reason whatsoever, NXP Semiconductors' aggregate and cumulative liability towards customer for the products described herein shall be limited in accordance with the *Terms and conditions of commercial sale* of NXP Semiconductors.

**Right to make changes** — NXP Semiconductors reserves the right to make changes to information published in this document, including without limitation specifications and product descriptions, at any time and without notice. This document supersedes and replaces all information supplied prior to the publication hereof.

**Suitability for use** — NXP Semiconductors products are not designed, authorized or warranted to be suitable for use in life support, life-critical or safety-critical systems or equipment, nor in applications where failure or

malfunction of an NXP Semiconductors product can reasonably be expected to result in personal injury, death or severe property or environmental damage. NXP Semiconductors accepts no liability for inclusion and/or use of NXP Semiconductors products in such equipment or applications and therefore such inclusion and/or use is at the customer's own risk.

**Applications** — Applications that are described herein for any of these products are for illustrative purposes only. NXP Semiconductors makes no representation or warranty that such applications will be suitable for the specified use without further testing or modification.

Customers are responsible for the design and operation of their applications and products using NXP Semiconductors products, and NXP Semiconductors accepts no liability for any assistance with applications or customer product design. It is customer's sole responsibility to determine whether the NXP Semiconductors product is suitable and fit for the customer's applications and products planned, as well as for the planned application and use of customer's third party customer(s). Customers should provide appropriate design and operating safeguards to minimize the risks associated with their applications and products.

NXP Semiconductors does not accept any liability related to any default, damage, costs or problem which is based on any weakness or default in the customer's applications or products, or the application or use by customer's third party customer(s). Customer is responsible for doing all necessary testing for the customer's applications and products using NXP Semiconductors products in order to avoid a default of the applications and the products or of the application or use by customer's third party customer(s). NXP does not accept any liability in this respect.

**Limiting values** — Stress above one or more limiting values (as defined in the Absolute Maximum Ratings System of IEC 60134) will cause permanent damage to the device. Limiting values are stress ratings only and (proper) operation of the device at these or any other conditions above those given in the Recommended operating conditions section (if present) or the Characteristics sections of this document is not warranted. Constant or repeated exposure to limiting values will permanently and irreversibly affect the quality and reliability of the device.

**Terms and conditions of commercial sale** — NXP Semiconductors products are sold subject to the general terms and conditions of commercial sale, as published at <http://www.nxp.com/profile/terms>, unless otherwise agreed in a valid written individual agreement. In case an individual agreement is concluded only the terms and conditions of the respective agreement shall apply. NXP Semiconductors hereby expressly objects to applying the customer's general terms and conditions with regard to the purchase of NXP Semiconductors products by customer.

**No offer to sell or license** — Nothing in this document may be interpreted or construed as an offer to sell products that is open for acceptance or the grant, conveyance or implication of any license under any copyrights, patents or other industrial or intellectual property rights.

**Export control** — This document as well as the item(s) described herein may be subject to export control regulations. Export might require a prior authorization from national authorities.

**Quick reference data** — The Quick reference data is an extract of the product data given in the Limiting values and Characteristics sections of this document, and as such is not complete, exhaustive or legally binding.

**Non-automotive qualified products** — Unless this data sheet expressly states that this specific NXP Semiconductors product is automotive qualified, the product is not suitable for automotive use. It is neither qualified nor tested in accordance with automotive testing or application requirements. NXP Semiconductors accepts no liability for inclusion and/or use of non-automotive qualified products in automotive equipment or applications.

In the event that customer uses the product for design-in and use in automotive applications to automotive specifications and standards, customer (a) shall use the product without NXP Semiconductors' warranty of the

product for such automotive applications, use and specifications, and (b) whenever customer uses the product for automotive applications beyond NXP Semiconductors' specifications such use shall be solely at customer's own risk, and (c) customer fully indemnifies NXP Semiconductors for any liability, damages or failed product claims resulting from customer design and use of the product for automotive applications beyond NXP Semiconductors' standard warranty and NXP Semiconductors' product specifications.

## 11.4 Trademarks

Notice: All referenced brands, product names, service names and trademarks are the property of their respective owners.

## 12. Contact information

For more information, please visit: <http://www.nxp.com>

For sales office addresses, please send an email to: [salesaddresses@nxp.com](mailto:salesaddresses@nxp.com)

## 13. Contents

---

<b>1</b>	<b>Product profile</b> . . . . .	<b>1</b>
1.1	General description . . . . .	1
1.2	Features and benefits . . . . .	1
1.3	Applications . . . . .	1
1.4	Quick reference data . . . . .	1
<b>2</b>	<b>Pinning information</b> . . . . .	<b>2</b>
<b>3</b>	<b>Ordering information</b> . . . . .	<b>2</b>
<b>4</b>	<b>Marking</b> . . . . .	<b>2</b>
<b>5</b>	<b>Limiting values</b> . . . . .	<b>3</b>
<b>6</b>	<b>Thermal characteristics</b> . . . . .	<b>3</b>
<b>7</b>	<b>Static characteristics</b> . . . . .	<b>4</b>
<b>8</b>	<b>Dynamic characteristics</b> . . . . .	<b>5</b>
<b>9</b>	<b>Package outline</b> . . . . .	<b>12</b>
<b>10</b>	<b>Revision history</b> . . . . .	<b>13</b>
<b>11</b>	<b>Legal information</b> . . . . .	<b>14</b>
11.1	Data sheet status . . . . .	14
11.2	Definitions . . . . .	14
11.3	Disclaimers . . . . .	14
11.4	Trademarks . . . . .	15
<b>12</b>	<b>Contact information</b> . . . . .	<b>15</b>
<b>13</b>	<b>Contents</b> . . . . .	<b>16</b>

---

Please be aware that important notices concerning this document and the product(s) described herein, have been included in section 'Legal information'.

© NXP B.V. 2011.

All rights reserved.

For more information, please visit: <http://www.nxp.com>

For sales office addresses, please send an email to: [salesaddresses@nxp.com](mailto:salesaddresses@nxp.com)

Date of release: 15 September 2011

Document identifier: BF545A\_BF545B\_BF545C