

# 74HC138; 74HCT138

3-to-8 line decoder/demultiplexer; inverting

Rev. 03 — 23 December 2005

Product data sheet

## 1. General description

---

The 74HC138; 74HCT138 is a high-speed Si-gate CMOS device and is pin compatible with Low-power Schottky TTL (LSTTL).

The 74HC138; 74HCT138 decoder accepts three binary weighted address inputs (A0, A1 and A2) and when enabled, provides 8 mutually exclusive active LOW outputs ( $\bar{Y}0$  to  $\bar{Y}7$ ).

The 74HC138; 74HCT138 features three enable inputs: two active LOW ( $\bar{E}1$  and  $\bar{E}2$ ) and one active HIGH (E3). Every output will be HIGH unless  $\bar{E}1$  and  $\bar{E}2$  are LOW and E3 is HIGH.

This multiple enable function allows easy parallel expansion of the 74HC138; 74HCT138 to a 1-of-32 (5 lines to 32 lines) decoder with just four 74HC138; 74HCT138 ICs and one inverter.

The 74HC138; 74HCT138 can be used as an eight output demultiplexer by using one of the active LOW enable inputs as the data input and the remaining enable inputs as strobes. Not used enable inputs must be permanently tied to their appropriate active HIGH- or LOW-state.

The 74HC138; 74HCT138 is identical to the 74HC238; 74HCT238 but has inverting outputs.

## 2. Features

---

- Demultiplexing capability
- Multiple input enable for easy expansion
- Complies with JEDEC standard no. 7A
- Ideal for memory chip select decoding
- Active LOW mutually exclusive outputs
- ESD protection:
  - ◆ HBM EIA/JESD22-A114-C exceeds 2000 V
  - ◆ MM EIA/JESD22-A115-A exceeds 200 V
- Specified from  $-40\text{ }^{\circ}\text{C}$  to  $+85\text{ }^{\circ}\text{C}$  and from  $-40\text{ }^{\circ}\text{C}$  to  $+125\text{ }^{\circ}\text{C}$

**PHILIPS**

### 3. Quick reference data

**Table 1: Quick reference data**
*GND = 0 V; T<sub>amb</sub> = 25 °C; t<sub>r</sub> = t<sub>f</sub> = 6 ns.*

Symbol	Parameter	Conditions	Min	Typ	Max	Unit
<b>74HC138</b>						
t <sub>PHL</sub> , t <sub>PLH</sub>	propagation delay An to $\bar{Y}_n$ E3 to $\bar{Y}_n$ $\bar{E}_n$ to $\bar{Y}_n$	V <sub>CC</sub> = 5 V; C <sub>L</sub> = 15 pF	-	12 14 14	-	ns
C <sub>i</sub>	input capacitance		-	3.5	-	pF
C <sub>PD</sub>	power dissipation capacitance	V <sub>I</sub> = GND to V <sub>CC</sub>	[1]	67	-	pF
<b>74HCT138</b>						
t <sub>PHL</sub> , t <sub>PLH</sub>	propagation delay An to $\bar{Y}_n$ E3 to $\bar{Y}_n$ $\bar{E}_n$ to $\bar{Y}_n$	V <sub>CC</sub> = 5 V; C <sub>L</sub> = 15 pF	-	17 19 19	-	ns
C <sub>i</sub>	input capacitance		-	3.5	-	pF
C <sub>PD</sub>	power dissipation capacitance	V <sub>I</sub> = GND to (V <sub>CC</sub> - 1.5 V)	[1]	67	-	pF

[1] C<sub>PD</sub> is used to determine the dynamic power dissipation (P<sub>D</sub> in μW).

P<sub>D</sub> = C<sub>PD</sub> × V<sub>CC</sub><sup>2</sup> × f<sub>i</sub> × N + Σ(C<sub>L</sub> × V<sub>CC</sub><sup>2</sup> × f<sub>o</sub>) where:

f<sub>i</sub> = input frequency in MHz;

f<sub>o</sub> = output frequency in MHz;

C<sub>L</sub> = output load capacitance in pF;

V<sub>CC</sub> = supply voltage in V;

N = number of inputs switching;

Σ(C<sub>L</sub> × V<sub>CC</sub><sup>2</sup> × f<sub>o</sub>) = sum of the outputs.

### 4. Ordering information

**Table 2: Ordering information**

Type number	Package			Version
	Temperature range	Name	Description	
<b>74HC138</b>				
74HC138N	-40 °C to +125 °C	DIP16	plastic dual in-line package; 16 leads (300 mil); long body	SOT38-1
74HC138D	-40 °C to +125 °C	SO16	plastic small outline package; 16 leads; body width 3.9 mm	SOT109-1
74HC138DB	-40 °C to +125 °C	SSOP16	plastic shrink small outline package; 16 leads; body width 5.3 mm	SOT338-1
74HC138PW	-40 °C to +125 °C	TSSOP16	plastic thin shrink small outline package; 16 leads; body width 4.4 mm	SOT403-1
74HC138BQ	-40 °C to +125 °C	DHVQFN16	plastic dual in-line compatible thermal enhanced very thin quad flat package; no leads; 16 terminals; body 2.5 × 3.5 × 0.85 mm	SOT763-1

Table 2: Ordering information ...continued

Type number	Package			Version
	Temperature range	Name	Description	
<b>74HCT138</b>				
74HCT138N	-40 °C to +125 °C	DIP16	plastic dual in-line package; 16 leads (300 mil); long body	SOT38-1
74 HCT138D	-40 °C to +125 °C	SO16	plastic small outline package; 16 leads; body width 3.9 mm	SOT109-1
74HCT138DB	-40 °C to +125 °C	SSOP16	plastic shrink small outline package; 16 leads; body width 5.3 mm	SOT338-1
74HCT138PW	-40 °C to +125 °C	TSSOP16	plastic thin shrink small outline package; 16 leads; body width 4.4 mm	SOT403-1
74HCT138BQ	-40 °C to +125 °C	DHVQFN16	plastic dual in-line compatible thermal enhanced very thin quad flat package; no leads; 16 terminals; body 2.5 × 3.5 × 0.85 mm	SOT763-1

## 5. Functional diagram

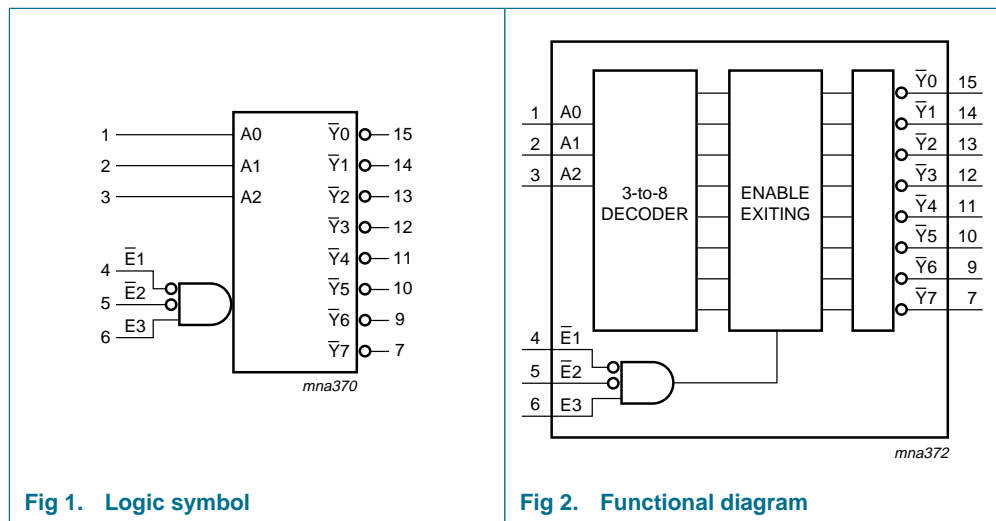

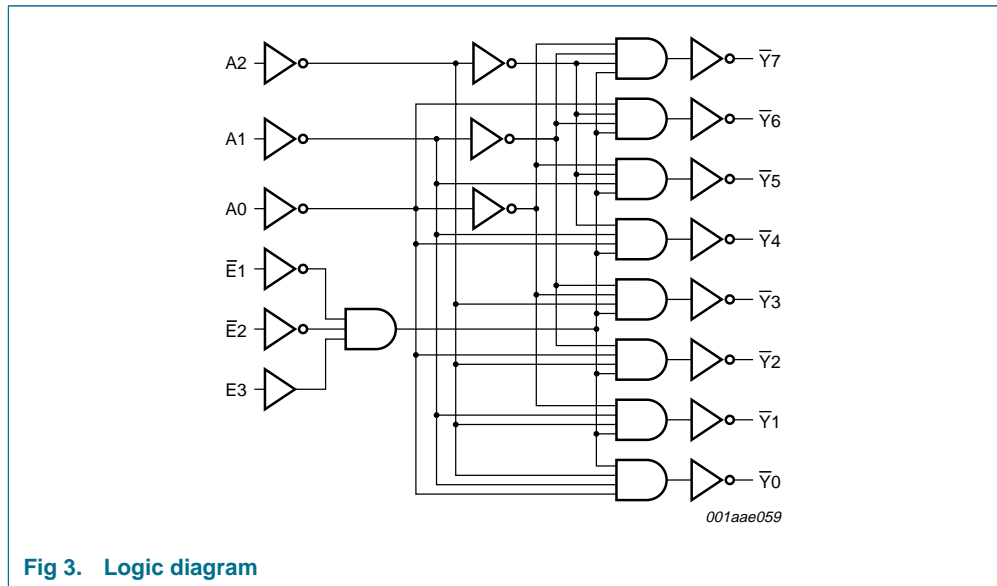

Fig 3. Logic diagram

## 6. Pinning information

### 6.1 Pinning

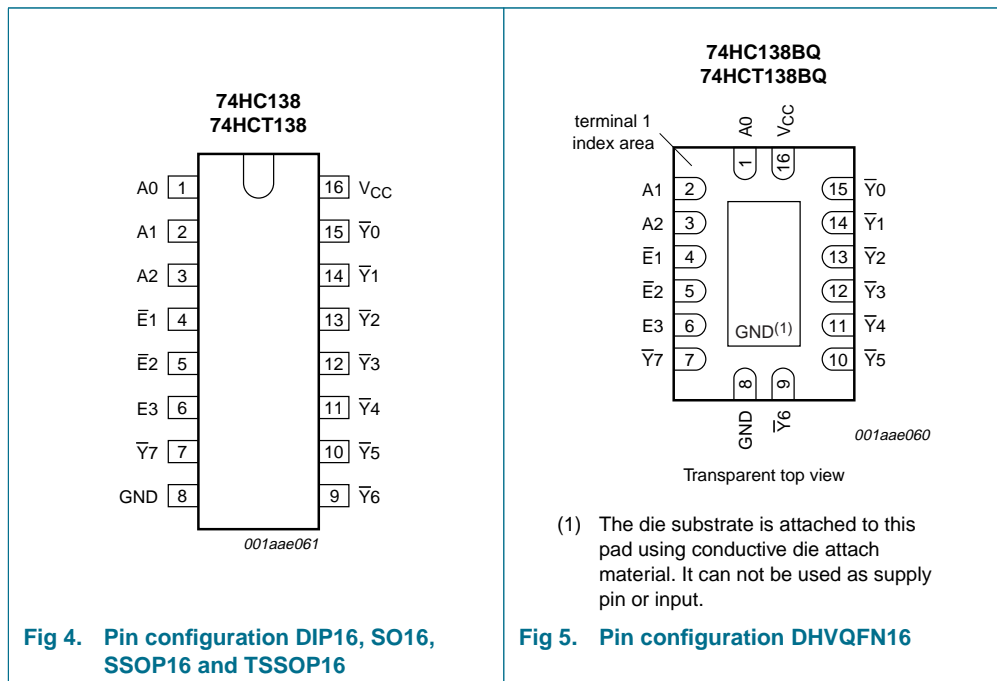

Fig 4. Pin configuration DIP16, SO16, SSOP16 and TSSOP16

Fig 5. Pin configuration DHVQFN16

## 6.2 Pin description

Table 3: Pin description

Symbol	Pin	Description
A0	1	address input 0
A1	2	address input 1
A2	3	address input 2
$\bar{E}1$	4	enable input 1 (active LOW)
$\bar{E}2$	5	enable input 2 (active LOW)
E3	6	enable input 3 (active HIGH)
$\bar{Y}7$	7	output 7 (active LOW)
GND	8	ground (0 V)
$\bar{Y}6$	9	output 6 (active LOW)
$\bar{Y}5$	10	output 5 (active LOW)
$\bar{Y}4$	11	output 4 (active LOW)
$\bar{Y}3$	12	output 3 (active LOW)
$\bar{Y}2$	13	output 2 (active LOW)
$\bar{Y}1$	14	output 1 (active LOW)
$\bar{Y}0$	15	output 0 (active LOW)
V <sub>CC</sub>	16	positive supply voltage

## 7. Functional description

Table 4: Function table [1]

Control			Input			Output							
$\bar{E}1$	$\bar{E}2$	E3	A2	A1	A0	$\bar{Y}7$	$\bar{Y}6$	$\bar{Y}5$	$\bar{Y}4$	$\bar{Y}3$	$\bar{Y}2$	$\bar{Y}1$	$\bar{Y}0$
H	X	X	X	X	X	H	H	H	H	H	H	H	H
X	H	X											
X	X	L											
L	L	H	L	L	L	H	H	H	H	H	H	H	L
			L	L	H	H	H	H	H	H	H	L	H
			L	H	L	H	H	H	H	H	L	H	H
			L	H	H	H	H	H	H	L	H	H	H
			H	L	L	H	H	H	L	H	H	H	H
			H	L	H	H	H	L	H	H	H	H	H
			H	H	L	H	L	H	H	H	H	H	H
			H	H	H	L	H	H	H	H	H	H	H

[1] H = HIGH voltage level;  
L = LOW voltage level;  
X = don't care.

## 8. Limiting values

**Table 5: Limiting values**

In accordance with the Absolute Maximum Rating System (IEC 60134). Voltages are referenced to GND (ground = 0 V).

Symbol	Parameter	Conditions	Min	Max	Unit
$V_{CC}$	supply voltage		-0.5	+7	V
$I_{IK}$	input clamping current	$V_I < -0.5\text{ V}$ or $V_I > V_{CC} + 0.5\text{ V}$	-	$\pm 20$	mA
$I_{OK}$	output clamping current	$V_O < -0.5\text{ V}$ or $V_O > V_{CC} + 0.5\text{ V}$	-	$\pm 20$	mA
$I_O$	output current	$V_O = -0.5\text{ V}$ to $(V_{CC} + 0.5\text{ V})$	-	$\pm 25$	mA
$I_{CC}$	quiescent supply current		-	50	mA
$I_{GND}$	ground current		-	-50	mA
$T_{stg}$	storage temperature		-65	+150	°C
$P_{tot}$	total power dissipation				
	DIP16 package		[1]	-	750 mW
	SO16 package		[2]	-	500 mW
	SSOP16 package		[3]	-	500 mW
	TSSOP16 package		[3]	-	500 mW
	DHVQFN16 package		[4]	-	500 mW

[1] For DIP16 package:  $P_{tot}$  derates linearly with 12 mW/K above 70 °C.

[2] For SO16 package:  $P_{tot}$  derates linearly with 8 mW/K above 70 °C.

[3] For SSOP16 and TSSOP16 packages:  $P_{tot}$  derates linearly with 5.5 mW/K above 60 °C.

[4] For DHVQFN16 packages:  $P_{tot}$  derates linearly with 4.5 mW/K above 60 °C.

## 9. Recommended operating conditions

**Table 6: Recommended operating conditions**

Symbol	Parameter	Conditions	Min	Typ	Max	Unit
<b>74HC138</b>						
$V_{CC}$	supply voltage		2.0	5.0	6.0	V
$V_I$	input voltage		0	-	$V_{CC}$	V
$V_O$	output voltage		0	-	$V_{CC}$	V
$T_{amb}$	ambient temperature		-40	+25	+125	°C
$t_r, t_f$	input rise and fall time	$V_{CC} = 2.0\text{ V}$	-	-	1000	ns
		$V_{CC} = 4.5\text{ V}$	-	6.0	500	ns
		$V_{CC} = 6.0\text{ V}$	-	-	400	ns
<b>74HCT138</b>						
$V_{CC}$	supply voltage		4.5	5.0	5.5	V
$V_I$	input voltage		0	-	$V_{CC}$	V
$V_O$	output voltage		0	-	$V_{CC}$	V
$T_{amb}$	ambient temperature		-40	+25	+125	°C
$t_r, t_f$	input rise and fall time	$V_{CC} = 4.5\text{ V}$	-	6.0	500	ns

## 10. Static characteristics

Table 7: Static characteristics 74HC138

At recommended operating conditions; voltages are referenced to GND (ground = 0 V).

Symbol	Parameter	Conditions	Min	Typ	Max	Unit
<b>T<sub>amb</sub> = 25 °C</b>						
V <sub>IH</sub>	HIGH-state input voltage	V <sub>CC</sub> = 2.0 V	1.5	1.2	-	V
		V <sub>CC</sub> = 4.5 V	3.15	2.4	-	V
		V <sub>CC</sub> = 6.0 V	4.2	3.2	-	V
V <sub>IL</sub>	LOW-state input voltage	V <sub>CC</sub> = 2.0 V	-	0.8	0.5	V
		V <sub>CC</sub> = 4.5 V	-	2.1	1.35	V
		V <sub>CC</sub> = 6.0 V	-	2.8	1.8	V
V <sub>OH</sub>	HIGH-state output voltage	V <sub>I</sub> = V <sub>IH</sub> or V <sub>IL</sub>				
		I <sub>O</sub> = -20 µA; V <sub>CC</sub> = 2.0 V	1.9	2.0	-	V
		I <sub>O</sub> = -20 µA; V <sub>CC</sub> = 4.5 V	4.4	4.5	-	V
		I <sub>O</sub> = -20 µA; V <sub>CC</sub> = 6.0 V	5.9	6.0	-	V
		I <sub>O</sub> = -4.0 mA; V <sub>CC</sub> = 4.5 V	3.98	4.32	-	V
V <sub>OL</sub>	LOW-state output voltage	V <sub>I</sub> = V <sub>IH</sub> or V <sub>IL</sub>				
		I <sub>O</sub> = 20 µA; V <sub>CC</sub> = 2.0 V	-	0	0.1	V
		I <sub>O</sub> = 20 µA; V <sub>CC</sub> = 4.5 V	-	0	0.1	V
		I <sub>O</sub> = 20 µA; V <sub>CC</sub> = 6.0 V	-	0	0.1	V
		I <sub>O</sub> = 4.0 mA; V <sub>CC</sub> = 4.5 V	-	0.15	0.26	V
I <sub>LI</sub>	input leakage current	V <sub>I</sub> = V <sub>CC</sub> or GND; V <sub>CC</sub> = 6 V	-	-	±0.1	µA
I <sub>OZ</sub>	OFF-state output current	V <sub>I</sub> = V <sub>IH</sub> or V <sub>IL</sub> ; V <sub>O</sub> = V <sub>CC</sub> or GND; V <sub>CC</sub> = 6.0 V			±0.5	µA
I <sub>CC</sub>	quiescent supply current	V <sub>CC</sub> = 6.0 V; I <sub>O</sub> = 0 A; V <sub>I</sub> = V <sub>CC</sub> or GND	-	-	8.0	µA
C <sub>i</sub>	input capacitance		-	3.5	-	pF
<b>T<sub>amb</sub> = -40 °C to +85 °C</b>						
V <sub>IH</sub>	HIGH-state input voltage	V <sub>CC</sub> = 2.0 V	1.5	-	-	V
		V <sub>CC</sub> = 4.5 V	3.15	-	-	V
		V <sub>CC</sub> = 6.0 V	4.2	-	-	V
V <sub>IL</sub>	LOW-state input voltage	V <sub>CC</sub> = 2.0 V	-	-	0.5	V
		V <sub>CC</sub> = 4.5 V	-	-	1.35	V
		V <sub>CC</sub> = 6.0 V	-	-	1.8	V
V <sub>OH</sub>	HIGH-state output voltage	V <sub>I</sub> = V <sub>IH</sub> or V <sub>IL</sub>				
		I <sub>O</sub> = -20 µA; V <sub>CC</sub> = 2.0 V	1.9	-	-	V
		I <sub>O</sub> = -20 µA; V <sub>CC</sub> = 4.5 V	4.4	-	-	V
		I <sub>O</sub> = -20 µA; V <sub>CC</sub> = 6.0 V	5.9	-	-	V
		I <sub>O</sub> = -4.0 mA; V <sub>CC</sub> = 4.5 V	3.84	-	-	V
	I <sub>O</sub> = -5.2 mA; V <sub>CC</sub> = 6 V	5.34	-	-	V	

Table 7: Static characteristics 74HC138 ...continued

At recommended operating conditions; voltages are referenced to GND (ground = 0 V).

Symbol	Parameter	Conditions	Min	Typ	Max	Unit
V <sub>OL</sub>	LOW-state output voltage	V <sub>I</sub> = V <sub>IH</sub> or V <sub>IL</sub>				
		I <sub>O</sub> = 20 μA; V <sub>CC</sub> = 2.0 V	-	-	0.1	V
		I <sub>O</sub> = 20 μA; V <sub>CC</sub> = 4.5 V	-	-	0.1	V
		I <sub>O</sub> = 20 μA; V <sub>CC</sub> = 6.0 V	-	-	0.1	V
		I <sub>O</sub> = 4.0 mA; V <sub>CC</sub> = 4.5 V	-	-	0.33	V
		I <sub>O</sub> = 5.2 mA; V <sub>CC</sub> = 6 V	-	-	0.33	V
I <sub>LI</sub>	input leakage current	V <sub>I</sub> = V <sub>CC</sub> or GND; V <sub>CC</sub> = 6 V	-	-	±1.0	μA
I <sub>OZ</sub>	OFF-state output current	V <sub>I</sub> = V <sub>IH</sub> or V <sub>IL</sub> ; V <sub>O</sub> = V <sub>CC</sub> or GND; V <sub>CC</sub> = 6.0 V			±5.0	μA
I <sub>CC</sub>	quiescent supply current	V <sub>CC</sub> = 6.0 V; I <sub>O</sub> = 0 A; V <sub>I</sub> = V <sub>CC</sub> or GND	-	-	80	μA
<b>T<sub>amb</sub> = -40 °C to +125 °C</b>						
V <sub>IH</sub>	HIGH-state input voltage	V <sub>CC</sub> = 2.0 V	1.5	-	-	V
		V <sub>CC</sub> = 4.5 V	3.15	-	-	V
		V <sub>CC</sub> = 6.0 V	4.2	-	-	V
V <sub>IL</sub>	LOW-state input voltage	V <sub>CC</sub> = 2.0 V	-	-	0.5	V
		V <sub>CC</sub> = 4.5 V	-	-	1.35	V
		V <sub>CC</sub> = 6.0 V	-	-	1.8	V
V <sub>OH</sub>	HIGH-state output voltage	V <sub>I</sub> = V <sub>IH</sub> or V <sub>IL</sub>				
		I <sub>O</sub> = -20 μA; V <sub>CC</sub> = 2.0 V	1.9	-	-	V
		I <sub>O</sub> = -20 μA; V <sub>CC</sub> = 4.5 V	4.4	-	-	V
		I <sub>O</sub> = -20 μA; V <sub>CC</sub> = 6.0 V	5.9	-	-	V
		I <sub>O</sub> = -4.0 mA; V <sub>CC</sub> = 4.5 V	3.7	-	-	V
		I <sub>O</sub> = -5.2 mA; V <sub>CC</sub> = 6 V	5.2	-	-	V
V <sub>OL</sub>	LOW-state output voltage	V <sub>I</sub> = V <sub>IH</sub> or V <sub>IL</sub>				
		I <sub>O</sub> = 20 μA; V <sub>CC</sub> = 2.0 V	-	-	0.1	V
		I <sub>O</sub> = 20 μA; V <sub>CC</sub> = 4.5 V	-	-	0.1	V
		I <sub>O</sub> = 20 μA; V <sub>CC</sub> = 6.0 V	-	-	0.1	V
		I <sub>O</sub> = 4.0 mA; V <sub>CC</sub> = 4.5 V	-	-	0.4	V
		I <sub>O</sub> = 5.2 mA; V <sub>CC</sub> = 6 V	-	-	0.4	V
I <sub>LI</sub>	input leakage current	V <sub>I</sub> = V <sub>CC</sub> or GND; V <sub>CC</sub> = 6 V	-	-	±1.0	μA
I <sub>OZ</sub>	OFF-state output current	V <sub>I</sub> = V <sub>IH</sub> or V <sub>IL</sub> ; V <sub>O</sub> = V <sub>CC</sub> or GND; V <sub>CC</sub> = 6.0 V			±10.0	μA
I <sub>CC</sub>	quiescent supply current	V <sub>CC</sub> = 6.0 V; I <sub>O</sub> = 0 A; V <sub>I</sub> = V <sub>CC</sub> or GND	-	-	160	μA



**Table 8: Static characteristics 74HCT138**

At recommended operating conditions; voltages are referenced to GND (ground = 0 V).

Symbol	Parameter	Conditions	Min	Typ	Max	Unit
<b>T<sub>amb</sub> = 25 °C</b>						
V <sub>IH</sub>	HIGH-state input voltage	V <sub>CC</sub> = 4.5 V to 5.5 V	2.0	1.6	-	V
V <sub>IL</sub>	LOW-state input voltage	V <sub>CC</sub> = 4.5 V to 5.5 V	-	1.2	0.8	V
V <sub>OH</sub>	HIGH-state output voltage	V <sub>I</sub> = V <sub>IH</sub> or V <sub>IL</sub>				
		I <sub>O</sub> = -20 µA; V <sub>CC</sub> = 4.5 V	4.4	4.5	-	V
		I <sub>O</sub> = -4.0 mA; V <sub>CC</sub> = 4.5 V	3.98	4.32	-	V
V <sub>OL</sub>	LOW-state output voltage	V <sub>I</sub> = V <sub>IH</sub> or V <sub>IL</sub>				
		I <sub>O</sub> = 20 µA; V <sub>CC</sub> = 4.5 V	-	0.0	0.1	V
		I <sub>O</sub> = 4.0 mA; V <sub>CC</sub> = 4.5 V	-	0.15	0.26	V
I <sub>LI</sub>	input leakage current	V <sub>I</sub> = V <sub>CC</sub> or GND; V <sub>CC</sub> = 5.5 V	-	-	±0.1	µA
I <sub>OZ</sub>	OFF-state output current	V <sub>I</sub> = V <sub>IH</sub> or V <sub>IL</sub> ; V <sub>CC</sub> = 5.5 V; V <sub>O</sub> = V <sub>CC</sub> or GND; I <sub>O</sub> = 0 A	-	-	±0.5	µA
I <sub>CC</sub>	quiescent supply current	V <sub>CC</sub> = 6.0 V; I <sub>O</sub> = 0 A; V <sub>I</sub> = V <sub>CC</sub> or GND	-	-	8.0	µA
ΔI <sub>CC</sub>	additional quiescent supply current	per input pin; V <sub>I</sub> = V <sub>CC</sub> - 2.1 V; other inputs at V <sub>CC</sub> or GND; V <sub>CC</sub> = 4.5 V to 5.5 V; I <sub>O</sub> = 0 A				
		pin An	-	150	540	µA
		pin $\bar{E}n$	-	125	450	µA
		pin E3	-	100	360	µA
C <sub>i</sub>	input capacitance		-	3.5	-	pF
<b>T<sub>amb</sub> = -40 °C to +85 °C</b>						
V <sub>IH</sub>	HIGH-state input voltage	V <sub>CC</sub> = 4.5 to 5.5 V	2.0	-	-	V
V <sub>IL</sub>	LOW-state input voltage	V <sub>CC</sub> = 4.5 to 5.5 V	-	-	0.8	V
V <sub>OH</sub>	HIGH-state output voltage	V <sub>I</sub> = V <sub>IH</sub> or V <sub>IL</sub>				
		I <sub>O</sub> = -20 µA; V <sub>CC</sub> = 4.5 V	4.4	-	-	V
		I <sub>O</sub> = -4.0 mA; V <sub>CC</sub> = 4.5 V	3.84	-	-	V
V <sub>OL</sub>	LOW-state output voltage	V <sub>I</sub> = V <sub>IH</sub> or V <sub>IL</sub>				
		I <sub>O</sub> = 20 µA; V <sub>CC</sub> = 4.5 V	-	-	0.1	V
		I <sub>O</sub> = 4.0 mA; V <sub>CC</sub> = 4.5 V	-	-	0.33	V
I <sub>LI</sub>	input leakage current	V <sub>I</sub> = V <sub>CC</sub> or GND; V <sub>CC</sub> = 5.5 V	-	-	±1.0	µA
I <sub>OZ</sub>	OFF-state output current	V <sub>I</sub> = V <sub>IH</sub> or V <sub>IL</sub> ; V <sub>CC</sub> = 5.5 V; V <sub>O</sub> = V <sub>CC</sub> or GND; I <sub>O</sub> = 0 A	-	-	±5.0	µA
I <sub>CC</sub>	quiescent supply current	V <sub>CC</sub> = 5.5 V; I <sub>O</sub> = 0 A; V <sub>I</sub> = V <sub>CC</sub> or GND	-	-	80	µA
ΔI <sub>CC</sub>	additional quiescent supply current	per input pin; V <sub>I</sub> = V <sub>CC</sub> - 2.1 V; other inputs at V <sub>CC</sub> or GND; V <sub>CC</sub> = 4.5 V to 5.5 V; I <sub>O</sub> = 0 A				
		pin An	-	-	675	µA
		pin $\bar{E}n$	-	-	562.5	µA
		pin E3	-	-	450	µA

**Table 8: Static characteristics 74HCT138 ...continued**

At recommended operating conditions; voltages are referenced to GND (ground = 0 V).

Symbol	Parameter	Conditions	Min	Typ	Max	Unit	
<b>T<sub>amb</sub> = -40 °C to +125 °C</b>							
V <sub>IH</sub>	HIGH-state input voltage	V <sub>CC</sub> = 4.5 V to 5.5 V	2.0	-	-	V	
V <sub>IL</sub>	LOW-state input voltage	V <sub>CC</sub> = 4.5 V to 5.5 V	-	-	0.8	V	
V <sub>OH</sub>	HIGH-state output voltage	V <sub>I</sub> = V <sub>IH</sub> or V <sub>IL</sub>					
		I <sub>O</sub> = -20 μA; V <sub>CC</sub> = 4.5 V	4.4	-	-	V	
		I <sub>O</sub> = -4.0 mA; V <sub>CC</sub> = 4.5 V	3.7	-	-	V	
V <sub>OL</sub>	LOW-state output voltage	V <sub>I</sub> = V <sub>IH</sub> or V <sub>IL</sub>					
		I <sub>O</sub> = 20 μA; V <sub>CC</sub> = 4.5 V	-	-	0.1	V	
		I <sub>O</sub> = 4.0 mA; V <sub>CC</sub> = 4.5 V	-	-	0.4	V	
I <sub>LI</sub>	input leakage current	V <sub>I</sub> = V <sub>CC</sub> or GND; V <sub>CC</sub> = 5.5 V	-	-	1.0	μA	
I <sub>OZ</sub>	OFF-state output current	V <sub>I</sub> = V <sub>IH</sub> or V <sub>IL</sub> ; V <sub>CC</sub> = 5.5 V; V <sub>O</sub> = V <sub>CC</sub> or GND; I <sub>O</sub> = 0 A	-	-	±10.0	μA	
I <sub>CC</sub>	quiescent supply current	V <sub>CC</sub> = 5.5 V; I <sub>O</sub> = 0 A; V <sub>I</sub> = V <sub>CC</sub> or GND	-	-	160	μA	
ΔI <sub>CC</sub>	additional quiescent supply current	per input pin; V <sub>I</sub> = V <sub>CC</sub> - 2.1 V; other inputs at V <sub>CC</sub> or GND; V <sub>CC</sub> = 4.5 V to 5.5 V; I <sub>O</sub> = 0 A					
			pin An	-	-	735	μA
			pin $\bar{E}n$	-	-	612.5	μA
			pin E3	-	-	490	μA

## 11. Dynamic characteristics

**Table 9: Dynamic characteristics 74HC138**

Voltages are referenced to GND (ground = 0 V);  $C_L = 50$  pF unless otherwise specified.

For test circuit see [Figure 8](#).

Symbol	Parameter	Conditions	Min	Typ	Max	Unit
<b><math>T_{amb} = 25</math> °C</b>						
$t_{PHL}$ , $t_{PLH}$	propagation delay					
	An to $\bar{Y}_n$	see <a href="#">Figure 6</a>				
		$V_{CC} = 2.0$ V	-	41	150	ns
		$V_{CC} = 4.5$ V	-	15	30	ns
		$V_{CC} = 5$ V; $C_L = 15$ pF	-	12	-	ns
		$V_{CC} = 6.0$ V	-	12	26	ns
	E3 to $\bar{Y}_n$	see <a href="#">Figure 6</a>				
		$V_{CC} = 2.0$ V	-	47	150	ns
		$V_{CC} = 4.5$ V	-	17	30	ns
		$V_{CC} = 5$ V; $C_L = 15$ pF	-	14	-	ns
		$V_{CC} = 6.0$ V	-	14	26	ns
	$\bar{E}_n$ to $\bar{Y}_n$	see <a href="#">Figure 7</a>				
		$V_{CC} = 2.0$ V	-	47	150	ns
		$V_{CC} = 4.5$ V	-	17	30	ns
		$V_{CC} = 5$ V; $C_L = 15$ pF	-	14	-	ns
		$V_{CC} = 6.0$ V	-	14	26	ns
$t_{THL}$ , $t_{TLH}$	output transition time	see <a href="#">Figure 6</a> and <a href="#">7</a>				
		$V_{CC} = 2.0$ V	-	19	75	ns
		$V_{CC} = 4.5$ V	-	7	15	ns
		$V_{CC} = 6.0$ V	-	6	13	ns
$C_{PD}$	power dissipation capacitance	$V_I = \text{GND to } V_{CC}$	<a href="#">[1]</a>	-	67	pF
<b><math>T_{amb} = -40</math> °C to <math>+85</math> °C</b>						
$t_{PHL}$ , $t_{PLH}$	propagation delay					
	An to $\bar{Y}_n$	see <a href="#">Figure 6</a>				
		$V_{CC} = 2.0$ V	-	-	190	ns
		$V_{CC} = 4.5$ V	-	-	38	ns
		$V_{CC} = 6.0$ V	-	-	33	ns
	E3 to $\bar{Y}_n$	see <a href="#">Figure 6</a>				
		$V_{CC} = 2.0$ V	-	-	190	ns
		$V_{CC} = 4.5$ V	-	-	38	ns
		$V_{CC} = 6.0$ V	-	-	33	ns
	$\bar{E}_n$ to $\bar{Y}_n$	see <a href="#">Figure 7</a>				
		$V_{CC} = 2.0$ V	-	-	190	ns
		$V_{CC} = 4.5$ V	-	-	38	ns
		$V_{CC} = 6.0$ V	-	-	33	ns

**Table 9: Dynamic characteristics 74HC138 ...continued**

Voltages are referenced to GND (ground = 0 V);  $C_L = 50$  pF unless otherwise specified.

For test circuit see [Figure 8](#).

Symbol	Parameter	Conditions	Min	Typ	Max	Unit
$t_{THL}$ , $t_{TLH}$	output transition time	see <a href="#">Figure 6</a> and <a href="#">7</a>				
		$V_{CC} = 2.0$ V	-	-	95	ns
		$V_{CC} = 4.5$ V	-	-	19	ns
		$V_{CC} = 6.0$ V	-	-	16	ns
<b><math>T_{amb} = -40</math> °C to <math>+125</math> °C</b>						
$t_{PHL}$ , $t_{PLH}$	propagation delay					
	$A_n$ to $\bar{Y}_n$	see <a href="#">Figure 6</a>				
		$V_{CC} = 2.0$ V	-	-	225	ns
		$V_{CC} = 4.5$ V	-	-	45	ns
		$V_{CC} = 6.0$ V	-	-	38	ns
	$E_3$ to $\bar{Y}_n$	see <a href="#">Figure 6</a>				
		$V_{CC} = 2.0$ V	-	-	225	ns
		$V_{CC} = 4.5$ V	-	-	45	ns
		$V_{CC} = 6.0$ V	-	-	38	ns
	$\bar{E}_n$ to $\bar{Y}_n$	see <a href="#">Figure 7</a>				
		$V_{CC} = 2.0$ V	-	-	225	ns
		$V_{CC} = 4.5$ V	-	-	45	ns
		$V_{CC} = 6.0$ V	-	-	38	ns
$t_{THL}$ , $t_{TLH}$	output transition time	see <a href="#">Figure 6</a> and <a href="#">7</a>				
		$V_{CC} = 2.0$ V	-	-	110	ns
		$V_{CC} = 4.5$ V	-	-	22	ns
		$V_{CC} = 6.0$ V	-	-	19	ns

[1]  $C_{PD}$  is used to determine the dynamic power dissipation ( $P_D$  in  $\mu$ W).

$$P_D = C_{PD} \times V_{CC}^2 \times f_i \times N + \Sigma(C_L \times V_{CC}^2 \times f_o) \text{ where:}$$

$f_i$  = input frequency in MHz;

$f_o$  = output frequency in MHz;

$C_L$  = output load capacitance in pF;

$V_{CC}$  = supply voltage in V;

$N$  = number of inputs switching;

$\Sigma(C_L \times V_{CC}^2 \times f_o)$  = sum of the outputs.

**Table 10: Dynamic characteristics 74HCT138**

Voltages are referenced to GND (ground = 0 V);  $C_L = 50$  pF unless otherwise specified.

For test circuit see [Figure 8](#).

Symbol	Parameter	Conditions	Min	Typ	Max	Unit
<b><math>T_{amb} = 25</math> °C</b>						
$t_{PHL}$ , $t_{PLH}$	propagation delay					
	An to $\bar{Y}_n$	see <a href="#">Figure 6</a>				
		$V_{CC} = 4.5$ V	-	20	35	ns
		$V_{CC} = 5$ V; $C_L = 15$ pF	-	17	-	ns
	E3 to $\bar{Y}_n$	see <a href="#">Figure 6</a>				
		$V_{CC} = 4.5$ V	-	18	40	ns
		$V_{CC} = 5$ V; $C_L = 15$ pF	-	19	-	ns
	$\bar{E}_n$ to $\bar{Y}_n$	see <a href="#">Figure 7</a>				
		$V_{CC} = 4.5$ V	-	19	40	ns
		$V_{CC} = 5$ V; $C_L = 15$ pF	-	19	-	ns
$t_{THL}$ , $t_{TLH}$	output transition time	see <a href="#">Figure 6</a> and <a href="#">7</a>				
		$V_{CC} = 4.5$ V	-	7	15	ns
$C_{PD}$	power dissipation capacitance	$V_I = \text{GND to } (V_{CC} - 1.5 \text{ V})$ <a href="#">[1]</a>	-	67	-	pF
<b><math>T_{amb} = -40</math> °C to <math>+85</math> °C</b>						
$t_{PHL}$ , $t_{PLH}$	propagation delay					
	An to $\bar{Y}_n$	see <a href="#">Figure 6</a>				
		$V_{CC} = 4.5$ V	-	-	44	ns
	E3 to $\bar{Y}_n$	see <a href="#">Figure 6</a>				
		$V_{CC} = 4.5$ V	-	-	50	ns
	$\bar{E}_n$ to $\bar{Y}_n$	see <a href="#">Figure 7</a>				
		$V_{CC} = 4.5$ V	-	-	50	ns
$t_{THL}$ , $t_{TLH}$	output transition time	see <a href="#">Figure 6</a> and <a href="#">7</a>				
		$V_{CC} = 4.5$ V	-	-	19	ns
<b><math>T_{amb} = -40</math> °C to <math>+125</math> °C</b>						
$t_{PHL}$ , $t_{PLH}$	propagation delay					
	An to $\bar{Y}_n$	see <a href="#">Figure 6</a>				
		$V_{CC} = 4.5$ V	-	-	53	ns
	E3 to $\bar{Y}_n$	see <a href="#">Figure 6</a>				
		$V_{CC} = 4.5$ V	-	-	60	ns
	$\bar{E}_n$ to $\bar{Y}_n$	see <a href="#">Figure 7</a>				
		$V_{CC} = 4.5$ V	-	-	60	ns
$t_{THL}$ , $t_{TLH}$	output transition time	see <a href="#">Figure 6</a> and <a href="#">7</a>				
		$V_{CC} = 4.5$ V	-	-	22	ns

[1]  $C_{PD}$  is used to determine the dynamic power dissipation ( $P_D$  in  $\mu\text{W}$ ).

$P_D = C_{PD} \times V_{CC}^2 \times f_i \times N + \Sigma(C_L \times V_{CC}^2 \times f_o)$  where:

$f_i$  = input frequency in MHz;

$f_o$  = output frequency in MHz;

$C_L$  = output load capacitance in pF;

$V_{CC}$  = supply voltage in V;  
 N = number of inputs switching;  
 $\Sigma(C_L \times V_{CC}^2 \times f_o)$  = sum of the outputs.

## 12. Waveforms

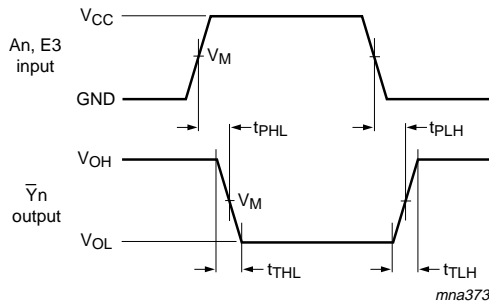

Measurement points are given in [Table 11](#).

$V_{OL}$  and  $V_{OH}$  are typical voltage output drop that occur with the output load.

**Fig 6. Propagation delay input (An) and enable input (E3) to output ( $\bar{Y}_n$ ) and transition time output ( $\bar{Y}_n$ )**

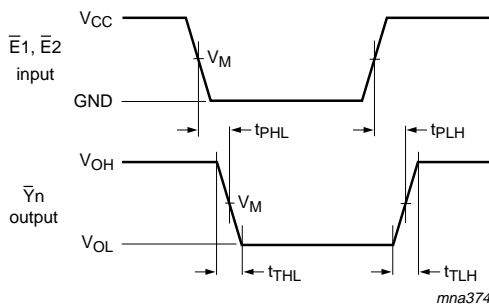

Measurement points are given in [Table 11](#).

$V_{OL}$  and  $V_{OH}$  are typical voltage output drop that occur with the output load.

**Fig 7. Propagation delay enable input ( $\bar{E}_n$ ) to output ( $\bar{Y}_n$ ) and transition time output ( $\bar{Y}_n$ )**

**Table 11: Measurement points**

Type	Input	Output
	$V_M$	$V_M$
74HC138	$0.5V_{CC}$	$0.5V_{CC}$
74HCT138	1.3 V	1.3 V

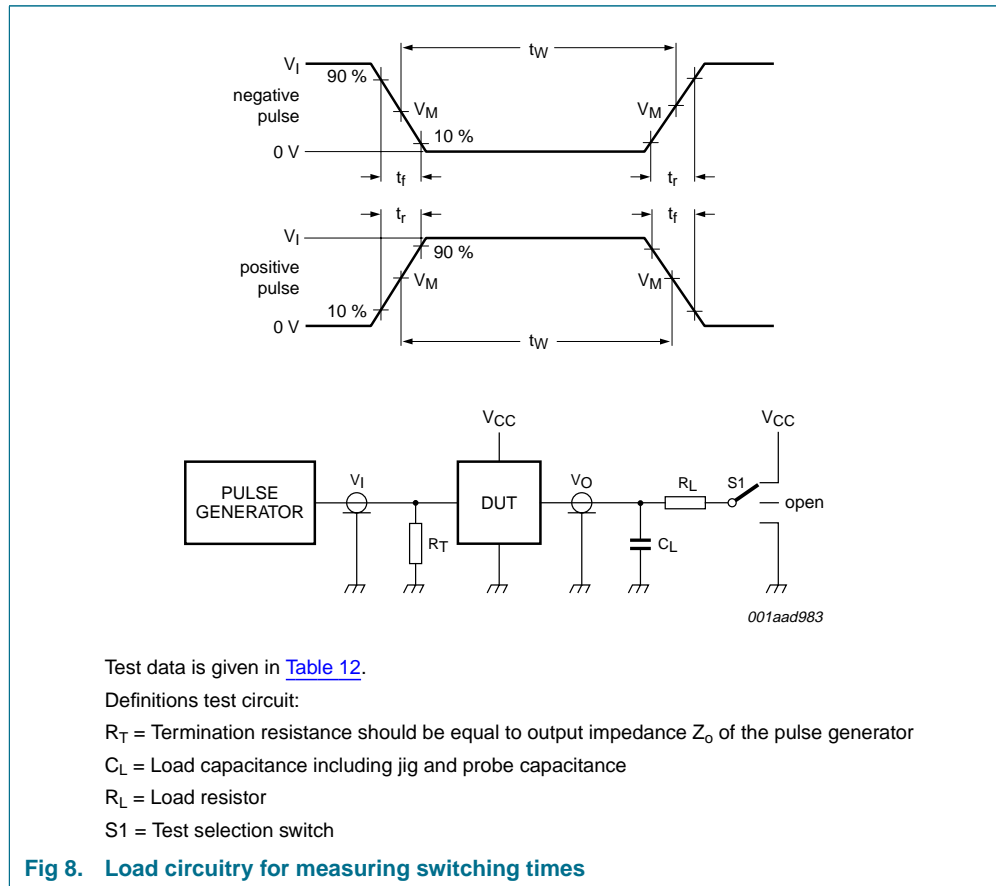

**Table 12: Test data**

Type	Input		Load		S1 position		
	$V_I$	$t_r, t_f$	$C_L$	$R_L$	$t_{PHL}, t_{PLH}$	$t_{PZH}, t_{PHZ}$	$t_{PZL}, t_{PLZ}$
74HC138	$V_{CC}$	6 ns	15 pF, 50 pF	1 k $\Omega$	open	GND	$V_{CC}$
74HCT138	3 V	6 ns	15 pF, 50 pF	1 k $\Omega$	open	GND	$V_{CC}$

13. Package outline

DIP16: plastic dual in-line package; 16 leads (300 mil); long body

SOT38-1

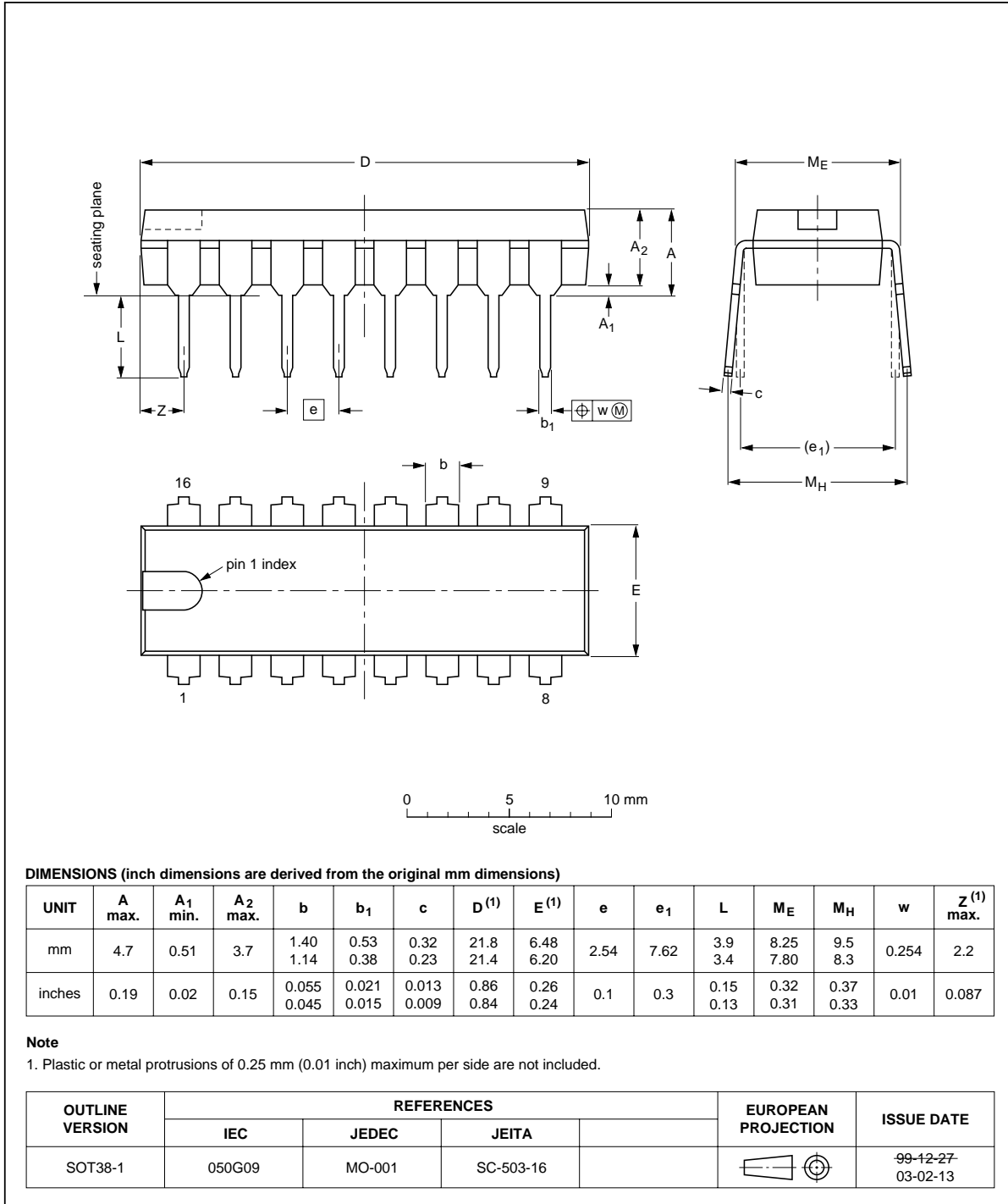

Fig 9. Package outline SOT38-1 (DIP16)



SO16: plastic small outline package; 16 leads; body width 3.9 mm

SOT109-1

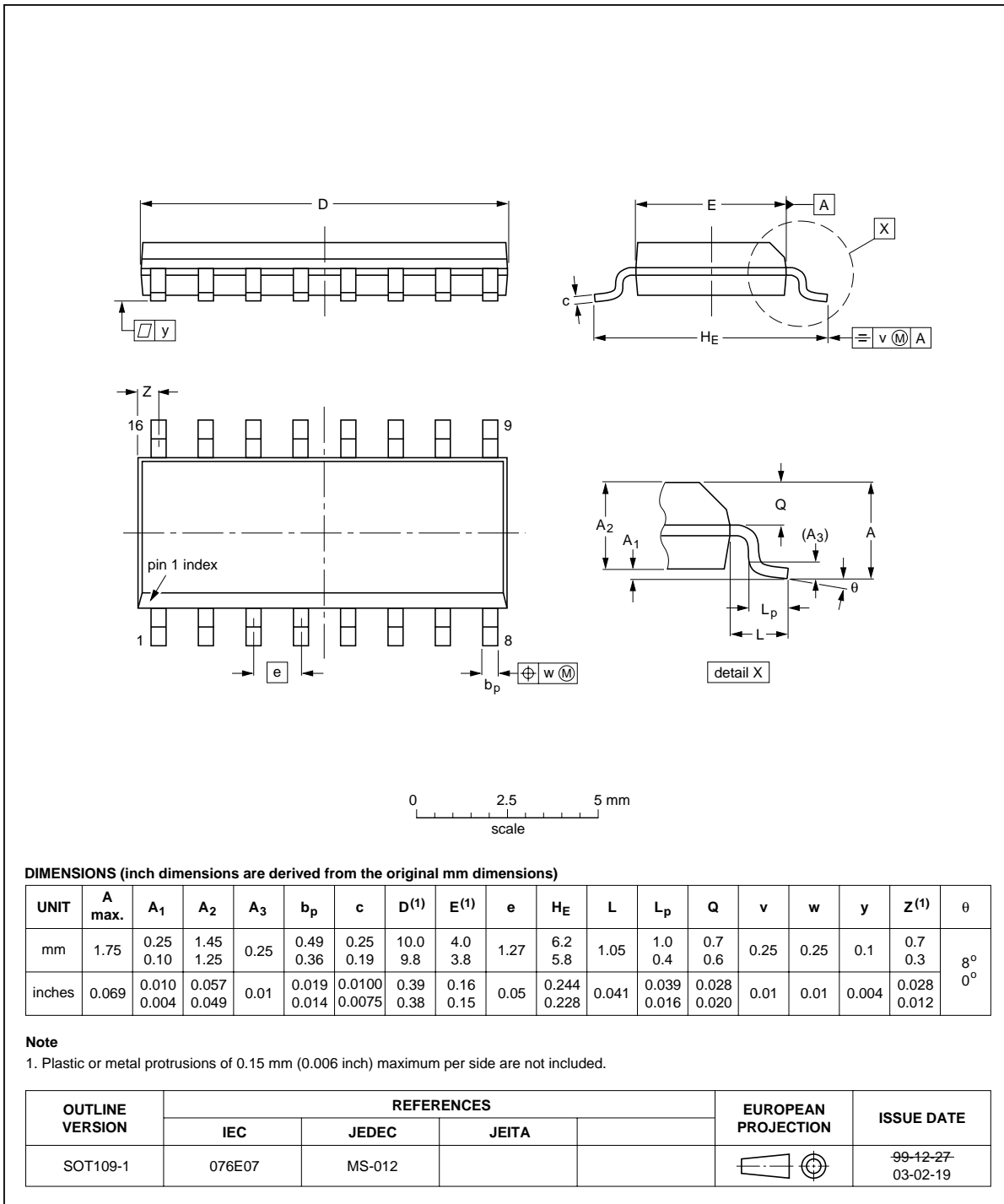

Fig 10. Package outline SOT109-1 (SO16)

TSSOP16: plastic thin shrink small outline package; 16 leads; body width 4.4 mm

SOT403-1

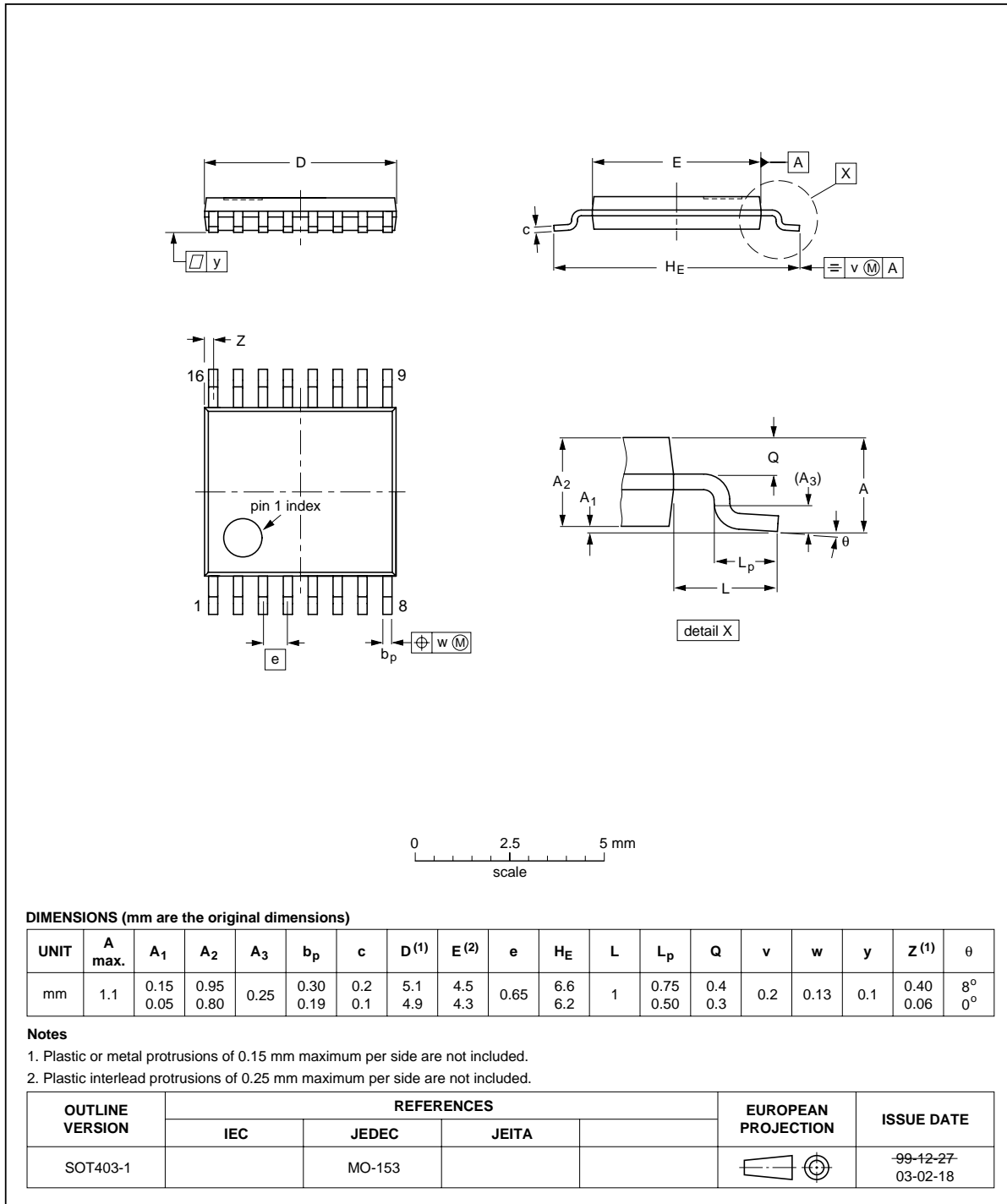

Fig 11. Package outline SOT403-1 (TSSOP16)

SSOP16: plastic shrink small outline package; 16 leads; body width 5.3 mm

SOT338-1

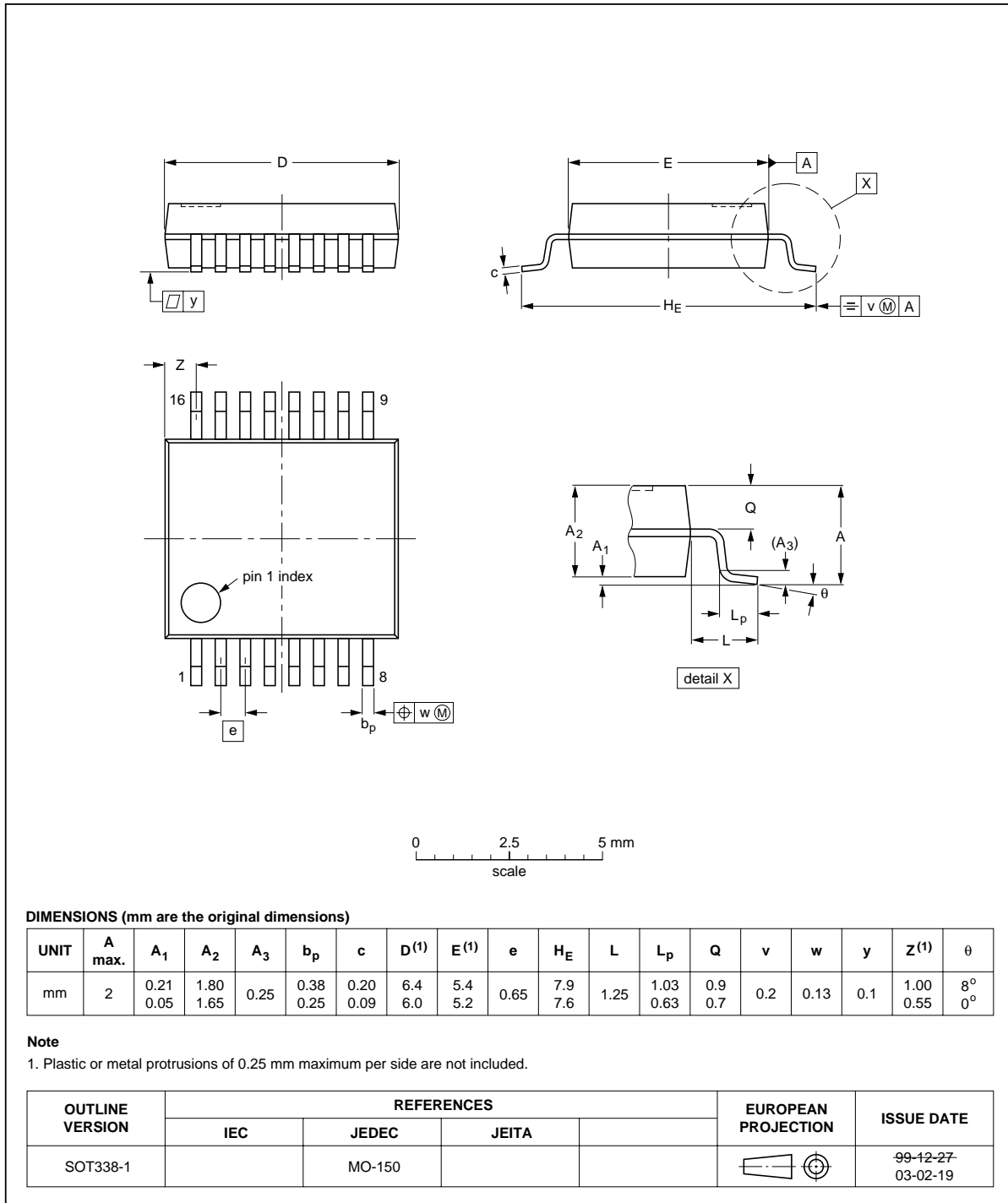

Fig 12. Package outline SOT338-1 (SSOP16)

DHVQFN16: plastic dual in-line compatible thermal enhanced very thin quad flat package; no leads; 16 terminals; body 2.5 x 3.5 x 0.85 mm SOT763-1

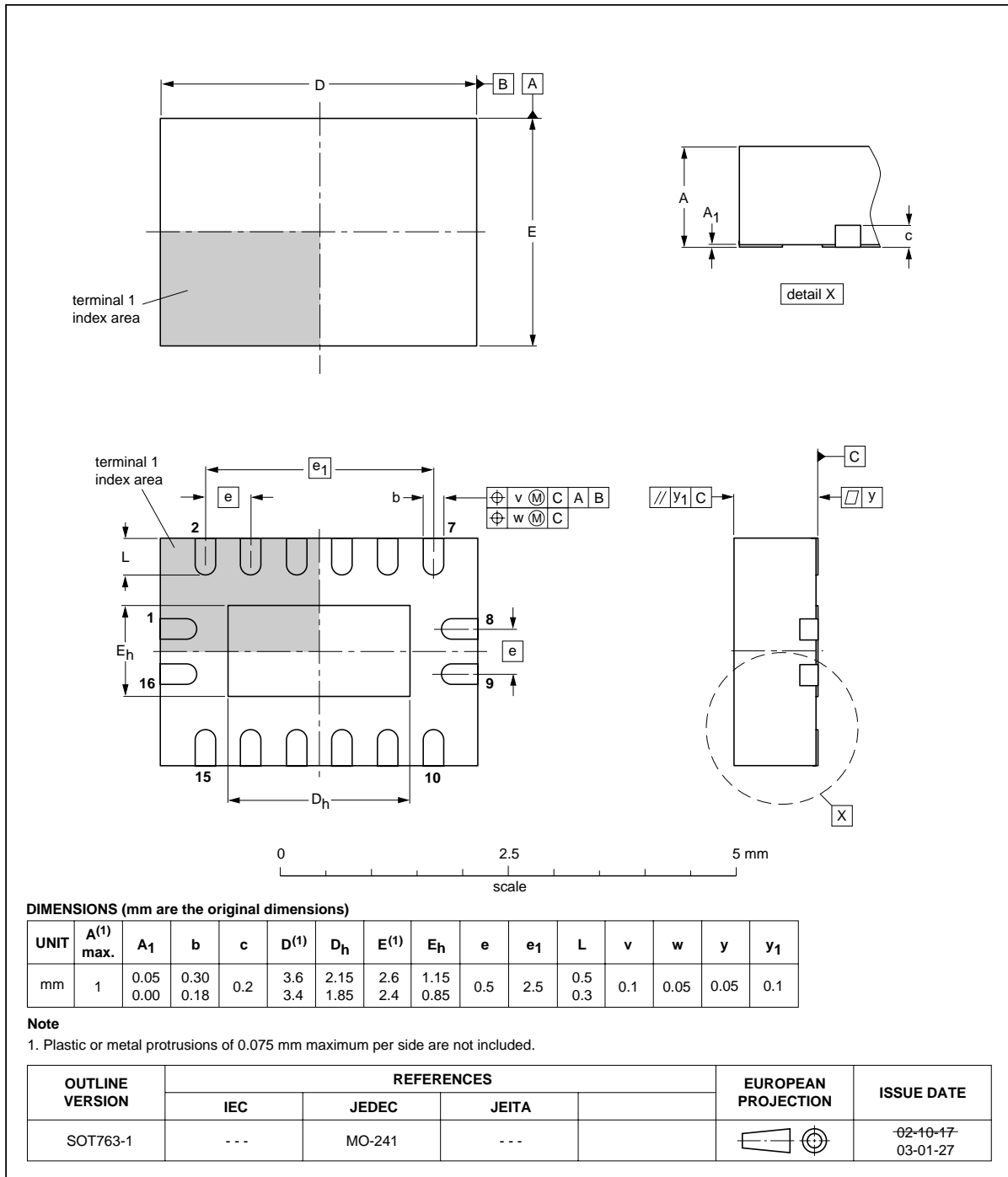

Fig 13. Package outline SOT763-1 (DHVQFN16)

## 14. Abbreviations

Table 13: Abbreviations

Acronym	Description
CMOS	Complementary Metal Oxide Semiconductor
DUT	Device Under Test
ESD	ElectroStatic Discharge
HBM	Human Body Model
LSTTL	Low-power Schottky Transistor-Transistor Logic
MM	Machine Model

## 15. Revision history

Table 14: Revision history

Document ID	Release date	Data sheet status	Change notice	Doc. number	Supersedes
74HC_HCT138_3	20051223	Product data sheet	-	-	74HC_HCT138_CNV_2
Modifications:					<ul style="list-style-type: none"> <li>The format of this data sheet has been redesigned to comply with the new presentation and information standard of Philips Semiconductors.</li> <li><a href="#">Section 4 "Ordering information"</a>, <a href="#">Section 6 "Pinning information"</a> and <a href="#">Section 13 "Package outline"</a>: Added DHVQFN package information</li> <li><a href="#">Section 10 "Static characteristics"</a>: Added from the family specification</li> </ul>
74HC_HCT138_CNV_2	19970827	Product specification	-	-	-

## 16. Data sheet status

Level	Data sheet status [1]	Product status [2] [3]	Definition
I	Objective data	Development	This data sheet contains data from the objective specification for product development. Philips Semiconductors reserves the right to change the specification in any manner without notice.
II	Preliminary data	Qualification	This data sheet contains data from the preliminary specification. Supplementary data will be published at a later date. Philips Semiconductors reserves the right to change the specification without notice, in order to improve the design and supply the best possible product.
III	Product data	Production	This data sheet contains data from the product specification. Philips Semiconductors reserves the right to make changes at any time in order to improve the design, manufacturing and supply. Relevant changes will be communicated via a Customer Product/Process Change Notification (CPCN).

[1] Please consult the most recently issued data sheet before initiating or completing a design.

[2] The product status of the device(s) described in this data sheet may have changed since this data sheet was published. The latest information is available on the Internet at URL <http://www.semiconductors.philips.com>.

[3] For data sheets describing multiple type numbers, the highest-level product status determines the data sheet status.

## 17. Definitions

**Short-form specification** — The data in a short-form specification is extracted from a full data sheet with the same type number and title. For detailed information see the relevant data sheet or data handbook.

**Limiting values definition** — Limiting values given are in accordance with the Absolute Maximum Rating System (IEC 60134). Stress above one or more of the limiting values may cause permanent damage to the device. These are stress ratings only and operation of the device at these or at any other conditions above those given in the Characteristics sections of the specification is not implied. Exposure to limiting values for extended periods may affect device reliability.

**Application information** — Applications that are described herein for any of these products are for illustrative purposes only. Philips Semiconductors makes no representation or warranty that such applications will be suitable for the specified use without further testing or modification.

## 18. Disclaimers

**Life support** — These products are not designed for use in life support appliances, devices, or systems where malfunction of these products can reasonably be expected to result in personal injury. Philips Semiconductors

customers using or selling these products for use in such applications do so at their own risk and agree to fully indemnify Philips Semiconductors for any damages resulting from such application.

**Right to make changes** — Philips Semiconductors reserves the right to make changes in the products - including circuits, standard cells, and/or software - described or contained herein in order to improve design and/or performance. When the product is in full production (status 'Production'), relevant changes will be communicated via a Customer Product/Process Change Notification (CPCN). Philips Semiconductors assumes no responsibility or liability for the use of any of these products, conveys no license or title under any patent, copyright, or mask work right to these products, and makes no representations or warranties that these products are free from patent, copyright, or mask work right infringement, unless otherwise specified.

## 19. Trademarks

**Notice** — All referenced brands, product names, service names and trademarks are the property of their respective owners.

## 20. Contact information

For additional information, please visit: <http://www.semiconductors.philips.com>

For sales office addresses, send an email to: [sales.addresses@www.semiconductors.philips.com](mailto:sales.addresses@www.semiconductors.philips.com)



## 21. Contents

---

1	General description . . . . .	1
2	Features . . . . .	1
3	Quick reference data . . . . .	2
4	Ordering information . . . . .	2
5	Functional diagram . . . . .	3
6	Pinning information . . . . .	4
6.1	Pinning . . . . .	4
6.2	Pin description . . . . .	5
7	Functional description . . . . .	5
8	Limiting values . . . . .	6
9	Recommended operating conditions . . . . .	6
10	Static characteristics . . . . .	7
11	Dynamic characteristics . . . . .	11
12	Waveforms . . . . .	14
13	Package outline . . . . .	16
14	Abbreviations . . . . .	21
15	Revision history . . . . .	21
16	Data sheet status . . . . .	22
17	Definitions . . . . .	22
18	Disclaimers . . . . .	22
19	Trademarks . . . . .	22
20	Contact information . . . . .	22



© Koninklijke Philips Electronics N.V. 2005

All rights are reserved. Reproduction in whole or in part is prohibited without the prior written consent of the copyright owner. The information presented in this document does not form part of any quotation or contract, is believed to be accurate and reliable and may be changed without notice. No liability will be accepted by the publisher for any consequence of its use. Publication thereof does not convey nor imply any license under patent- or other industrial or intellectual property rights.

Date of release: 23 December 2005  
Document number: 74HC\_HCT138\_3

Published in The Netherlands