

74ALVT16374

16-bit edge-triggered D-type flip-flop; 3-state

Rev. 04 — 4 July 2005

Product data sheet

1. General description

The 74ALVT16374 is a high performance BiCMOS product designed for V_{CC} operation at 2.5 V or 3.3 V with I/O compatibility up to 5 V.

This device is a 16-bit edge-triggered D-type flip-flop featuring non-inverting 3-state outputs. The device can be used as two 8-bit flip-flops or one 16-bit flip-flop. On the positive transition of the clock (CP), the Q outputs of the flip-flop take on the logic levels set up at the D inputs.

2. Features

- 16-bit edge-triggered flip-flop
- 5 V I/O compatible
- 3-state buffers
- Output capability: +64 mA and -32 mA
- TTL input and output switching levels
- Input and output interface capability to systems at 5 V supply
- Bus-hold data inputs eliminate the need for external pull-up resistors to hold unused inputs
- Live insertion and extraction permitted
- Power-up reset
- Power-up 3-state
- No bus current loading when output is tied to 5 V bus
- Latch-up protection exceeds 500 mA per JESD78
- Electrostatic discharge protection:
 - ◆ MIL STD 883 method 3015: exceeds 2000 V
 - ◆ Machine model: exceeds 200 V

PHILIPS

3. Quick reference data

Table 1: Quick reference data

$T_{amb} = 25\text{ }^{\circ}\text{C}$.

Symbol	Parameter	Conditions	Min	Typ	Max	Unit
$V_{CC} = 2.5\text{ V}$						
t_{PLH}	propagation delay nCP to nQx	$C_L = 50\text{ pF}$	-	2.6	-	ns
t_{PHL}	propagation delay nCP to nQx	$C_L = 50\text{ pF}$	-	2.8	-	ns
C_i	input capacitance nCP and n \overline{OE}	$V_I = 0\text{ V or }V_{CC}$	-	3	-	pF
C_o	output capacitance	outputs disabled; $V_O = 0\text{ V or }V_{CC}$	-	9	-	pF
I_{CC}	supply current	outputs disabled	-	40	-	μA
$V_{CC} = 3.3\text{ V}$						
t_{PLH}	propagation delay nCP to nQx	$C_L = 50\text{ pF}$	-	2.1	-	ns
t_{PHL}	propagation delay nCP to nQx	$C_L = 50\text{ pF}$	-	2.3	-	ns
C_i	input capacitance nCP and n \overline{OE}	$V_I = 0\text{ V or }V_{CC}$	-	3	-	pF
C_o	output capacitance	outputs disabled; $V_O = 0\text{ V or }V_{CC}$	-	9	-	pF
I_{CC}	supply current	outputs disabled	-	40	-	μA

4. Ordering information

Table 2: Ordering information

Type number	Package			Version
	Temperature range	Name	Description	
74ALVT16374DGG	-40 °C to +85 °C	TSSOP48	plastic thin shrink small outline package; 48 leads; body width 6.1 mm	SOT362-1
74ALVT16374DL	-40 °C to +85 °C	SSOP48	plastic shrink small outline package; 48 leads; body width 7.5 mm	SOT370-1

5. Functional diagram

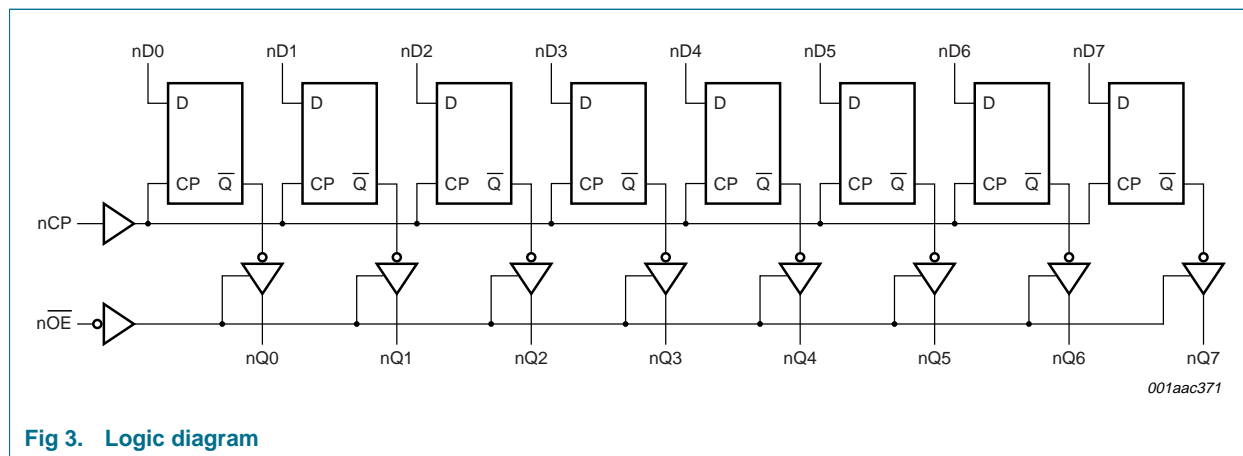
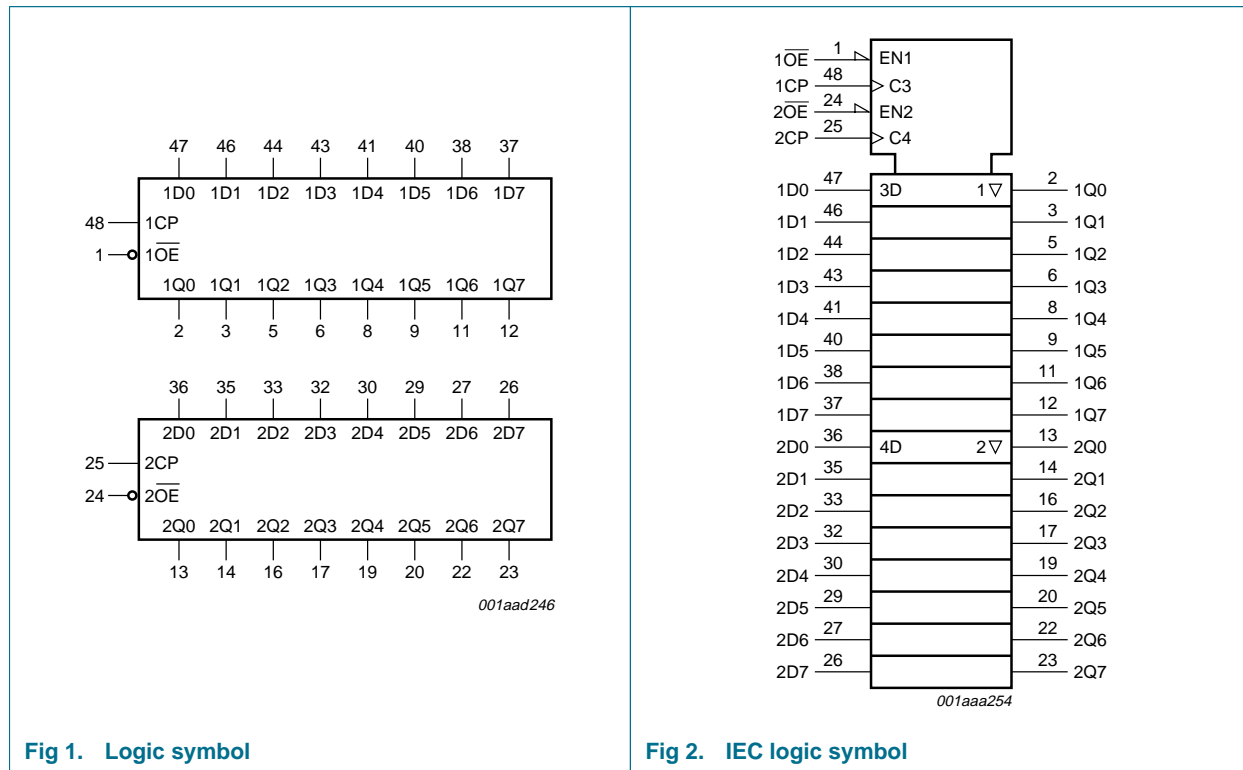

6. Pinning information

6.1 Pinning

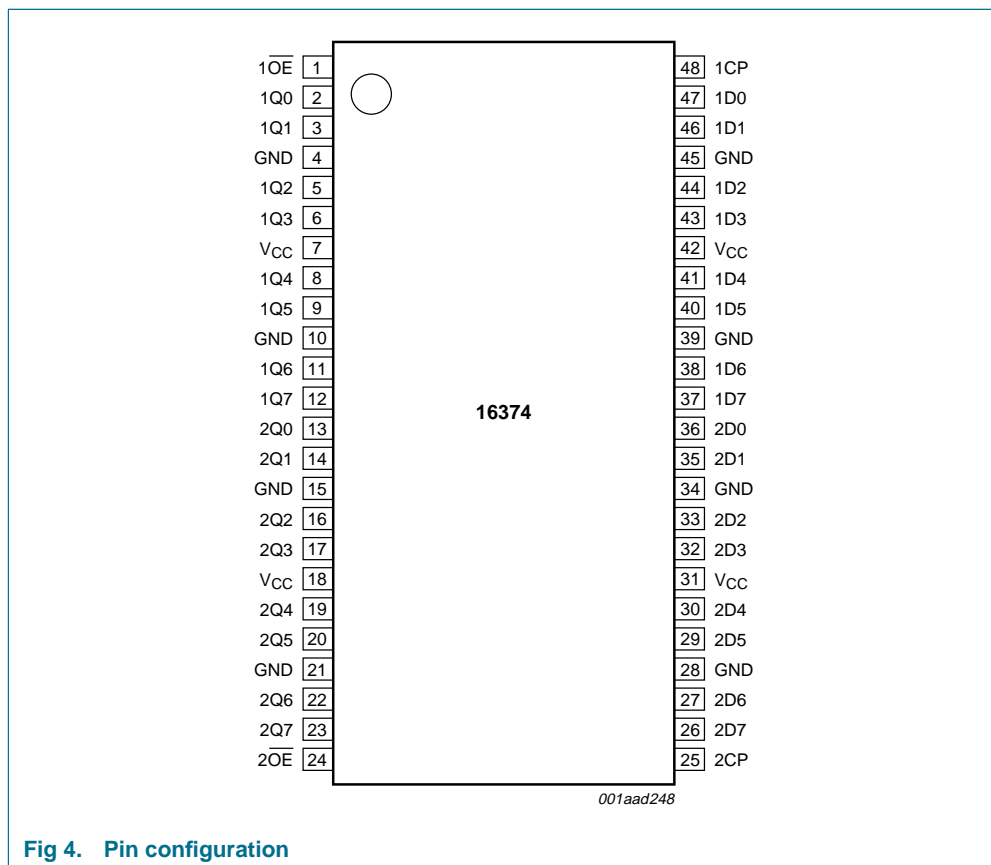

6.2 Pin description

Table 3: Pin description

Symbol	Pin	Description
1OE	1	output enable input (active LOW)
1Q0	2	data output
1Q1	3	data output
GND	4	ground (0 V)
1Q2	5	data output
1Q3	6	data output
V _{CC}	7	supply voltage
1Q4	8	data output
1Q5	9	data output
GND	10	ground (0 V)
1Q6	11	data output

Table 3: Pin description

Symbol	Pin	Description
1Q7	12	data output
2Q0	13	data output
2Q1	14	data output
GND	15	ground (0 V)
2Q2	16	data output
2Q3	17	data output
V _{CC}	18	supply voltage
2Q4	19	data output
2Q5	20	data output
GND	21	ground (0 V)
2Q6	22	data output
2Q7	23	data output
2 \overline{OE}	24	output enable input (active LOW)
2CP	25	clock pulse input (active rising edge)
2D7	26	data input
2D6	27	data input
GND	28	ground (0 V)
2D5	29	data input
2D4	30	data input
V _{CC}	31	supply voltage
2D3	32	data input
2D2	33	data input
GND	34	ground (0 V)
2D1	35	data input
2D0	36	data input
1D7	37	data input
1D6	38	data input
GND	39	ground (0 V)
1D5	40	data input
1D4	41	data input
V _{CC}	42	supply voltage
1D3	43	data input
1D2	44	data input
GND	45	ground (0 V)
1D1	46	data input
1D0	47	data input
1CP	48	clock pulse input (active rising edge)

7. Functional description

7.1 Function table

Table 4: Function table [1]

Input			Internal register	Output	Operating mode
nOE	nCP	nDx		nQx	
L	↑	l	L	L	load and read register
L	↑	h	H	H	
L	NC	X	NC	NC	hold
H	NC	X	NC	Z	disable outputs
H	↑	nDx	nDx	Z	

- [1] H = HIGH voltage level;
 h = HIGH voltage level one setup time prior to the HIGH-to-LOW clock transition;
 L = LOW voltage level;
 l = LOW voltage level one setup time prior to the HIGH-to-LOW clock transition;
 NC = no change;
 X = don't care;
 Z = high-impedance OFF-state;
 ↑ = LOW-to-HIGH clock transition.

8. Limiting values

Table 5: Limiting values

In accordance with the Absolute Maximum Rating System (IEC 60134). Voltages are referenced to GND (ground = 0 V)

Symbol	Parameter	Conditions	Min	Max	Unit
V _{CC}	supply voltage		-0.5	+4.6	V
V _I	input voltage		[1] -0.5	+7.0	V
V _O	output voltage	output in OFF-state or HIGH-state	[1] -0.5	+7.0	V
I _{IK}	input diode current	V _I < 0 V	-	-50	mA
I _{OK}	output diode current	V _O < 0 V	-	-50	mA
I _O	output current	output in LOW-state	-	128	mA
		output in HIGH-state	-	-64	mA
T _{stg}	storage temperature		-65	+150	°C
T _j	junction temperature		[2] -	150	°C

- [1] The input and output negative voltage ratings may be exceeded if the input and output clamp current ratings are observed.
- [2] The performance capability of a high-performance integrated circuit in conjunction with its thermal environment can create junction temperatures which are detrimental to reliability.

9. Recommended operating conditions

Table 6: Recommended operating conditions

Symbol	Parameter	Conditions	Min	Typ	Max	Unit
$V_{CC} = 2.5\text{ V} \pm 0.2\text{ V}$						
V_{CC}	supply voltage		2.3	-	2.7	V
V_I	input voltage		0	-	5.5	V
V_{IH}	HIGH-level input voltage		1.7	-	-	V
V_{IL}	LOW-level input voltage		-	-	0.7	V
I_{OH}	HIGH-level output current		-	-	-8	mA
I_{OL}	LOW-level output current	none	-	-	8	mA
		duty cycle < 50 %; $f \geq 1\text{ kHz}$	-	-	24	mA
$\Delta t/\Delta V$	input transition rise or fall rate	outputs enabled	-	-	10	ns/V
T_{amb}	ambient temperature		-40	-	+85	°C
$V_{CC} = 3.3\text{ V} \pm 0.3\text{ V}$						
V_{CC}	supply voltage		3.0	-	3.6	V
V_I	input voltage		0	-	5.5	V
V_{IH}	HIGH-level input voltage		2.0	-	-	V
V_{IL}	LOW-level input voltage		-	-	0.8	V
I_{OH}	HIGH-level output current		-	-	-32	mA
I_{OL}	LOW-level output current	none	-	-	32	mA
		duty cycle < 50 %; $f \geq 1\text{ kHz}$	-	-	64	mA
$\Delta t/\Delta V$	input transition rise or fall rate	outputs enabled	-	-	10	ns/V
T_{amb}	ambient temperature		-40	-	+85	°C

10. Static characteristics

Table 7: Static characteristics

At recommended operating conditions; voltages are referenced to GND (ground = 0 V).

$T_{amb} = -40\text{ °C}$ to $+85\text{ °C}$.

Symbol	Parameter	Conditions	Min	Typ	Max	Unit
$V_{CC} = 2.5\text{ V} \pm 0.2\text{ V}$ [1]						
V_{IK}	input diode voltage	$V_{CC} = 2.3\text{ V}$; $I_{IK} = -18\text{ mA}$	-	-0.85	-1.2	V
V_{OH}	HIGH-level output voltage	$V_{CC} = 2.3\text{ V}$ to 3.6 V ; $I_{OH} = -100\text{ }\mu\text{A}$	$V_{CC} - 0.2$	V_{CC}	-	V
		$V_{CC} = 2.3\text{ V}$; $I_{OH} = -8\text{ mA}$	1.8	2.1	-	V
V_{OL}	LOW-level output voltage	$V_{CC} = 2.3\text{ V}$; $I_{OL} = 100\text{ }\mu\text{A}$	-	0.07	0.2	V
		$V_{CC} = 2.3\text{ V}$; $I_{OL} = 24\text{ mA}$	-	0.3	0.5	V
V_{RST}	power-up LOW-state output voltage	$V_{CC} = 2.7\text{ V}$; $I_O = 1\text{ mA}$; $V_I = V_{CC}$ or GND	[2] -	-	0.55	V

Table 7: Static characteristics ...continued

At recommended operating conditions; voltages are referenced to GND (ground = 0 V).

 $T_{amb} = -40\text{ }^{\circ}\text{C}$ to $+85\text{ }^{\circ}\text{C}$.

Symbol	Parameter	Conditions	Min	Typ	Max	Unit		
I_{LI}	input leakage current	control pins	$V_{CC} = 2.7\text{ V}; V_I = V_{CC}$ or GND	-	0.1	± 1	μA	
			$V_{CC} = 0\text{ V}$ or $2.7\text{ V}; V_I = 5.5\text{ V}$	-	0.1	10	μA	
	I/O data pins		$V_{CC} = 2.7\text{ V}; V_I = V_{CC}$	[3]	-	0.1	1	μA
			$V_{CC} = 2.7\text{ V}; V_I = 0\text{ V}$	[3]	-	+0.1	-5	μA
I_{OFF}	output power-down current	$V_{CC} = 0\text{ V}; V_I$ or $V_O = 0\text{ V}$ to 4.5 V	-	0.1	± 100	μA		
I_{HOLD}	bus hold current D inputs		$V_{CC} = 2.3\text{ V}; V_I = 0.7\text{ V}$	[4] [5]	-	90	-	μA
			$V_{CC} = 2.3\text{ V}; V_I = 1.7\text{ V}$	[4] [5]	-	-10	-	μA
I_{EX}	external current into output	output in HIGH-state when $V_O > V_{CC}; V_O = 5.5\text{ V}; V_{CC} = 2.3\text{ V}$	-	10	125	μA		
I_{PU}	power-up 3-state output current	$V_{CC} \leq 1.2\text{ V}; V_O = 0.5\text{ V}$ to $V_{CC}; V_I = \text{GND}$ or $V_{CC}; \text{nOE} = \text{don't care}$	[6]	-	1	100	μA	
I_{PD}	power-down 3-state output current	$V_{CC} \leq 1.2\text{ V}; V_O = 0.5\text{ V}$ to $V_{CC}; V_I = \text{GND}$ or $V_{CC}; \text{nOE} = \text{don't care}$	[6]	-	1	100	μA	
I_{OZ}	3-state OFF-state output current	$V_{CC} = 2.7\text{ V}; V_I = V_{IH}$ or V_{IL}						
		output HIGH; $V_O = 2.3\text{ V}$	-	0.5	5	μA		
		output LOW; $V_O = 0.5\text{ V}$	-	+0.5	-5	μA		
I_{CC}	supply current	$V_{CC} = 2.7\text{ V}; V_I = V_{CC}$ or GND; $I_O = 0\text{ A}$						
		outputs HIGH-state	-	0.04	0.1	mA		
		outputs LOW-state	-	2.7	4.5	mA		
		outputs disabled	[7]	-	0.04	0.1	mA	
ΔI_{CC}	additional supply current per input pin	$V_{CC} = 2.3\text{ V}$ to 2.7 V ; one input at $V_{CC} - 0.6\text{ V}$; other inputs at V_{CC} or GND	[8]	-	0.04	0.4	mA	
C_i	input capacitance nCP and nOE	$V_I = 0\text{ V}$ or V_{CC}	-	3	-	pF		
C_o	output capacitance	outputs disabled; $V_O = 0\text{ V}$ or V_{CC}	-	9	-	pF		
$V_{CC} = 3.3\text{ V} \pm 0.3\text{ V}$ [9]								
V_{IK}	input clamp voltage	$V_{CC} = 3.0\text{ V}; I_{IK} = -18\text{ mA}$	-	-0.85	-1.2	V		
V_{OH}	HIGH-level output voltage	$V_{CC} = 3.0\text{ V}$ to $3.6\text{ V}; I_{OH} = -100\text{ }\mu\text{A}$	$V_{CC} - 0.2$	V_{CC}	-	V		
		$V_{CC} = 3.0\text{ V}; I_{OH} = -32\text{ mA}$	2.0	2.3	-	V		
V_{OL}	LOW-level output voltage	$V_{CC} = 3.0\text{ V}; I_{OL} = 100\text{ }\mu\text{A}$	-	0.07	0.2	V		
		$V_{CC} = 3.0\text{ V}; I_{OL} = 16\text{ mA}$	-	0.25	0.4	V		
		$V_{CC} = 3.0\text{ V}; I_{OL} = 32\text{ mA}$	-	0.3	0.5	V		
		$V_{CC} = 3.0\text{ V}; I_{OL} = 64\text{ mA}$	-	0.4	0.55	V		
V_{RST}	power-up LOW-state output voltage	$V_{CC} = 3.6\text{ V}; I_O = 1\text{ mA}; V_I = V_{CC}$ or GND	[2]	-	0.55	V		

Table 7: Static characteristics ...continued

At recommended operating conditions; voltages are referenced to GND (ground = 0 V).

 $T_{amb} = -40\text{ }^{\circ}\text{C}$ to $+85\text{ }^{\circ}\text{C}$.

Symbol	Parameter	Conditions	Min	Typ	Max	Unit		
I_{LI}	input leakage current	control pins	$V_{CC} = 3.6\text{ V}; V_I = V_{CC}$ or GND	-	0.1	± 1	μA	
			$V_{CC} = 0\text{ V}$ or $3.6\text{ V}; V_I = 5.5\text{ V}$	-	0.1	10	μA	
	I/O data pins		$V_{CC} = 3.6\text{ V}; V_I = V_{CC}$	[3]	-	0.1	1	μA
			$V_{CC} = 3.6\text{ V}; V_I = 0\text{ V}$	[3]	-	0.1	-5	μA
I_{OFF}	output power-down current	$V_{CC} = 0\text{ V}; V_I$ or $V_O = 0\text{ V}$ to 4.5 V	-	0.1	± 100	μA		
I_{HOLD}	bus hold current D inputs		$V_{CC} = 3.0\text{ V}; V_I = 0.8\text{ V}$	[5]	75	130	-	μA
			$V_{CC} = 3.0\text{ V}; V_I = 2.0\text{ V}$	[5]	-75	-140	-	μA
			$V_{CC} = 0\text{ V}$ to $3.6\text{ V}; V_I = 3.6\text{ V}$	[5]	± 500	-	-	μA
I_{EX}	external current into output	output in HIGH-state when $V_O > V_{CC}; V_O = 5.5\text{ V}; V_{CC} = 3.0\text{ V}$	-	10	125	μA		
I_{PU}	power-up 3-state output current	$V_{CC} \leq 1.2\text{ V}; V_O = 0.5\text{ V}$ to $V_{CC}; V_I = V_{CC}$ or GND; $n\overline{OE} = \text{don't care}$	[10]	-	1	± 100	μA	
I_{PD}	power-down 3-state output current	$V_{CC} \leq 1.2\text{ V}; V_O = 0.5\text{ V}$ to $V_{CC}; V_I = V_{CC}$ or GND; $n\overline{OE} = \text{don't care}$	[10]	-	1	± 100	μA	
I_{OZ}	3-state OFF-state output current		$V_{CC} = 3.6\text{ V}; V_I = V_{IH}$ or V_{IL}					
		output HIGH; $V_O = 3.0\text{ V}$	-	0.5	5	μA		
		output LOW; $V_O = 0.5\text{ V}$	-	+0.5	-5	μA		
I_{CC}	supply current		$V_{CC} = 3.6\text{ V}; V_I = \text{GND}$ or $V_{CC}; I_O = 0\text{ A}$					
		outputs HIGH-state	-	0.04	0.1	mA		
		outputs LOW-state	-	3.7	6	mA		
		outputs disabled	[7]	-	0.04	0.1	mA	
ΔI_{CC}	additional supply current per input pin	$V_{CC} = 3.0\text{ V}$ to $3.6\text{ V};$ one input at $V_{CC} - 0.6\text{ V};$ other inputs at V_{CC} or GND	[8]	-	0.04	0.4	mA	
C_i	input capacitance nCP and $n\overline{OE}$	$V_I = 0\text{ V}$ or V_{CC}	-	3	-	pF		
C_o	output capacitance	outputs disabled; $V_O = 0\text{ V}$ or V_{CC}	-	9	-	pF		

[1] Typical values are at $V_{CC} = 2.5\text{ V}$ and $T_{amb} = 25\text{ }^{\circ}\text{C}$.

[2] For valid test results, data must not be loaded into the flip-flops (or latches) after applying power.

[3] Unused pins at V_{CC} or GND.

[4] Not guaranteed

[5] This is the bus-hold overdrive current required to force the input to the opposite logic state.

[6] This parameter is valid for any V_{CC} between 0 V and 1.2 V with a transition time of up to 10 ms . From $V_{CC} = 1.2\text{ V}$ to $V_{CC} = 2.5\text{ V} \pm 0.2\text{ V}$ a transition time of $100\text{ }\mu\text{s}$ is permitted. This parameter is valid for $T_{amb} = 25\text{ }^{\circ}\text{C}$ only.[7] I_{CC} is measured with outputs pulled to V_{CC} or GND.[8] This is the increase in supply current for each input at the specified voltage level other than V_{CC} or GND.[9] Typical values are at $V_{CC} = 3.3\text{ V}$ and $T_{amb} = 25\text{ }^{\circ}\text{C}$.[10] This parameter is valid for any V_{CC} between 0 V and 1.2 V with a transition time of up to 10 ms . From $V_{CC} = 1.2\text{ V}$ to $V_{CC} = 3.3\text{ V} \pm 0.3\text{ V}$ a transition time of $100\text{ }\mu\text{s}$ is permitted. This parameter is valid for $T_{amb} = 25\text{ }^{\circ}\text{C}$ only.

11. Dynamic characteristics

Table 8: Dynamic characteristics

$T_{amb} = -40\text{ }^{\circ}\text{C}$ to $+85\text{ }^{\circ}\text{C}$; $GND = 0\text{ V}$; for test circuit see [Figure 9](#).

Symbol	Parameter	Conditions	Min	Typ	Max	Unit
$V_{CC} = 2.5\text{ V} \pm 0.2\text{ V}$ [1]						
f_{max}	maximum clock frequency	see Figure 5	150	-	-	MHz
t_{PLH}	propagation delay nCP to nQx	see Figure 5	1.5	2.6	4.2	ns
t_{PHL}	propagation delay nCP to nQx	see Figure 5	1.5	2.8	4.5	ns
t_{PZH}	output enable time to HIGH-level	see Figure 6	1.0	3.4	5.6	ns
t_{PZL}	output enable time to LOW-level	see Figure 7	1.0	2.6	4.7	ns
t_{PHZ}	output disable time from HIGH-level	see Figure 6	2.0	2.7	4.4	ns
t_{PLZ}	output disable time from LOW-level	see Figure 7	1.0	2.0	3.3	ns
$t_{su(H)}$	setup time HIGH nDx to nCP	see Figure 8	1.0	0	-	ns
$t_{su(L)}$	setup time LOW nDx to nCP	see Figure 8	1.5	0.4	-	ns
$t_{h(H)}$	hold time HIGH nDx to nCP	see Figure 8	0.5	0	-	ns
$t_{h(L)}$	hold time LOW nDx to nCP	see Figure 8	0.5	0	-	ns
t_{WH}	nCP pulse width HIGH	see Figure 5	1.5	-	-	ns
t_{WL}	nCP pulse width LOW	see Figure 5	1.5	-	-	ns
$V_{CC} = 3.3\text{ V} \pm 0.3\text{ V}$ [2]						
f_{max}	maximum clock frequency	see Figure 5	250	-	-	MHz
t_{PLH}	propagation delay nCP to nQx	see Figure 5	1.0	2.1	3.2	ns
t_{PHL}	propagation delay nCP to nQx	see Figure 5	1.0	2.3	3.2	ns
t_{PZH}	output enable time to HIGH-level	see Figure 6	1.0	2.3	3.8	ns
t_{PZL}	output enable time to LOW-level	see Figure 7	1.0	2.0	3.2	ns
t_{PHZ}	output disable time from HIGH-level	see Figure 6	1.0	2.7	4.2	ns
t_{PLZ}	output disable time from LOW-level	see Figure 7	1.0	2.6	3.6	ns
$t_{su(H)}$	setup time HIGH nDx to nCP	see Figure 8	1.0	0	-	ns
$t_{su(L)}$	setup time LOW nDx to nCP	see Figure 8	1.5	0	-	ns
$t_{h(H)}$	hold time HIGH nDx to nCP	see Figure 8	0.5	0	-	ns
$t_{h(L)}$	hold time LOW nDx to nCP	see Figure 8	0.5	0	-	ns
t_{WH}	nCP pulse width HIGH	see Figure 5	1.5	-	-	ns
t_{WL}	nCP pulse width LOW	see Figure 5	1.5	-	-	ns

[1] Typical values are at $V_{CC} = 2.5\text{ V}$ and $T_{amb} = 25\text{ }^{\circ}\text{C}$.

[2] Typical values are at $V_{CC} = 3.3\text{ V}$ and $T_{amb} = 25\text{ }^{\circ}\text{C}$.

12. Waveforms

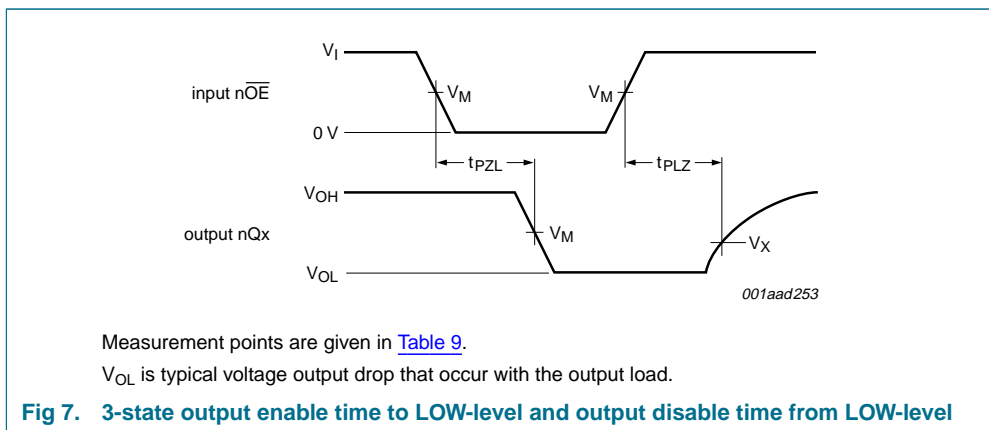
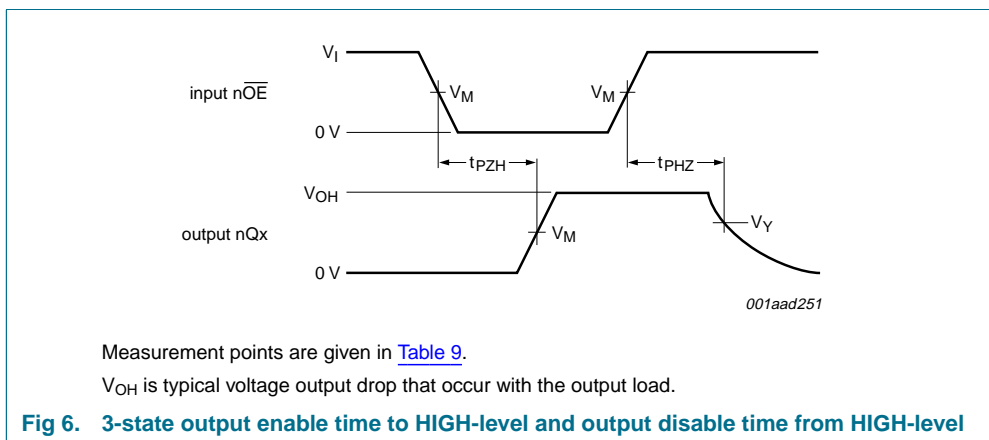
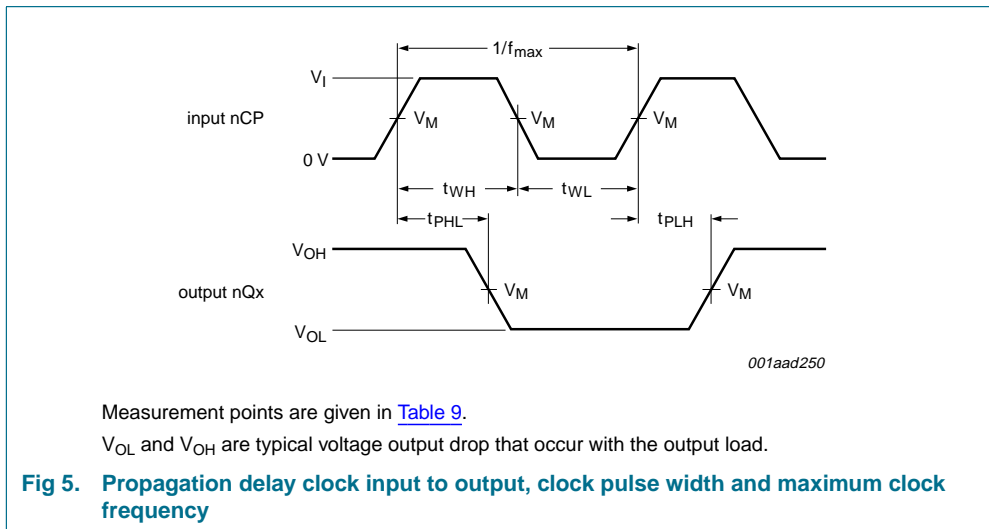

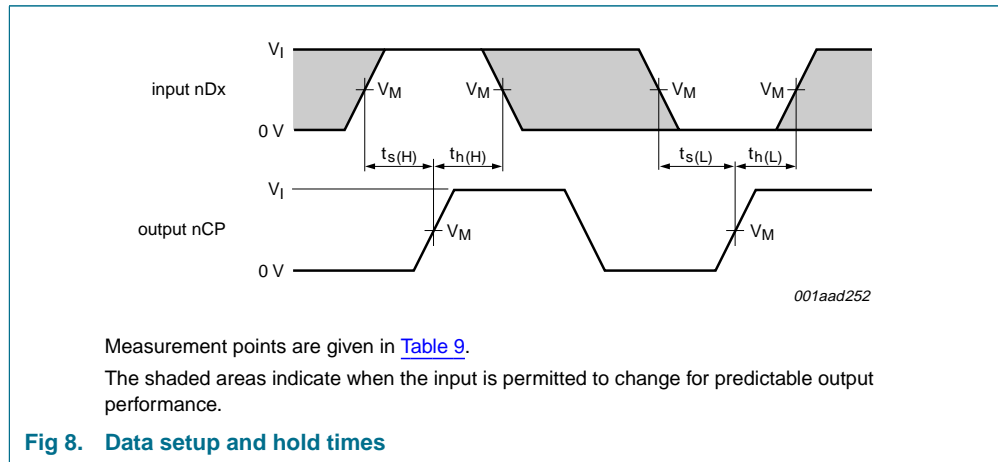

Table 9: Measurement points

Supply voltage	Input	Output		
	V_M	V_M	V_X	V_Y
$\geq 3\text{ V}$	1.5 V	1.5 V	$V_{OL} + 0.3\text{ V}$	$V_{OH} - 0.3\text{ V}$
$\leq 2.7\text{ V}$	$0.5 \times V_{CC}$	$0.5 \times V_{CC}$	$V_{OL} + 0.15\text{ V}$	$V_{OH} - 0.15\text{ V}$

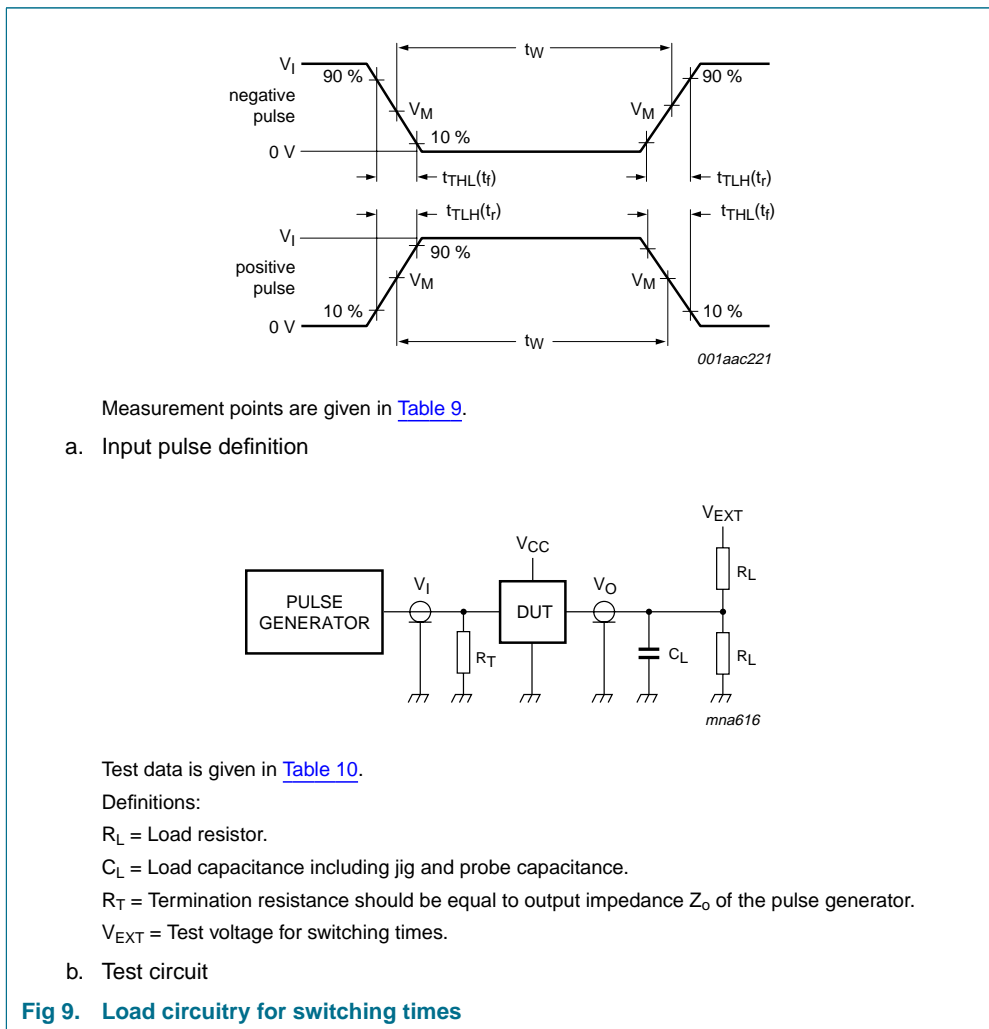

Table 10: Test data

Input				Load		V_{EXT}		
V_I	f_i	t_w	t_r, t_f	C_L	R_L	t_{PLH}, t_{PHL}	t_{PHZ}, t_{PZH}	t_{PLZ}, t_{PZL}
3.0 V or V_{CC} whichever is less	≤ 10 MHz	500 ns	≤ 2.5 ns	50 pF	500 Ω	open	GND	6 V or $2 \times V_{CC}$

13. Package outline

TSSOP48: plastic thin shrink small outline package; 48 leads; body width 6.1 mm

SOT362-1

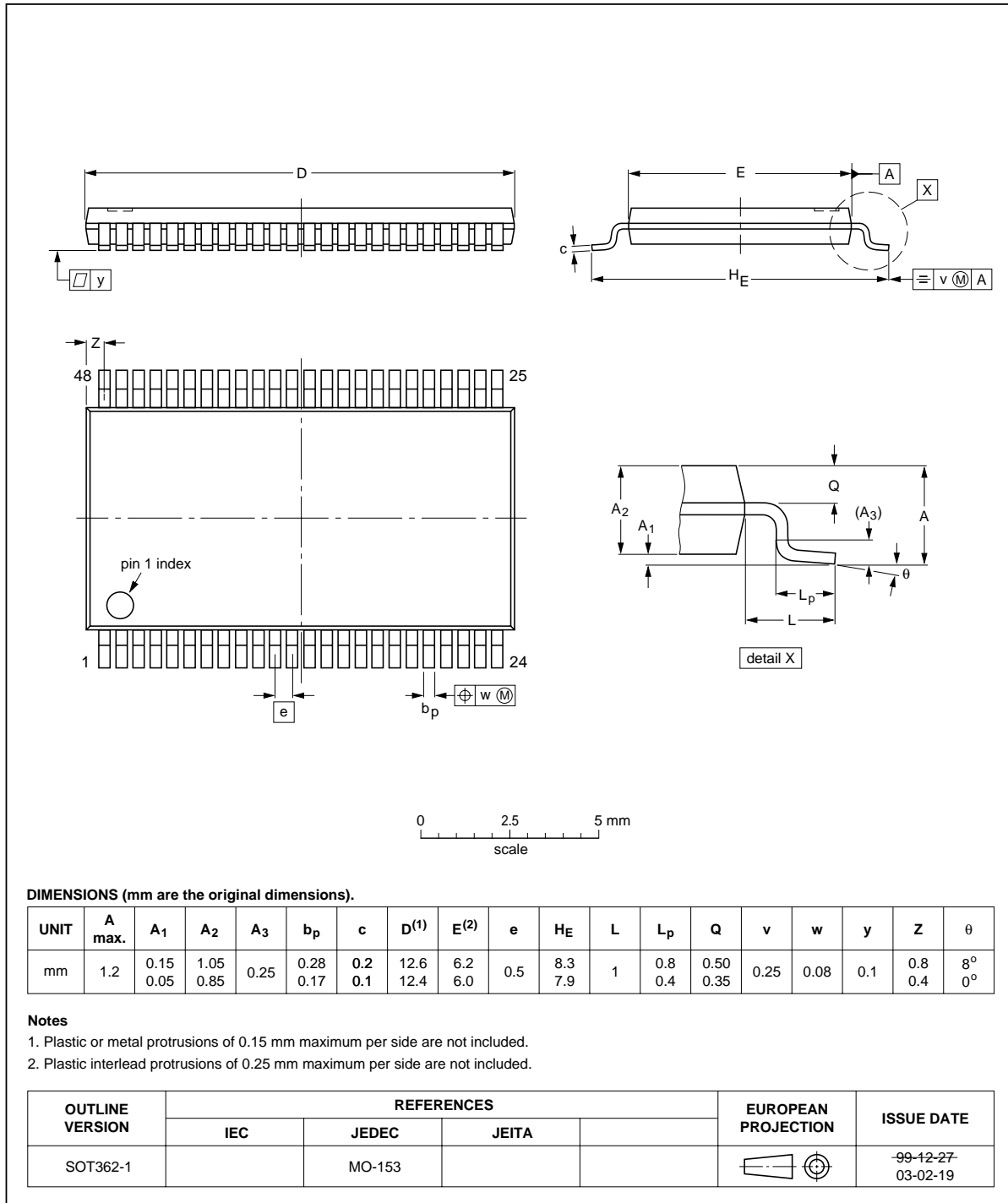

Fig 10. Package outline SOT362-1 (TSSOP48)

SSOP48: plastic shrink small outline package; 48 leads; body width 7.5 mm

SOT370-1

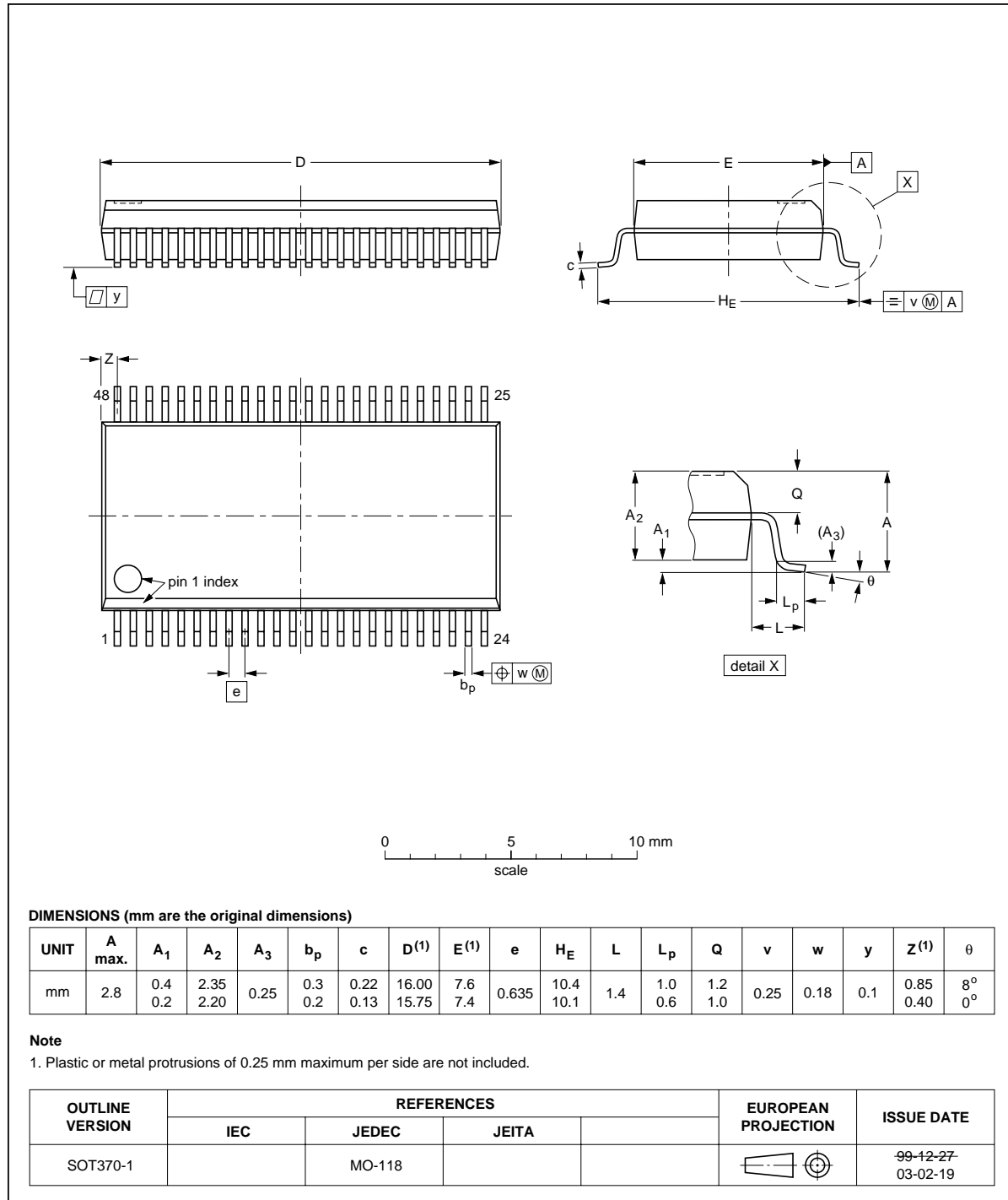

Fig 11. Package outline SOT370-1 (SSOP48)

14. Revision history

Table 11: Revision history

Document ID	Release date	Data sheet status	Change notice	Doc. number	Supersedes
74ALVT16374_4	20050704	Product data sheet	-	9397 750 15193	74ALVT16374_3
Modifications:					
<ul style="list-style-type: none"> The format of this data sheet has been redesigned to comply with the new presentation and information standard of Philips Semiconductors. Section 2 "Features": Changed JEDEC Std 17 to JESD78 Section 11 "Dynamic characteristics": Changed t_{PLZ} typical value to 2.6 ns and maximum value to 3.6 ns 					
74ALVT16374_3	19991018	Product specification	-	9397 750 06513	74ALVT16374_2
74ALVT16374_2	19980213	Product specification	-	9397 750 03565	74ALVT16374_1
74ALVT16374_1	19960610	Product specification	-	-	-

15. Data sheet status

Level	Data sheet status [1]	Product status [2] [3]	Definition
I	Objective data	Development	This data sheet contains data from the objective specification for product development. Philips Semiconductors reserves the right to change the specification in any manner without notice.
II	Preliminary data	Qualification	This data sheet contains data from the preliminary specification. Supplementary data will be published at a later date. Philips Semiconductors reserves the right to change the specification without notice, in order to improve the design and supply the best possible product.
III	Product data	Production	This data sheet contains data from the product specification. Philips Semiconductors reserves the right to make changes at any time in order to improve the design, manufacturing and supply. Relevant changes will be communicated via a Customer Product/Process Change Notification (CPCN).

[1] Please consult the most recently issued data sheet before initiating or completing a design.

[2] The product status of the device(s) described in this data sheet may have changed since this data sheet was published. The latest information is available on the Internet at URL <http://www.semiconductors.philips.com>.

[3] For data sheets describing multiple type numbers, the highest-level product status determines the data sheet status.

16. Definitions

Short-form specification — The data in a short-form specification is extracted from a full data sheet with the same type number and title. For detailed information see the relevant data sheet or data handbook.

Limiting values definition — Limiting values given are in accordance with the Absolute Maximum Rating System (IEC 60134). Stress above one or more of the limiting values may cause permanent damage to the device. These are stress ratings only and operation of the device at these or at any other conditions above those given in the Characteristics sections of the specification is not implied. Exposure to limiting values for extended periods may affect device reliability.

Application information — Applications that are described herein for any of these products are for illustrative purposes only. Philips Semiconductors make no representation or warranty that such applications will be suitable for the specified use without further testing or modification.

customers using or selling these products for use in such applications do so at their own risk and agree to fully indemnify Philips Semiconductors for any damages resulting from such application.

Right to make changes — Philips Semiconductors reserves the right to make changes in the products - including circuits, standard cells, and/or software - described or contained herein in order to improve design and/or performance. When the product is in full production (status 'Production'), relevant changes will be communicated via a Customer Product/Process Change Notification (CPCN). Philips Semiconductors assumes no responsibility or liability for the use of any of these products, conveys no license or title under any patent, copyright, or mask work right to these products, and makes no representations or warranties that these products are free from patent, copyright, or mask work right infringement, unless otherwise specified.

17. Disclaimers

Life support — These products are not designed for use in life support appliances, devices, or systems where malfunction of these products can reasonably be expected to result in personal injury. Philips Semiconductors

18. Trademarks

Notice — All referenced brands, product names, service names and trademarks are the property of their respective owners.

19. Contact information

For additional information, please visit: <http://www.semiconductors.philips.com>

For sales office addresses, send an email to: sales.addresses@www.semiconductors.philips.com

20. Contents

1	General description	1
2	Features	1
3	Quick reference data	2
4	Ordering information	2
5	Functional diagram	3
6	Pinning information	4
6.1	Pinning	4
6.2	Pin description	4
7	Functional description	6
7.1	Function table	6
8	Limiting values	6
9	Recommended operating conditions	7
10	Static characteristics	7
11	Dynamic characteristics	10
12	Waveforms	11
13	Package outline	14
14	Revision history	16
15	Data sheet status	17
16	Definitions	17
17	Disclaimers	17
18	Trademarks	17
19	Contact information	17



© Koninklijke Philips Electronics N.V. 2005

All rights are reserved. Reproduction in whole or in part is prohibited without the prior written consent of the copyright owner. The information presented in this document does not form part of any quotation or contract, is believed to be accurate and reliable and may be changed without notice. No liability will be accepted by the publisher for any consequence of its use. Publication thereof does not convey nor imply any license under patent- or other industrial or intellectual property rights.

Date of release: 4 July 2005
Document number: 9397 750 15193

Published in The Netherlands