

74ALVC164245

16-bit dual supply translating transceiver; 3-state

Rev. 8 — 15 March 2012

Product data sheet

1. General description

The 74ALVC164245 is a high-performance, low-power, low-voltage, Si-gate CMOS device, superior to most advanced CMOS compatible TTL families.

The 74ALVC164245 is a 16-bit (dual octal) dual supply translating transceiver featuring non-inverting 3-state bus compatible outputs in both send and receive directions. It is designed to interface between a 3 V and 5 V bus in a mixed 3 V and 5 V supply environment.

This device can be used as two 8-bit transceivers or one 16-bit transceiver.

The direction control inputs (1DIR and 2DIR) determine the direction of the data flow. nDIR (active HIGH) enables data from nAn ports to nBn ports. nDIR (active LOW) enables data from nBn ports to nAn ports. The output enable inputs (1OE and 2OE), when HIGH, disable both nAn and nBn ports by placing them in a high-impedance OFF-state. Pins nAn, nOE and nDIR are referenced to $V_{CC(A)}$ and pins nBn are referenced to $V_{CC(B)}$.

In suspend mode, when one of the supply voltages is zero, there will be no current flow from the non-zero supply towards the zero supply. The nAn-outputs must be set 3-state and the voltage on the A-bus must be smaller than V_{diode} (typical 0.7 V). $V_{CC(B)} \geq V_{CC(A)}$ (except in suspend mode).

2. Features and benefits

- 5 V tolerant inputs/outputs for interfacing with 5 V logic
- Wide supply voltage range:
 - ◆ 3 V port ($V_{CC(A)}$): 1.5 V to 3.6 V
 - ◆ 5 V port ($V_{CC(B)}$): 1.5 V to 5.5 V
- CMOS low power consumption
- Direct interface with TTL levels
- Control inputs voltage range from 2.7 V to 5.5 V
- Inputs accept voltages up to 5.5 V
- High-impedance outputs when $V_{CC(A)}$ or $V_{CC(B)} = 0$ V
- Complies with JEDEC standard JESD8-B/JESD36
- ESD protection:
 - ◆ HBM JESD22-A114F exceeds 2000 V
 - ◆ MM JESD22-A115-A exceeds 200 V
- Specified from -40 °C to $+85$ °C and -40 °C to $+125$ °C



3. Ordering information

Table 1. Ordering information

Type number	Temperature range	Package		
		Name	Description	Version
74ALVC164245DL	-40 °C to +125 °C	SSOP48	plastic shrink small outline package; 48 leads; body width 7.5 mm	SOT370-1
74ALVC164245DGG	-40 °C to +125 °C	TSSOP48	plastic thin shrink small outline package; 48 leads; body width 6.1 mm	SOT362-1
74ALVC164245BX	-40 °C to +125 °C	HXQFN60	plastic compatible thermal enhanced extremely thin quad flat package; no leads; 60 terminals; body 4 × 6 × 0.5 mm	SOT1134-2

4. Functional diagram

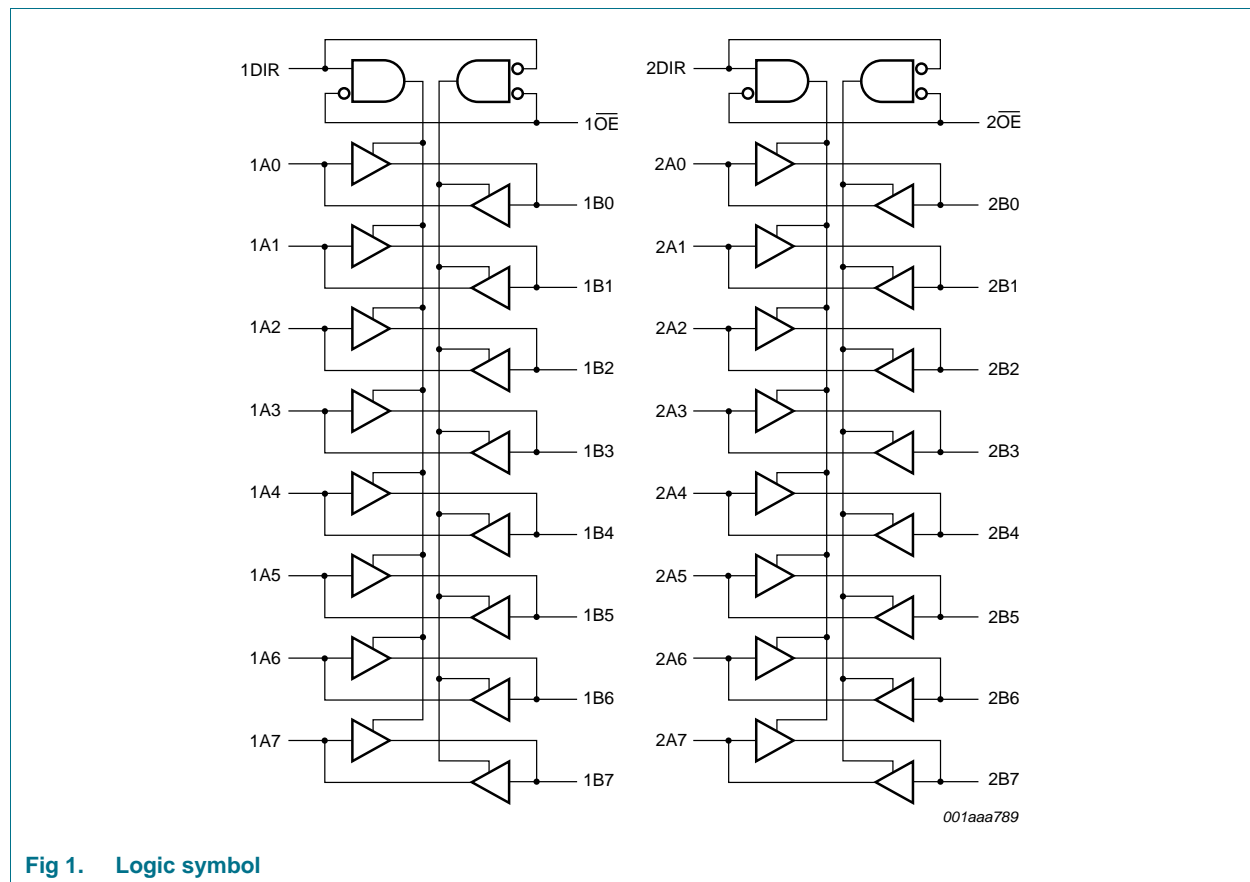

Fig 1. Logic symbol

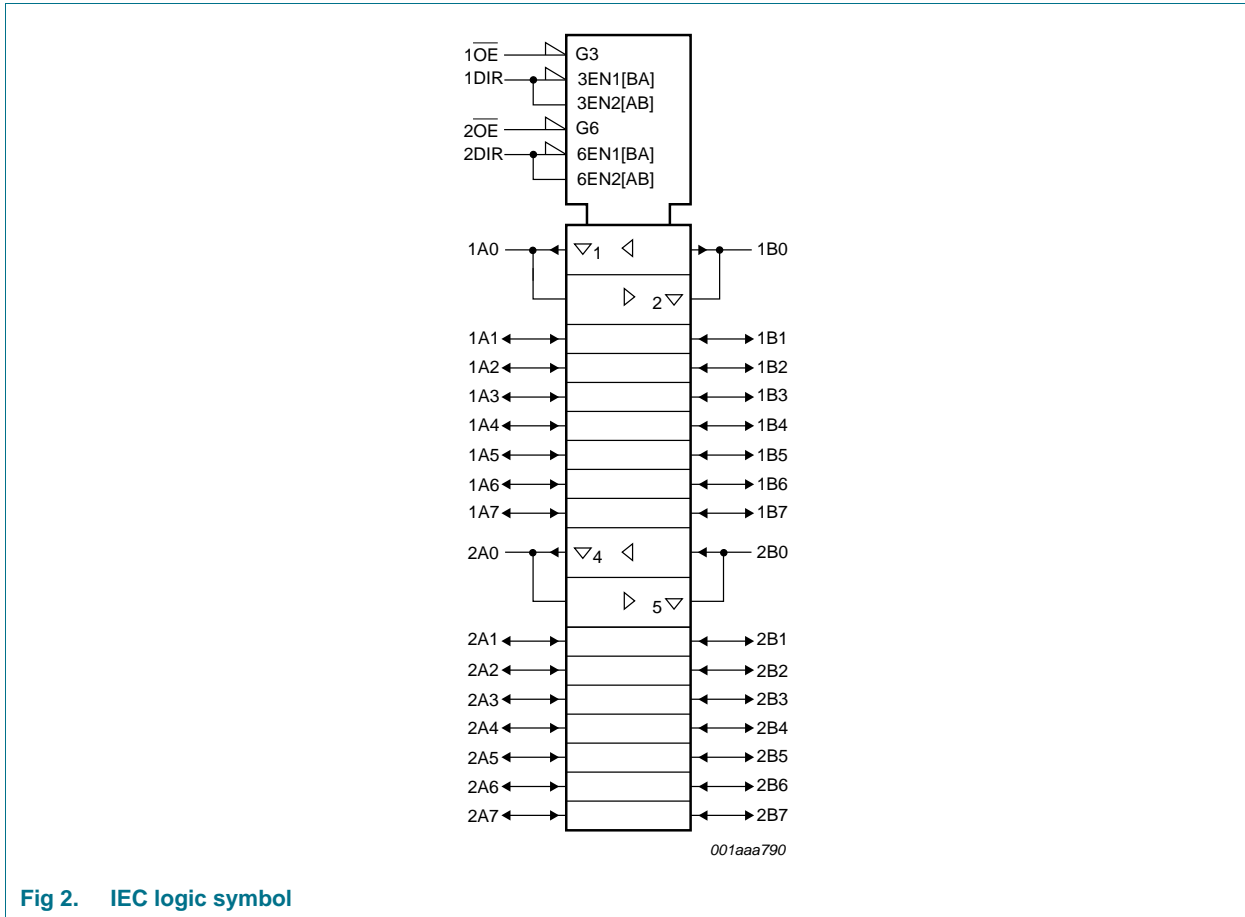

Fig 2. IEC logic symbol

5. Pinning information

5.1 Pinning

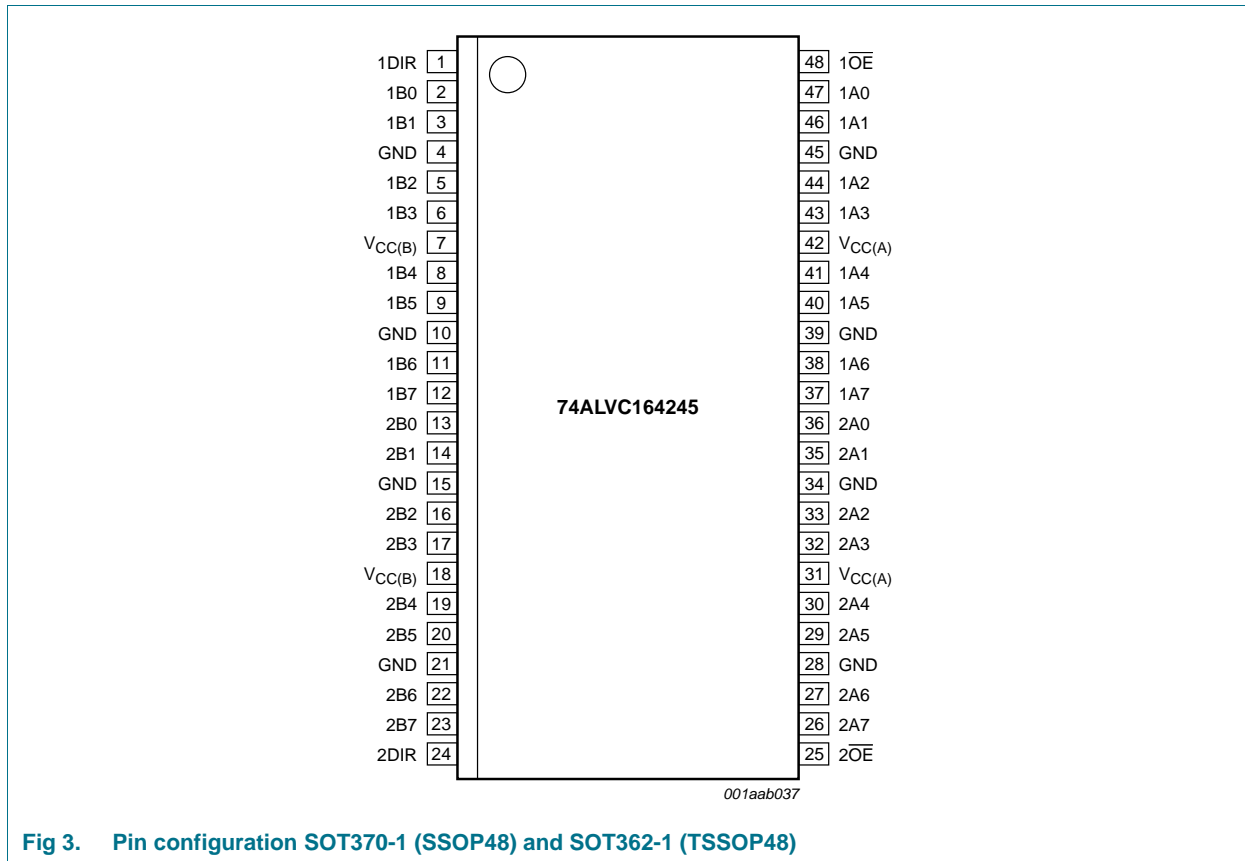
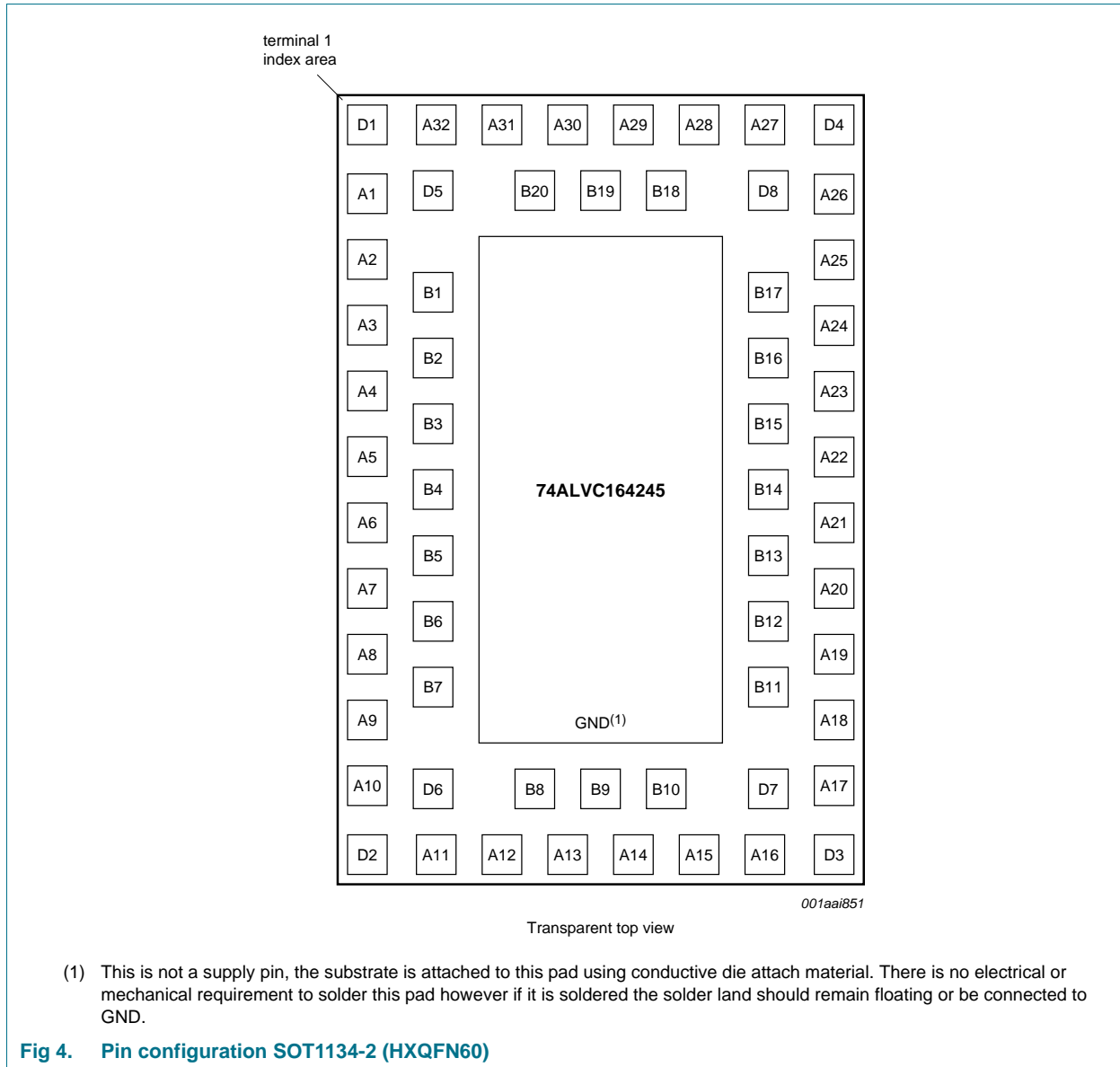

Fig 3. Pin configuration SOT370-1 (SSOP48) and SOT362-1 (TSSOP48)



5.2 Pin description

Table 2. Pin description

Symbol	Pin		Description
	SOT370-1 and SOT362-1	SOT1134-2	
1DIR, 2DIR	1, 24	A30, A13	direction control input
1B0 to 1B7	2, 3, 5, 6, 8, 9, 11, 12	B20, A31, D5, D1, A2, B2, B3, A5	data input/output
2B0 to 2B7	13, 14, 16, 17, 19, 20, 22, 23	A6, B5, B6, A9, D2, D6, A12, B8	data input/output
GND	4, 10, 15, 21, 28, 34, 39, 45	A32, A3, A8, A11, A16, A19, A24, A27	ground (0 V)
V _{CC(B)}	7, 18	A1, A10,	supply voltage B (5 V bus)
$\overline{1OE}$, $\overline{2OE}$	48, 25	A29, A14	output enable input (active LOW)
1A0 to 1A7	47, 46, 44, 43, 41, 40, 38, 37	B18, A28, D8, D4, A25, B16, B15, A22	data input/output
2A0 to 2A7	36, 35, 33, 32, 30, 29, 27, 26	A21, B13, B12, A18, D3, D7, A15, B10	data input/output
V _{CC(A)}	31, 42	A17, A26	supply voltage A (3 V bus)
n.c.	-	A4, A7, A20, A23, B1, B4, B7, B9, B11, B14, B17, B19	not connected

6. Functional description

Table 3. Function table^[1]

Inputs		Outputs	
nOE	nDIR	nAn	nBn
L	L	nAn = nBn	inputs
L	H	inputs	nBn = nAn
H	X	Z	Z

[1] H = HIGH voltage level; L = LOW voltage level; X = don't care; Z = high-impedance OFF-state.

7. Limiting values

Table 4. Limiting values

In accordance with the Absolute Maximum Rating System (IEC 60134). Voltages are referenced to GND (ground = 0 V). See ^[1].

Symbol	Parameter	Conditions	Min	Max	Unit
V _{CC(B)}	supply voltage B	V _{CC(B)} ≥ V _{CC(A)}	-0.5	+6.0	V
V _{CC(A)}	supply voltage A	V _{CC(B)} ≥ V _{CC(A)}	-0.5	+4.6	V
I _{IK}	input clamping current	V _I < 0 V	-50	-	mA
V _I	input voltage		^[2] -0.5	+6.0	V
V _{I/O}	input/output voltage		-0.5	V _{CC} + 0.5	V
I _{OK}	output clamping current	V _O > V _{CC} or V _O < 0 V	-	±50	mA
V _O	output voltage	output HIGH or LOW	^[2] -0.5	V _{CC} + 0.5	V
		output 3-state	^[2] -0.5	+6.0	V
I _{O(sink/source)}	output sink or source current	V _O = 0 V to V _{CC}	-	±50	mA
I _{CC}	supply current		-	100	mA

Table 4. Limiting values ...continued

In accordance with the Absolute Maximum Rating System (IEC 60134). Voltages are referenced to GND (ground = 0 V). See [1].

Symbol	Parameter	Conditions	Min	Max	Unit
I_{GND}	ground current		-100	-	mA
T_{stg}	storage temperature		-65	+150	°C
P_{tot}	total power dissipation	$T_{\text{amb}} = -40\text{ °C to }+125\text{ °C}$			
		(T)SSOP48 package	[3] -	500	mW
		HXQFN60 package	[4] -	1000	mW

[1] The performance capability of a high-performance integrated circuit in conjunction with its thermal environment can create junction temperatures which are detrimental to reliability. The maximum junction temperature of this integrated circuit should not exceed 150 °C.

[2] The input and output voltage ratings may be exceeded if the input and output current ratings are observed.

[3] Above 60 °C the value of P_{tot} derates linearly with 5.5 mW/K.

[4] Above 70 °C the value of P_{tot} derates linearly with 1.8 mW/K.

8. Recommended operating conditions

Table 5. Recommended operating conditions

Symbol	Parameter	Conditions	Min	Typ	Max	Unit
$V_{\text{CC(B)}}$	supply voltage B	$V_{\text{CC(B)}} \geq V_{\text{CC(A)}}$				
		maximum speed performance	2.7	-	5.5	V
		low-voltage applications	1.5	-	5.5	V
$V_{\text{CC(A)}}$	supply voltage A	$V_{\text{CC(B)}} \geq V_{\text{CC(A)}}$				
		maximum speed performance	2.7	-	3.6	V
		low-voltage applications	1.5	-	3.6	V
V_{I}	input voltage	control inputs: $\overline{\text{nOE}}$ and $\overline{\text{nDIR}}$	0	-	5.5	V
$V_{\text{I/O}}$	input/output voltage	nAn port	0	-	$V_{\text{CC(A)}}$	V
		nBn port	0	-	$V_{\text{CC(B)}}$	V
V_{O}	output voltage	nAn port	0	-	$V_{\text{CC(A)}}$	V
		nBn port	0	-	$V_{\text{CC(B)}}$	V
T_{amb}	ambient temperature		-40	-	+125	°C
$\Delta t/\Delta V$	input transition rise and fall rate	$V_{\text{CC(A)}} = 2.7\text{ V to }3.0\text{ V}$	0	-	20	ns/V
		$V_{\text{CC(A)}} = 3.0\text{ V to }3.6\text{ V}$	0	-	10	ns/V
		$V_{\text{CC(B)}} = 3.0\text{ V to }4.5\text{ V}$	0	-	20	ns/V
		$V_{\text{CC(B)}} = 4.5\text{ V to }5.5\text{ V}$	0	-	10	ns/V

9. Static characteristics

Table 6. Static characteristics

At recommended operating conditions; voltages are referenced to GND (ground = 0 V).

Symbol	Parameter	Conditions	T _{amb} = -40 °C to +85 °C			T _{amb} = -40 °C to +125 °C			Unit		
			Min	Typ ^[1]	Max	Min	Typ ^[1]	Max			
V _{IH}	HIGH-level input voltage	nBn port									
		V _{CC(B)} = 3.0 V to 5.5 V [2]	2.0	-	-	2.0	-	-	V		
		nAn port, n $\overline{\text{OE}}$ and nDIR									
		V _{CC(A)} = 3.0 V to 3.6 V	2.0	-	-	2.0	-	-	V		
		V _{CC(A)} = 2.3 V to 2.7 V [2]	1.7	-	-	1.7	-	-	V		
V _{IL}	LOW-level input voltage	nBn port									
		V _{CC(B)} = 4.5 V to 5.5 V [2]	-	-	0.8	-	-	0.8	V		
		V _{CC(B)} = 3.0 V to 3.6 V [2]	-	-	0.7	-	-	0.7	V		
		nAn port, n $\overline{\text{OE}}$ and nDIR									
		V _{CC(A)} = 3.0 V to 3.6 V	-	-	0.8	-	-	0.8	V		
		V _{CC(A)} = 2.3 V to 2.7 V [2]	-	-	0.7	-	-	0.7	V		
V _{OH}	HIGH-level output voltage	nBn port; V _I = V _{IH} or V _{IL}									
		I _O = -24 mA; V _{CC(B)} = 4.5 V	V _{CC(B)} - 0.8	-	-	V _{CC(B)} - 1.2	-	-	V		
		I _O = -12 mA; V _{CC(B)} = 4.5 V	V _{CC(B)} - 0.5	-	-	V _{CC(B)} - 0.8	-	-	V		
		I _O = -18 mA; V _{CC(B)} = 3.0 V	V _{CC(B)} - 0.8	-	-	V _{CC(B)} - 1.0	-	-	V		
		I _O = -100 μA; V _{CC(B)} = 3.0 V	V _{CC(B)} - 0.2	V _{CC(B)}	-	V _{CC(B)} - 0.3	V _{CC(B)}	-	V		
		nAn port; V _I = V _{IH} or V _{IL}									
		I _O = -24 mA; V _{CC(A)} = 3.0 V	V _{CC(A)} - 0.7	-	-	V _{CC(A)} - 1.0	-	-	V		
		I _O = -100 μA; V _{CC(A)} = 3.0 V	V _{CC(A)} - 0.2	-	-	V _{CC(A)} - 0.3	-	-	V		
		I _O = -12 mA; V _{CC(A)} = 2.7 V	V _{CC(A)} - 0.5	-	-	V _{CC(A)} - 0.8	-	-	V		
		I _O = -8 mA; V _{CC(A)} = 2.3 V	V _{CC(A)} - 0.6	-	-	V _{CC(A)} - 0.6	-	-	V		
		I _O = -100 μA; V _{CC(A)} = 2.3 V	V _{CC(A)} - 0.2	V _{CC(A)}	-	V _{CC(A)} - 0.3	V _{CC(A)}	-	V		
V _{OL}	LOW-level output voltage	nBn port; V _I = V _{IH} or V _{IL}									
		I _O = 24 mA; V _{CC(B)} = 4.5 V	-	-	0.55	-	-	0.60	V		
		I _O = 12 mA; V _{CC(B)} = 4.5 V	-	-	0.40	-	-	0.80	V		
		I _O = 100 μA; V _{CC(B)} = 4.5 V	-	-	0.20	-	-	0.30	V		
		I _O = 18 mA; V _{CC(B)} = 3.0 V	-	-	0.55	-	-	0.80	V		
		I _O = 100 μA; V _{CC(B)} = 3.0 V	-	-	0.20	-	-	0.30	V		
		nAn port; V _I = V _{IH} or V _{IL}									
		I _O = 24 mA; V _{CC(A)} = 3.0 V	-	-	0.55	-	-	0.80	V		
		I _O = 100 μA; V _{CC(A)} = 3.0 V	-	-	0.20	-	-	0.30	V		
		I _O = 12 mA; V _{CC(A)} = 2.7 V	-	-	0.40	-	-	0.60	V		
		I _O = 12 mA; V _{CC(A)} = 2.3 V	-	-	0.60	-	-	0.60	V		
				I _O = 100 μA; V _{CC(A)} = 2.3 V	-	-	0.20	-	-	0.20	V
		I _I	input leakage current	V _I = 5.5 V or GND	-	±0.1	±5	-	±0.1	±10	μA
I _{OZ}	OFF-state output current	V _I = V _{IH} or V _{IL} ; V _O = V _{CC} or GND [3]	-	±0.1	±10	-	±0.1	±20	μA		

Table 6. Static characteristics ...continued

At recommended operating conditions; voltages are referenced to GND (ground = 0 V).

Symbol	Parameter	Conditions	T _{amb} = -40 °C to +85 °C			T _{amb} = -40 °C to +125 °C			Unit
			Min	Typ ^[1]	Max	Min	Typ ^[1]	Max	
I _{CC}	supply current	V _I = V _{CC} or GND; I _O = 0 A	-	0.1	40	-	0.1	80	μA
ΔI _{CC}	additional supply current	per control pin; V _I = V _{CC} - 0.6 V; I _O = 0 A	-	5	500	-	5	5000	μA
C _I	input capacitance		-	4.0	-	-	-	-	pF
C _{I/O}	input/output capacitance	nAn and nBn port	-	5.0	-	-	-	-	pF

[1] All typical values are measured at V_{CC(B)} = 5.0 V, V_{CC(A)} = 3.3 V and T_{amb} = 25 °C.[2] If V_{CC(A)} < 2.7 V, the switching levels at all inputs are not TTL compatible.[3] For transceivers, the parameter I_{OZ} includes the input leakage current.[4] V_{CC(A)} = 2.7 V to 3.6 V; other inputs at V_{CC(A)} or GND; V_{CC(B)} = 4.5 V to 5.5 V; other inputs at V_{CC(B)} or GND.

10. Dynamic characteristics

Table 7. Dynamic characteristicsGND = 0 V; t_r = t_f ≤ 2.5 ns; C_L = 50 pF; for test circuit see [Figure 7](#).

Symbol	Parameter	Conditions	T _{amb} = -40 °C to +85 °C			T _{amb} = -40 °C to +125 °C		Unit
			Min	Typ ^[1]	Max	Min	Max	
t _{pd}	propagation delay	nAn to nBn; see Figure 5 ^[2]						
		V _{CC(A)} = 2.3 V to 2.7 V; V _{CC(B)} = 3.0 V to 3.6 V	1.5	3.3	7.6	1.5	9.5	ns
		V _{CC(A)} = 2.7 V; V _{CC(B)} = 4.5 V to 5.5 V	1.0	3.0	5.9	1.0	7.5	ns
		V _{CC(A)} = 3.0 V to 3.6 V; V _{CC(B)} = 4.5 V to 5.5 V	1.0	2.9	5.8	1.0	7.5	ns
		nBn to nAn; see Figure 5 ^[2]						
		V _{CC(A)} = 2.3 V to 2.7 V; V _{CC(B)} = 3.0 V to 3.6 V	1.0	3.0	7.6	1.0	9.5	ns
		V _{CC(A)} = 2.7 V; V _{CC(B)} = 4.5 V to 5.5 V	1.0	4.3	6.7	1.0	8.5	ns
		V _{CC(A)} = 3.0 V to 3.6 V; V _{CC(B)} = 4.5 V to 5.5 V	1.2	2.5	5.8	1.2	7.5	ns

Table 7. Dynamic characteristics ...continued
GND = 0 V; $t_r = t_f \leq 2.5$ ns; $C_L = 50$ pF; for test circuit see [Figure 7](#).

Symbol	Parameter	Conditions	T _{amb} = -40 °C to +85 °C			T _{amb} = -40 °C to +125 °C		Unit		
			Min	Typ ^[1]	Max	Min	Max			
t _{en}	enable time	n $\overline{\text{OE}}$ to nBn; see Figure 6 ^[2]								
		V _{CC(A)} = 2.3 V to 2.7 V; V _{CC(B)} = 3.0 V to 3.6 V	1.5	4.1	11.5	1.5	14.5	ns		
		V _{CC(A)} = 2.7 V; V _{CC(B)} = 4.5 V to 5.5 V	1.5	3.6	9.2	1.5	11.5	ns		
		V _{CC(A)} = 3.0 V to 3.6 V; V _{CC(B)} = 4.5 V to 5.5 V	1.0	3.2	8.9	1.0	12.0	ns		
		n $\overline{\text{OE}}$ to nAn; see Figure 6 ^[2]								
		V _{CC(A)} = 2.3 V to 2.7 V; V _{CC(B)} = 3.0 V to 3.6 V	1.5	4.6	12.3	1.5	15.5	ns		
		V _{CC(A)} = 2.7 V; V _{CC(B)} = 4.5 V to 5.5 V	1.5	4.3	9.3	1.5	12.0	ns		
		V _{CC(A)} = 3.0 V to 3.6 V; V _{CC(B)} = 4.5 V to 5.5 V	1.0	3.2	8.9	1.0	11.5	ns		
		t _{dis}	disable time	n $\overline{\text{OE}}$ to nBn; see Figure 6 ^[2]						
				V _{CC(A)} = 2.3 V to 2.7 V; V _{CC(B)} = 3.0 V to 3.6 V	2.0	2.7	10.5	2.0	13.5	ns
V _{CC(A)} = 2.7 V; V _{CC(B)} = 4.5 V to 5.5 V	2.5			4.6	9.0	2.5	11.5	ns		
V _{CC(A)} = 3.0 V to 3.6 V; V _{CC(B)} = 4.5 V to 5.5 V	2.1			4.9	8.6	2.1	11.0	ns		
n $\overline{\text{OE}}$ to nAn; see Figure 6 ^[2]										
V _{CC(A)} = 2.3 V to 2.7 V; V _{CC(B)} = 3.0 V to 3.6 V	1.0			2.7	9.3	1.0	12.0	ns		
V _{CC(A)} = 2.7 V; V _{CC(B)} = 4.5 V to 5.5 V	1.5			3.5	9.0	1.5	11.5	ns		
V _{CC(A)} = 3.0 V to 3.6 V; V _{CC(B)} = 4.5 V to 5.5 V	2.0			3.2	8.6	2.0	11.0	ns		

Table 7. Dynamic characteristics ...continued
GND = 0 V; $t_r = t_f \leq 2.5$ ns; $C_L = 50$ pF; for test circuit see Figure 7.

Symbol	Parameter	Conditions	T _{amb} = -40 °C to +85 °C			T _{amb} = -40 °C to +125 °C		Unit
			Min	Typ ^[1]	Max	Min	Max	
C _{PD}	power dissipation capacitance	5 V port: nAn to nBn; ^{[3][4]} V _{CC(B)} = 5 V; V _{CC(A)} = 3.3 V						
		outputs enabled	-	30	-	-	-	pF
		outputs disabled	-	15	-	-	-	pF
		3 V port: nBn to nAn; ^{[3][4]} V _{CC(B)} = 5 V; V _{CC(A)} = 3.3 V						
		outputs enabled	-	40	-	-	-	pF
		outputs disabled	-	5	-	-	-	pF

- [1] All typical values are measured at nominal voltage for V_{CC(B)} and V_{CC(A)} and at T_{amb} = 25 °C.
- [2] t_{pd} is the same as t_{PLH} and t_{PHL}.
 t_{en} is the same as t_{PZL} and t_{PZH}.
 t_{dis} is the same as t_{PLZ} and t_{PHZ}.
- [3] C_{PD} is used to determine the dynamic power dissipation (P_D in μW).
 $P_D = C_{PD} \times V_{CC}^2 \times f_i \times N + \Sigma(C_L \times V_{CC}^2 \times f_o)$ where:
 f_i = input frequency in MHz;
 f_o = output frequency in MHz;
 C_L = output load capacitance in pF;
 V_{CC} = supply voltage in V;
 N = number of inputs switching;
 Σ(C_L × V_{CC}² × f_o) = sum of outputs.
- [4] The condition is V_I = GND to V_{CC}.

11. AC waveforms

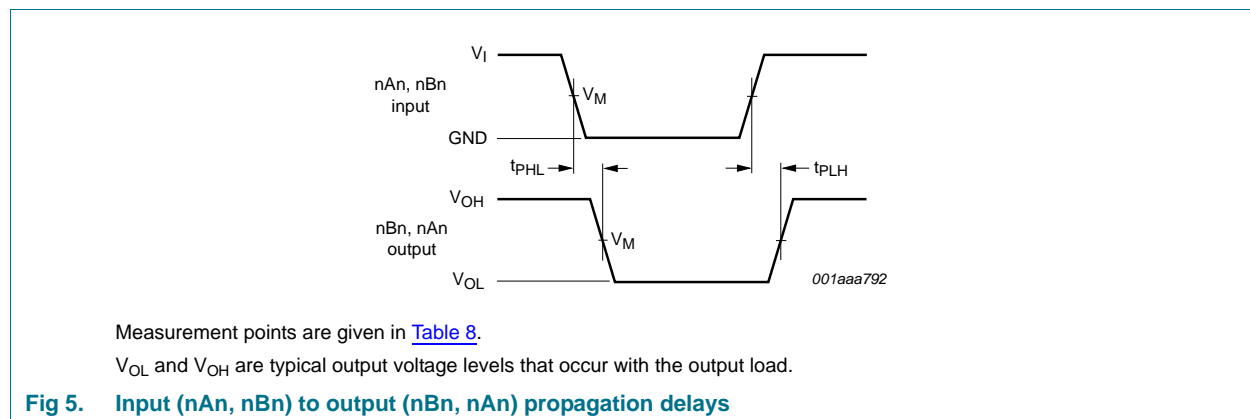

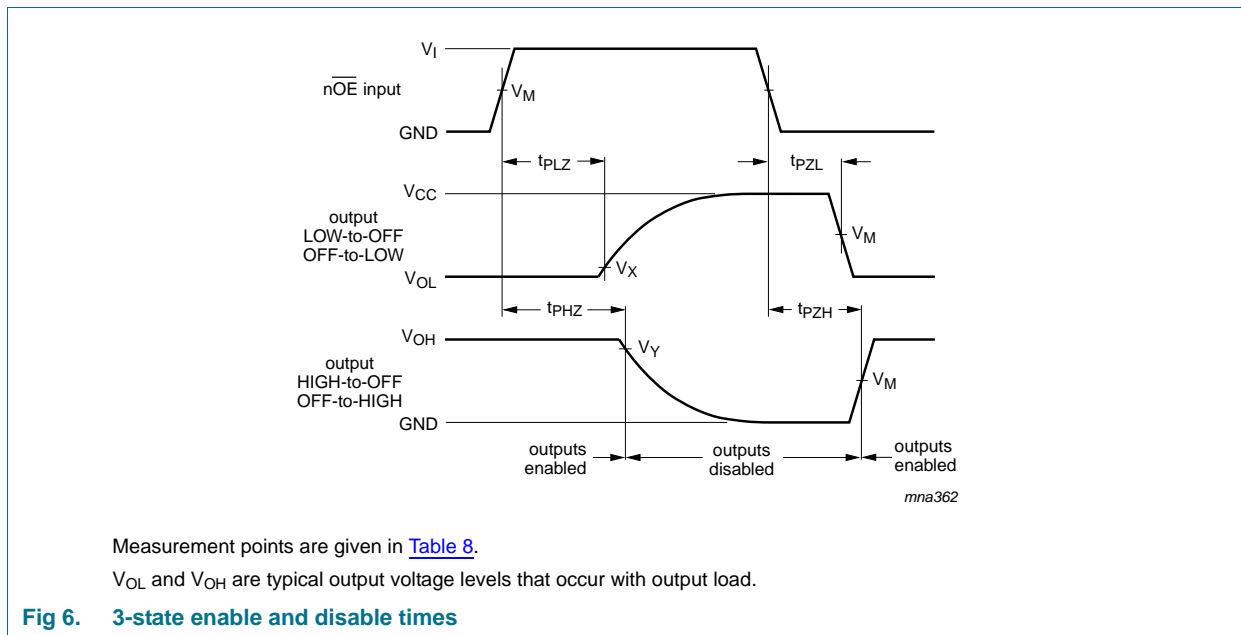

Table 8. Measurement points

Direction	Supply voltage		Input		Output		
	$V_{CC(A)}$	$V_{CC(B)}$	V_I	V_M	V_M	V_X	V_Y
nAn port to nBn port	2.3 V to 2.7 V	2.7 V to 3.6 V	$V_{CC(A)}$	$0.5 \times V_{CC(A)}$	1.5 V	$V_{OL(B)} + 0.3 V$	$V_{OH(B)} - 0.3 V$
nBn port to nAn port	2.3 V to 2.7 V	2.7 V to 3.6 V	2.7 V	1.5 V	$0.5 \times V_{CC(A)}$	$V_{OL(A)} + 0.15 V$	$V_{OH(A)} - 0.15 V$
nAn port to nBn port	2.7 V to 3.6 V	4.5 V to 5.5 V	2.7 V	1.5 V	$0.5 \times V_{CC(B)}$	$0.2 \times V_{CC(B)}$	$0.8 \times V_{CC(B)}$
nBn port to nAn port	2.7 V to 3.6 V	4.5 V to 5.5 V	3.0 V	1.5 V	1.5 V	$V_{OL(A)} + 0.3 V$	$V_{OH(A)} - 0.3 V$

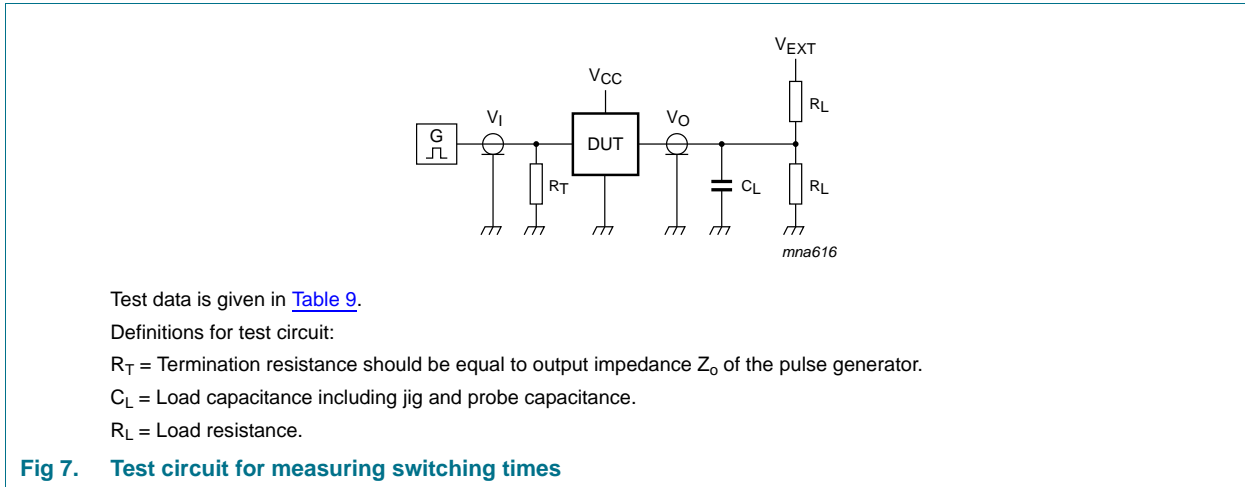

Table 9. Test data

Direction	Supply voltage		Load		V_{EXT}		
	$V_{CC(A)}$	$V_{CC(B)}$	C_L	R_L	t_{PLH}, t_{PHL}	t_{PZH}, t_{PHZ}	t_{PZL}, t_{PLZ}
nAn port to nBn port	2.3 V to 2.7 V	2.7 V to 3.6 V	50 pF	500 Ω	open	GND	$2 \times V_{CC}$
nBn port to nAn port	2.3 V to 2.7 V	2.7 V to 3.6 V	50 pF	500 Ω	open	GND	6.0 V
nAn port to nBn port	2.7 V to 3.6 V	4.5 V to 5.5 V	50 pF	500 Ω	open	GND	$2 \times V_{CC}$
nBn port to nAn port	2.7 V to 3.6 V	4.5 V to 5.5 V	50 pF	500 Ω	open	GND	6.0 V

12. Package outline

SSOP48: plastic shrink small outline package; 48 leads; body width 7.5 mm

SOT370-1

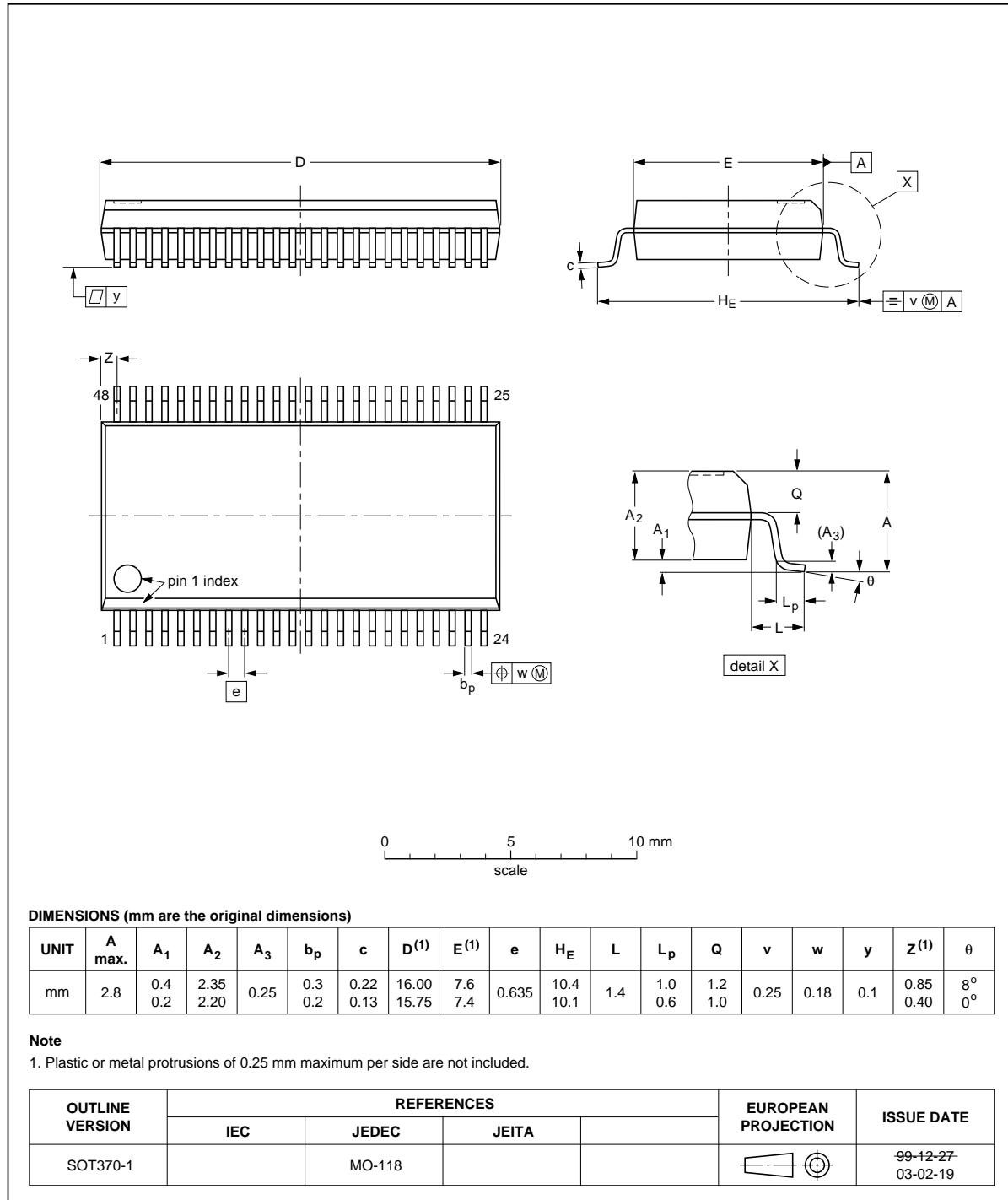

Fig 8. Package outline SOT370-1 (SSOP48)

TSSOP48: plastic thin shrink small outline package; 48 leads; body width 6.1 mm

SOT362-1

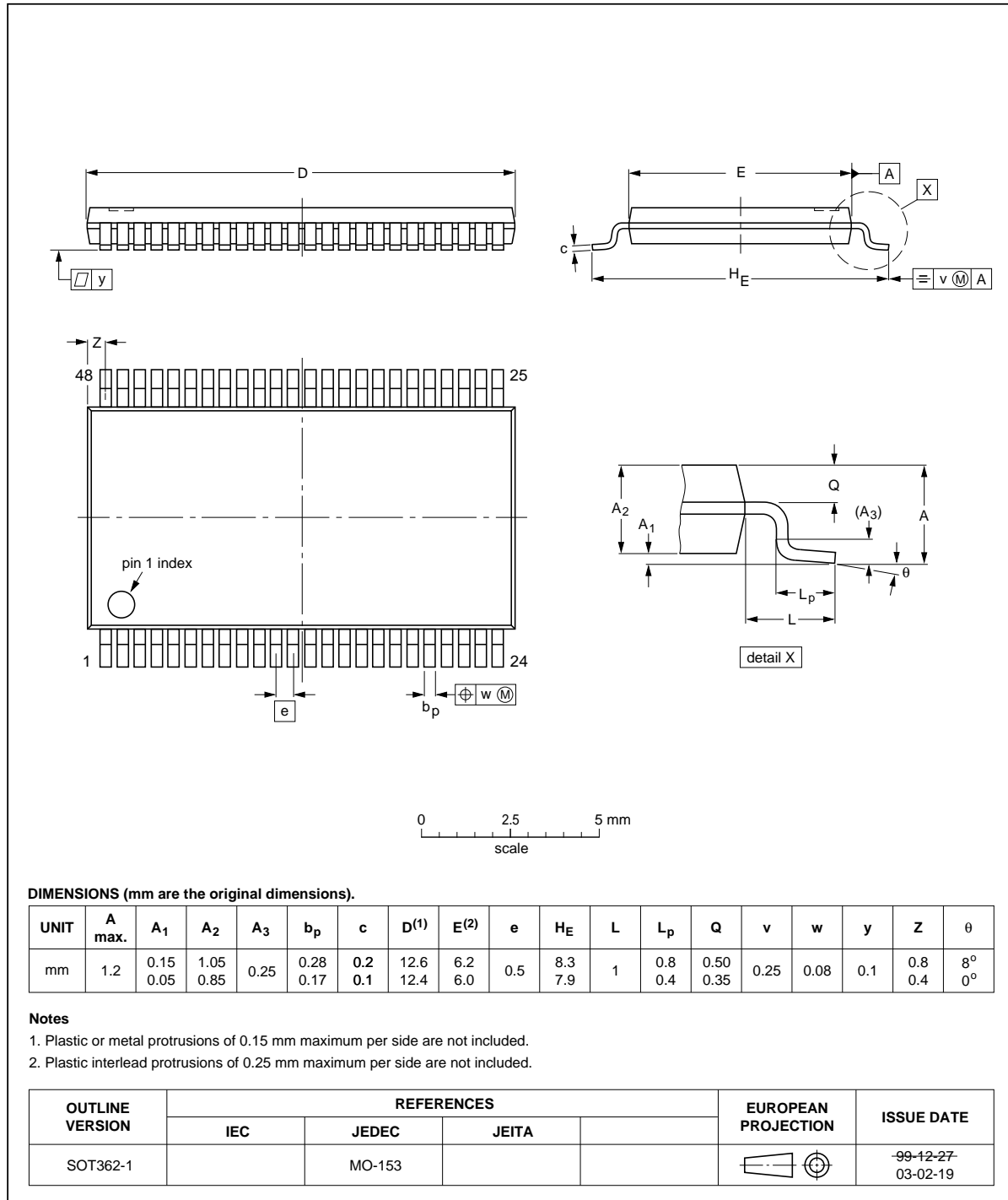

Fig 9. Package outline SOT362-1 (TSSOP48)

HXQFN60: plastic compatible thermal enhanced extremely thin quad flat package; no leads;
60 terminals; body 4 x 6 x 0.5 mm

SOT1134-2

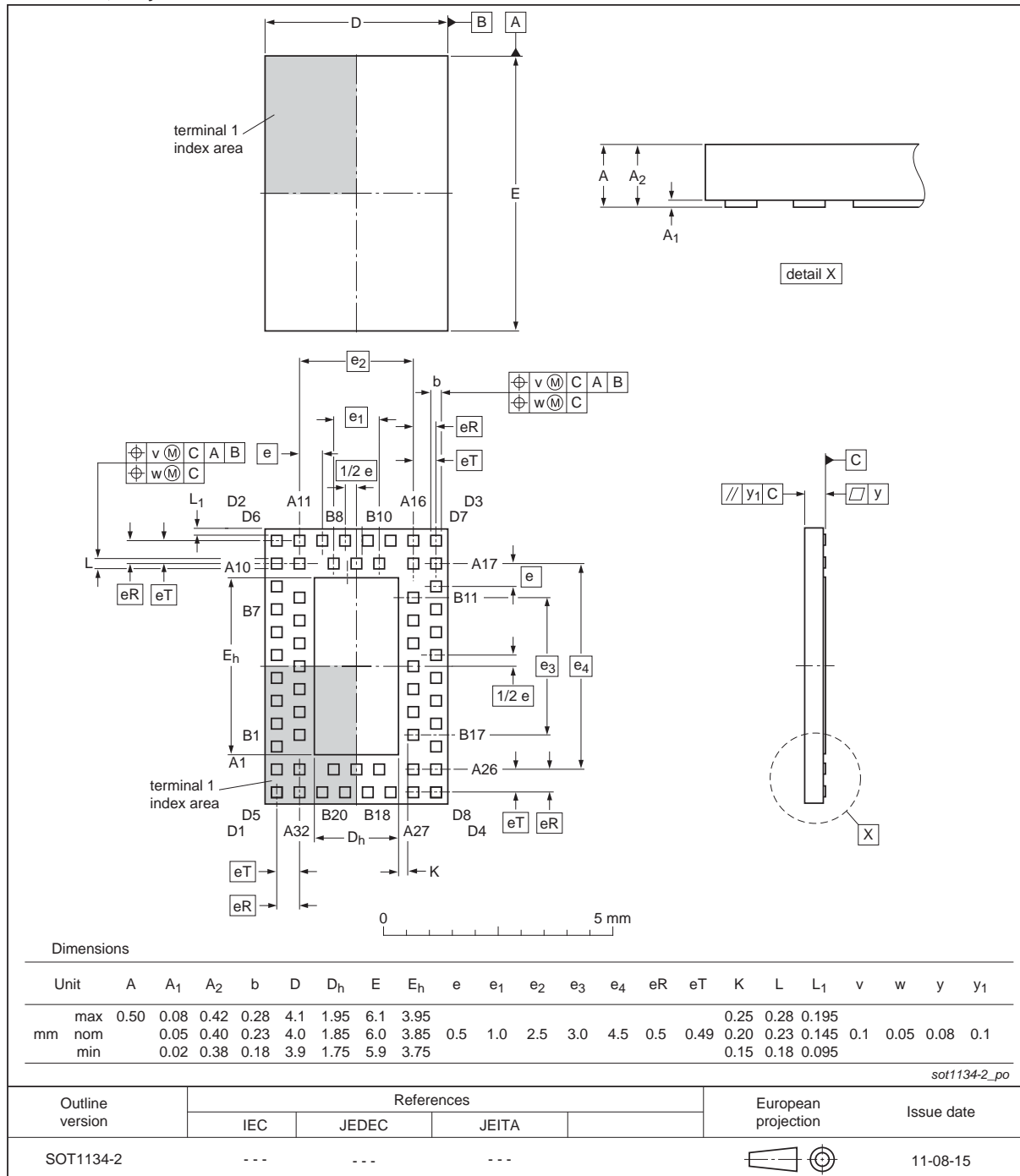

Fig 10. Package outline SOT1134-2 (HXQFN60)

13. Abbreviations

Table 10. Abbreviations

Acronym	Description
CMOS	Complementary Metal Oxide Semiconductor
DUT	Device Under Test
ESD	ElectroStatic Discharge
HBM	Human Body Model
MM	Machine Model
TTL	Transistor-Transistor Logic

14. Revision history

Table 11. Revision history

Document ID	Release date	Data sheet status	Change notice	Supersedes
74ALVC164245 v.8	20120315	Product data sheet	-	74ALVC164245 v.7
Modifications:	<ul style="list-style-type: none"> For type number 74ALVC164245BX the sot code has changed to SOT1134-2. 			
74ALVC164245 v.7	20111117	Product data sheet	-	74ALVC164245 v.6
Modifications:	<ul style="list-style-type: none"> Legal pages updated. 			
74ALVC164245 v.6	20110616	Product data sheet	-	74ALVC164245 v.5
74ALVC164245 v.5	20100413	Product data sheet	-	74ALVC164245 v.4
74ALVC164245 v.4	20081111	Product data sheet	-	74ALVC164245 v.3
74ALVC164245 v.3	20040914	Product data sheet	-	74ALVC164245 v.2
74ALVC164245 v.2	20040601	Product data sheet	-	74ALVC164245 v.1
74ALVC164245 v.1	19980826	Product specification	-	-

15. Legal information

15.1 Data sheet status

Document status ^{[1][2]}	Product status ^[3]	Definition
Objective [short] data sheet	Development	This document contains data from the objective specification for product development.
Preliminary [short] data sheet	Qualification	This document contains data from the preliminary specification.
Product [short] data sheet	Production	This document contains the product specification.

[1] Please consult the most recently issued document before initiating or completing a design.

[2] The term 'short data sheet' is explained in section "Definitions".

[3] The product status of device(s) described in this document may have changed since this document was published and may differ in case of multiple devices. The latest product status information is available on the Internet at URL <http://www.nxp.com>.

15.2 Definitions

Draft — The document is a draft version only. The content is still under internal review and subject to formal approval, which may result in modifications or additions. NXP Semiconductors does not give any representations or warranties as to the accuracy or completeness of information included herein and shall have no liability for the consequences of use of such information.

Short data sheet — A short data sheet is an extract from a full data sheet with the same product type number(s) and title. A short data sheet is intended for quick reference only and should not be relied upon to contain detailed and full information. For detailed and full information see the relevant full data sheet, which is available on request via the local NXP Semiconductors sales office. In case of any inconsistency or conflict with the short data sheet, the full data sheet shall prevail.

Product specification — The information and data provided in a Product data sheet shall define the specification of the product as agreed between NXP Semiconductors and its customer, unless NXP Semiconductors and customer have explicitly agreed otherwise in writing. In no event however, shall an agreement be valid in which the NXP Semiconductors product is deemed to offer functions and qualities beyond those described in the Product data sheet.

15.3 Disclaimers

Limited warranty and liability — Information in this document is believed to be accurate and reliable. However, NXP Semiconductors does not give any representations or warranties, expressed or implied, as to the accuracy or completeness of such information and shall have no liability for the consequences of use of such information. NXP Semiconductors takes no responsibility for the content in this document if provided by an information source outside of NXP Semiconductors.

In no event shall NXP Semiconductors be liable for any indirect, incidental, punitive, special or consequential damages (including - without limitation - lost profits, lost savings, business interruption, costs related to the removal or replacement of any products or rework charges) whether or not such damages are based on tort (including negligence), warranty, breach of contract or any other legal theory.

Notwithstanding any damages that customer might incur for any reason whatsoever, NXP Semiconductors' aggregate and cumulative liability towards customer for the products described herein shall be limited in accordance with the *Terms and conditions of commercial sale* of NXP Semiconductors.

Right to make changes — NXP Semiconductors reserves the right to make changes to information published in this document, including without limitation specifications and product descriptions, at any time and without notice. This document supersedes and replaces all information supplied prior to the publication hereof.

Suitability for use — NXP Semiconductors products are not designed, authorized or warranted to be suitable for use in life support, life-critical or safety-critical systems or equipment, nor in applications where failure or malfunction of an NXP Semiconductors product can reasonably be expected to result in personal injury, death or severe property or environmental damage. NXP Semiconductors and its suppliers accept no liability for inclusion and/or use of NXP Semiconductors products in such equipment or applications and therefore such inclusion and/or use is at the customer's own risk.

Applications — Applications that are described herein for any of these products are for illustrative purposes only. NXP Semiconductors makes no representation or warranty that such applications will be suitable for the specified use without further testing or modification.

Customers are responsible for the design and operation of their applications and products using NXP Semiconductors products, and NXP Semiconductors accepts no liability for any assistance with applications or customer product design. It is customer's sole responsibility to determine whether the NXP Semiconductors product is suitable and fit for the customer's applications and products planned, as well as for the planned application and use of customer's third party customer(s). Customers should provide appropriate design and operating safeguards to minimize the risks associated with their applications and products.

NXP Semiconductors does not accept any liability related to any default, damage, costs or problem which is based on any weakness or default in the customer's applications or products, or the application or use by customer's third party customer(s). Customer is responsible for doing all necessary testing for the customer's applications and products using NXP Semiconductors products in order to avoid a default of the applications and the products or of the application or use by customer's third party customer(s). NXP does not accept any liability in this respect.

Limiting values — Stress above one or more limiting values (as defined in the Absolute Maximum Ratings System of IEC 60134) will cause permanent damage to the device. Limiting values are stress ratings only and (proper) operation of the device at these or any other conditions above those given in the Recommended operating conditions section (if present) or the Characteristics sections of this document is not warranted. Constant or repeated exposure to limiting values will permanently and irreversibly affect the quality and reliability of the device.

Terms and conditions of commercial sale — NXP Semiconductors products are sold subject to the general terms and conditions of commercial sale, as published at <http://www.nxp.com/profile/terms>, unless otherwise agreed in a valid written individual agreement. In case an individual agreement is concluded only the terms and conditions of the respective agreement shall apply. NXP Semiconductors hereby expressly objects to applying the customer's general terms and conditions with regard to the purchase of NXP Semiconductors products by customer.

No offer to sell or license — Nothing in this document may be interpreted or construed as an offer to sell products that is open for acceptance or the grant, conveyance or implication of any license under any copyrights, patents or other industrial or intellectual property rights.

Export control — This document as well as the item(s) described herein may be subject to export control regulations. Export might require a prior authorization from competent authorities.

Non-automotive qualified products — Unless this data sheet expressly states that this specific NXP Semiconductors product is automotive qualified, the product is not suitable for automotive use. It is neither qualified nor tested in accordance with automotive testing or application requirements. NXP Semiconductors accepts no liability for inclusion and/or use of non-automotive qualified products in automotive equipment or applications.

In the event that customer uses the product for design-in and use in automotive applications to automotive specifications and standards, customer (a) shall use the product without NXP Semiconductors' warranty of the product for such automotive applications, use and specifications, and (b) whenever customer uses the product for automotive applications beyond

NXP Semiconductors' specifications such use shall be solely at customer's own risk, and (c) customer fully indemnifies NXP Semiconductors for any liability, damages or failed product claims resulting from customer design and use of the product for automotive applications beyond NXP Semiconductors' standard warranty and NXP Semiconductors' product specifications.

Translations — A non-English (translated) version of a document is for reference only. The English version shall prevail in case of any discrepancy between the translated and English versions.

15.4 Trademarks

Notice: All referenced brands, product names, service names and trademarks are the property of their respective owners.

16. Contact information

For more information, please visit: <http://www.nxp.com>

For sales office addresses, please send an email to: salesaddresses@nxp.com

17. Contents

1	General description	1
2	Features and benefits	1
3	Ordering information	2
4	Functional diagram	2
5	Pinning information	4
5.1	Pinning	4
5.2	Pin description	6
6	Functional description	6
7	Limiting values	6
8	Recommended operating conditions	7
9	Static characteristics	8
10	Dynamic characteristics	9
11	AC waveforms	11
12	Package outline	14
13	Abbreviations	17
14	Revision history	17
15	Legal information	18
15.1	Data sheet status	18
15.2	Definitions	18
15.3	Disclaimers	18
15.4	Trademarks	19
16	Contact information	19
17	Contents	20

Please be aware that important notices concerning this document and the product(s) described herein, have been included in section 'Legal information'.

© NXP B.V. 2012.

All rights reserved.

For more information, please visit: <http://www.nxp.com>

For sales office addresses, please send an email to: salesaddresses@nxp.com

Date of release: 15 March 2012

Document identifier: 74ALVC164245