

# 74AHC259; 74AHCT259

8-bit addressable latch

Rev. 02 — 15 May 2008

Product data sheet

## 1. General description

The 74AHC259; 74AHCT259 is a high-speed Si-gate CMOS device and is pin compatible with Low-power Schottky TTL (LSTTL). It is specified in compliance with JEDEC standard No. 7-A.

The 74AHC259; 74AHCT259 is a high-speed 8-bit addressable latch designed for general purpose storage applications in digital systems. It is a multifunctional device capable of storing single-line data in eight addressable latches and providing a 3-to-8 decoder and multiplexer function with active HIGH outputs (Q0 to Q7). It also incorporates an active LOW common reset ( $\overline{MR}$ ) for resetting all latches as well as an active LOW enable input ( $\overline{LE}$ ).

The 74AHC259; 74AHCT259 has four modes of operation:

- In the addressable latch mode, data on the data line (D) is written into the addressed latch. The addressed latch will follow the data input with all non-addressed latches remaining in their previous states.
- In the memory mode, all latches remain in their previous states and are unaffected by the data or address inputs.
- In the 3-to-8 decoding or demultiplexing mode, the addressed output follows the state of the data input (D) with all other outputs in the LOW state.
- In the reset mode, all outputs are LOW and unaffected by the address inputs (A0 to A2) and data input (D).

When operating the 74AHC259; 74AHCT259 as an address latch, changing more than one bit of the address could impose a transient-wrong address. Therefore, this should only be done while in the memory mode.

## 2. Features

- Balanced propagation delays
- All inputs have Schmitt-trigger actions
- Combines demultiplexer and 8-bit latch
- Serial-to-parallel capability
- Output from each storage bit available
- Random (addressable) data entry
- Easily expandable
- Common reset input
- Useful as a 3-to-8 active HIGH decoder
- Inputs accept voltages higher than  $V_{CC}$



- Input levels:
  - ◆ For 74AHC259: CMOS level
  - ◆ For 74AHCT259: TTL level
- ESD protection:
  - ◆ HBM EIA/JESD22-A114E exceeds 2000 V
  - ◆ MM EIA/JESD22-A115-A exceeds 200 V
  - ◆ CDM EIA/JESD22-C101C exceeds 1000 V
- Multiple package options
- Specified from -40 °C to +85 °C and from -40 °C to +125 °C

### 3. Ordering information

Table 1. Ordering information

Type number	Package			Version
	Temperature range	Name	Description	
<b>74AHC259</b>				
74AHC259D	-40 °C to +125 °C	SO16	plastic small outline package; 16 leads; body width 3.9 mm	SOT109-1
74AHC259PW	-40 °C to +125 °C	TSSOP16	plastic thin shrink small outline package; 16 leads; body width 4.4 mm	SOT403-1
<b>74AHCT259</b>				
74AHCT259D	-40 °C to +125 °C	SO16	plastic small outline package; 16 leads; body width 3.9 mm	SOT109-1
74AHCT259PW	-40 °C to +125 °C	TSSOP16	plastic thin shrink small outline package; 16 leads; body width 4.4 mm	SOT403-1

### 4. Functional diagram

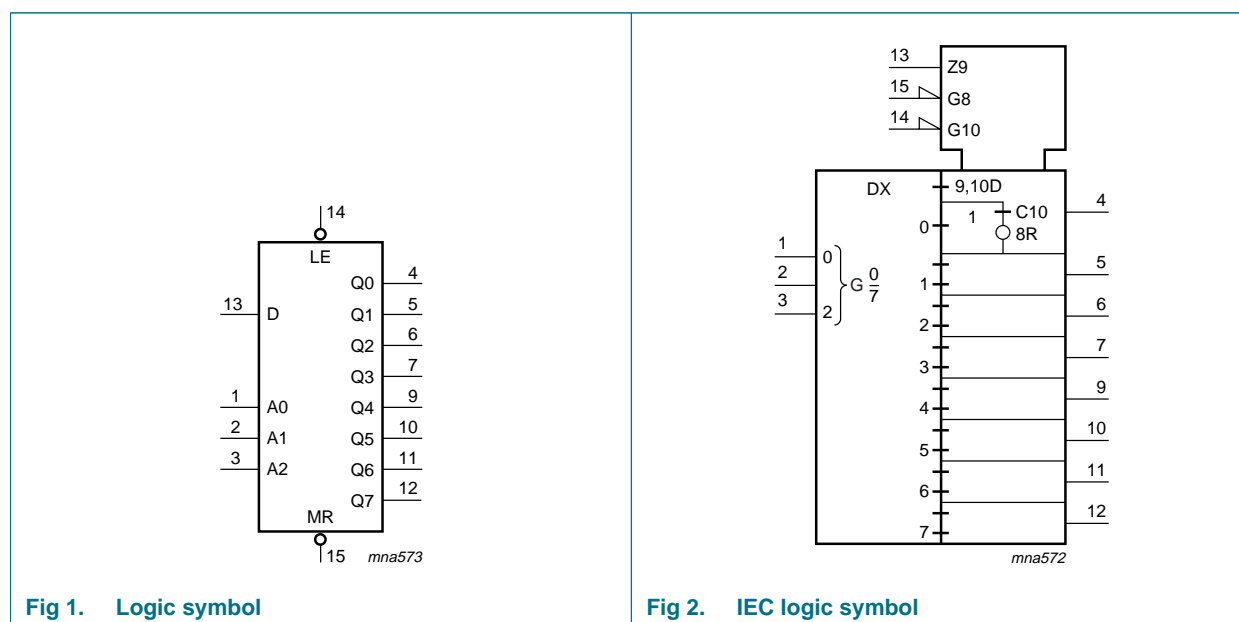

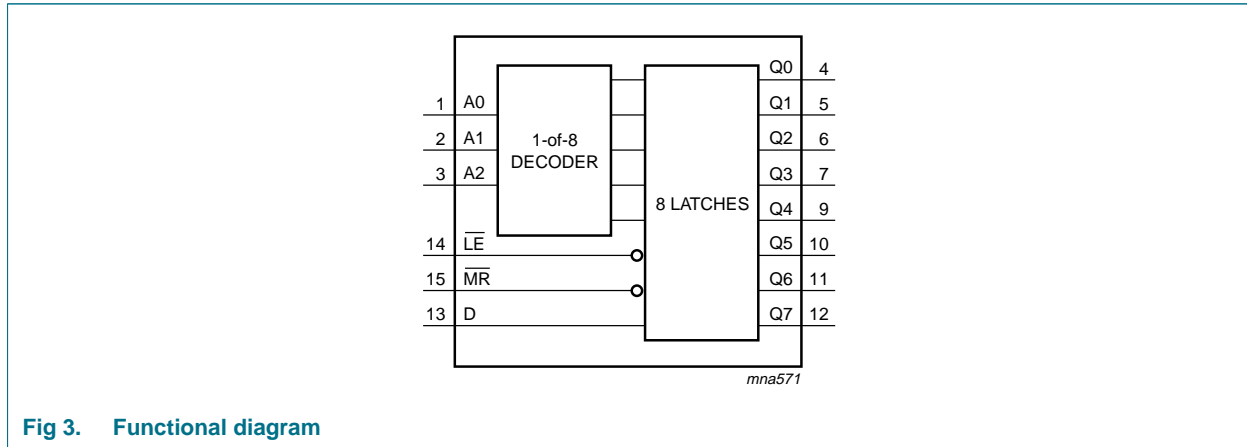

Fig 3. Functional diagram

## 5. Pinning information

### 5.1 Pinning

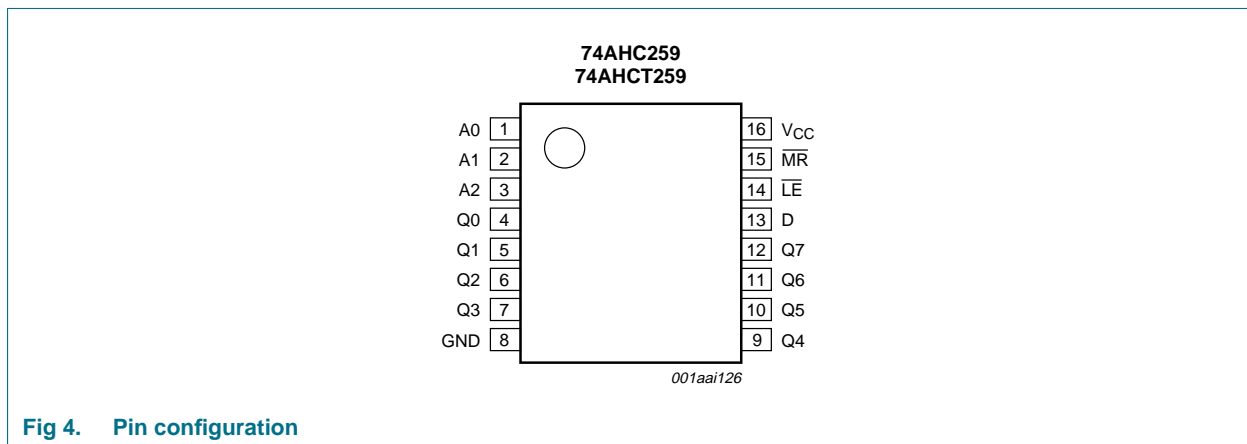

Fig 4. Pin configuration

### 5.2 Pin description

Table 2. Pin description

Symbol	Pin	Description
A0	1	address input
A1	2	address input
A2	3	address input
Q0	4	latch output
Q1	5	latch output
Q2	6	latch output
Q3	7	latch output
GND	8	ground (0 V)
Q4	9	latch output
Q5	10	latch output

Table 2. Pin description ...continued

Symbol	Pin	Description
Q6	11	latch output
Q7	12	latch output
D	13	data input
$\overline{LE}$	14	latch enable input (active LOW)
$\overline{MR}$	15	conditional reset input (active LOW)
V <sub>CC</sub>	16	supply voltage

## 6. Functional description

Table 3. Function table<sup>[1]</sup>

Operating mode	Input						Output							
	$\overline{MR}$	$\overline{LE}$	D	A0	A1	A2	Q0	Q1	Q2	Q3	Q4	Q5	Q6	Q7
Reset (clear)	L	H	X	X	X	X	L	L	L	L	L	L	L	L
Demultiplexer (active HIGH 8-channel) decoder (when D = H)	L	L	d	L	L	L	Q = d	L	L	L	L	L	L	L
			d	H	L	L	L	Q = d	L	L	L	L	L	L
			d	L	H	L	L	L	Q = d	L	L	L	L	L
			d	H	H	L	L	L	L	Q = d	L	L	L	L
			d	L	L	H	L	L	L	L	Q = d	L	L	L
			d	H	L	H	L	L	L	L	L	Q = d	L	L
			d	L	H	H	L	L	L	L	L	L	Q = d	L
			d	H	H	H	L	L	L	L	L	L	L	L
Memory (no action)	H	H	X	X	X	X	q <sub>0</sub>	q <sub>1</sub>	q <sub>2</sub>	q <sub>3</sub>	q <sub>4</sub>	q <sub>5</sub>	q <sub>6</sub>	q <sub>7</sub>
Addressable latch	H	L	d	L	L	L	Q = d	q <sub>1</sub>	q <sub>2</sub>	q <sub>3</sub>	q <sub>4</sub>	q <sub>5</sub>	q <sub>6</sub>	q <sub>7</sub>
			d	H	L	L	q <sub>0</sub>	Q = d	q <sub>2</sub>	q <sub>3</sub>	q <sub>4</sub>	q <sub>5</sub>	q <sub>6</sub>	q <sub>7</sub>
			d	L	H	L	q <sub>0</sub>	q <sub>1</sub>	Q = d	q <sub>3</sub>	q <sub>4</sub>	q <sub>5</sub>	q <sub>6</sub>	q <sub>7</sub>
			d	H	H	L	q <sub>0</sub>	q <sub>1</sub>	q <sub>2</sub>	Q = d	q <sub>4</sub>	q <sub>5</sub>	q <sub>6</sub>	q <sub>7</sub>
			d	L	L	H	q <sub>0</sub>	q <sub>1</sub>	q <sub>2</sub>	q <sub>3</sub>	Q = d	q <sub>5</sub>	q <sub>6</sub>	q <sub>7</sub>
			d	H	L	H	q <sub>0</sub>	q <sub>1</sub>	q <sub>2</sub>	q <sub>3</sub>	q <sub>4</sub>	Q = d	q <sub>6</sub>	q <sub>7</sub>
			d	L	H	H	q <sub>0</sub>	q <sub>1</sub>	q <sub>2</sub>	q <sub>3</sub>	q <sub>4</sub>	q <sub>5</sub>	Q = d	q <sub>7</sub>
			H	H	H	H	q <sub>0</sub>	q <sub>1</sub>	q <sub>2</sub>	q <sub>3</sub>	q <sub>4</sub>	q <sub>5</sub>	q <sub>6</sub>	Q = d

[1] H = HIGH voltage level;  
 L = LOW voltage level;  
 X = don't care;  
 d = HIGH or LOW data one set-up time prior to the LOW-to-HIGH  $\overline{LE}$  transition;  
 q = lower case letter indicates the state of the referenced input one set-up time prior to the LOW-to-HIGH transition.

Table 4. Operating mode select table<sup>[1]</sup>

LE	MR	Mode
L	H	addressable latch
H	H	memory
L	L	active HIGH 8-channel demultiplexer
H	L	reset

[1] H = HIGH voltage level; L = LOW voltage level.

## 7. Limiting values

Table 5. Limiting values

In accordance with the Absolute Maximum Rating System (IEC 60134). Voltages are referenced to GND (ground = 0 V).

Symbol	Parameter	Conditions	Min	Max	Unit
V <sub>CC</sub>	supply voltage		-0.5	+7.0	V
V <sub>I</sub>	input voltage		-0.5	+7.0	V
I <sub>IK</sub>	input clamping current	V <sub>I</sub> < -0.5 V	[1] -20	-	mA
I <sub>OK</sub>	output clamping current	V <sub>O</sub> < -0.5 V or V <sub>O</sub> > V <sub>CC</sub> + 0.5 V	[1] -20	+20	mA
I <sub>O</sub>	output current	V <sub>O</sub> = -0.5 V to (V <sub>CC</sub> + 0.5 V)	-25	+25	mA
I <sub>CC</sub>	supply current		-	+75	mA
I <sub>GND</sub>	ground current		-75	-	mA
T <sub>stg</sub>	storage temperature		-65	+150	°C
P <sub>tot</sub>	total power dissipation	T <sub>amb</sub> = -40 °C to +125 °C	[2] -	500	mW

[1] The input and output voltage ratings may be exceeded if the input and output current ratings are observed.

[2] For SO16 packages: above 70 °C the value of P<sub>tot</sub> derates linearly at 8 mW/K.

For TSSOP16 packages: above 60 °C the value of P<sub>tot</sub> derates linearly at 5.5 mW/K.

## 8. Recommended operating conditions

Table 6. Operating conditions

Symbol	Parameter	Conditions	Min	Typ	Max	Unit
<b>74AHC259</b>						
V <sub>CC</sub>	supply voltage		2.0	5.0	5.5	V
V <sub>I</sub>	input voltage		0	-	5.5	V
V <sub>O</sub>	output voltage		0	-	V <sub>CC</sub>	V
T <sub>amb</sub>	ambient temperature		-40	+25	+125	°C
Δt/ΔV	input transition rise and fall rate	V <sub>CC</sub> = 3.0 V to 3.6 V	-	-	100	ns/V
		V <sub>CC</sub> = 4.5 V to 5.5 V	-	-	20	ns/V
<b>74AHCT259</b>						
V <sub>CC</sub>	supply voltage		4.5	5.0	5.5	V
V <sub>I</sub>	input voltage		0	-	5.5	V
V <sub>O</sub>	output voltage		0	-	V <sub>CC</sub>	V
T <sub>amb</sub>	ambient temperature		-40	+25	+125	°C
Δt/ΔV	input transition rise and fall rate	V <sub>CC</sub> = 4.5 V to 5.5 V	-	-	20	ns/V

## 9. Static characteristics

**Table 7. Static characteristics**

At recommended operating conditions; voltages are referenced to GND (ground = 0 V).

Symbol	Parameter	Conditions	25 °C			-40 °C to +85 °C		-40 °C to +125 °C		Unit
			Min	Typ	Max	Min	Max	Min	Max	
<b>74AHC259</b>										
V <sub>IH</sub>	HIGH-level input voltage	V <sub>CC</sub> = 2.0 V	1.5	-	-	1.5	-	1.5	-	V
		V <sub>CC</sub> = 3.0 V	2.1	-	-	2.1	-	2.1	-	V
		V <sub>CC</sub> = 5.5 V	3.85	-	-	3.85	-	3.85	-	V
V <sub>IL</sub>	LOW-level input voltage	V <sub>CC</sub> = 2.0 V	-	-	0.5	-	0.5	-	0.5	V
		V <sub>CC</sub> = 3.0 V	-	-	0.9	-	0.9	-	0.9	V
		V <sub>CC</sub> = 5.5 V	-	-	1.65	-	1.65	-	1.65	V
V <sub>OH</sub>	HIGH-level output voltage	V <sub>I</sub> = V <sub>IH</sub> or V <sub>IL</sub>								
		I <sub>O</sub> = -50 μA; V <sub>CC</sub> = 2.0 V	1.9	2.0	-	1.9	-	1.9	-	V
		I <sub>O</sub> = -50 μA; V <sub>CC</sub> = 3.0 V	2.9	3.0	-	2.9	-	2.9	-	V
		I <sub>O</sub> = -50 μA; V <sub>CC</sub> = 4.5 V	4.4	4.5	-	4.4	-	4.4	-	V
		I <sub>O</sub> = -4.0 mA; V <sub>CC</sub> = 3.0 V	2.58	-	-	2.48	-	2.40	-	V
I <sub>O</sub> = -8.0 mA; V <sub>CC</sub> = 4.5 V	3.94	-	-	3.80	-	3.70	-	V		
V <sub>OL</sub>	LOW-level output voltage	V <sub>I</sub> = V <sub>IH</sub> or V <sub>IL</sub>								
		I <sub>O</sub> = 50 μA; V <sub>CC</sub> = 2.0 V	-	0	0.1	-	0.1	-	0.1	V
		I <sub>O</sub> = 50 μA; V <sub>CC</sub> = 3.0 V	-	0	0.1	-	0.1	-	0.1	V
		I <sub>O</sub> = 50 μA; V <sub>CC</sub> = 4.5 V	-	0	0.1	-	0.1	-	0.1	V
		I <sub>O</sub> = 4.0 mA; V <sub>CC</sub> = 3.0 V	-	-	0.36	-	0.44	-	0.55	V
I <sub>O</sub> = 8.0 mA; V <sub>CC</sub> = 4.5 V	-	-	0.36	-	0.44	-	0.55	V		
I <sub>I</sub>	input leakage current	V <sub>I</sub> = 5.5 V or GND; V <sub>CC</sub> = 0 V to 5.5 V	-	-	0.1	-	1.0	-	2.0	μA
I <sub>CC</sub>	supply current	V <sub>I</sub> = V <sub>CC</sub> or GND; I <sub>O</sub> = 0 A; V <sub>CC</sub> = 5.5 V	-	-	4.0	-	40	-	80	μA
C <sub>I</sub>	input capacitance	V <sub>I</sub> = V <sub>CC</sub> or GND	-	3	10	-	10	-	10	pF
C <sub>O</sub>	output capacitance		-	4	-	-	-	-	-	pF
<b>74AHCT259</b>										
V <sub>IH</sub>	HIGH-level input voltage	V <sub>CC</sub> = 4.5 V to 5.5 V	2.0	-	-	2.0	-	2.0	-	V
V <sub>IL</sub>	LOW-level input voltage	V <sub>CC</sub> = 4.5 V to 5.5 V	-	-	0.8	-	0.8	-	0.8	V
V <sub>OH</sub>	HIGH-level output voltage	V <sub>I</sub> = V <sub>IH</sub> or V <sub>IL</sub> ; V <sub>CC</sub> = 4.5 V								
		I <sub>O</sub> = -50 μA	4.4	4.5	-	4.4	-	4.4	-	V
		I <sub>O</sub> = -8.0 mA	3.94	-	-	3.80	-	3.70	-	V
V <sub>OL</sub>	LOW-level output voltage	V <sub>I</sub> = V <sub>IH</sub> or V <sub>IL</sub> ; V <sub>CC</sub> = 4.5 V								
		I <sub>O</sub> = 50 μA	-	0	0.1	-	0.1	-	0.1	V
		I <sub>O</sub> = 8.0 mA	-	-	0.36	-	0.44	-	0.55	V

**Table 7. Static characteristics ...continued**

At recommended operating conditions; voltages are referenced to GND (ground = 0 V).

Symbol	Parameter	Conditions	25 °C			-40 °C to +85 °C		-40 °C to +125 °C		Unit
			Min	Typ	Max	Min	Max	Min	Max	
$I_I$	input leakage current	$V_I = 5.5 \text{ V}$ or GND; $V_{CC} = 0 \text{ V}$ to 5.5 V	-	-	0.1	-	1.0	-	2.0	$\mu\text{A}$
$I_{CC}$	supply current	$V_I = V_{CC}$ or GND; $I_O = 0 \text{ A}$ ; $V_{CC} = 5.5 \text{ V}$	-	-	4.0	-	40	-	80	$\mu\text{A}$
$\Delta I_{CC}$	additional supply current	per input pin; $V_I = V_{CC} - 2.1 \text{ V}$ ; other pins at $V_{CC}$ or GND; $I_O = 0 \text{ A}$ ; $V_{CC} = 4.5 \text{ V}$ to 5.5 V	-	-	1.35	-	1.5	-	1.5	$\text{mA}$
$C_I$	input capacitance	$V_I = V_{CC}$ or GND	-	3	10	-	10	-	10	$\text{pF}$
$C_O$	output capacitance		-	4	-	-	-	-	-	$\text{pF}$

## 10. Dynamic characteristics

**Table 8. Dynamic characteristics**Voltages are referenced to GND (ground = 0 V); for test circuit see [Figure 11](#).

Symbol	Parameter	Conditions	25 °C			-40 °C to +85 °C		-40 °C to +125 °C		Unit
			Min	Typ <sup>[1]</sup>	Max	Min	Max	Min	Max	
<b>74AHC259</b>										
$t_{pd}$	propagation delay	D to Qn; see <a href="#">Figure 5</a> <sup>[2]</sup>								
		$V_{CC} = 3.0 \text{ V}$ to 3.6 V								
		$C_L = 15 \text{ pF}$	-	5.8	11.5	1.0	13.5	1.0	15.0	ns
		$C_L = 50 \text{ pF}$	-	7.3	14.5	1.0	17.0	1.0	18.5	ns
		$V_{CC} = 4.5 \text{ V}$ to 5.5 V								
		$C_L = 15 \text{ pF}$	-	4.1	7.5	1.0	9.0	1.0	10.0	ns
		$C_L = 50 \text{ pF}$	-	5.3	9.5	1.0	11.0	1.0	12.0	ns
		An to Qn; see <a href="#">Figure 6</a> <sup>[2]</sup>								
		$V_{CC} = 3.0 \text{ V}$ to 3.6 V								
		$C_L = 15 \text{ pF}$	-	7.5	14.5	1.0	17.0	1.0	18.5	ns
		$C_L = 50 \text{ pF}$	-	9.1	18.0	1.0	21.0	1.0	23.0	ns
		$V_{CC} = 4.5 \text{ V}$ to 5.5 V								
		$C_L = 15 \text{ pF}$	-	5.3	9.5	1.0	11.5	1.0	12.5	ns
		$C_L = 50 \text{ pF}$	-	6.5	11.5	1.0	13.5	1.0	15.0	ns
		$\overline{\text{LE}}$ to Qn; see <a href="#">Figure 7</a> <sup>[2]</sup>								
		$V_{CC} = 3.0 \text{ V}$ to 3.6 V								
$C_L = 15 \text{ pF}$	-	6.2	12.0	1.0	14.0	1.0	15.2	ns		
$C_L = 50 \text{ pF}$	-	7.7	15.5	1.0	17.5	1.0	19.0	ns		
$V_{CC} = 4.5 \text{ V}$ to 5.5 V										
$C_L = 15 \text{ pF}$	-	4.3	8.0	1.0	9.5	1.0	10.5	ns		
$C_L = 50 \text{ pF}$	-	5.5	10.0	1.0	11.5	1.0	12.5	ns		

**Table 8. Dynamic characteristics ...continued**Voltages are referenced to GND (ground = 0 V); for test circuit see [Figure 11](#).

Symbol	Parameter	Conditions	25 °C			-40 °C to +85 °C		-40 °C to +125 °C		Unit	
			Min	Typ <sup>[1]</sup>	Max	Min	Max	Min	Max		
$t_{pd}$	propagation delay	$\overline{MR}$ to Qn; see <a href="#">Figure 8</a> <sup>[3]</sup>									
		$V_{CC} = 3.0\text{ V to }3.6\text{ V}$									
		$C_L = 15\text{ pF}$	-	5.4	10.5	1.0	12.5	1.0	13.5	ns	
		$C_L = 50\text{ pF}$	-	7.0	13.5	1.0	15.5	1.0	17.0	ns	
		$V_{CC} = 4.5\text{ V to }5.5\text{ V}$									
		$C_L = 15\text{ pF}$	-	3.9	7.0	1.0	8.5	1.0	9.5	ns	
$t_w$	pulse width	$\overline{LE}$ HIGH or LOW; see <a href="#">Figure 7</a>									
		$V_{CC} = 3.0\text{ V to }3.6\text{ V}$	5.0	-	-	5.0	-	5.0	-	ns	
		$V_{CC} = 4.5\text{ V to }5.5\text{ V}$	5.0	-	-	5.0	-	5.0	-	ns	
		$\overline{MR}$ LOW; see <a href="#">Figure 8</a>									
		$V_{CC} = 3.0\text{ V to }3.6\text{ V}$	5.0	-	-	5.0	-	5.0	-	ns	
		$V_{CC} = 4.5\text{ V to }5.5\text{ V}$	5.0	-	-	5.0	-	5.0	-	ns	
$t_{su}$	set-up time	D, An to $\overline{LE}$ ; see <a href="#">Figure 9</a> and <a href="#">Figure 10</a>									
		$V_{CC} = 3.0\text{ V to }3.6\text{ V}$	4.0	-	-	4.0	-	4.0	-	ns	
		$V_{CC} = 4.5\text{ V to }5.5\text{ V}$	4.0	-	-	4.0	-	4.0	-	ns	
$t_h$	hold time	D, An to $\overline{LE}$ ; see <a href="#">Figure 9</a> and <a href="#">Figure 10</a>									
		$V_{CC} = 3.0\text{ V to }3.6\text{ V}$	1.0	-	-	1.0	-	1.0	-	ns	
		$V_{CC} = 4.5\text{ V to }5.5\text{ V}$	1.0	-	-	1.0	-	1.0	-	ns	
$C_{PD}$	power dissipation capacitance	$f_i = 1\text{ MHz}; V_I = \text{GND to }V_{CC}$ <sup>[4]</sup>	-	13	-	-	-	-	-	pF	

**74AHCT259;  $V_{CC} = 4.5\text{ V to }5.5\text{ V}$** 

$t_{pd}$	propagation delay	D to Qn; see <a href="#">Figure 5</a> <sup>[2]</sup>								
		$C_L = 15\text{ pF}$	-	4.1	7.5	1.0	9.0	1.0	10.0	ns
		$C_L = 50\text{ pF}$	-	5.4	9.5	1.0	11.0	1.0	12.0	ns
		An to Qn; see <a href="#">Figure 6</a> <sup>[2]</sup>								
		$C_L = 15\text{ pF}$	-	5.5	9.5	1.0	11.5	1.0	12.5	ns
		$C_L = 50\text{ pF}$	-	6.6	12.0	1.0	14.0	1.0	15.5	ns
		$\overline{LE}$ to Qn; see <a href="#">Figure 7</a> <sup>[2]</sup>								
		$C_L = 15\text{ pF}$	-	4.3	8.0	1.0	9.5	1.0	10.4	ns
		$C_L = 50\text{ pF}$	-	5.5	10.0	1.0	12.0	1.0	13.0	ns
		$\overline{MR}$ to Qn; see <a href="#">Figure 8</a> <sup>[3]</sup>								
		$C_L = 15\text{ pF}$	-	3.9	7.0	1.0	8.5	1.0	9.5	ns
		$C_L = 50\text{ pF}$	-	5.1	9.0	1.0	10.5	1.0	11.5	ns
$t_w$	pulse width	$\overline{LE}$ HIGH or LOW; see <a href="#">Figure 7</a>	5.0	-	-	5.0	-	5.0	-	ns
		$\overline{MR}$ LOW; see <a href="#">Figure 8</a>	5.0	-	-	5.0	-	5.0	-	ns



**Table 8. Dynamic characteristics ...continued**

Voltages are referenced to GND (ground = 0 V); for test circuit see [Figure 11](#).

Symbol	Parameter	Conditions	25 °C			-40 °C to +85 °C		-40 °C to +125 °C		Unit
			Min	Typ <sup>[1]</sup>	Max	Min	Max	Min	Max	
t <sub>su</sub>	set-up time	D, An to $\overline{LE}$ ; see <a href="#">Figure 9</a> and <a href="#">Figure 10</a>	4.0	-	-	4.0	-	4.0	-	ns
t <sub>h</sub>	hold time	D, An to $\overline{LE}$ ; see <a href="#">Figure 9</a> and <a href="#">Figure 10</a>	1.0	-	-	1.0	-	1.0	-	ns
C <sub>PD</sub>	power dissipation capacitance	f <sub>i</sub> = 1 MHz; V <sub>I</sub> = GND to V <sub>CC</sub> <sup>[4]</sup>	-	17	-	-	-	-	-	pF

[1] Typical values are measured at nominal supply voltage (V<sub>CC</sub> = 3.3 V and V<sub>CC</sub> = 5.0 V).

[2] t<sub>pd</sub> is the same as t<sub>PLH</sub> and t<sub>PHL</sub>.

[3] t<sub>pd</sub> is the same as t<sub>PHL</sub> only.

[4] C<sub>PD</sub> is used to determine the dynamic power dissipation (P<sub>D</sub> in μW).

$$P_D = C_{PD} \times V_{CC}^2 \times f_i \times N + \Sigma(C_L \times V_{CC}^2 \times f_o) \text{ where:}$$

f<sub>i</sub> = input frequency in MHz;

f<sub>o</sub> = output frequency in MHz;

C<sub>L</sub> = output load capacitance in pF;

V<sub>CC</sub> = supply voltage in V;

N = number of inputs switching;

Σ(C<sub>L</sub> × V<sub>CC</sub><sup>2</sup> × f<sub>o</sub>) = sum of the outputs.

## 11. Waveforms

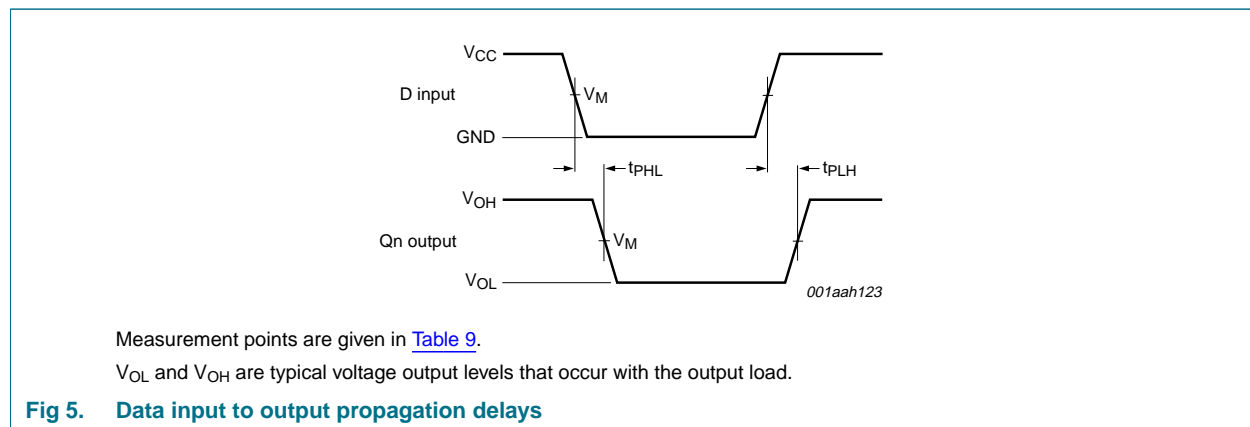

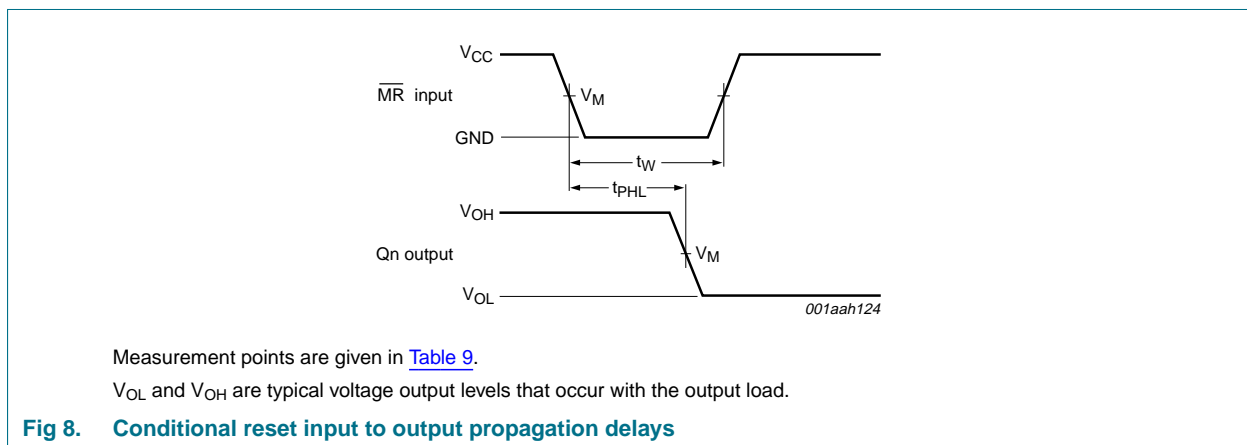
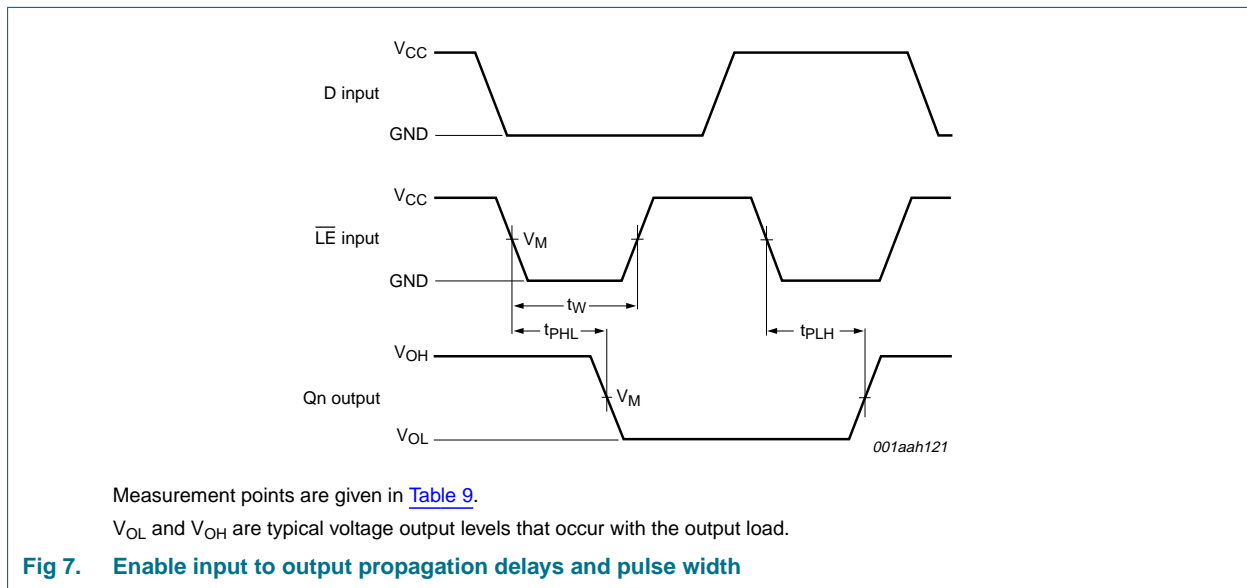
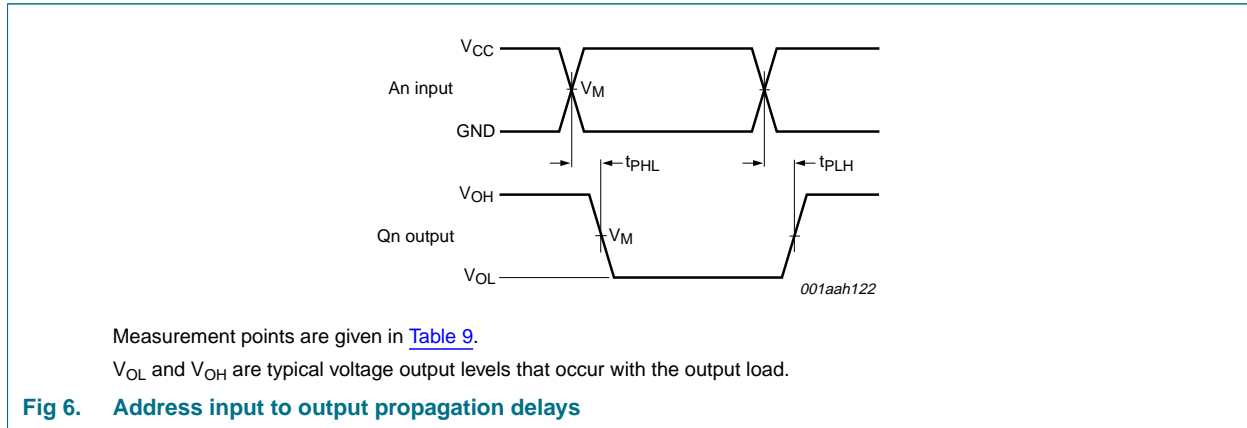

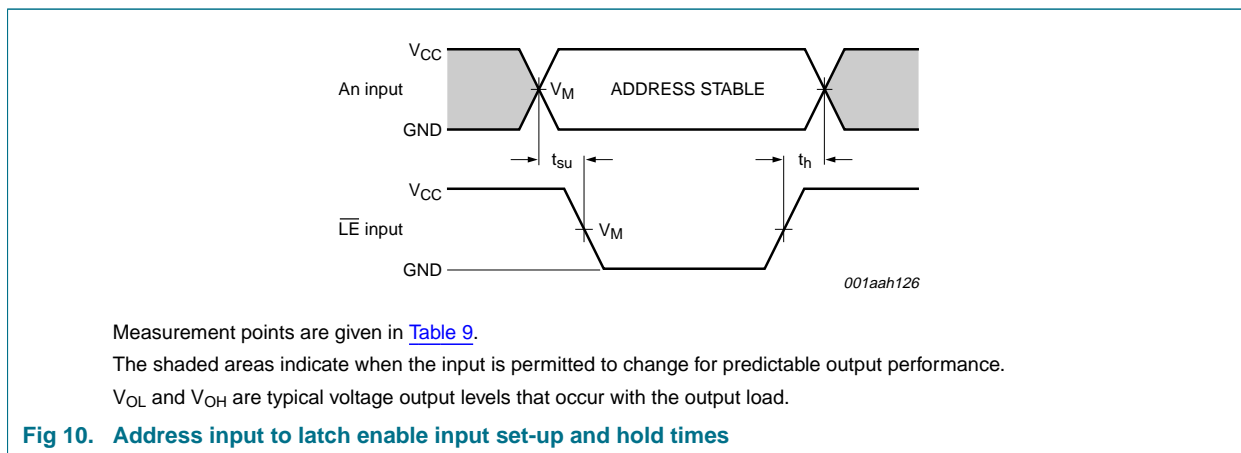
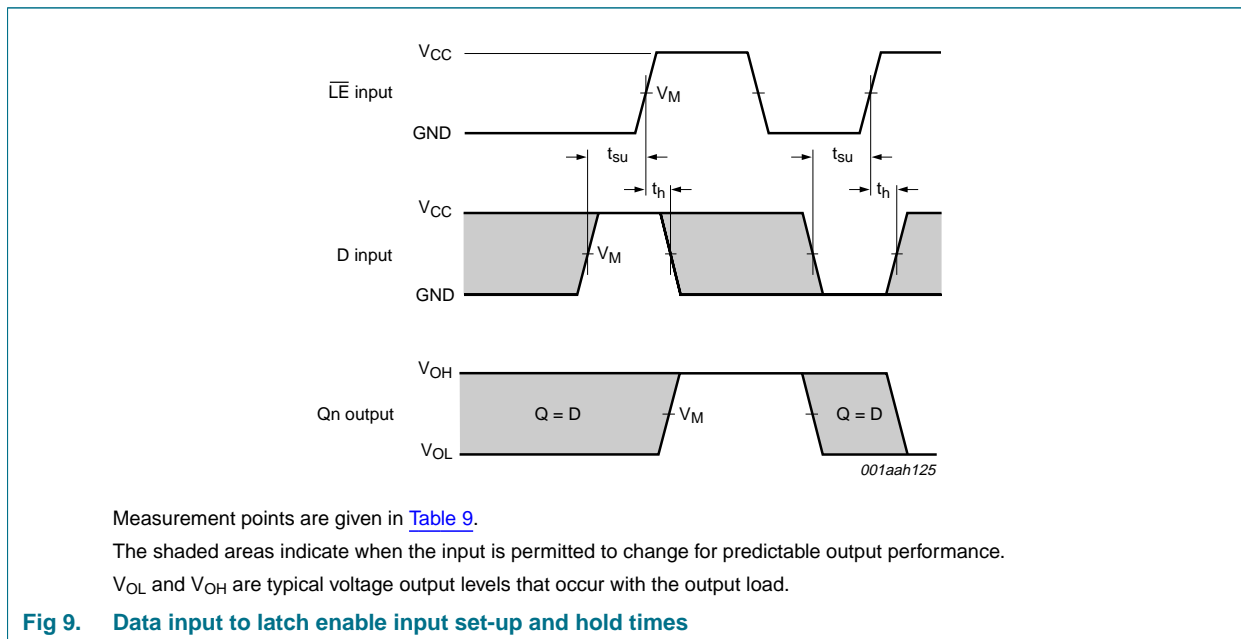

**Table 9. Measurement points**

Type	Input	Output
	$V_M$	$V_M$
74AHC259	$0.5 \times V_{CC}$	$0.5 \times V_{CC}$
74AHCT259	1.5 V	$0.5 \times V_{CC}$

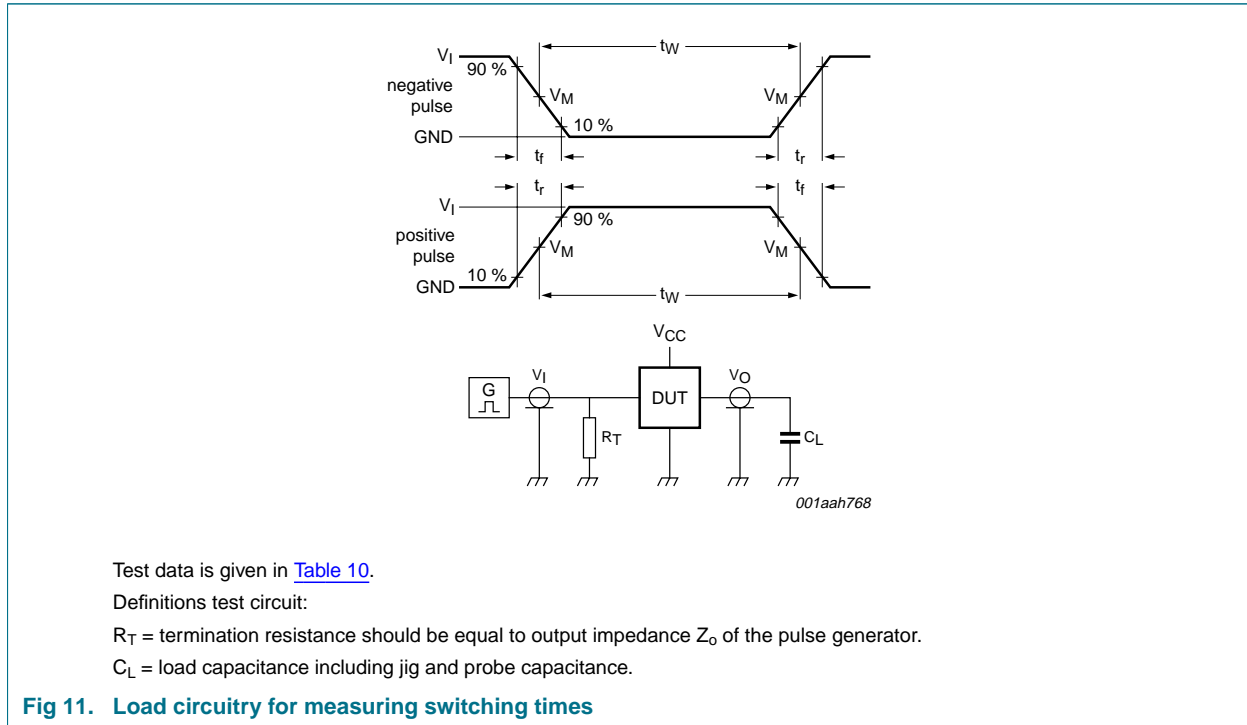

Table 10. Test data

Type	Input		Load	Test
	$V_I$	$t_r, t_f$	$C_L$	
74AHC259	$V_{CC}$	$\leq 3.0$ ns	15 pF, 50 pF	$t_{PLH}, t_{PHL}$
74AHCT259	3.0 V	$\leq 3.0$ ns	15 pF, 50 pF	$t_{PLH}, t_{PHL}$

12. Package outline

SO16: plastic small outline package; 16 leads; body width 3.9 mm

SOT109-1

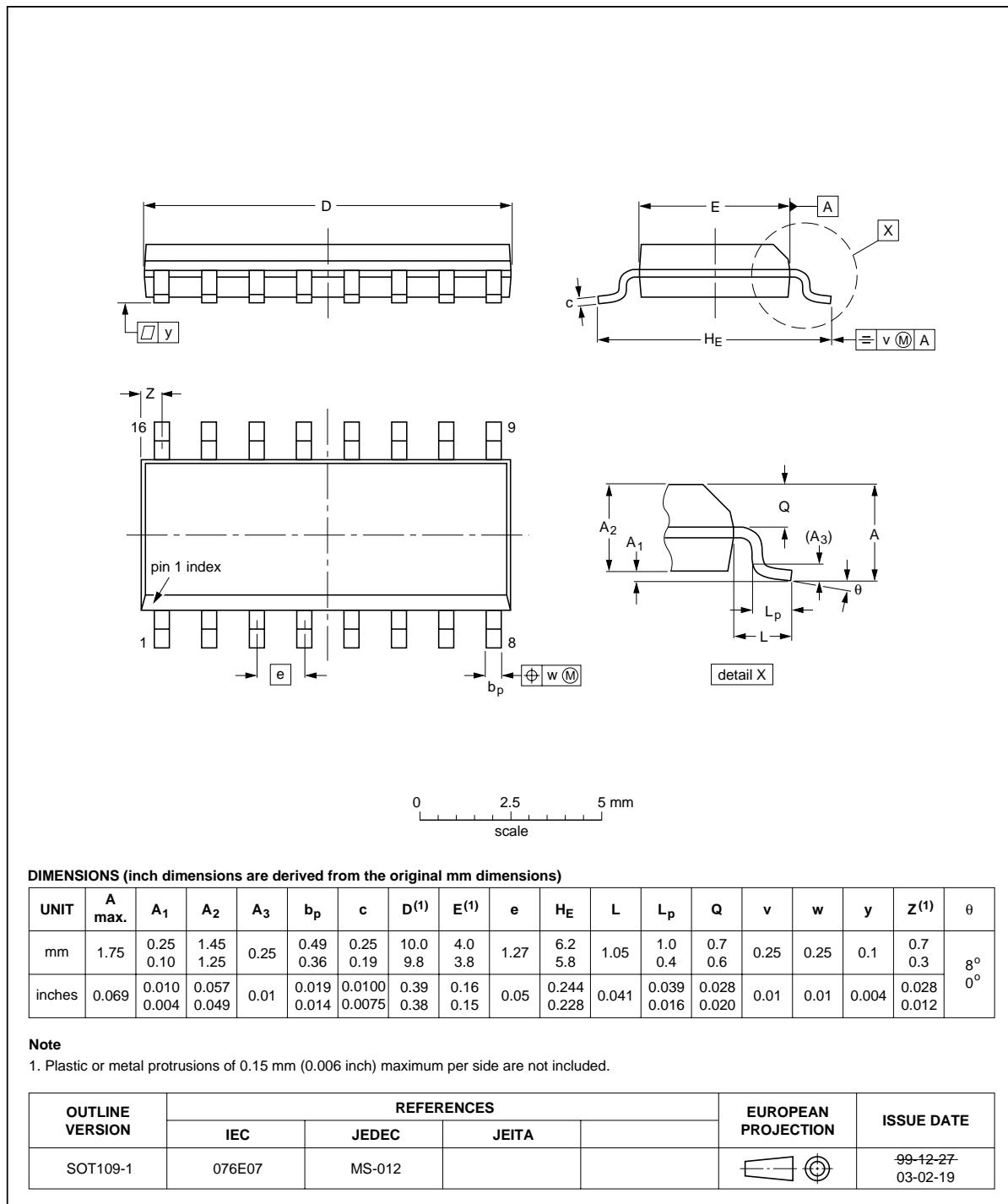

Fig 12. Package outline SOT109-1 (SO16)

TSSOP16: plastic thin shrink small outline package; 16 leads; body width 4.4 mm

SOT403-1

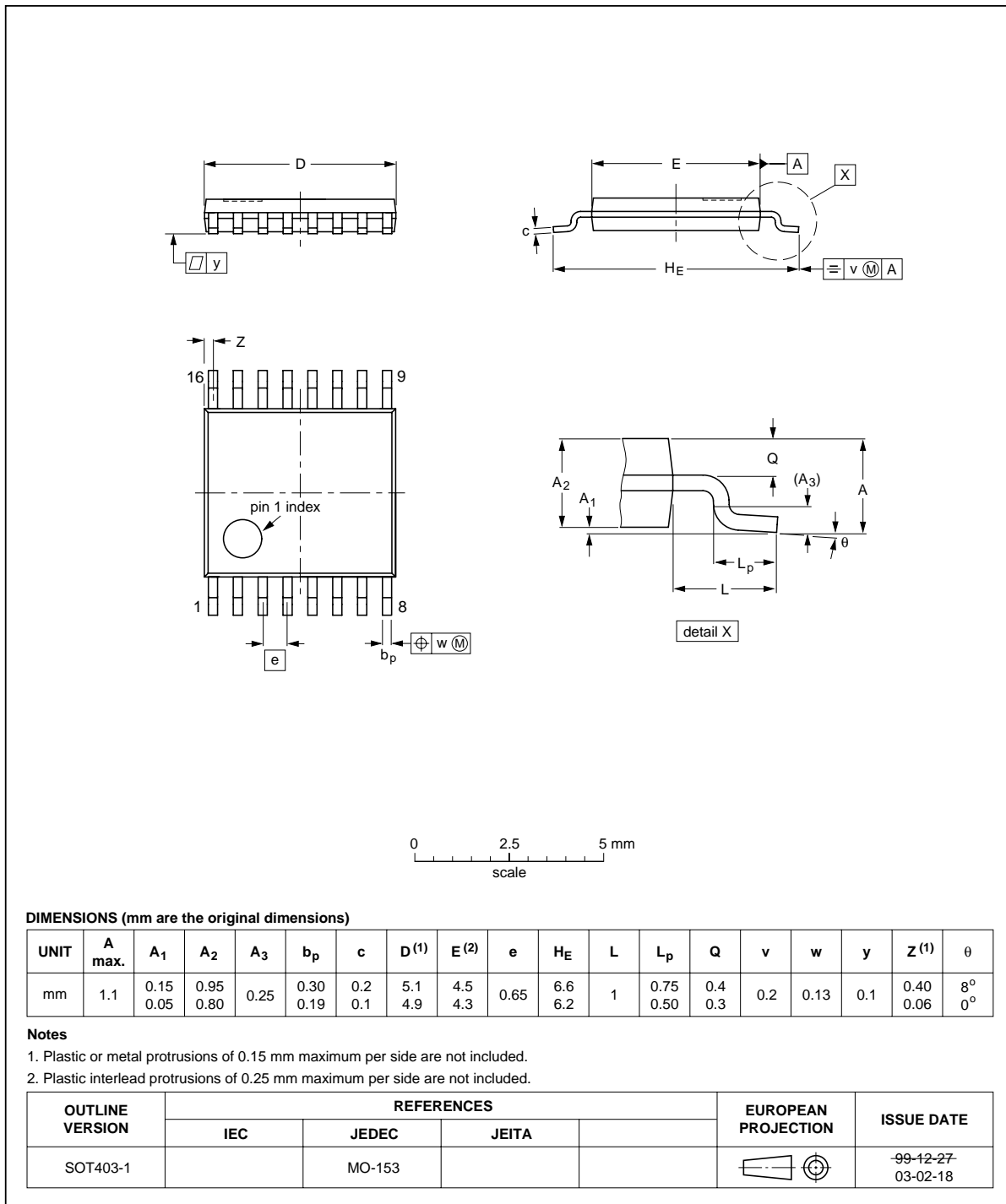

Fig 13. Package outline SOT403-1 (TSSOP16)

## 13. Abbreviations

Table 11. Abbreviations

Acronym	Description
CDM	Charged Device Model
CMOS	Complementary Metal-Oxide Semiconductor
DUT	Device Under Test
ESD	ElectroStatic Discharge
HBM	Human Body Model
LSTTL	Low-power Schottky Transistor-Transistor Logic
MM	Machine Model

## 14. Revision history

Table 12. Revision history

Document ID	Release date	Data sheet status	Change notice	Supersedes
74AHC_AHCT259_2	20080515	Product data sheet	-	74AHC_AHCT259_1
Modifications:	<ul style="list-style-type: none"> <li>The format of this data sheet has been redesigned to comply with the new identity guidelines of NXP Semiconductors.</li> <li>Legal texts have been adapted to the new company name where appropriate.</li> <li><a href="#">Table 6</a>: the conditions for input leakage current have been changed.</li> </ul>			
74AHC_AHCT259_1	20000314	Product specification	-	-

## 15. Legal information

### 15.1 Data sheet status

Document status <sup>[1][2]</sup>	Product status <sup>[3]</sup>	Definition
Objective [short] data sheet	Development	This document contains data from the objective specification for product development.
Preliminary [short] data sheet	Qualification	This document contains data from the preliminary specification.
Product [short] data sheet	Production	This document contains the product specification.

[1] Please consult the most recently issued document before initiating or completing a design.

[2] The term 'short data sheet' is explained in section "Definitions".

[3] The product status of device(s) described in this document may have changed since this document was published and may differ in case of multiple devices. The latest product status information is available on the Internet at URL <http://www.nxp.com>.

### 15.2 Definitions

**Draft** — The document is a draft version only. The content is still under internal review and subject to formal approval, which may result in modifications or additions. NXP Semiconductors does not give any representations or warranties as to the accuracy or completeness of information included herein and shall have no liability for the consequences of use of such information.

**Short data sheet** — A short data sheet is an extract from a full data sheet with the same product type number(s) and title. A short data sheet is intended for quick reference only and should not be relied upon to contain detailed and full information. For detailed and full information see the relevant full data sheet, which is available on request via the local NXP Semiconductors sales office. In case of any inconsistency or conflict with the short data sheet, the full data sheet shall prevail.

### 15.3 Disclaimers

**General** — Information in this document is believed to be accurate and reliable. However, NXP Semiconductors does not give any representations or warranties, expressed or implied, as to the accuracy or completeness of such information and shall have no liability for the consequences of use of such information.

**Right to make changes** — NXP Semiconductors reserves the right to make changes to information published in this document, including without limitation specifications and product descriptions, at any time and without notice. This document supersedes and replaces all information supplied prior to the publication hereof.

**Suitability for use** — NXP Semiconductors products are not designed, authorized or warranted to be suitable for use in medical, military, aircraft, space or life support equipment, nor in applications where failure or

malfunction of an NXP Semiconductors product can reasonably be expected to result in personal injury, death or severe property or environmental damage. NXP Semiconductors accepts no liability for inclusion and/or use of NXP Semiconductors products in such equipment or applications and therefore such inclusion and/or use is at the customer's own risk.

**Applications** — Applications that are described herein for any of these products are for illustrative purposes only. NXP Semiconductors makes no representation or warranty that such applications will be suitable for the specified use without further testing or modification.

**Limiting values** — Stress above one or more limiting values (as defined in the Absolute Maximum Ratings System of IEC 60134) may cause permanent damage to the device. Limiting values are stress ratings only and operation of the device at these or any other conditions above those given in the Characteristics sections of this document is not implied. Exposure to limiting values for extended periods may affect device reliability.

**Terms and conditions of sale** — NXP Semiconductors products are sold subject to the general terms and conditions of commercial sale, as published at <http://www.nxp.com/profile/terms>, including those pertaining to warranty, intellectual property rights infringement and limitation of liability, unless explicitly otherwise agreed to in writing by NXP Semiconductors. In case of any inconsistency or conflict between information in this document and such terms and conditions, the latter will prevail.

**No offer to sell or license** — Nothing in this document may be interpreted or construed as an offer to sell products that is open for acceptance or the grant, conveyance or implication of any license under any copyrights, patents or other industrial or intellectual property rights.

### 15.4 Trademarks

Notice: All referenced brands, product names, service names and trademarks are the property of their respective owners.

## 16. Contact information

For more information, please visit: <http://www.nxp.com>

For sales office addresses, please send an email to: [salesaddresses@nxp.com](mailto:salesaddresses@nxp.com)



## 17. Contents

<b>1</b>	<b>General description</b> . . . . .	<b>1</b>
<b>2</b>	<b>Features</b> . . . . .	<b>1</b>
<b>3</b>	<b>Ordering information</b> . . . . .	<b>2</b>
<b>4</b>	<b>Functional diagram</b> . . . . .	<b>2</b>
<b>5</b>	<b>Pinning information</b> . . . . .	<b>3</b>
5.1	Pinning . . . . .	3
5.2	Pin description . . . . .	3
<b>6</b>	<b>Functional description</b> . . . . .	<b>4</b>
<b>7</b>	<b>Limiting values</b> . . . . .	<b>5</b>
<b>8</b>	<b>Recommended operating conditions</b> . . . . .	<b>5</b>
<b>9</b>	<b>Static characteristics</b> . . . . .	<b>6</b>
<b>10</b>	<b>Dynamic characteristics</b> . . . . .	<b>7</b>
<b>11</b>	<b>Waveforms</b> . . . . .	<b>9</b>
<b>12</b>	<b>Package outline</b> . . . . .	<b>13</b>
<b>13</b>	<b>Abbreviations</b> . . . . .	<b>15</b>
<b>14</b>	<b>Revision history</b> . . . . .	<b>15</b>
<b>15</b>	<b>Legal information</b> . . . . .	<b>16</b>
15.1	Data sheet status . . . . .	16
15.2	Definitions . . . . .	16
15.3	Disclaimers . . . . .	16
15.4	Trademarks . . . . .	16
<b>16</b>	<b>Contact information</b> . . . . .	<b>16</b>
<b>17</b>	<b>Contents</b> . . . . .	<b>17</b>

Please be aware that important notices concerning this document and the product(s) described herein, have been included in section 'Legal information'.



© NXP B.V. 2008.

All rights reserved.

For more information, please visit: <http://www.nxp.com>

For sales office addresses, please send an email to: [salesaddresses@nxp.com](mailto:salesaddresses@nxp.com)

Date of release: 15 May 2008

Document identifier: 74AHC\_AHCT259\_2