

Features;

- * Wide Frequency Bandwidth (1GHz)
- * Ultra Low Phase Noise (less than -90dBc/Hz @1kHz)
- * 1Hz Step Resolution
- * High Purity & Low Spurious Signal Source
- * Frequency Setting Using 3-Wire Serial Interface
- * Built-In PLL Circuit Synchronized with 10MHz External Clock



RoHS Compliant
Directive 2002/95/EC

Function Block Diagram

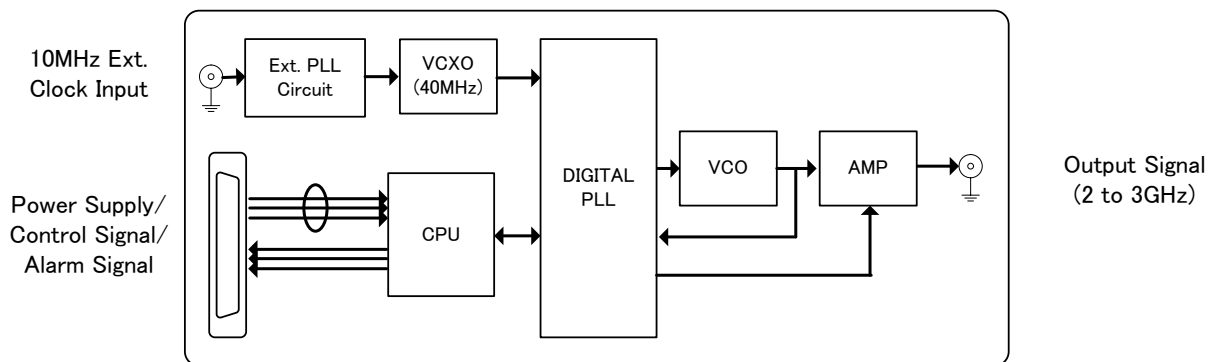

Specifications;

Frequency Range:	2GHz to 3GHz
Bandwidth:	1GHz
Frequency Resolution:	1Hz (3-Wire Serial Interface)
Frequency Stability:	Depends on Ext. Clock
Ext. Clock Input Frequency Range:	10MHz +/- 50Hz
Phase Noise:	< -90dBc/Hz @1kHz
RF Output Power:	14dBm +/- 2dB
Lock-Up Time:	< 150msec
Spurious (Harmonics):	< -30dBc
Spurious (Others):	< -60dBc
Interface:	
RF Output Connector:	SMA-F
Ext. Clock Input Connector:	SMB-F
Power & Control Connector:	DF11-12DP-2DS (HIROSE ELECTRIC CO., LTD.)
Power Supply Voltage(Current Consumption);	Vcc = +12V (< 0.5A)
Operating Temperature Range:	-10 to +60 deg.C
Dimensions: Width(90mm) x Height(19mm) x Depth(110mm)	

Mechanical Outline

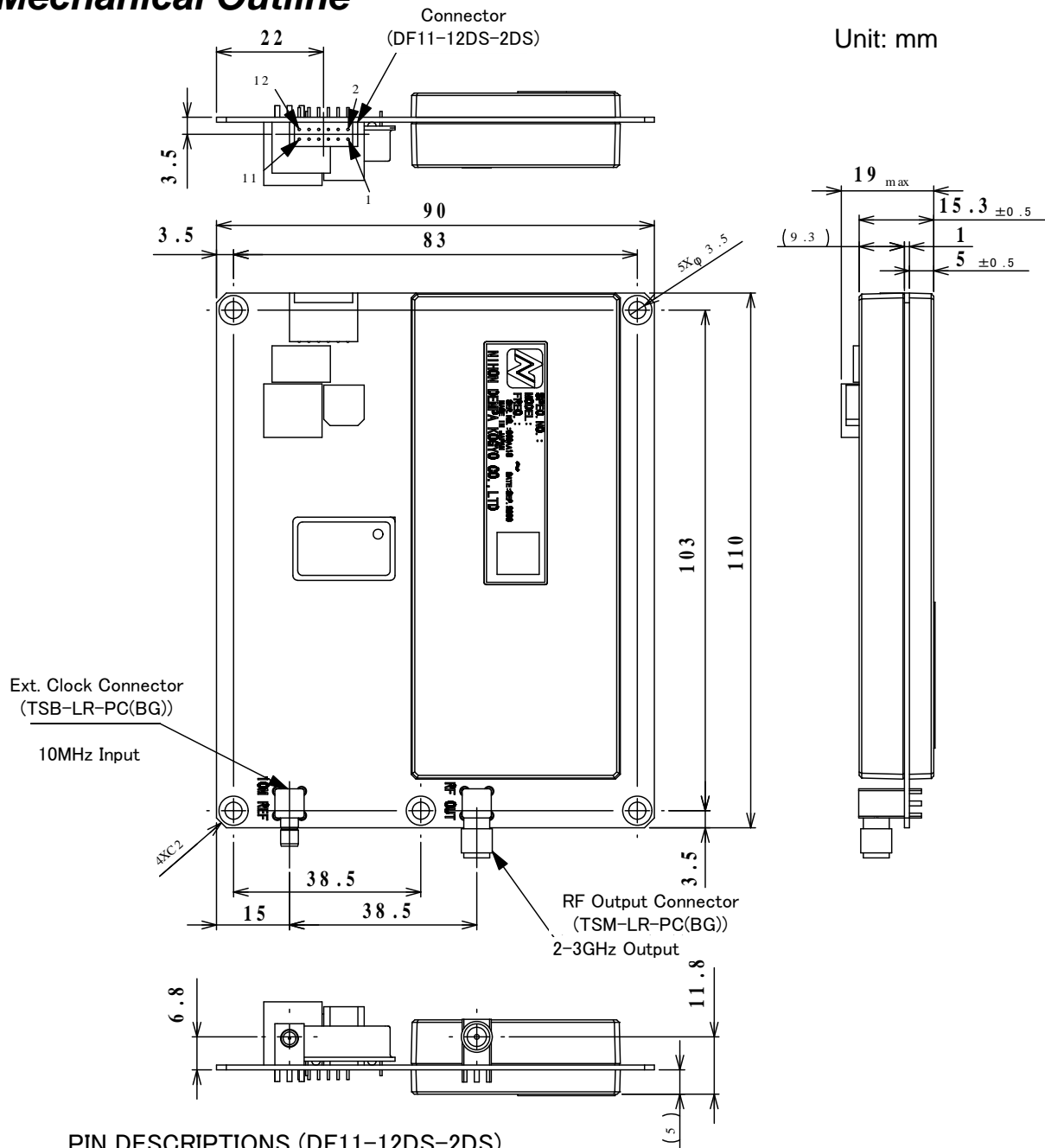

PIN DESCRIPTIONS (DF11-12DS-2DS)

#1	GND		#7	NC	
#2	SDI (SERIAL DATA)	INPUT	#8	RF PLL ALARM	OUTPUT
#3	NC		#9	RF OUTPUT LEVEL ALARM	OUTPUT
#4	10MHz EXT. PLL ALARM	OUTPUT	#10	NC	
#5	/SCS (SERIAL CHIP SELECT)	INPUT	#11	+12V (POWER SUPPLY)	INPUT
#6	SCLK (SERIAL CLOCK)	INPUT	#12	GND	

Notes) Never Connect with NC pins.

Typical Phase Noise Characteristics

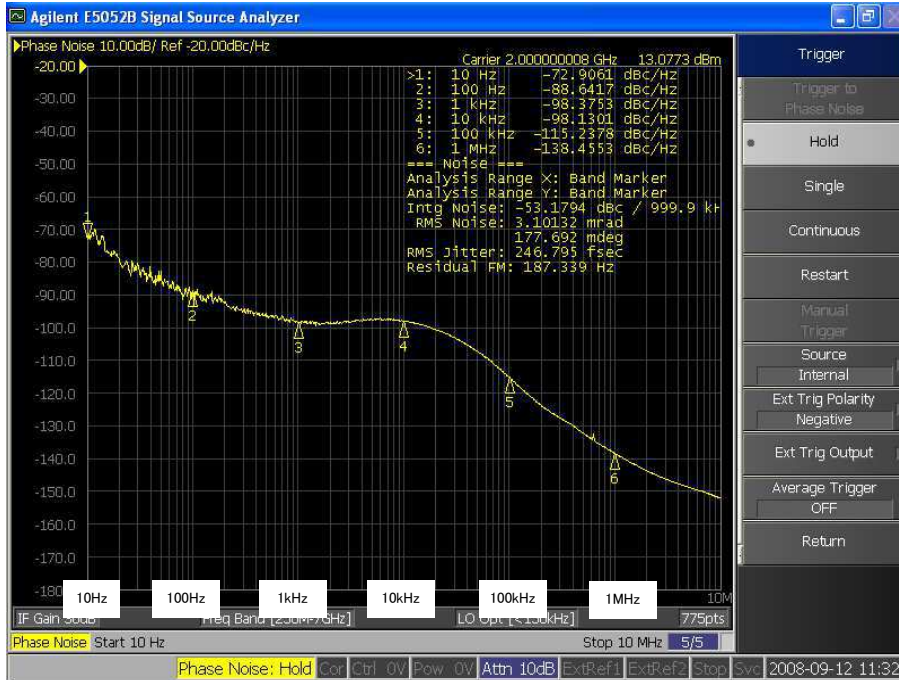

at 2GHz

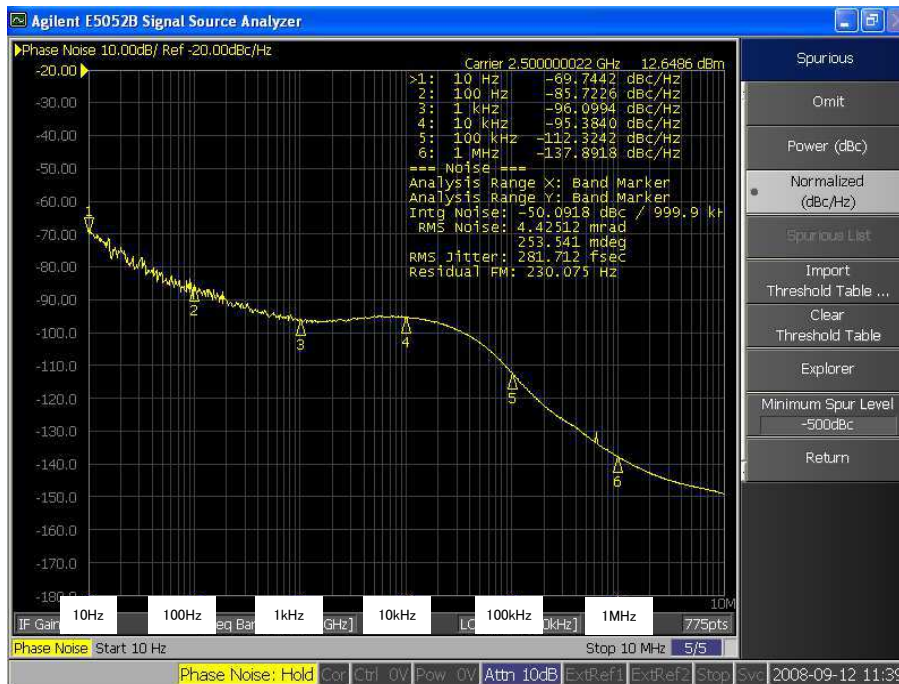

at 2.5GHz

Typical Phase Noise Characteristics

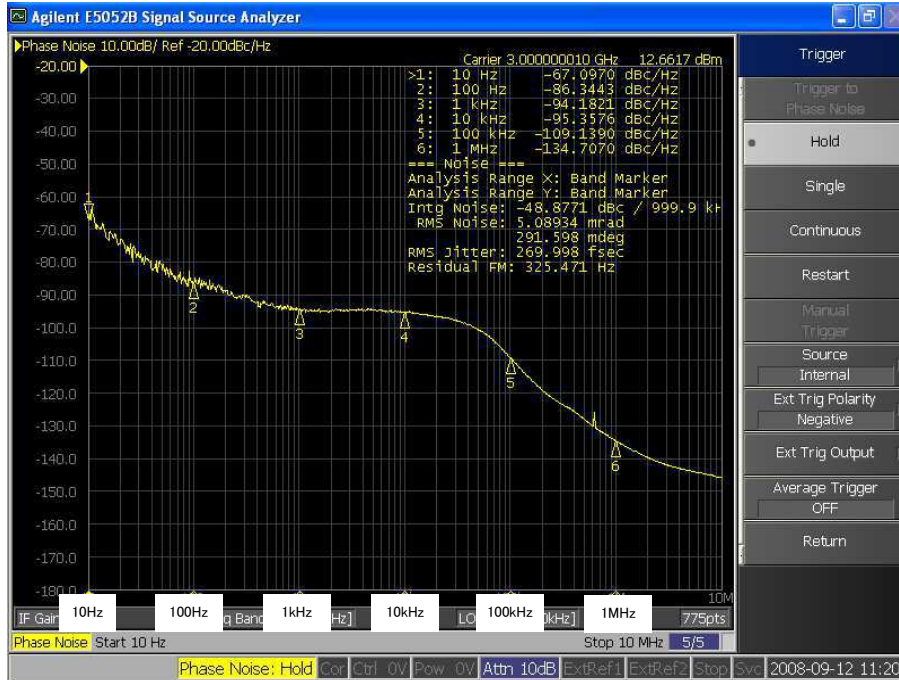

at 3GHz

Typical Output Power

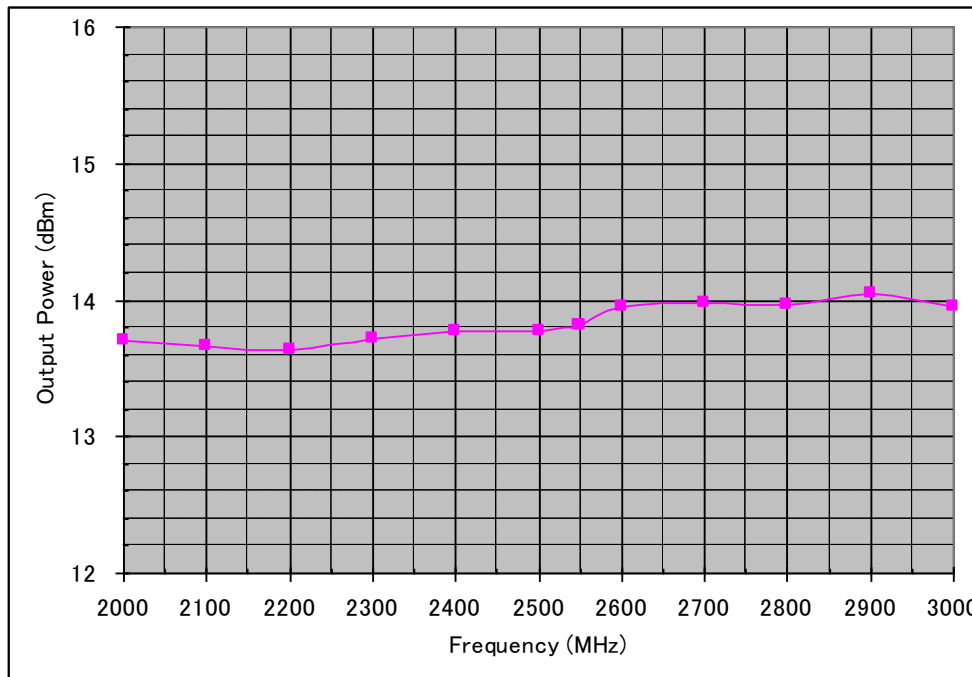

Typical Spurious Characteristics

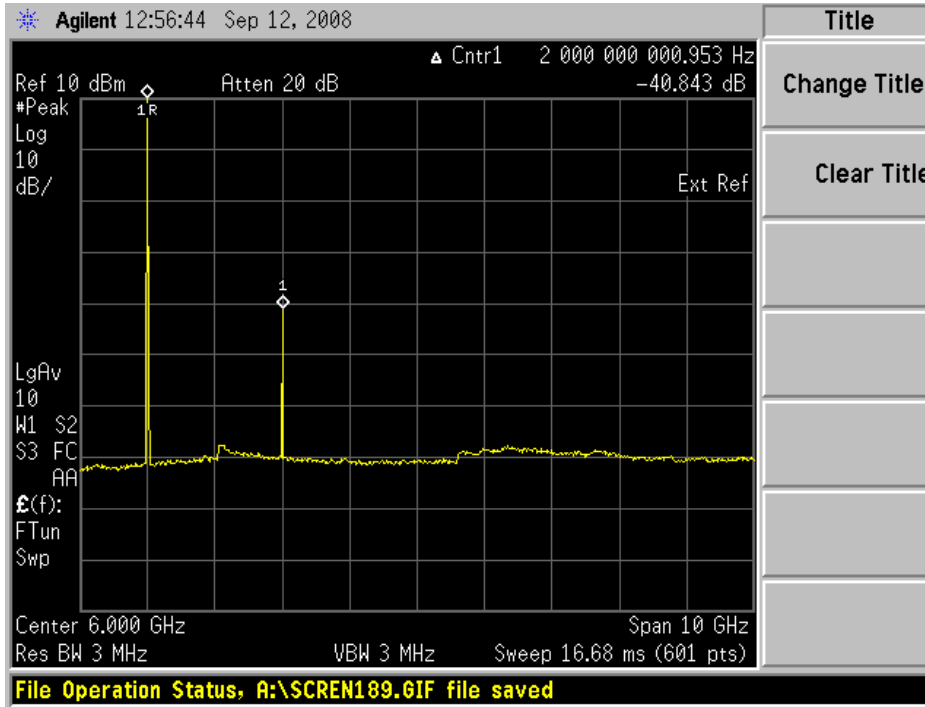

at 2GHz

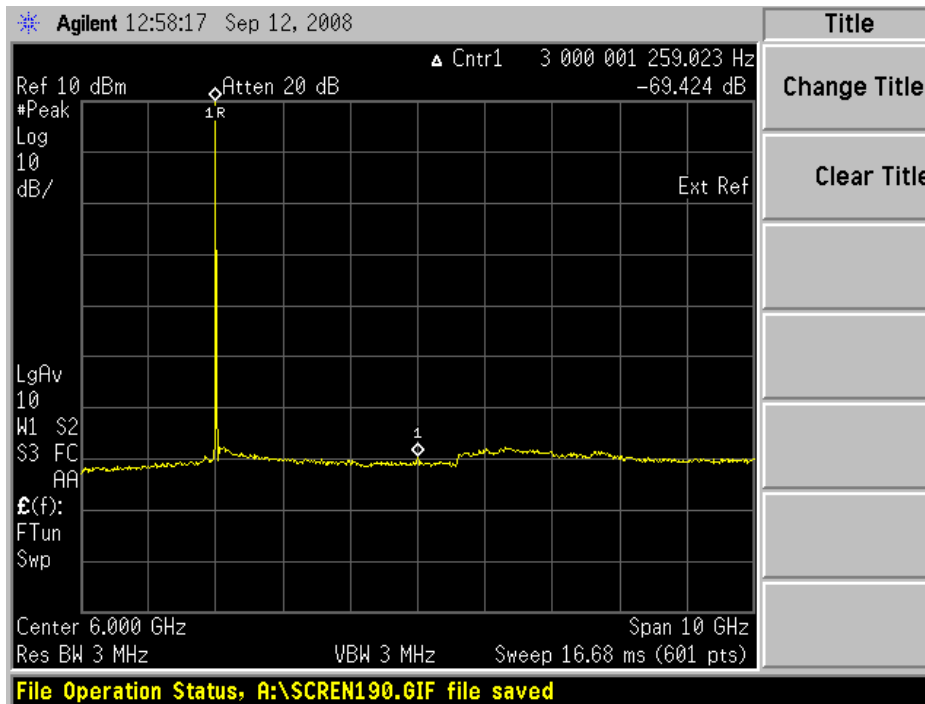

at 3GHz