

#### NGR—New Generation Rocker Switches



4

### Product Description

Eaton presents its New Generation Rocker (NGR) Series. This field-proven line of full-sized rocker switches, initially developed for the heavy truck industry, is now found in a variety of vehicle-related applications.

The NGR offers both European styling and ergonomic design while still providing the solid durability that you have come to expect from Eaton switches.

Illuminated and non-illuminated versions with either incandescent bulbs or LEDs are available in either dependent or independent circuits and in a variety of popular switching circuits.

The NGR also offers a variety of rocker buttons and indicators with laser-etched or pad-printed icons, insertable lenses and adhesive-backed labels.

### Features

- Sealing  
Standard switch provides splash and dust resistance to IP42. The sealed version is sealed to IP67 when supplied with panel seal.
- Rocker  
The standard actuator for the NGR is a clean, European-styled, two-face rocker made of high-quality thermoplastic material. The rocker is replaceable and snaps on and off the switch. Both the rocker and the bezel are supplied with an aesthetically pleasing matte finish. Different colors are also available, but black is standard. Rockers can be ordered separately.

### Contents

<i>Description</i>	<i>Page</i>
NGR—New Generation Rockers	
Switch Base . . . . .	<b>V11-T4-8</b>
Rocker Buttons/Actuators . . . . .	<b>V11-T4-9</b>
Lens Selection . . . . .	<b>V11-T4-11</b>
NGR Complete Indicators and Indicator Caps . . . . .	<b>V11-T4-12</b>
NGR Indicator Base and Indicator Caps . . . . .	<b>V11-T4-13</b>
Technical Data and Specifications . . . . .	<b>V11-T4-14</b>
Standard Circuit Diagrams . . . . .	<b>V11-T4-15</b>
Dimensions . . . . .	<b>V11-T4-27</b>

### Lighting

Each switch is capable of accommodating two incandescent light bulbs or LEDs for lighting purposes. A lamp or LED can be located at either end of the switch and oriented to be circuit dependent or independent. The incandescent bulbs are front replaceable. Two lamp or LED voltages, 14 Vdc and 28 Vdc, are standard. For additional voltages or colors, consult your local Eaton Sales Representative.

### Standards and Certifications

- Approvable under stringent UL® and CSA® standards
- For information, contact your local Eaton Sales Representative
- RoHS Compliant ①



#### Note

① Visit [www.eaton.com/vcbu](http://www.eaton.com/vcbu) for the most up-to-date list of verified part numbers.

## Options

- Circuits
  - 1PST, 1PDT, 2PST and 2PDT
  - Maintained and momentary action
- Common lamp ground jumper for dual lamp units
- Multiple LEDs for daylight readability
- Additional colors of rockers, mounting bezels and lenses are available
- Special circuits
- Special ratings
- Pad-printed legends on lens, rocker and bezel
- Special lamps and lamp voltages
- Dry circuit capabilities
- Custom back-lit legends available
- Reversing jumpers (internal)

- Gang mounting system, see **Page V11-T4-73**
- Locking rocker with locking feature in UP and/or DOWN positions
- Indicators with laser-etched or insertable lenses, or adhesive labels
- IP67 rated sealed switch
- Polarized lock-on connectors, see **Page V11-T4-72**
  - 28-5637-2 for Packard terminals
  - 28-5940 for AMP terminals
- Panel plug 17-21543
- Replacement bulb catalog number
  - 14V: 28-5901
  - 28V: 28-5909

For more information on additional options, contact your local Eaton Sales Representative.

## Legends

Two legend areas are provided on the ends of each rocker of sufficient size to accommodate two lines consisting of four Helvetica Narrow 12-point characters. Legends may be non-illuminated or illuminated. The NGR offers three styles of illuminated legends.

Single-piece back-lit—Back-lighting is a high-quality automotive/truck industry technique. The legend can appear daylight white or dead-front when non-illuminated but, depending on the back-lit color chosen, will change color when illuminated. Examples of standard back-lit legends are found on **Pages V11-T4-76–V11-T4-88**.

Snap-in lenses—This rocker will have either one or two snap-in lenses in the legend areas. Legends are typically pad-printed on the lens in black or white. Snap-in lenses are available in six standard colors and can be ordered separately.

Label rocker—This rocker has a one-piece adhesive-backed label inserted into a recessed area on the face of the button. Legends can be done in several colors and be illuminated or non-illuminated. Contact your local Eaton Sales Representative for suggested sources.

## Flexible Ordering System

You can order assembled switches or the switch base and actuator separately.

Use the final code in the switch base catalog number, **Page V11-T4-8**, to denote assembly instructions.



To order rocker and switch base assembled, contact your local Eaton Sales Representative.

To order rocker buttons, see **Page V11-T4-9**.

To order lenses, see **Page V11-T4-11**.

To order indicator caps, see **Page V11-T4-13**. For a complete indicator, see **Page V11-T4-12**.

### Catalog Number Selection

#### How To Order—Switch Base

To determine complete catalog number, start with the appropriate base prefix and add the appropriate code letters and/or numbers.

**Example:** NGR 1501 4 B N A 0 N

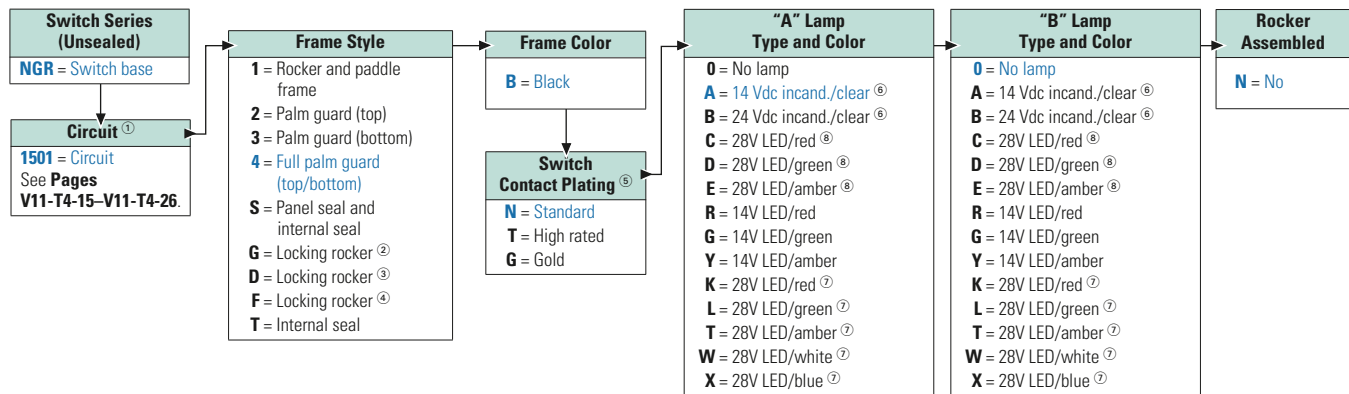

#### Notes

- ① Circuits show lighting options available. See **Pages V11-T4-15–V11-T4-26**.
- ② Locks in DOWN position.
- ③ Locks in UP and DOWN positions.
- ④ Locks in UP position.
- ⑤ Switch contact construction plating—  
 N = Standard: Recommended for use on loads up to 12 amps at 14 Vdc.  
 T = High Rated: Recommended for use on loads greater than 12 amps at 14 Vdc.  
 G = Gold: Recommended for use on dry circuit/low level switching.
- ⑥ Replaceable.
- ⑦ Replaceable/wedge base LED.
- ⑧ PCB version LED.

Rocker Buttons/Actuators



Catalog Number Selection

How To Order—Rocker Buttons/Actuators

To determine complete catalog number, start with the appropriate button type and add the appropriate code letters and/or numbers.

Example: **3 C AF A 1 B AE C 4 A 3**

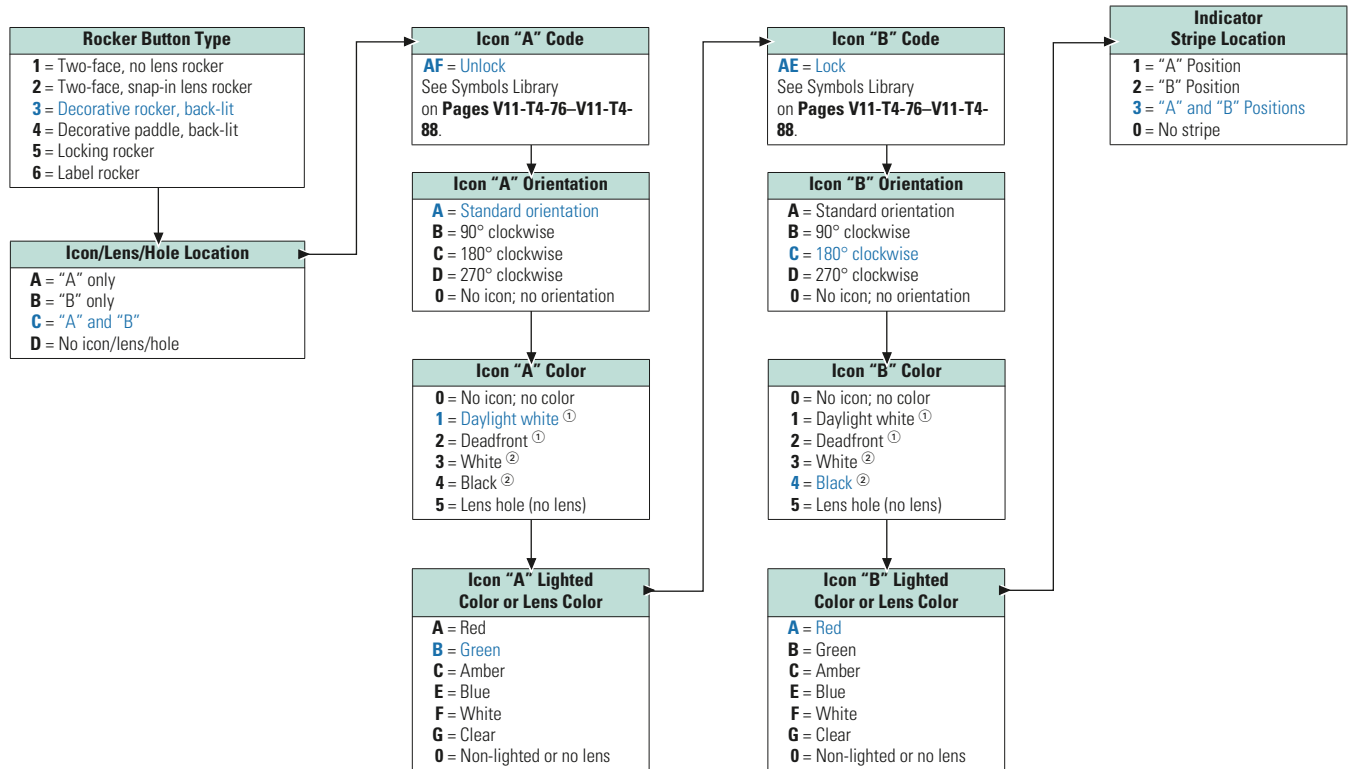

Notes

- ① Decorative rocker only.
- ② Two-face rocker only.

### Icon Location Examples

#### Location A

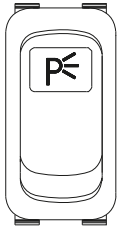

Rocker with Icon in "A" Position (Code A)

#### Location C

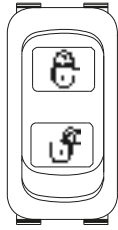

Rocker with Icon in "C" Position (Code C)

#### Location B

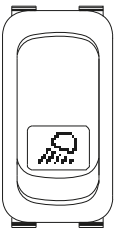

Rocker with Icon in "B" Position (Code B)

### Icon Orientation Examples

#### Orientation A

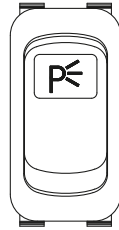

Rocker with Standard Orientation (Code A)

#### Orientation C

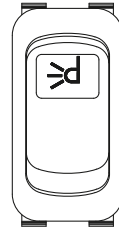

Rocker with Icon at 180° Clockwise (Code C)

#### Orientation B

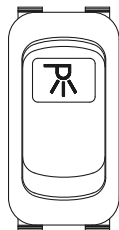

Rocker with Icon at 90° Clockwise (Code B)

#### Orientation D

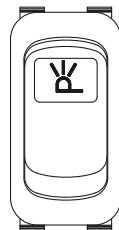

Rocker with Icon at 270° Clockwise (Code D)

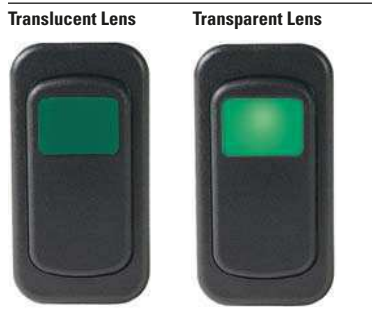

### Lens Selection

For NGR Rocker Type “2” and Indicator Type “2CAP” only.

### Catalog Number Selection

#### How To Order—Translucent Lenses ①②

To determine complete catalog number, start with the appropriate base prefix and add the appropriate code letters and/or numbers.

Example: **28-5863-2 AF A**

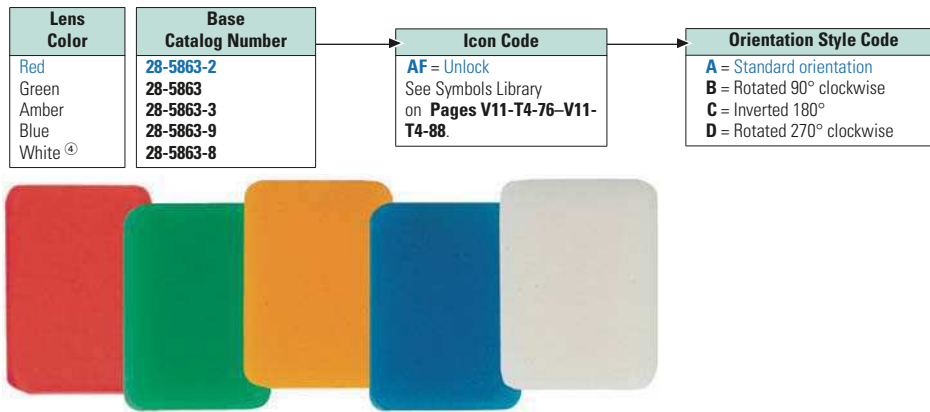

#### How To Order—Transparent Lenses ①②

To determine complete catalog number, start with the appropriate base prefix and add the appropriate code letters and/or numbers.

Example: **28-5863-5 AF A**

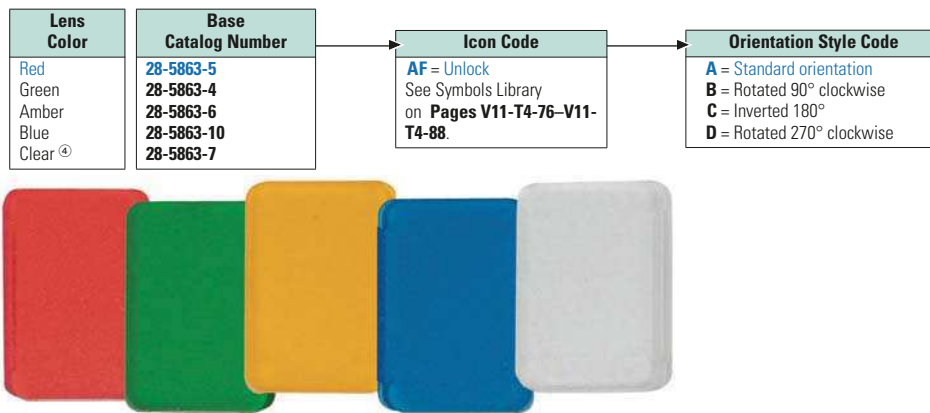

**Notes**

- ① When ordering a lens with an icon for the code **B** (bottom) position, specify code **C** orientation.
- ② Standard lens type.
- ③ Non-standard lens type.
- ④ Standard pad print for white and clear lens is black.

Complete Indicator and Indicator Cap Assembled



4

### NGR Complete Indicators and Indicator Caps

To order rocker buttons, see **Page V11-T4-9**.

To order lenses, see **Page V11-T4-11**.

### Catalog Number Selection

#### How To Order—Complete Indicator

To determine complete catalog number, start with the appropriate indicator type and add the appropriate code letters and/or numbers.

**Example:** 2N C AA R 1 B AB A 0 A

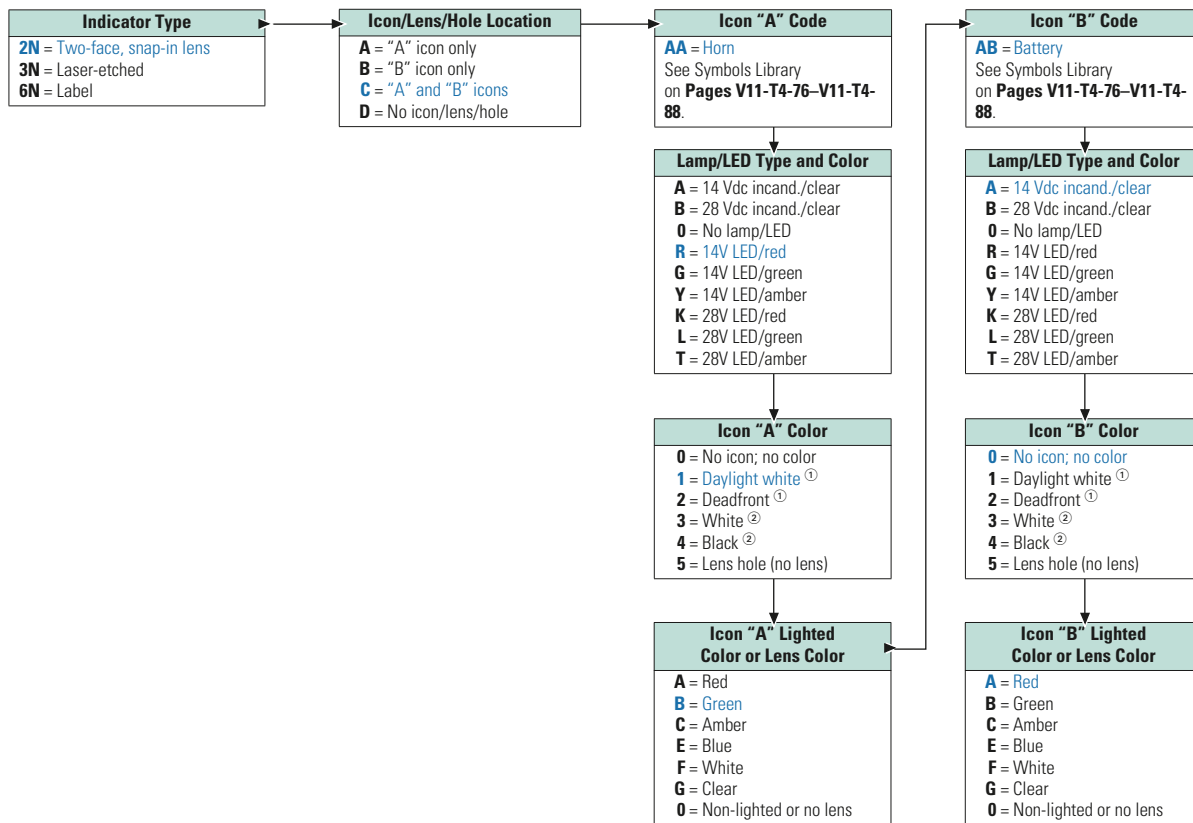

**Notes**

<sup>①</sup> Decorative rocker only.

<sup>②</sup> Two-face rocker only.



### NGR Indicator Base and Indicator Caps

To order rocker buttons, see **Page V11-T4-9**.  
 To order lenses, see **Page V11-T4-11**.  
 To order complete indicator, see **Page V11-T4-12**.

### Catalog Number Selection

#### How To Order—Indicator Base

To determine complete catalog number, start with the appropriate base prefix and add the appropriate code letters and/or numbers.

Example: **NGRIND A 0 N**

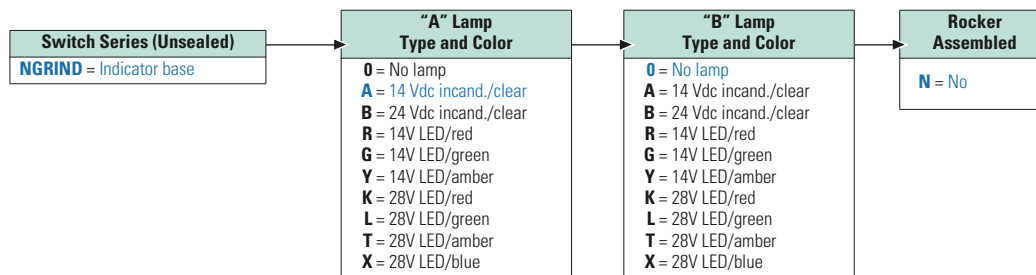

#### How To Order—Indicator Cap

To determine complete catalog number, start with the appropriate indicator type and add the appropriate code letters and/or numbers.

Example: **2CAP C AB 1 B AH 0 A**

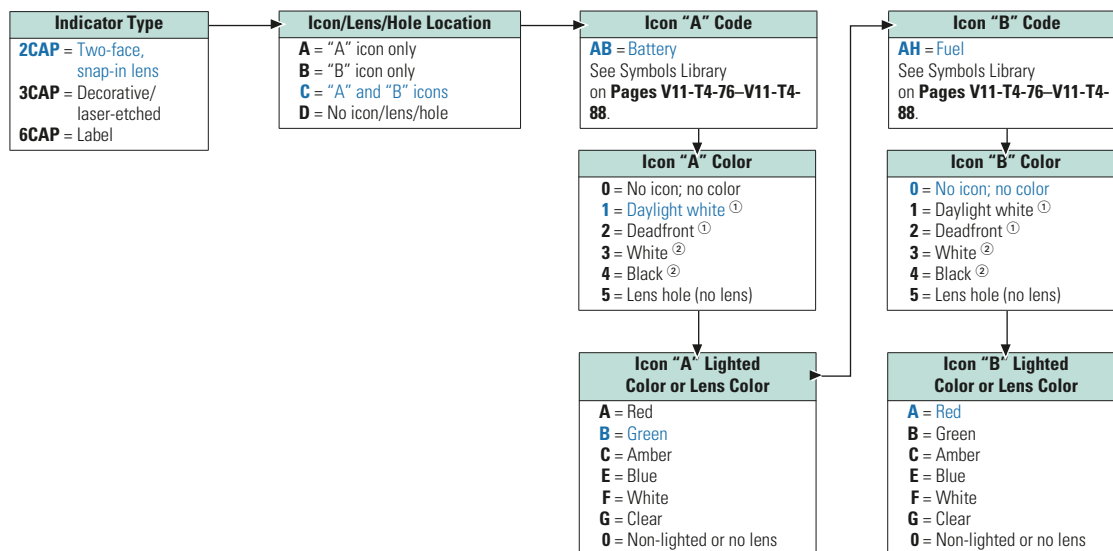

**Notes**

- ① Decorative rocker only.
- ② Two-face rocker only.



## Technical Data and Specifications

### NGR—New Generation Rocker

Description	Specification
Ratings <sup>①</sup>	15A at 125 Vac, 10A at 250 Vac 15A at 28 Vdc (14 Vdc rating) Approvable under stringent UL and CSA standards
Contact mechanism	Slow-make/slow-break contact mechanism Butt action contact mechanism designed specifically for use on AC and low voltage DC applications
Contact material— Standard construction	Movable—copper alloy with silver alloy contact face button Stationary—silver-plated copper alloy with silver alloy contact face button
Mechanical life	250,000 operations, minimum
Electrical life	200,000 operations, minimum
Terminal type	Standard 0.25 in (6.35 mm) spade, silver-plated copper alloy
Base material	High-grade thermoplastic molding material
Dielectric	1000V rms, minimum
Mounting means	Snap-in mounting with plastic bezel
Mounting hole	Rectangular panel cutout 1.734 x 0.867 in (44 x 22 mm)
Panel thickness	0.040 to 0.156 in (1.0 to 4.0 mm) <sup>② ③</sup>
IP rating	Standard IP42; sealed option IP67
Operating temperature range	−40° to 185°F (−40° to 85°C)

#### Notes

- ① For information, contact your local Eaton Sales Representative.
- ② Best results obtained between 0.060 and 0.118 in (1.5 and 3.0 mm).
- ③ On sealed versions, recommended panel thickness between 0.079 and 0.118 in (2.0 and 3.0 mm).

Standard Circuit Diagrams

Single-Pole

Circuit No.	Schematic (Shown in UP Position)	Circuit with Rocker In ...		
		DOWN Position	CENTER Position	UP Position
1001		OFF	NONE	ON
1501		OFF	NONE	ON
1502		OFF	NONE	ON
1503		OFF	NONE	ON
1504		OFF	NONE	ON
1505		OFF	NONE	ON
1506		OFF	NONE	ON
1507		OFF	NONE	ON
1508		OFF	NONE	ON

Two-Pole

Circuit No.	Schematic (Shown in UP Position)	Circuit with Rocker In ...		
		DOWN Position	CENTER Position	UP Position
2001		OFF	NONE	ON
2501		OFF	NONE	ON
2502		OFF	NONE	ON
2503		OFF	NONE	ON
2504		OFF	NONE	ON
2505		OFF	NONE	ON
2506		OFF	NONE	ON
2507		OFF	NONE	ON
2508		OFF	NONE	ON

# 4.2

## Rockers

NGR—New Generation Rockers

### Single-Pole

Circuit No.	Schematic (Shown in UP Position)	Circuit with Rocker In ...		
		DOWN Position	CENTER Position	UP Position
1002		OFF	NONE	MOM. ON 2B-3
1521		OFF	NONE	MOM. ON 2B-3-9
1522		OFF	NONE	MOM. ON 2B-3-10
1523		OFF	NONE	MOM. ON 2B-3
1524		OFF	NONE	MOM. ON 2B-3
1525		OFF	NONE	MOM. ON 2B-3-9
1526		OFF	NONE	MOM. ON 2B-3-10
1528		OFF	NONE	MOM. ON 2B-3

### Two-Pole

Circuit No.	Schematic (Shown in UP Position)	Circuit with Rocker In ...		
		DOWN Position	CENTER Position	UP Position
2002		OFF	NONE	MOM. ON 2B-3 5B-6
2521		OFF	NONE	MOM. ON 2B-3-9 5B-6
2522		OFF	NONE	MOM. ON 2B-3-10 5B-6
2523		OFF	NONE	MOM. ON 2B-3 5B-6
2524		OFF	NONE	MOM. ON 2B-3 5B-6
2525		OFF	NONE	MOM. ON 2B-3-9 5B-6
2526		OFF	NONE	MOM. ON 2B-3-10 5B-6
2528		OFF	NONE	MOM. ON 2B-3 5B-6

Single-Pole

Circuit No.	Schematic (Shown in UP Position)	Circuit with Rocker In ...		
		DOWN Position	CENTER Position	UP Position
1003		ON	NONE	ON
		2B-1	—	2B-3
1541		ON	NONE	ON
		2B-1	—	2B-3-9
1542		ON	NONE	ON
		2B-1	—	2B-3-10
1543		ON	NONE	ON
		2B-1	—	2B-3
1544		ON	NONE	ON
		2B-1	—	2B-3
1545		ON	NONE	ON
		2B-1	—	2B-3-9
1546		ON	NONE	ON
		2B-1	—	2B-3-10
1547		ON	NONE	ON
		2B-1-10	—	2B-3-9
1548		ON	NONE	ON
		2B-1	—	2B-3

Two-Pole

Circuit No.	Schematic (Shown in UP Position)	Circuit with Rocker In ...		
		DOWN Position	CENTER Position	UP Position
2003		ON	NONE	ON
		2B-1 5B-4	—	2B-3 5B-6
2541		ON	NONE	ON
		2B-1 5B-4	—	2B-3-9 5B-6
2542		ON	NONE	ON
		2B-1 5B-4	—	2B-3-10 5B-6
2543		ON	NONE	ON
		2B-1 5B-4	—	2B-3 5B-6
2544		ON	NONE	ON
		2B-1 5B-4	—	2B-3 5B-6
2545		ON	NONE	ON
		2B-1 5B-4	—	2B-3-9 5B-6
2546		ON	NONE	ON
		2B-1 5B-4	—	2B-3-10 5B-6
2547		ON	NONE	ON
		2B-1-10 5B-4	—	2B-3-9 5B-6
2548		ON	NONE	ON
		2B-1 5B-4	—	2B-3 5B-6

# 4.2

## Rockers

### NGR—New Generation Rockers

#### Single-Pole

Circuit No.	Schematic (Shown in UP Position)	Circuit with Rocker In ...		
		DOWN Position	CENTER Position	UP Position
1004		ON	OFF	ON
		2B-1	—	2B-3
1561		ON	OFF	ON
		2B-1	—	2B-3-9
1562		ON	OFF	ON
		2B-1	—	2B-3-10
1563		ON	OFF	ON
		2B-1	—	2B-3
1564		ON	OFF	ON
		2B-1	—	2B-3
1565		ON	OFF	ON
		2B-1	—	2B-3-9
1566		ON	OFF	ON
		2B-1	—	2B-3-10
1567		ON	OFF	ON
		2B-1-10	—	2B-3-9
1568		ON	OFF	ON
		2B-1	—	2B-3

#### Two-Pole

Circuit No.	Schematic (Shown in UP Position)	Circuit with Rocker In ...		
		DOWN Position	CENTER Position	UP Position
2004		ON	OFF	ON
		2B-1	—	2B-3
		5B-4	—	5B-6
2561		ON	OFF	ON
		2B-1	—	2B-3-9
		5B-4	—	5B-6
2562		ON	OFF	ON
		2B-1	—	2B-3-10
		5B-4	—	5B-6
2563		ON	OFF	ON
		2B-1	—	2B-3
		5B-4	—	5B-6
2564		ON	OFF	ON
		2B-1	—	2B-3
		5B-4	—	5B-6
2565		ON	OFF	ON
		2B-1	—	2B-3-9
		5B-4	—	5B-6
2566		ON	OFF	ON
		2B-1	—	2B-3-10
		5B-4	—	5B-6
2567		ON	OFF	ON
		2B-1-10	—	2B-3-9
		5B-4	—	5B-6
2568		ON	OFF	ON
		2B-1	—	2B-3
		5B-4	—	5B-6

Single-Pole

Circuit No.	Schematic (Shown in UP Position)	Circuit with Rocker In ...		
		DOWN Position	CENTER Position	UP Position
1005		MOM. ON	OFF	MOM. ON
		2B-1	—	2B-3
1581		MOM. ON	OFF	MOM. ON
		2B-1	—	2B-3-9
1582		MOM. ON	OFF	MOM. ON
		2B-1	—	2B-3-10
1583		MOM. ON	OFF	MOM. ON
		2B-1	—	2B-3
1584		MOM. ON	OFF	MOM. ON
		2B-1	—	2B-3
1585		MOM. ON	OFF	MOM. ON
		2B-1	—	2B-3-9
1586		MOM. ON	OFF	MOM. ON
		2B-1	—	2B-3-10
1587		MOM. ON	OFF	MOM. ON
		2B-1-10	—	2B-3-9
1588		MOM. ON	OFF	MOM. ON
		2B-1	—	2B-3

Two-Pole

Circuit No.	Schematic (Shown in UP Position)	Circuit with Rocker In ...		
		DOWN Position	CENTER Position	UP Position
2005		MOM. ON	OFF	MOM. ON
		2B-1	—	2B-3
		5B-4	—	5B-6
2581		MOM. ON	OFF	MOM. ON
		2B-1	—	2B-3-9
		5B-4	—	5B-6
2582		MOM. ON	OFF	MOM. ON
		2B-1	—	2B-3-10
		5B-4	—	5B-6
2583		MOM. ON	OFF	MOM. ON
		2B-1	—	2B-3
		5B-4	—	5B-6
2584		MOM. ON	OFF	MOM. ON
		2B-1	—	2B-3
		5B-4	—	5B-6
2585		MOM. ON	OFF	MOM. ON
		2B-1	—	2B-3-9
		5B-4	—	5B-6
2586		MOM. ON	OFF	MOM. ON
		2B-1	—	2B-3-10
		5B-4	—	5B-6
2587		MOM. ON	OFF	MOM. ON
		2B-1-10	—	2B-3-9
		5B-4	—	5B-6
2588		MOM. ON	OFF	MOM. ON
		2B-1	—	2B-3
		5B-4	—	5B-6

### Single-Pole

Circuit No.	Schematic (Shown in UP Position)	Circuit with Rocker In ...		
		DOWN Position	CENTER Position	UP Position
1006		ON	OFF	MOM. ON
		2B-1	—	2B-3
1601		ON	OFF	MOM. ON
		2B-1	—	2B-3-9
1602		ON	OFF	MOM. ON
		2B-1	—	2B-3-10
1603		ON	OFF	MOM. ON
		2B-1	—	2B-3
1604		ON	OFF	MOM. ON
		2B-1	—	2B-3
1605		ON	OFF	MOM. ON
		2B-1	—	2B-3-9
1606		ON	OFF	MOM. ON
		2B-1	—	2B-3-10
1607		ON	OFF	MOM. ON
		2B-1-10	—	2B-3-9
1608		ON	OFF	MOM. ON
		2B-1	—	2B-3

### Two-Pole

Circuit No.	Schematic (Shown in UP Position)	Circuit with Rocker In ...		
		DOWN Position	CENTER Position	UP Position
2006		ON	OFF	MOM. ON
		2B-1	—	2B-3
		5B-4	—	5B-6
2601		ON	OFF	MOM. ON
		2B-1	—	2B-3-9
		5B-4	—	5B-6
2602		ON	OFF	MOM. ON
		2B-1	—	2B-3-10
		5B-4	—	5B-6
2603		ON	OFF	MOM. ON
		2B-1	—	2B-3
		5B-4	—	5B-6
2604		ON	OFF	MOM. ON
		2B-1	—	2B-3
		5B-4	—	5B-6
2605		ON	OFF	MOM. ON
		2B-1	—	2B-3-9
		5B-4	—	5B-6
2606		ON	OFF	MOM. ON
		2B-1	—	2B-3-10
		5B-4	—	5B-6
2607		ON	OFF	MOM. ON
		2B-1-10	—	2B-3-9
		5B-4	—	5B-6
2608		ON	OFF	MOM. ON
		2B-1	—	2B-3
		5B-4	—	5B-6

Single-Pole

Circuit No.	Schematic (Shown in UP Position)	Circuit with Rocker In ...		
		DOWN Position	CENTER Position	UP Position
3003		OFF	ON	ON
		2A-1	2A-2B	2B-3
3541		OFF	ON	ON
		2A-1	2A-2B	2B-3-9
3542		OFF	ON	ON
		2A-1	2A-2B	2B-3-10
3543		OFF	ON	ON
		2A-1	2A-2B	2B-3
3544		OFF	ON	ON
		2A-1	2A-2B	2B-3
3545		OFF	ON	ON
		2A-1	2A-2B	2B-3-9
3546		OFF	ON	ON
		2A-1	2A-2B	2B-3-10
3547		OFF	ON	ON
		2A-1-10	2A-2B	2B-3-9
3548		OFF	ON	ON
		2A-1	2A-2B	2B-3

Two-Pole

Circuit No.	Schematic (Shown in UP Position)	Circuit with Rocker In ...		
		DOWN Position	CENTER Position	UP Position
3004		OFF	ON	ON
		2A-1	2A-2B	2B-3
		5A-4	5A-5B	5B-6
3561		OFF	ON	ON
		2A-1	2A-2B	2B-3-9
		5A-4	5A-5B	5B-6
3562		OFF	ON	ON
		2A-1	2A-2B	2B-3-10
		5A-4	5A-5B	5B-6
3563		OFF	ON	ON
		2A-1	2A-2B	2B-3
		5A-4	5A-5B	5B-6
3564		OFF	ON	ON
		2A-1	2A-2B	2B-3
		5A-4	5A-5B	5B-6
3565		OFF	ON	ON
		2A-1	2A-2B	2B-3-9
		5A-4	5A-5B	5B-6
3566		OFF	ON	ON
		2A-1	2A-2B	2B-3-10
		5A-4	5A-5B	5B-6
3567		OFF	ON	ON
		2A-1-10	2A-2B	2B-3-9
		5A-4	5A-5B	5B-6
3568		OFF	ON	ON
		2A-1	2A-2B	2B-3
		5A-4	5A-5B	5B-6



# 4.2

## Rockers

### NGR—New Generation Rockers

#### Single-Pole

Circuit No.	Schematic (Shown in UP Position)	Circuit with Rocker In ...		
		DOWN Position	CENTER Position	UP Position
5001		ON	NONE	OFF
		2B-1	—	—
5501		ON	NONE	OFF
		2B-1-9	—	—
5502		ON	NONE	OFF
		2B-1-10	—	—
5503		ON	NONE	OFF
		2B-1	—	—
5504		ON	NONE	OFF
		2B-1	—	—
5505		ON	NONE	OFF
		2B-1-9	—	—
5506		ON	NONE	OFF
		2B-1-10	—	—
5507		ON	NONE	OFF
		2B-1-9-10	—	—
5508		ON	NONE	OFF
		2B-1	—	—

#### Two-Pole

Circuit No.	Schematic (Shown in UP Position)	Circuit with Rocker In ...		
		DOWN Position	CENTER Position	UP Position
5510		ON	NONE	OFF
		2B-1 5B-4	—	—
5511		ON	NONE	OFF
		2B-1-9 5B-4	—	—
5512		ON	NONE	OFF
		2B-1-10 5B-4	—	—
5513		ON	NONE	OFF
		2B-1 5B-4	—	—
5514		ON	NONE	OFF
		2B-1 5B-4	—	—
5515		ON	NONE	OFF
		2B-1-9 5B-4	—	—
5516		ON	NONE	OFF
		2B-1-10 5B-4	—	—
5517		ON	NONE	OFF
		2B-1-9-10 5B-4	—	—
5518		ON	NONE	OFF
		2B-1 5B-4	—	—

Single-Pole

Circuit No.	Schematic (Shown in UP Position)	Circuit with Rocker In ...			Circuit No.	Schematic (Shown in UP Position)	Circuit with Rocker In ...		
		DOWN Position	CENTER Position	UP Position			DOWN Position	CENTER Position	UP Position
5002		MOM. ON	NONE	OFF	5003		ON	ON	OFF
		2B-1	—	—			2A-1	2A-2B	2B-3
5521		MOM. ON	NONE	OFF	5541		ON	ON	OFF
		2B-1-9	—	—			2A-1	2A-2B	2B-3-9
5522		MOM. ON	NONE	OFF	5542		ON	ON	OFF
		2B-1-10	—	—			2A-1	2A-2B	2B-3-10
5523		MOM. ON	NONE	OFF	5543		ON	ON	OFF
		2B-1	—	—			2A-1	2A-2B	2B-3
5524		MOM. ON	NONE	OFF	5544		ON	ON	OFF
		2B-1	—	—			2A-1	2A-2B	2B-3
5525		MOM. ON	NONE	OFF	5545		ON	ON	OFF
		2B-1-9	—	—			2A-1	2A-2B	2B-3-9
5526		MOM. ON	NONE	OFF	5546		ON	ON	OFF
		2B-1-10	—	—			2A-1	2A-2B	2B-3-10
5528		MOM. ON	NONE	OFF	5547		ON	ON	OFF
		2B-1	—	—			2A-1-10	2A-2B	2B-3-9
					5548		ON	ON	OFF
							2A-1	2A-2B	2B-3

#### Two-Pole

4

Circuit No.	Schematic (Shown in UP Position)	Circuit with Rocker In ...		
		DOWN Position	CENTER Position	UP Position
3001		ON	ON	ON
		5B-4-2B-1	5B-4-2B-3	2B-3 5B-6
3501		ON	ON	ON
		5B-4-2B-1	5B-4-2B-3-9	2B-3-9 5B-6
3502		ON	ON	ON
		5B-4-2B-1	5B-4-2B-3-10	2B-3-10 5B-6
3503		ON	ON	ON
		5B-4-2B-1	5B-4-2B-3	2B-3 5B-6
3504		ON	ON	ON
		5B-4-2B-1	5B-4-2B-3	2B-3 5B-6
3505		ON	ON	ON
		5B-4-2B-1	5B-4-2B-3	2B-3 5B-6
3506		ON	ON	ON
		5B-4-2B-1	5B-4-2B-3	2B-3 5B-6
3507		ON	ON	ON
		5B-4-2B-1	5B-4-2B-3-9	2B-3-9 5B-6
3508		ON	ON	ON
		5B-4-2B-1	5B-4-2B-3	2B-3 5B-6

Circuit No.	Schematic (Shown in UP Position)	Circuit with Rocker In ...		
		DOWN Position	CENTER Position	UP Position
3002		OFF	1-ON	2-ON
		2B-1 5B-4	2B-3 5B-4	2B-3 5B-6
3521		OFF	1-ON	2-ON
		2B-1 5B-4	2B-3-9 5B-4	2B-3-9 5B-6
3522		OFF	1-ON	2-ON
		2B-1 5B-4	2B-3-10 5B-4	2B-3-10 5B-6
3523		OFF	1-ON	2-ON
		2B-1 5B-4	2B-3 5B-4	2B-3 5B-6
3524		OFF	1-ON	2-ON
		2B-1 5B-4	2B-3 5B-4	2B-3 5B-6
3525		OFF	1-ON	2-ON
		2B-1 5B-4	2B-3-9 5B-4	2B-3-9 5B-6
3526		OFF	1-ON	2-ON
		2B-1 5B-4	2B-3-10 5B-4	2B-3-10 5B-6
3527		OFF	1-ON	2-ON
		2B-1-10 5B-4	2B-3-9 5B-4	2B-3-9 5B-6
3528		OFF	1-ON	2-ON
		2B-1 5B-4	2B-3 5B-4	2B-3 5B-6

Two-Pole

Circuit No.	Schematic (Shown in UP Position)	Circuit with Rocker In ...		
		DOWN Position	CENTER Position	UP Position
3005		MOM. ON	ON	MOM. ON
		2B-1 5B-4	2B-1 5B-6	2B-3 5B-6
3581		MOM. ON	ON	MOM. ON
		2B-1 5B-4	2B-1 5B-6	2B-3-9 5B-6
3582		MOM. ON	ON	MOM. ON
		2B-1 5B-4	2B-1 5B-6	2B-3-10 5B-6
3583		MOM. ON	ON	MOM. ON
		2B-1 5B-4	2B-1 5B-6	2B-3 5B-6
3584		MOM. ON	ON	MOM. ON
		2B-1 5B-4	2B-1 5B-6	2B-3 5B-6
3585		MOM. ON	ON	MOM. ON
		2B-1 5B-4	2B-1 5B-6	2B-3-9 5B-6
3586		MOM. ON	ON	MOM. ON
		2B-1 5B-4	2B-1 5B-6	2B-3-10 5B-6
3587		MOM. ON	ON	MOM. ON
		2B-1-10 5B-4	2B-1-10 5B-6	2B-3-9 5B-6
3588		MOM. ON	ON	MOM. ON
		2B-1 5B-4	2B-1 5B-6	2B-3 5B-6

Circuit No.	Schematic (Shown in UP Position)	Circuit with Rocker In ...		
		DOWN Position	CENTER Position	UP Position
4001		NONE	ON	MOM. ON
		2B-1 5B-4	2B-1 5B-4	2B-3 5B-6
4501		NONE	ON	MOM. ON
		2B-1 5B-4	2B-1 5B-4	2B-3-9 5B-6
4502		NONE	ON	MOM. ON
		2B-1 5B-4	2B-1 5B-4	2B-3-10 5B-6
4503		NONE	ON	MOM. ON
		2B-1 5B-4	2B-1 5B-4	2B-3 5B-6
4504		NONE	ON	MOM. ON
		2B-1 5B-4	2B-1 5B-4	2B-3 5B-6
4505		NONE	ON	MOM. ON
		2B-1 5B-4	2B-1 5B-4	2B-3-9 5B-6
4506		NONE	ON	MOM. ON
		2B-1 5B-4	2B-1 5B-4	2B-3-10 5B-6
4507		NONE	ON	MOM. ON
		2B-1-10 5B-4	2B-1-10 5B-4	2B-3-9 5B-6
4508		NONE	ON	MOM. ON
		2B-1 5B-4	2B-1 5B-4	2B-3 5B-6

### Two-Pole

4

Circuit No.	Schematic (Shown in UP Position)	Circuit with Rocker In ...		
		DOWN Position	CENTER Position	UP Position
5004		ON	ON	OFF
		2A-1 5A-4	2A-2B 5A-5B	2B-3 5B-6
5561		ON	ON	OFF
		2A-1 5A-4	2A-2B 5A-5B	2B-3-9 5B-6
5562		ON	ON	OFF
		2A-1 5A-4	2A-2B 5A-5B	2B-3-10 5B-6
5563		ON	ON	OFF
		2A-1 5A-4	2A-2B 5A-5B	2B-3 5B-6
5564		ON	ON	OFF
		2A-1 5A-4	2A-2B 5A-5B	2B-3 5B-6
5565		ON	ON	OFF
		2A-1 5A-4	2A-2B 5A-5B	2B-3-9 5B-6
5566		ON	ON	OFF
		2A-1 5A-4	2A-2B 5A-5B	2B-3-10 5B-6
5567		ON	ON	OFF
		2A-1-10 5A-4	2A-2B 5A-5B	2B-3-9 5B-6
5568		ON	ON	OFF
		2A-1 5A-4	2A-2B 5A-5B	2B-3 5B-6

Circuit No.	Schematic (Shown in UP Position)	Circuit with Rocker In ...		
		DOWN Position	CENTER Position	UP Position
5005		2-ON	1-ON	OFF
		2B-1 5B-4	2B-3 5B-4	2B-3 5B-6
5581		2-ON	1-ON	OFF
		2B-1 5B-4	2B-3-9 5B-4	2B-3-9 5B-6
5582		2-ON	1-ON	OFF
		2B-1 5B-4	2B-3-10 5B-4	2B-3-10 5B-6
5583		2-ON	1-ON	OFF
		2B-1 5B-4	2B-3 5B-4	2B-3 5B-6
5584		2-ON	1-ON	OFF
		2B-1 5B-4	2B-3 5B-4	2B-3 5B-6
5585		2-ON	1-ON	OFF
		2B-1 5B-4	2B-3-9 5B-4	2B-3-9 5B-6
5586		2-ON	1-ON	OFF
		2B-1 5B-4	2B-3-10 5B-4	2B-3-10 5B-6
5587		2-ON	1-ON	OFF
		2B-1-10 5B-4	2B-3-9 5B-4	2B-3-9 5B-6
5588		2-ON	1-ON	OFF
		2B-1 5B-4	2B-3 5B-4	2B-3-9 5B-6
6001		ON	NONE	ON
		2A-2B-5A-5B- 10-1-4-3	—	3-6-1

**Dimensions**

Approximate Dimensions in Inches (mm)

**Switch Base with Rocker Button**

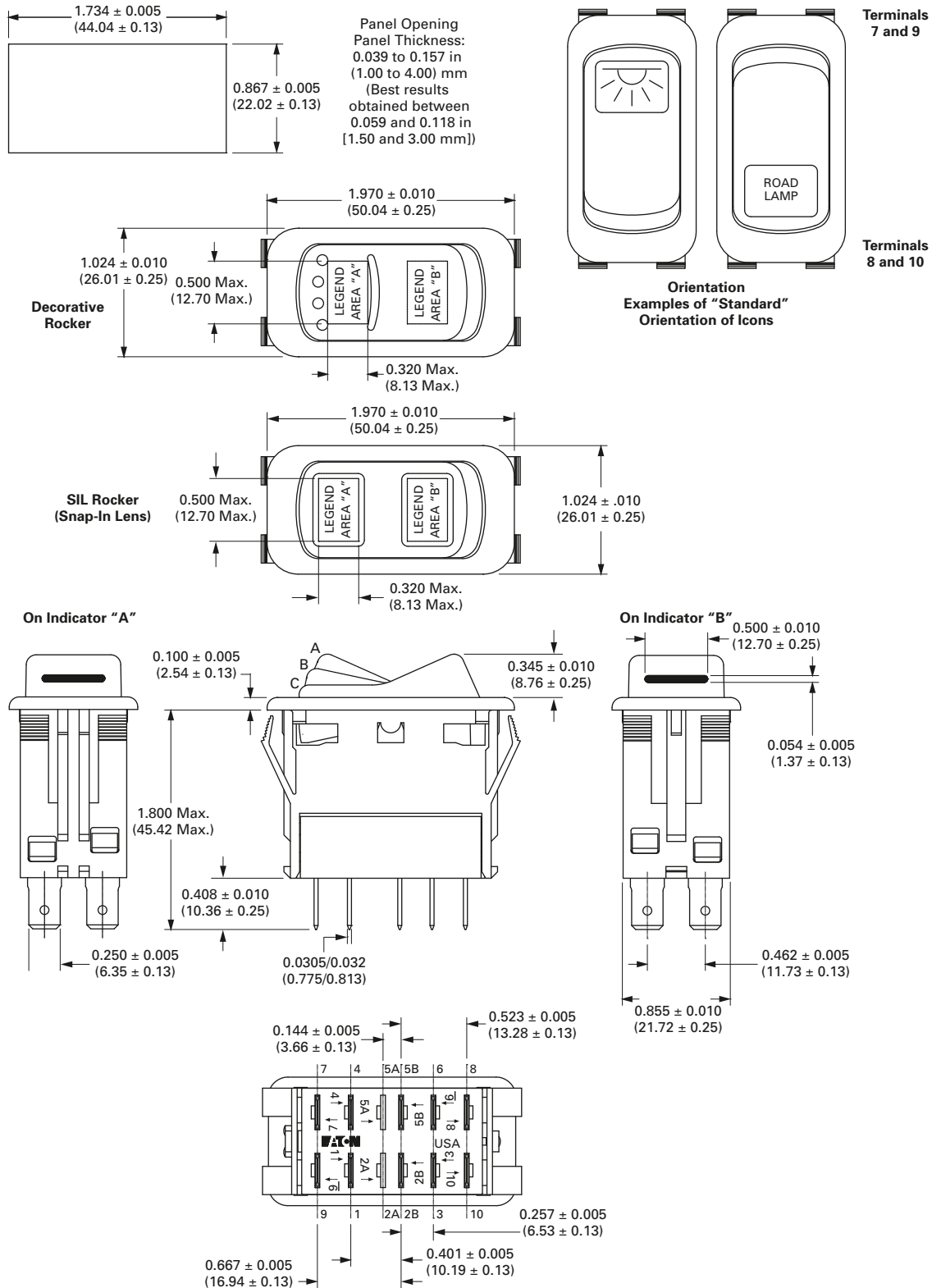

# 4.2

## Rockers

NGR—New Generation Rockers

Approximate Dimensions in Inches (mm)

4

### Locking Rocker

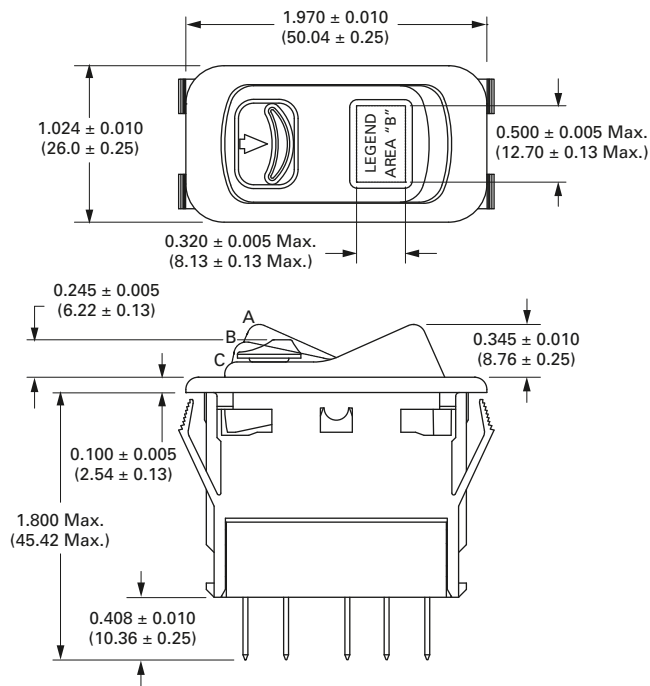

### Sealed Rocker

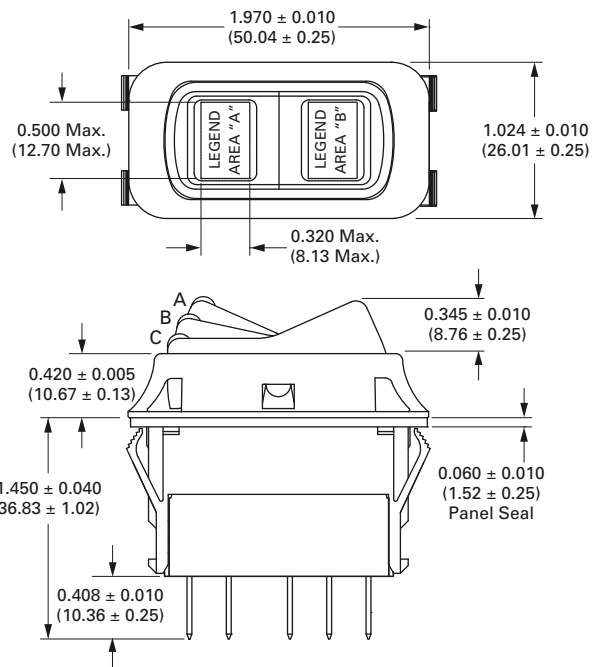

### Indicator

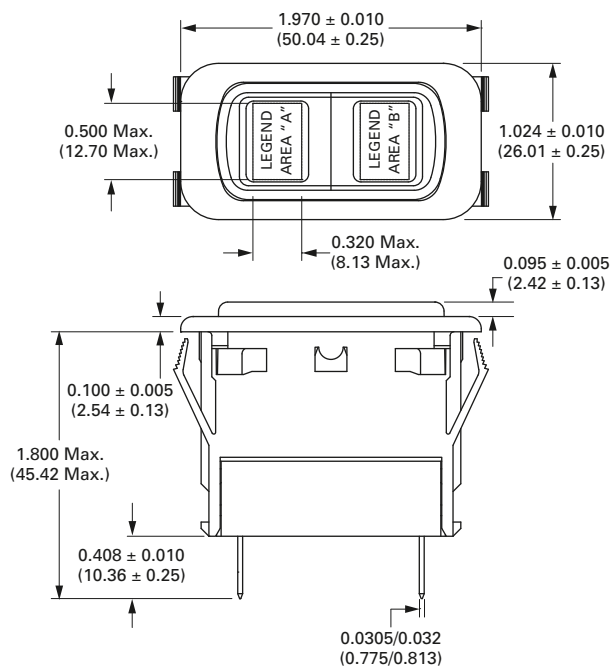

### Label Rocker

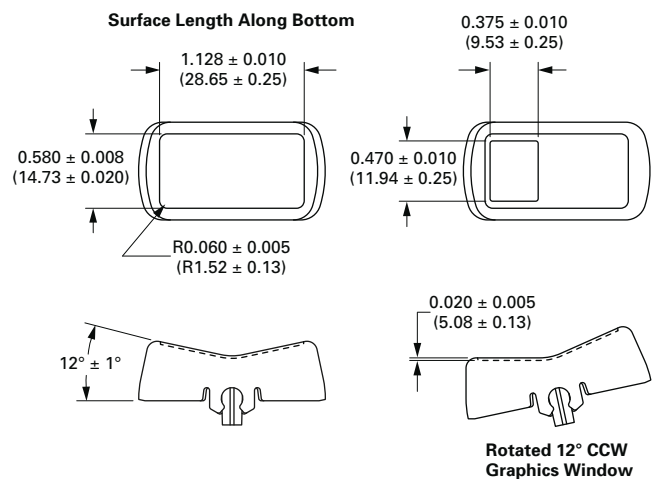

Note: Graphics window may be on both ends or either end of part. Dimensions shown are typical.