



## SRS HEADPHONE 3D SURROUND PROCESSOR

### GENERAL DESCRIPTION

The **NJM2190** is a headphone surround processor based on SRS technology. It provides a realistic and spacious listening experience through standard headphones.

The features of low operating voltage, low output noise, low operating current are very suitable for portable audio applications.

### PACKAGE OUTLINE

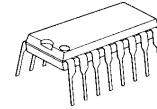

**NJM2190D**

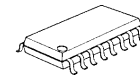

**NJM2190M**

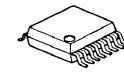

**NJM2190V**

### FEATURES

- Operating Voltage (1.8 to 6.0V)
- Low Operating Current (1.3mA typ. at SRS mode)
- Low Output Noise (12.0μVrms typ. at SRS mode)
- WIDTH Control
- Bipolar Technology
- Package Outline DIP16, DMP16, SSOP16

### PIN CONFIGURATION

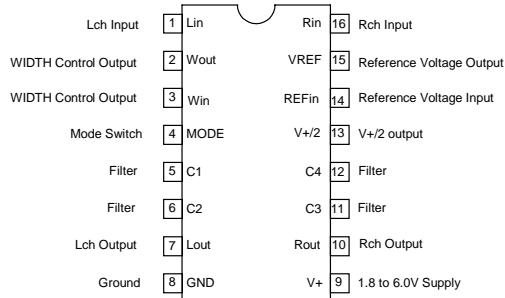

### BLOCK DIAGRAM

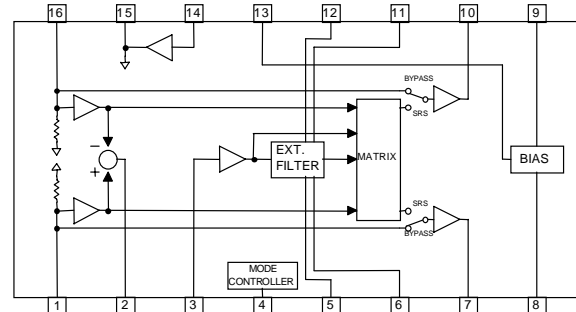

The SRS HEADPHONE technology right incorporated in the NJM2190 are owned by SRS Labs, a U.S. Corporation and licensed to New Japan Radio Co., Ltd. SRS HEADPHONE is protected under U.S. and foreign patents issued and/or pending. SRS HEADPHONE and the are trademarks of SRS Labs, Inc. in the United States and selected foreign countries. Neither the purchase of the NJM2190, nor the corresponding sale of audio enhancement equipment conveys the right to sell commercialized recordings made with any SRS technology.

SRS Labs requires that all users of the NJM2190 must enter into a license agreement directly with SRS Labs if the royalty is not included in the purchase price. SRS Labs also requires any users to comply with all rules and regulations as outlined in the SRS Trademark Usage Manual.

For further information, please contact:

SRS Labs, Inc.

2909 Daimler Street. Santa Ana, CA 92705 USA

Tel: 949-442-1070 Fax: 949-852-1099 <http://www.srslabs.com>

# NJM2190

## ■ABSOLUTE MAXIMUM RATING (Ta=25°C)

PARAMETER	SYMBOL	RATINGS	UNIT
Supply Voltage	V+	7	V
Power Dissipation	P <sub>D</sub>	(DIP16) 500 (DMP16) 300 (SSOP16) 300	mW
Operating Temperature Range	T <sub>opr</sub>	-20 to +75	°C
Storage Temperature Range	T <sub>stg</sub>	-40 to +125	°C

## ■ELECTRICAL CHARACTERISTICS (V+=3V, V<sub>IN</sub>=-26dBV(50mVrms), Ta=25°C, unless otherwise specified.)

PARAMETER	SYMBOL	CONDITION	CONDITION					MIN	TYP	MAX	UNIT
			INPUT		OUTPUT	MODE	WIDTH VR(*1)				
			L	R							
Operating Voltage	V+		-	-	-	-	-	1.8	3.0	6.0	V
Operating Current	I <sub>cc</sub>	No Signal	0	0	-	BYPASS	-	-	0.7	1.0	mA
			0	0	-	SRS	MIN	-	1.3	1.8	
			0	0	-	SRS	MAX	-	1.3	1.8	
Reference Voltage	V <sub>REF</sub>	V <sup>+</sup> /2	-	-	-	-	-	1.3	1.5	1.7	V
Maximum Input Voltage	V <sub>IM</sub>	f=1kHz THD=1%	V <sub>IN</sub>	0	L	BYPASS	-	-	0.1 (1012)	-	dBV (mVrms)
			0	V <sub>IN</sub>	R						
		f=100Hz THD=1%	V <sub>IN</sub>	0	L	SRS	MIN	-	-11.8 (257)	-	
			0	V <sub>IN</sub>	R						
		f=100Hz THD=1%	V <sub>IN</sub>	0	L	SRS	MAX	-	-15.8 (162)	-	
			0	V <sub>IN</sub>	R						
		V+=1.8V f=1kHz THD=1%	V <sub>IN</sub>	0	L	BYPASS	-	-6.7 (462)	-4.7 (582)	-	
			0	V <sub>IN</sub>	R						
		V+=1.8V f=100Hz THD=1%	V <sub>IN</sub>	0	L	SRS	MIN	-	-16.7 (146)	-	
			0	V <sub>IN</sub>	R						
		V+=1.8V f=100Hz THD=1%	V <sub>IN</sub>	0	L	SRS	MAX	-22.5 (75)	-20.5 (94)	-	
			0	V <sub>IN</sub>	R						

**■ ELECTRICAL CHARACTERISTICS** ( $V^+=3V, V_{IN}=-26dBV(50mV_{rms}), T_a=25^\circ C$ , unless otherwise specified.)

PARAMETER	SYMBOL		CONDITION					MIN	TYP	MAX	UNIT
			INPUT		OUTPUT	MODE	WIDTH VR <sup>(*)</sup>				
			L	R							
Maximum Input Voltage <sup>(*)</sup>	V <sub>IN</sub>	V <sup>+</sup> =1.8V f=1kHz THD=1%	V <sub>IN</sub>	V <sub>IN</sub>	L	SRS	MIN	-	-16.7 (146)	-	dBV (mVrms)
					R						
		V <sup>+</sup> =1.8V f=1kHz THD=1%	V <sub>IN</sub>	V <sub>IN</sub>	L	SRS	MAX	-	-16.7 (146)	-	
					R						
V <sup>+</sup> =1.8V f=100Hz THD=1%	V <sub>IN</sub>	-V <sub>IN</sub>	L	SRS	MIN	-	-22.9 (72)	-			
			R								
V <sup>+</sup> =1.8V f=100Hz THD=1%	V <sub>IN</sub>	-V <sub>IN</sub>	L	SRS	MAX	-28.5 (38)	-26.5 (47)	-			
			R								
Output Noise	V <sub>NO</sub>	R <sub>g</sub> =0Ω A-Weighted	0	0	L	BYPASS	-	-	-110 (3.0)	-104 (6.0)	dBV (μVrms)
					R						
			0	0	L	SRS	MIN	-	-98 (12.0)	-	
					R						
			0	0	L	SRS	MAX	-	-98 (12.0)	-92 (24.0)	
					R						
Total Harmonic Distortion	THD	V <sup>+</sup> =1.8V f=1kHz	V <sub>IN</sub>	0	L	BYPASS	-	-	0.02	-	%
					R						
			V <sub>IN</sub>	0	L	SRS	MIN	-	0.10	-	
					R						
			V <sub>IN</sub>	0	L	SRS	MAX	-	0.25	0.5	
					R						
0	V <sub>IN</sub>	L	SRS	MAX	-	0.25	0.5				
		R									
BYPASS Gain	G <sub>BYP</sub>	f=1kHz	V <sub>IN</sub>	0	L	BYPASS	-	-1.0	0.0	1.0	dB
			0	V <sub>IN</sub>	R						
L+R Gain	G <sub>L+R</sub>	f=1kHz	V <sub>IN</sub>	V <sub>IN</sub>	L	SRS	MIN	-	0.0	-	dB
					R						
			V <sub>IN</sub>	V <sub>IN</sub>	L	SRS	MAX	-1.0	0.0	1.0	
					R						

# NJM2190

## ■ELECTRICAL CHARACTERISTICS ( $V_+=3V, V_{IN}=-26dBV(50mV_{rms}), T_a=25^\circ C$ , unless otherwise specified.)

PARAMETER	SYMBOL		CONDITION					MIN	TYP	MAX	UNIT
			INPUT		OUTPUT	MODE	WIDTH VR <sup>(*)</sup>				
			L	R							
L-R Gain <sup>(*)</sup>	GL-R	f=100Hz	V <sub>IN</sub>	-V <sub>IN</sub>	L	SRS	MIN	3.7	5.7	7.7	dB
					R						
			V <sub>IN</sub>	-V <sub>IN</sub>	L	SRS	MAX	19.3	21.3	23.3	
					R						
Channel Separation	CS	f=1kHz	0	V <sub>IN</sub>	L	BYPASS	-	60.0	80.0	-	dB
			V <sub>IN</sub>	0	R						
MODE Select Control Voltage	V <sub>IH</sub>	High Level	-	-	-	-	-	1.3	-	V+	V
	V <sub>IL</sub>	Low Level	-	-	-	-	-	0.0	-	0.5	

(\*1) Refer to application circuit 1.

(\*2) The word '-V<sub>IN</sub>' signifies opposite phase of 'V<sub>IN</sub>'.

### ■MODE Switch

	MODE
BYPASS MODE	L
SRS MODE	H

## ■ TERMINAL DESCRIPTION

PIN NO.	SYMBOL	FUNCTION	EQUIVALENT CIRCUIT	VOLTAGE
1 16	Lin Rin	Audio Input		$V+/2$
2	Wout	WIDTH Control Output		$V+/2$
3	Win	WIDTH Control Input		$V+/2$
4	MODE	Mode Switch		-

# NJM2190

## ■TERMINAL DESCRIPTION

PIN NO.	SYMBOL	FUNCTION	EQUIVALENT CIRCUIT	VOLTAGE
5	C1	Capacitor Terminal 1 for Filter		V+/2
6	C2	Capacitor Terminal 2 for Filter		V+/2
7 10	Lout Rout	Audio Output		V+/2
8	GND	Ground		0V

## ■ TERMINAL DESCRIPTION

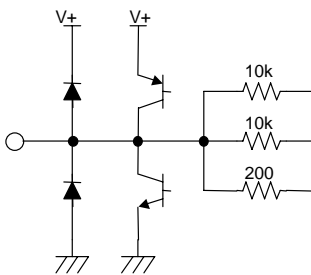
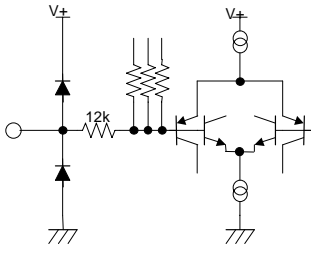
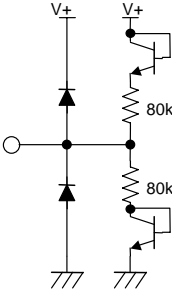
PIN NO.	SYMBOL	FUNCTION	EQUIVALENT CIRCUIT	VOLTAGE
9	V+	Power Supply		V+
11	C3	Capacitor Terminal 3 for Filter		V+/2
12	C4	Capacitor Terminal 4 for Filter		V+/2
13	V+/2	V+/2 Output		V+/2

# NJM2190

## ■ TERMINAL DESCRIPTION

PIN NO.	SYMBOL	FUNCTION	EQUIVALENT CIRCUIT	VOLTAGE
14	REFin	Reference Voltage Input		$V+/2$
15	VREF	Reference Voltage Output		$V+/2$



## APPLICATION CIRCUIT 1

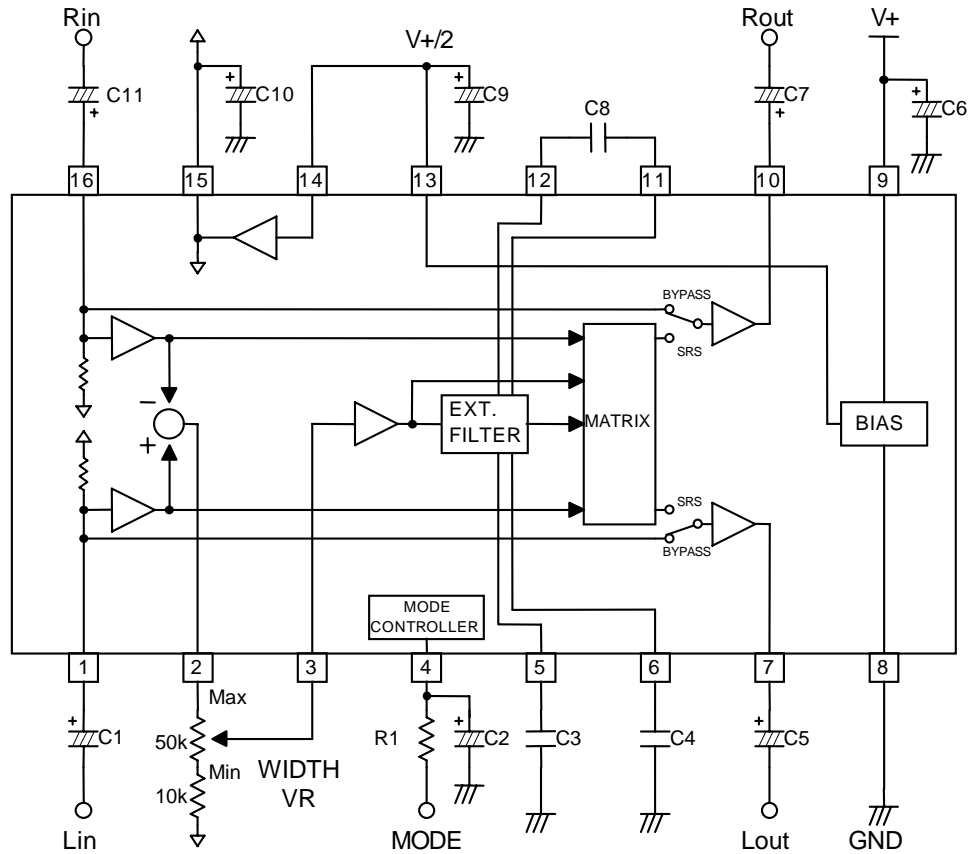

Parts No.	Value	Tolerance	Parts No.	Value	Tolerance
R1	22kΩ	5%	C6	22 to 100µF	-
C1	10µF	20%	C7	10µF	20%
C2	10µF	20%	C8	4.7nF	5%
C3	3.3nF	5%	C9	1 to 10µF	-
C4	0.1µF	5%	C10	10 to 7µF	-
C5	10µF	20%	C11	10µF	20%

# NJM2190

## APPLICATION CIRCUIT 2 (Without using internal V+/2.)

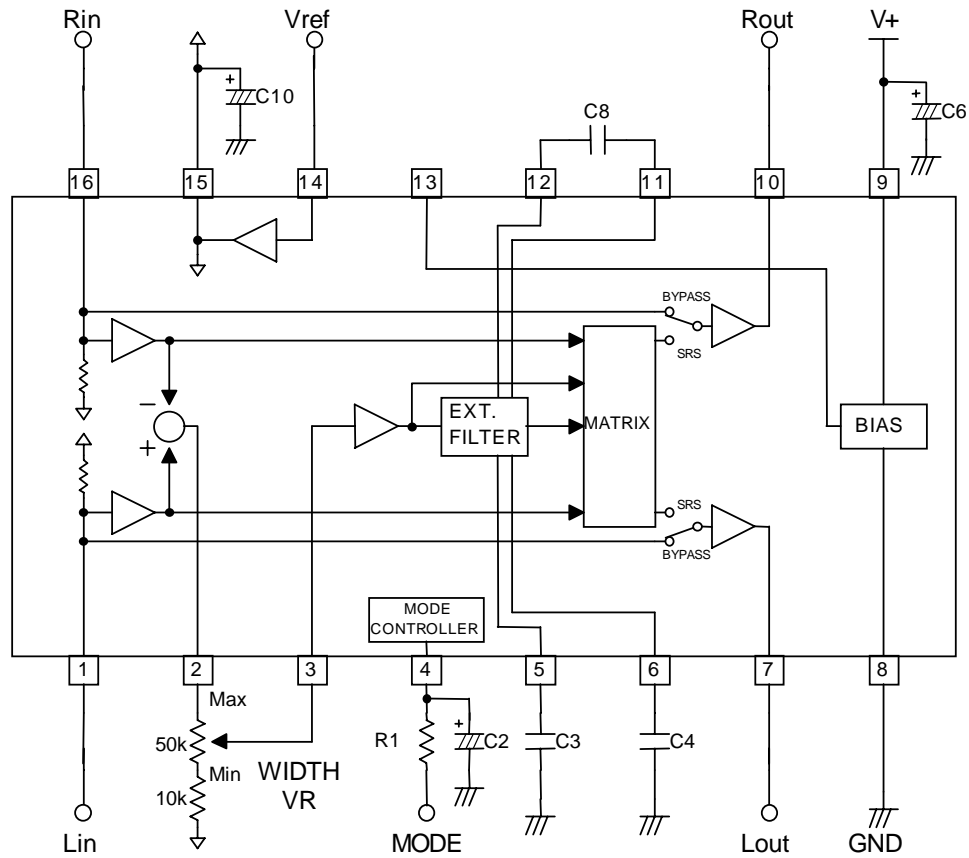

Parts No.	Value	Tolerance	Parts No.	Value	Tolerance
R1	22k $\Omega$	5%	C6	22 to 100 $\mu$ F	-
C2	10 $\mu$ F	20%	C8	4.7nF	5%
C3	3.3nF	5%	C10	10 to 47 $\mu$ F	-
C4	0.1 $\mu$ F	5%			

## ■ TYPICAL CHARACTERISTICS

### GAIN STRUCTURE(WIDTH VR:MAX)

Conditions : SRS MODE , WIDTH VR=MAX , V+=3V

a:Vin=-26dBV (Lch.) Vout=Lch.    b:Vin=-26dBV (Rch.) Vout=Lch.

c:Vin=-26dBV (L+Rch.) Vout=Lch.    d:Vin=-26dBV (L-Rch.) Vout=Lch.

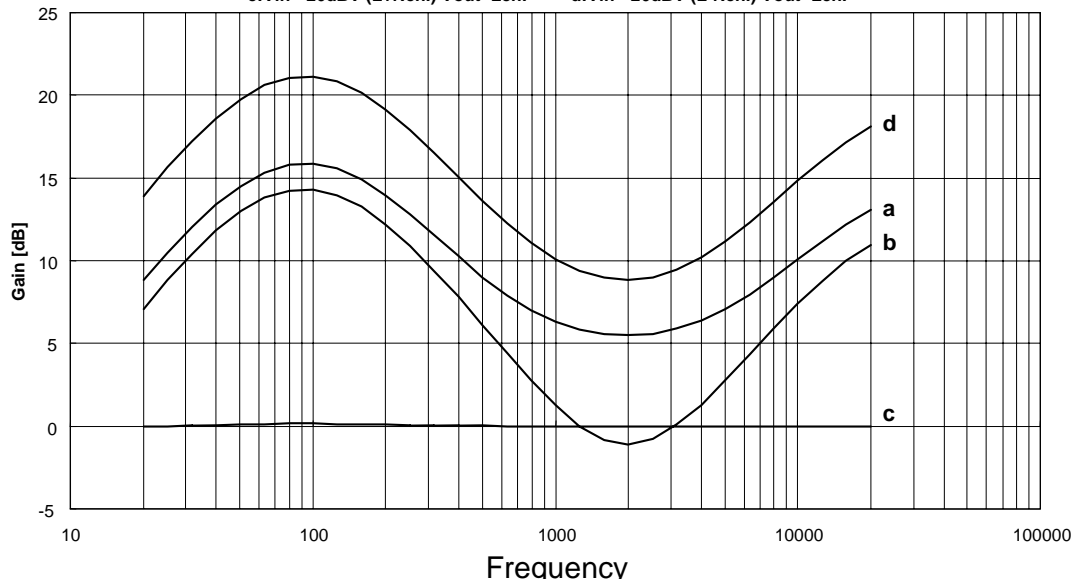

### GAIN STRUCTURE(WIDTH VR:MIN)

Conditions : SRS MODE , WIDTH VR=MIN , V+=3V

a:Vin=-26dBV(Lch.) Vout=Lch.    b:Vin=-26dBV(Rch.) Vout=Lch.

c:Vin=-26dBV(L+Rch.) Vout=Lch.    d:Vin=-26dBV(L-Rch.) Vout=Lch.

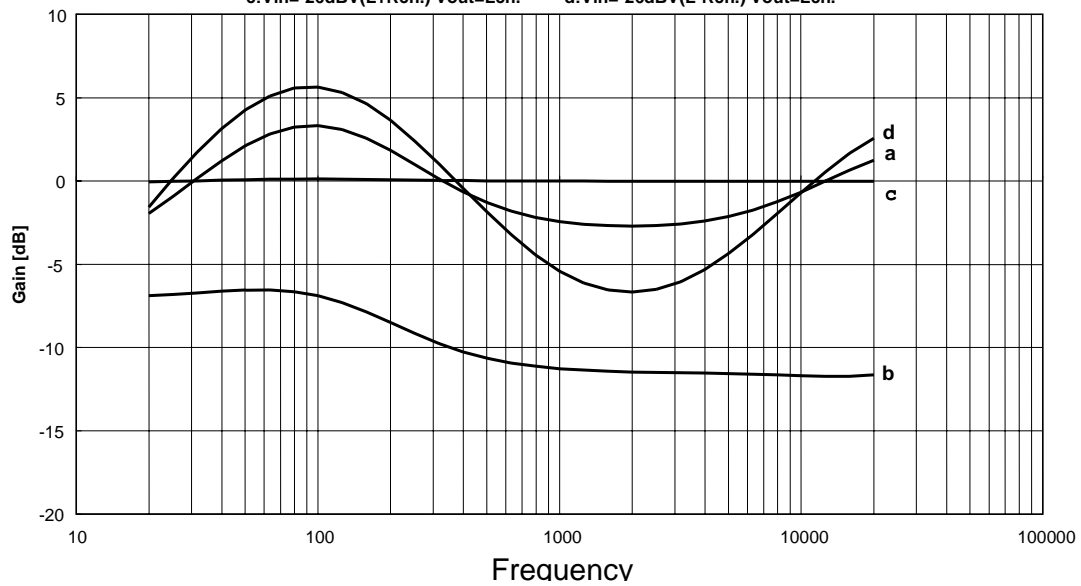

## ■ TYPICAL CHARACTERISTICS

### Maximum Input Voltage vs. Supply Voltage

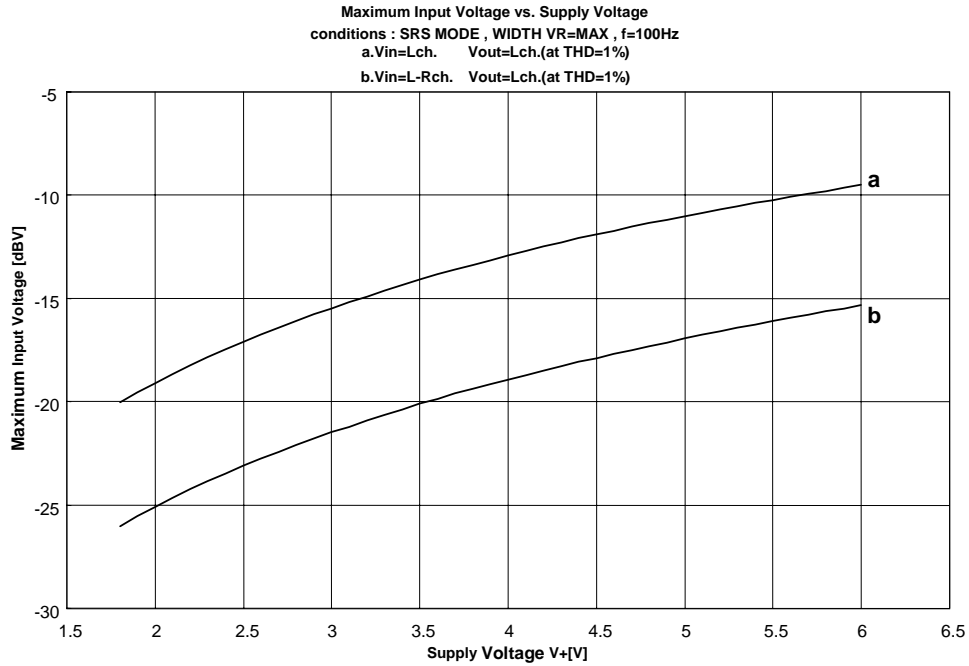

### Maximum Input Voltage vs. WIDTH VR

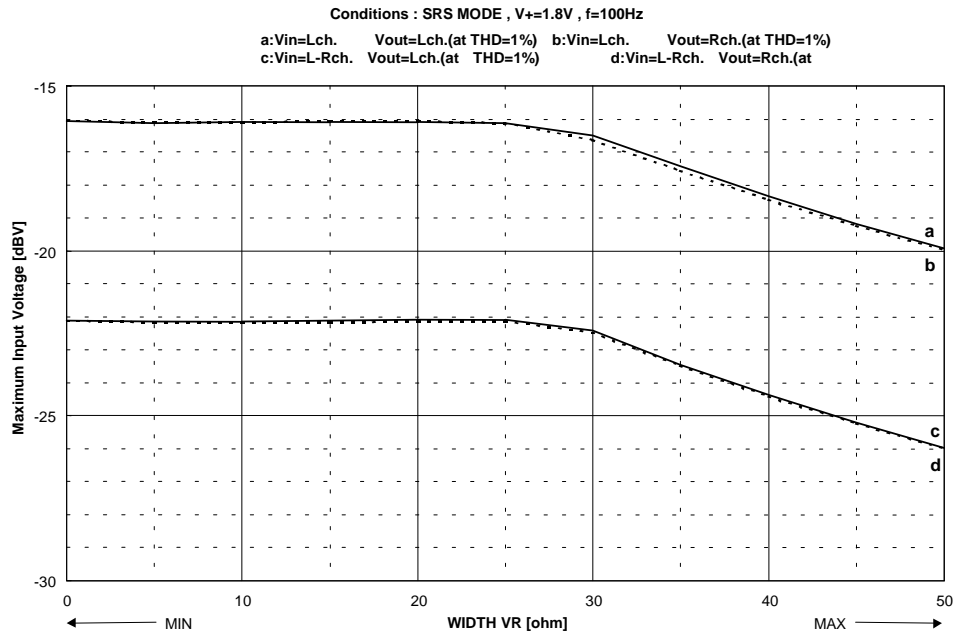

**[CAUTION]**  
 The specifications on this databook are only given for information , without any guarantee as regards either mistakes or omissions. The application circuits in this databook are described only to show representative usages of the product and not intended for the guarantee or permission of any right including the industrial rights.