

SMA type connector

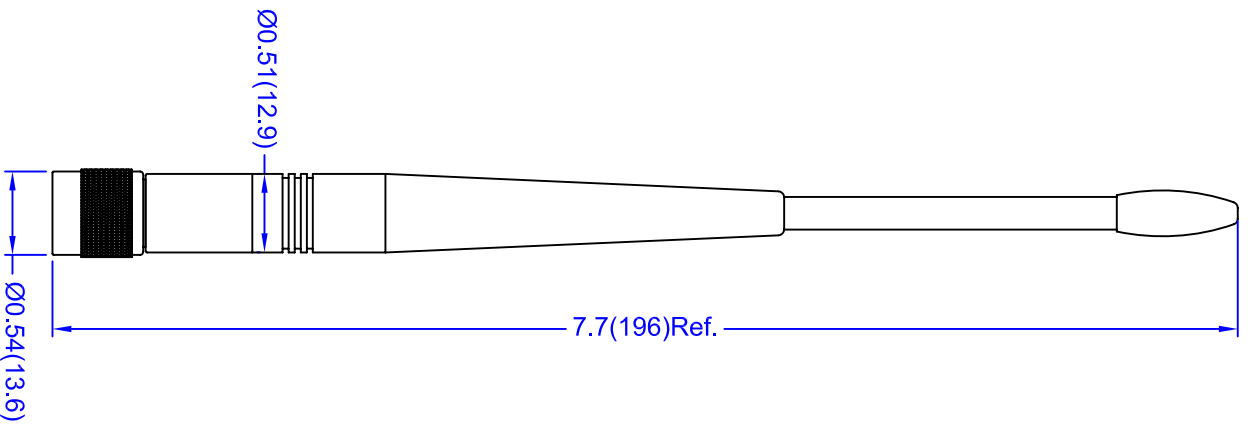

TNC type connector

**Electrical Properties:**

Frequency Range: 902-928 MHz  
 Impedance: 50Ω nominal  
 VSWR: <2.0:1  
 Gain: 2.0 dBi  
 Radiation: Omni  
 Polarization: Vertical  
 Wave: Half Wave Dipole

**Mechanical Properties:**

Material: Polyurethane(Black)  
 Whip: Brass with  
 Connector: black chrome plating  
 Operation Temp.: -20°C to +65°C  
 Storage Temp.: -30°C to +75°C

This is a RoHS compliant product.

TITLE	900 MHz ISM Band Straight Antenna - 467 model		Rev. Date	SHEET
UNIT	DWG. NO.	S467XX - 915	02/09/06	1 of 2
SCALE	none			
<b>NEARSON</b>				

## Series Part Numbers

Connector Code -XX-	Description	P / N
AM	SMA Plug	S467AM-915
AH	SMA Plug Reverse Polarity	S467AH-915
TC	TNC Plug	S467TC-915
TR	TNC Plug Reverse Polarity	S467TR-915

## Connector Interface

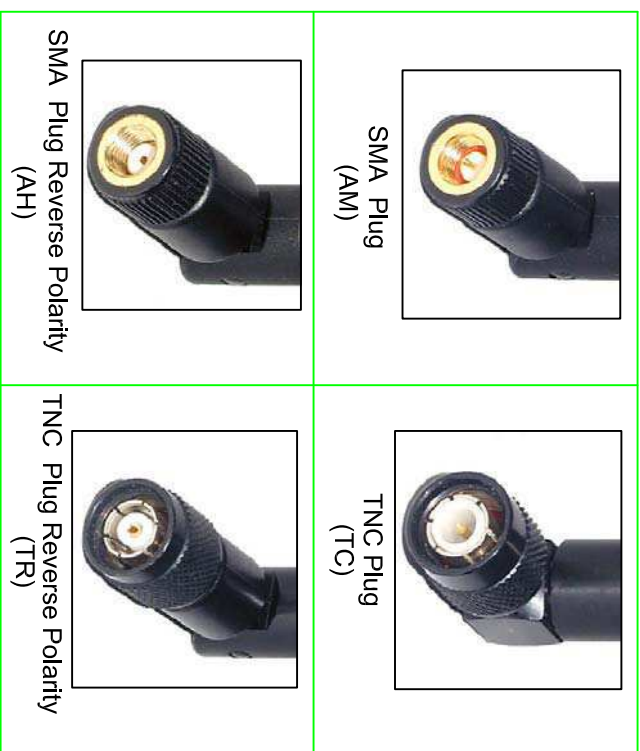

TITLE	900 MHz ISM Band Straight Antenna - 467 model	Rev. Date	SHEET
UNIT	DWG. NO.	02/09/06	2 of 2
In.(mm)	S467XX - 915		
SCALE			
none			

**NEARSON**