

### FEATURES

- **HIGH GAIN BANDWIDTH PRODUCT:**  $f_r = 10 \text{ GHz}$
- **LOW NOISE FIGURE:**
  - 1.7 dB at 2 GHz
  - 2.6 dB at 4 GHz
- **HIGH ASSOCIATED GAIN:**
  - 12.5 dB at 2 GHz
  - 8.0 dB at 4 GHz
- **EXCELLENT LOW VOLTAGE LOW CURRENT PERFORMANCE**

### DESCRIPTION

NEC's NE680 series of NPN epitaxial silicon transistors is designed for low noise, high gain and low cost applications. Both the chip and micro-x versions are suitable for applications up to 6 GHz. The NE680 die is also available in six different low cost plastic surface mount package styles. The NE680's high  $f_r$  makes it ideal for low voltage/low current applications, down to as low as 0.5 V / 0.5 mA. IC max for the NE680 series is 35 mA. For higher current applications see the NE681 se-

 00 (CHIP)	 35 (MICRO-X)
 18 (SOT 343 STYLE)	 19 (3 PIN ULTRA SUPER MINI MOLD)
 30 (SOT 323)	 33 (SOT 23 STYLE)
 39 (SOT 143 STYLE)	 39R (SOT 143R STYLE)

NE68018  
NOISE FIGURE & ASSOCIATED GAIN  
vs. FREQUENCY

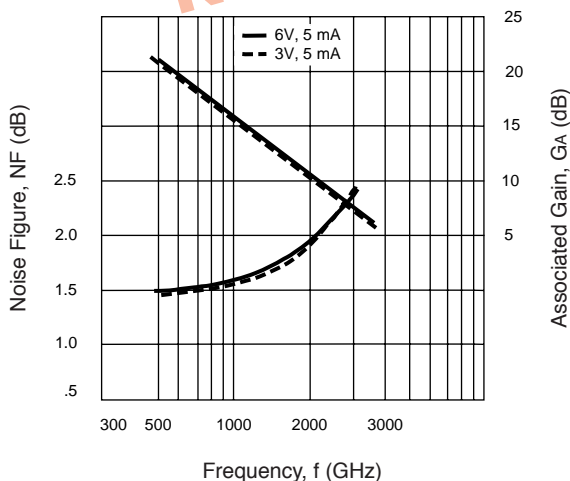

# NE680 SERIES

## ELECTRICAL CHARACTERISTICS (T<sub>A</sub> = 25°C)

PART NUMBER EIAJ <sup>1</sup> REGISTERED NUMBER PACKAGE OUTLINE			NE68000 00 (CHIP)			NE68018 2SC5013 18			NE68019 2SC5008 19		
SYMBOLS	PARAMETERS AND CONDITIONS	UNITS	MIN	TYP	MAX	MIN	TYP	MAX	MIN	TYP	MAX
f <sub>T</sub>	Gain Bandwidth Product at V <sub>CE</sub> = 6 V, I <sub>C</sub> = 10 mA	GHz		10			10			10	
NF	Noise Figure at V <sub>CE</sub> = 6 V, I <sub>C</sub> = 5 mA, f = 1 GHz f = 2 GHz f = 4 GHz	dB dB dB		1.7 2.4 2.6			1.6 1.8 3			1.7 1.9	
GNF	Associated Gain at V <sub>CE</sub> = 6 V, I <sub>C</sub> = 5 mA, f = 1 GHz f = 2 GHz f = 4 GHz	dB dB dB		12.5 8			14 10.2			13.5 9.6	
MAG	Maximum Available Gain at V <sub>CE</sub> = 6 V, I <sub>C</sub> = 10 mA f = 1 GHz f = 2 GHz f = 4 GHz	dB dB dB		18.5 16.2 10.2			19 12.7 8.2			18.5 11.8 7.3	
IS <sub>21</sub> EI <sup>2</sup>	Insertion Power Gain at V <sub>CE</sub> = 6 V, I <sub>C</sub> = 10 mA, f = 1 GHz f = 2 GHz f = 4 GHz	dB dB dB	10.5	17 12.5 7.5		7.5	15.5 9.8 4.6			15 9.2 4.4	
h <sub>FE</sub>	Forward Current Gain <sup>2</sup> at V <sub>CE</sub> = 6 V, I <sub>C</sub> = 10 mA V <sub>CE</sub> = 3 V, I <sub>C</sub> = 5 mA		50	100	250	50	100	250	80		160
I <sub>CBO</sub>	Collector Cutoff Current at V <sub>CB</sub> = 10 V, I <sub>E</sub> = 0 mA	μA			1.0			1.0			1.0
I <sub>EBO</sub>	Emitter Cutoff Current at V <sub>EB</sub> = 1V, I <sub>C</sub> = 0 mA	μA			1.0			1.0			1.0
CRE <sup>3</sup>	Feedback Capacitance at V <sub>CB</sub> = 1 V, I <sub>E</sub> = 0 mA, f = 1 MHz	pF					0.3	0.7		0.3	0.7
P <sub>T</sub>	Total Power Dissipation	mW			400			150			100
R <sub>TH</sub> (J-A)	Thermal Resistance (Junction to Ambient)	°C/W						833			1000
R <sub>TH</sub> (J-C)	Thermal Resistance (Junction to Case)	°C/W			120			200			200

## ELECTRICAL CHARACTERISTICS (T<sub>A</sub> = 25°C)

PART NUMBER EIAJ <sup>1</sup> REGISTERED NUMBER PACKAGE OUTLINE			NE68030 2SC4228 30			NE68033 2SC3585 33			NE68035 2SC3587 35			NE68039/39R 2SC4095 39			
SYMBOLS	PARAMETERS AND CONDITIONS	UNITS	MIN	TYP	MAX	MIN	TYP	MAX	MIN	TYP	MAX	MIN	TYP	MAX	
f <sub>T</sub>	Gain Bandwidth Product at V <sub>CE</sub> = 6 V, I <sub>C</sub> = 10 mA	GHz		10			10			10			10		
NF	Noise Figure at V <sub>CE</sub> = 6 V, I <sub>C</sub> = 5 mA, f = 1 GHz f = 2 GHz f = 4 GHz	dB dB dB		1.5 1.7 2.9			1.6 1.8 2.1	3.0		1.7 2.6	2.4		1.7 2.6	2.5	
GNF	Associated Gain at V <sub>CE</sub> = 6 V, I <sub>C</sub> = 5 mA, f = 1 GHz f = 2 GHz f = 4 GHz	dB dB dB		12.5 9.4 5.3			11.0 9.0 4.2			12.5 8			11 6.5		
MAG	Maximum Available Gain at V <sub>CE</sub> = 6 V, I <sub>C</sub> = 10 mA f = 1 GHz f = 2 GHz f = 4 GHz	dB dB dB		17 10.9 6.8			17 10.9 6.7			18.5 16.2 10.2			18 12.4 8.7		
IS <sub>21</sub> EI <sup>2</sup>	Insertion Power Gain at V <sub>CE</sub> = 6 V, I <sub>C</sub> = 10 mA, f = 1 GHz f = 2 GHz f = 2 GHz	dB dB dB		13.5 8.5 3.6			13 6.7 3.7		10.5	17 12.5 7.5			14.5 9.6 4.9		
h <sub>FE</sub>	Forward Current Gain <sup>2</sup> at V <sub>CE</sub> = 6 V, I <sub>C</sub> = 10 mA V <sub>CE</sub> = 3 V, I <sub>C</sub> = 5 mA		50	100	250	50	100	250	50	100	250	50	100	250	
I <sub>CBO</sub>	Collector Cutoff Current at V <sub>CB</sub> = 10 V, I <sub>E</sub> = 0 mA	μA			1.0			1.0			1.0			1.0	
I <sub>EBO</sub>	Emitter Cutoff Current at V <sub>EB</sub> = 1V, I <sub>C</sub> = 0 mA	μA			1.0			1.0			1.0			1.0	
Cre <sup>3</sup>	Feedback Capacitance at V <sub>CB</sub> = 3V, I <sub>E</sub> = 0 mA, f = 1 MHz V <sub>CE</sub> = 10 V, I <sub>E</sub> = 0 mA, f = 1 MHz	pF pF		0.3	0.7			0.3	0.8		0.2	0.7		0.25	0.8
P <sub>T</sub>	Total Power Dissipation	mW			150			200			290			200	
R <sub>TH</sub> (J-A)	Thermal Resistance (Junction to Ambient)	°C/W			833			620			550			620	
R <sub>TH</sub> (J-C)	Thermal Resistance (Junction to Case)	°C/W			200			200			200			200	

Notes:

- Electronic Industrial Association of Japan.
- Pulsed measurement, PW ≤ 350 μs, duty cycle ≤ 2%.
- The emitter terminal should be connected to the ground

terminal of the 3 terminal capacitance bridge.

**ABSOLUTE MAXIMUM RATINGS<sup>1</sup>** ( $T_A = 25^\circ\text{C}$ )

SYMBOLS	PARAMETERS	UNITS	RATINGS
V <sub>CBO</sub>	Collector to Base Voltage	V	20
V <sub>CEO</sub>	Collector to Emitter Voltage	V	10
V <sub>EBO</sub>	Emitter to Base Voltage	V	1.5
I <sub>C</sub>	Collector Current	mA	35
T <sub>J</sub>	Junction Temperature	°C	150 <sup>2</sup>
T <sub>STG</sub>	Storage Temperature	°C	-65 to +150

Notes:

1. Operation in excess of any one of these parameters may result in permanent damage.
2. Maximum T<sub>J</sub> for the NE68035 is 200°C.

**DC POWER DERATING CURVES**

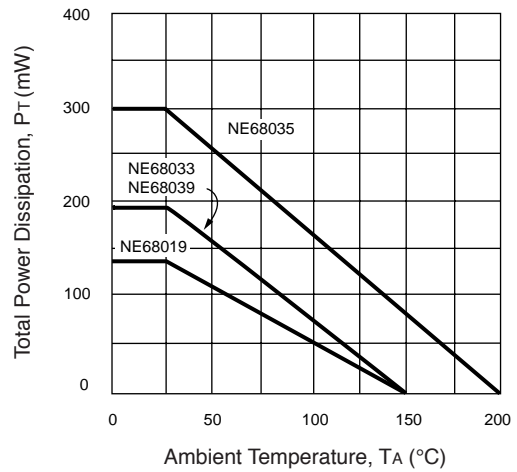

**TYPICAL PERFORMANCE CURVES** ( $T_A = 25^\circ\text{C}$ )

**NE68035**  
**INSERTION GAIN vs.**  
**COLLECTOR CURRENT**

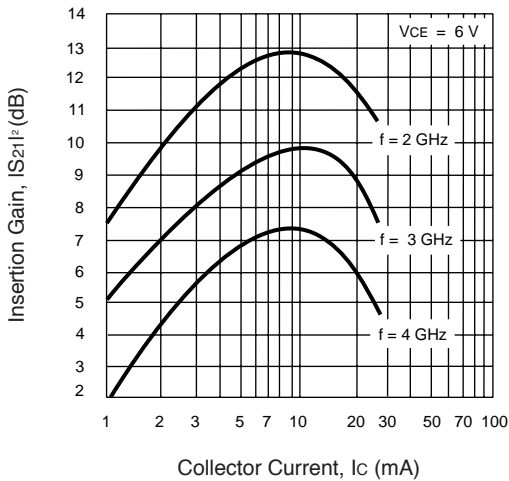

**NE68033**  
**INSERTION GAIN vs.**  
**COLLECTOR CURRENT**

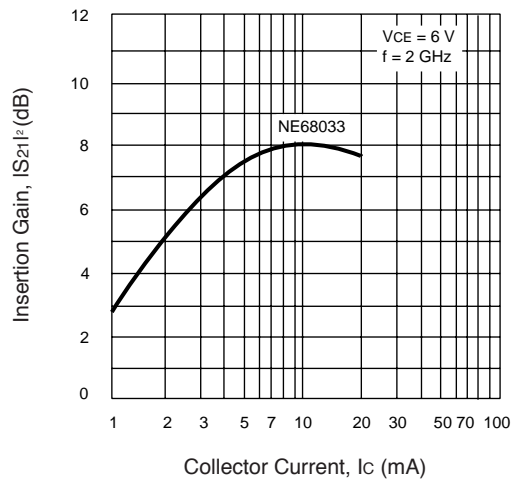

**NE68039**  
**FORWARD INSERTION GAIN**  
**AND MAXIMUM AVAILABLE**  
**GAIN vs. FREQUENCY**

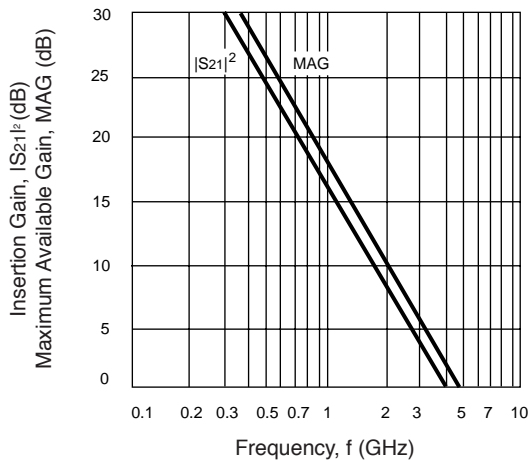

**NE68035**  
**FORWARD INSERTION GAIN**  
**AND MAXIMUM AVAILABLE**  
**GAIN vs. FREQUENCY**

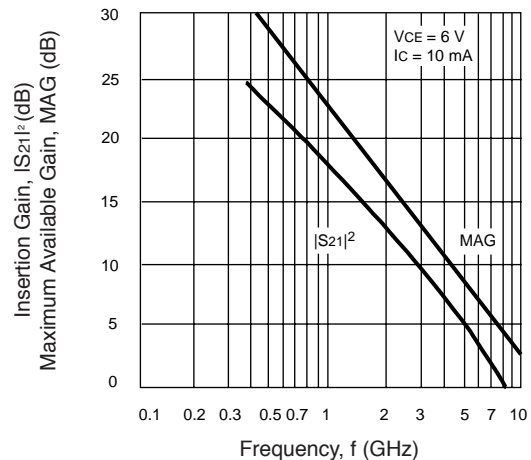

# NE680 SERIES

## TYPICAL PERFORMANCE CURVES (TA = 25°C)

**FORWARD CURRENT GAIN vs. COLLECTOR CURRENT**

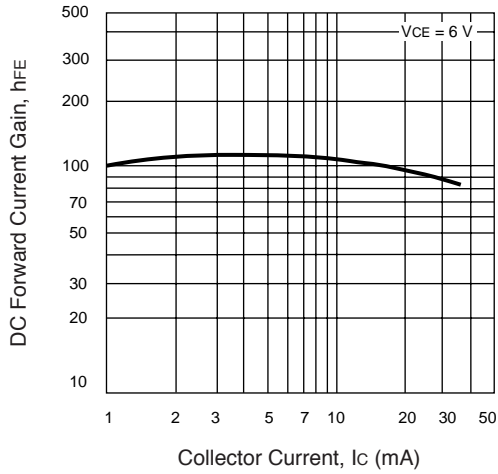

**NE68033 NOISE FIGURE vs. COLLECTOR CURRENT**

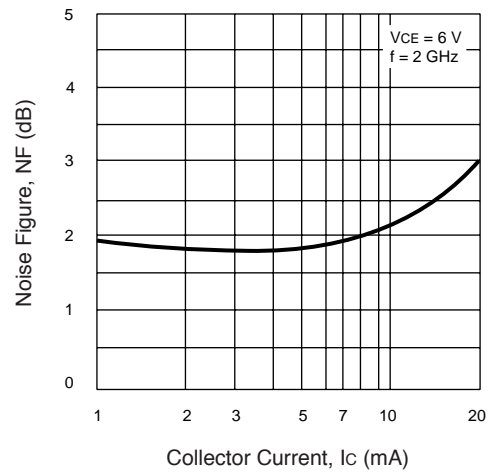

**NE68035 NOISE FIGURE vs. COLLECTOR CURRENT**

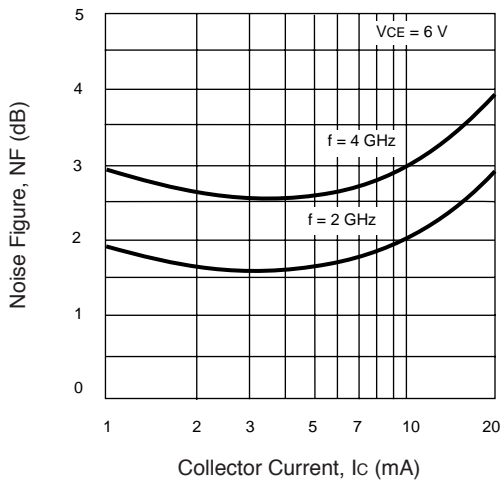

**GAIN BANDWIDTH PRODUCT vs. COLLECTOR CURRENT**

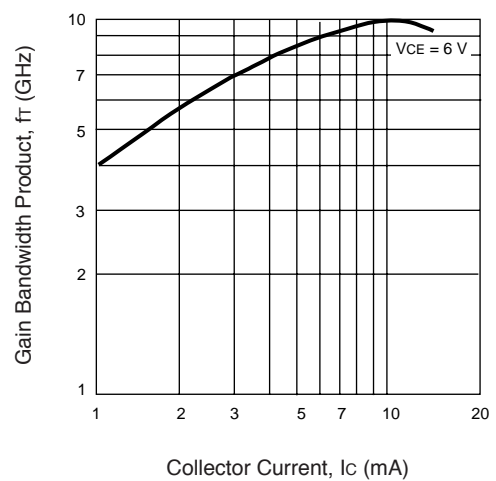

**COLLECTOR TO BASE CAPACITANCE vs. COLLECTOR TO BASE VOLTAGE**

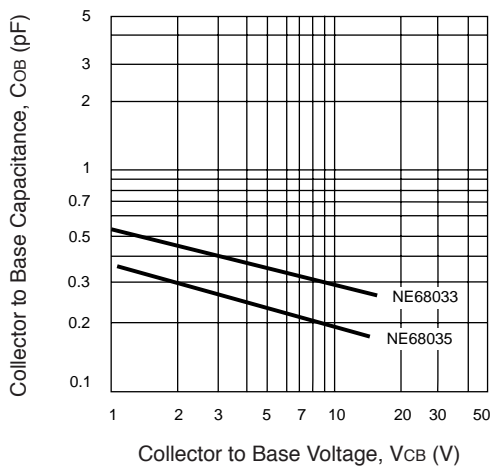

## NE68018

TYPICAL NOISE PARAMETERS ( $T_A = 25^\circ\text{C}$ )

FREQ. (MHz)	NF <sub>OPT</sub> (dB)	G <sub>A</sub> (dB)	Γ <sub>OPT</sub>		Rn/50
			MAG	ANG	
<b>V<sub>CE</sub> = 3 V, I<sub>c</sub> = 5 mA</b>					
500	1.45	20.74	0.46	22	0.41
800	1.50	17.44	0.39	44	0.32
1000	1.55	15.79	0.34	54	0.29
2000	1.90	9.96	0.24	76	0.26
3000	2.40	7.26	0.16	130	0.12
<b>V<sub>CE</sub> = 6 V, I<sub>c</sub> = 5 mA</b>					
500	1.5	21.20	.47	21	0.44
800	1.6	17.50	.38	36	0.31
1000	1.6	15.63	.44	47	0.43
2000	2.1	10.20	.32	81	0.27
3000	2.4	7.49	.19	125	0.14

## NE68019

TYPICAL NOISE PARAMETERS ( $T_A = 25^\circ\text{C}$ )

FREQ. (MHz)	NF <sub>OPT</sub> (dB)	G <sub>A</sub> (dB)	Γ <sub>OPT</sub>		Rn/50
			MAG	ANG	
<b>V<sub>CE</sub> = 3 V, I<sub>c</sub> = 5 mA</b>					
500	1.36	19.2	0.52	18	0.47
800	1.47	15.7	0.48	33	0.33
1000	1.55	14.0	0.46	41	0.31
1500	1.71	11.0	0.42	58	0.27
2000	1.88	9.0	0.32	75	0.22
2500	2.06	7.4	0.27	86	0.18
3000	2.29	6.0	0.22	103	0.12
<b>V<sub>CE</sub> = 6 V, I<sub>c</sub> = 5 mA</b>					
500	1.36	19.44	0.56	16	0.50
800	1.47	15.86	0.54	30	0.36
1000	1.55	14.16	0.52	39	0.33
1500	1.71	11.15	0.48	58	0.30
2000	1.88	9.49	0.36	77	0.27
2500	2.06	7.89	0.30	88	0.23
3000	2.29	6.74	0.24	103	0.17

## NE68035

TYPICAL NOISE PARAMETERS ( $T_A = 25^\circ\text{C}$ )

FREQ. (MHz)	NF <sub>OPT</sub> (dB)	G <sub>A</sub> (dB)	Γ <sub>OPT</sub>		Rn/50
			MAG	ANG	
<b>V<sub>CE</sub> = 6 V, I<sub>c</sub> = 5 mA</b>					
1000	1.2	19.21	0.30	65	0.37
2000	1.7	14.49	0.20	155	0.30
4000	2.6	9.12	0.22	-128	0.33

## NE68030

TYPICAL NOISE PARAMETERS ( $T_A = 25^\circ\text{C}$ )

FREQ. (MHz)	NF <sub>OPT</sub> (dB)	G <sub>A</sub> (dB)	Γ <sub>OPT</sub>		Rn/50
			MAG	ANG	
<b>V<sub>CE</sub> = 2.5 V, I<sub>c</sub> = 3 mA</b>					
500	1.32	12.79	0.79	21	1.60
800	1.48	12.59	0.72	40	1.43
1000	1.58	11.35	0.69	52	1.08
1500	1.82	5.87	0.64	64	0.92
2000	2.12	3.48	0.59	78	0.75
<b>V<sub>CE</sub> = 6 V, I<sub>c</sub> = 5 mA</b>					
1000	1.52	16.93	0.46	126	0.15
2000	1.76	10.70	0.37	-159	0.11
3000	2.25	7.56	0.36	-132	0.14
4000	2.92	5.82	0.35	-115	0.16

## NE68033

TYPICAL NOISE PARAMETERS ( $T_A = 25^\circ\text{C}$ )

FREQ. (MHz)	NF <sub>OPT</sub> (dB)	G <sub>A</sub> (dB)	Γ <sub>OPT</sub>		Rn/50
			MAG	ANG	
<b>V<sub>CE</sub> = 2.5 V, I<sub>c</sub> = 3 mA</b>					
500	1.10	18.26	0.65	21	0.56
800	1.20	14.56	0.60	32	0.42
1000	1.27	13.26	0.52	43	0.39
1500	1.43	9.80	0.47	48	0.36
2000	1.64	7.76	0.39	53	0.32
<b>V<sub>CE</sub> = 6 V, I<sub>c</sub> = 5 mA</b>					
500	1.35	19.25	0.60	17	0.60
1000	1.45	14.20	0.45	33	0.48
2000	1.70	9.18	0.22	42	0.45
3000	2.10	6.60	0.11	-4	0.40
4000	2.55	5.22	0.18	-63	0.47

## NE68039

TYPICAL NOISE PARAMETERS ( $T_A = 25^\circ\text{C}$ )

FREQ. (MHz)	NF <sub>OPT</sub> (dB)	G <sub>A</sub> (dB)	Γ <sub>OPT</sub>		Rn/50
			MAG	ANG	
<b>V<sub>CE</sub> = 2.5 V, I<sub>c</sub> = 3 mA</b>					
500	1.14	19.29	0.54	18	0.41
800	1.21	15.55	0.47	28	0.35
1000	1.26	14.04	0.42	39	0.29
1500	1.40	10.98	0.31	55	0.25
2000	1.62	9.34	0.16	97	0.19
<b>V<sub>CE</sub> = 6 V, I<sub>c</sub> = 5 mA</b>					
500	1.5	20.60	0.52	3	0.52
1000	1.6	15.91	0.38	29	0.40
2000	1.7	10.82	0.18	81	0.26
3000	2.1	8.49	0.17	-158	0.29
4000	2.6	7.21	0.40	-116	0.31

# NE680 SERIES

## TYPICAL COMMON EMITTER SCATTERING PARAMETERS (T<sub>A</sub> = 25°C)

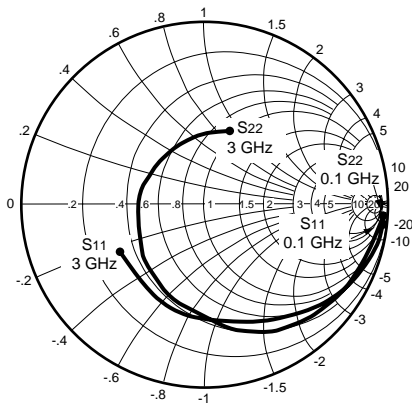

Coordinates in Ohms  
Frequency in GHz  
(V<sub>CE</sub> = 2.5 V, I<sub>C</sub> = 1 mA)

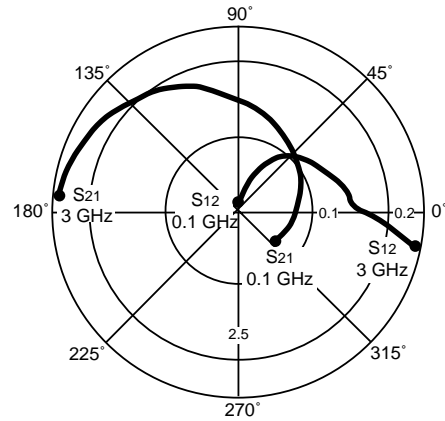

### NE68018

V<sub>CE</sub> = 2.5 V, I<sub>C</sub> = 1 mA

FREQUENCY (MHz)	S <sub>11</sub>		S <sub>21</sub>		S <sub>12</sub>		S <sub>22</sub>		K	MAG <sup>1</sup> (dB)
	MAG	ANG	MAG	ANG	MAG	ANG	MAG	ANG		
100	.972	-9.4	3.605	170.2	.017	81.6	.995	-3.5	0.12	23.3
400	.907	-34.2	3.315	146.5	.061	65.5	.966	-20.2	0.19	17.4
800	.778	-65.1	2.897	118.1	.104	45.6	.874	-37.5	0.35	14.4
1000	.706	-78.9	2.678	105.8	.114	38.1	.841	-44.3	0.42	13.7
1500	.561	-111.0	2.173	78.7	.135	21.4	.755	-58.4	0.65	12.1
2000	.457	-139.5	1.800	56.6	.147	11.8	.712	-70.4	0.82	10.9
2500	.389	-166.6	1.545	37.3	.145	4.8	.668	-80.5	1.08	8.5
3000	.356	167.0	1.358	20.7	.150	2.4	.651	-90.6	1.20	6.9

V<sub>CE</sub> = 2.5 V, I<sub>C</sub> = 3 mA

100	.884	-12.9	9.246	166.6	.018	77.7	.964	-8.5	0.19	27.1
400	.729	-52.2	7.715	132.3	.056	58.5	.864	-27.8	0.34	21.4
800	.507	-90.1	5.509	101.2	.073	41.2	.704	-43.7	0.63	18.8
1000	.430	-105.8	4.722	89.8	.087	38.3	.657	-48.3	0.71	17.3
1500	.312	-138.0	3.398	66.8	.110	35.6	.591	-58.8	0.88	14.9
2000	.259	-167.5	2.645	48.2	.120	27.1	.561	-69.0	1.07	11.8
2500	.231	164.8	2.189	31.5	.137	23.2	.544	-78.5	1.15	9.7
3000	.223	139.5	1.876	16.9	.165	18.5	.539	-87.7	1.13	8.4

V<sub>CE</sub> = 6 V, I<sub>C</sub> = 5 mA

100	.838	-17.7	13.662	163.3	.012	80.3	.965	-9.5	0.13	30.6
400	.610	-61.4	10.216	124.3	.037	61.1	.819	-28.3	0.42	24.4
800	.381	-99.4	6.605	94.4	.063	48.9	.661	-40.1	0.73	20.2
1000	.314	-114.8	5.516	83.9	.067	47.8	.630	-43.7	0.85	19.2
1500	.223	-149.1	3.855	63.0	.092	43.1	.587	-54.1	0.97	16.2
2000	.188	-178.0	2.963	45.9	.112	34.0	.569	-63.6	1.07	12.6
2500	.185	153.8	2.417	30.3	.130	33.0	.567	-72.1	1.10	10.8
3000	.173	129.0	2.063	16.4	.155	23.5	.563	-82.5	1.10	9.3

Note:

1. Gain Calculations:

$$\text{MAG} = \frac{|S_{21}|}{|S_{12}|} \left( K \pm \sqrt{K^2 - 1} \right). \text{ When } K \leq 1, \text{ MAG is undefined and MSG values are used. } \text{MSG} = \frac{|S_{21}|}{|S_{12}|}, K = \frac{1 + |\Delta|^2 - |S_{11}|^2 - |S_{22}|^2}{2 |S_{12}| |S_{21}|}, \Delta = S_{11} S_{22} - S_{21} S_{12}$$

MAG = Maximum Available Gain

MSG = Maximum Stable Gain

TYPICAL COMMON EMITTER SCATTERING PARAMETERS (T<sub>A</sub> = 25°C)

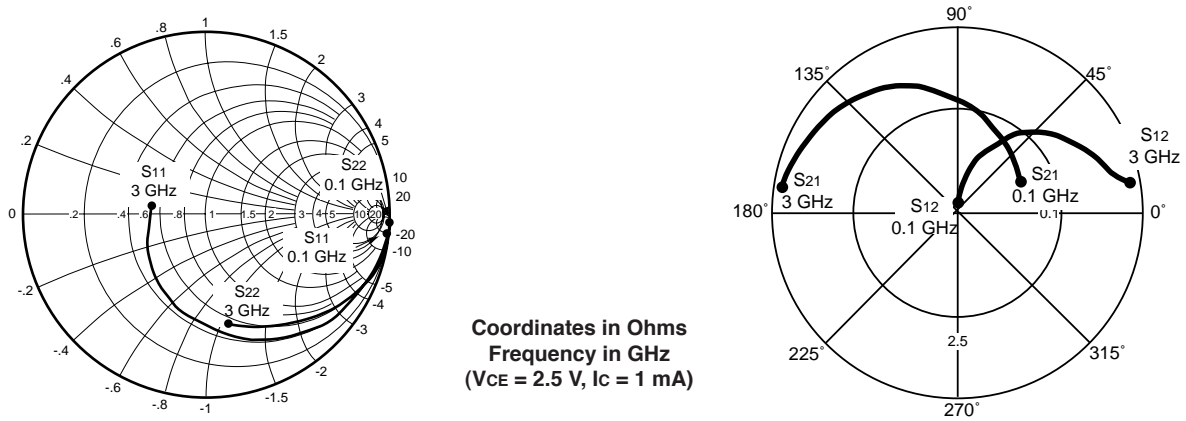

NE68019

V<sub>CE</sub> = 2.5 V, I<sub>C</sub> = 1 mA

FREQUENCY (MHz)	S <sub>11</sub>		S <sub>21</sub>		S <sub>12</sub>		S <sub>22</sub>		K	MAG <sup>1</sup> (dB)
	MAG	ANG	MAG	ANG	MAG	ANG	MAG	ANG		
100	.971	-9.9	3.456	169.4	.017	84.6	0.996	-6.2	0.03	23.1
400	.905	-34.9	3.207	145.8	.064	66.7	0.961	-20.2	0.17	17.0
800	.774	-65.1	2.751	117.3	.110	46.1	0.869	-36.6	0.37	14.0
1000	.706	-78.0	2.512	105.2	.126	38.1	0.829	-43.1	0.46	13.0
1500	.564	-106.1	2.043	80.0	.146	25.4	0.751	-54.7	0.68	11.5
2000	.453	-130.7	1.721	59.1	.155	17.5	0.695	-63.8	0.90	10.5
2500	.364	-156.6	1.497	40.9	.162	13.5	0.658	-71.6	1.08	7.9
3000	.303	174.5	1.355	24.5	.176	9.9	0.624	-79.9	1.19	6.2

V<sub>CE</sub> = 2.5 V, I<sub>C</sub> = 3 mA

100	.905	-15.3	9.292	165.2	.018	81.0	.968	-9.4	0.10	27.1
400	.726	-52.5	7.492	131.0	.057	60.9	.848	-28.7	0.34	21.2
800	.505	-87.4	5.221	100.5	.083	46.2	.684	-42.7	0.63	18.0
1000	.428	-100.0	4.439	89.5	.093	42.5	.638	-46.9	0.75	16.8
1500	.302	-126.3	3.211	67.8	.116	36.3	.582	-54.4	0.95	14.4
2000	.223	-149.5	2.520	50.2	.138	33.0	.551	-61.4	1.08	10.9
2500	.172	-177.0	2.100	34.7	.163	28.4	.532	-67.6	1.13	8.9
3000	.149	150.7	1.831	20.4	.191	22.6	.507	-75.5	1.15	7.5

V<sub>CE</sub> = 6 V, I<sub>C</sub> = 5 mA

100	.849	-18.0	13.629	162.0	.018	85.2	.949	-9.6	0.11	28.8
400	.613	-60.8	9.820	123.1	.050	60.7	.789	-29.4	0.45	22.9
800	.386	-93.9	6.206	93.8	.067	49.2	.639	-39.2	0.79	19.7
1000	.317	-105.5	5.157	83.9	.079	47.3	.607	-42.2	0.87	18.1
1500	.215	-128.5	3.615	64.1	.102	43.3	.575	-49.1	1.02	14.6
2000	.149	-149.7	2.786	47.9	.127	39.9	.563	-55.7	1.09	11.6
2500	.103	-178.6	2.298	33.5	.156	34.0	.552	-62.3	1.10	9.80
3000	.092	143.3	1.989	20.1	.185	28.9	.537	-70.2	1.10	8.40

Note:

1. Gain Calculations:

$$MAG = \frac{|S_{21}|}{|S_{12}|} (K \pm \sqrt{K^2 - 1})$$

When  $K \leq 1$ , MAG is undefined and MSG values are used.  $MSG = \frac{|S_{21}|}{|S_{12}|}$ ,  $K = \frac{1 + |\Delta|^2 - |S_{11}|^2 - |S_{22}|^2}{2 |S_{12}| |S_{21}|}$ ,  $\Delta = S_{11} S_{22} - S_{21} S_{12}$

MAG = Maximum Available Gain

MSG = Maximum Stable Gain

# NE680 SERIES

## TYPICAL COMMON EMITTER SCATTERING PARAMETERS (T<sub>A</sub> = 25°C)

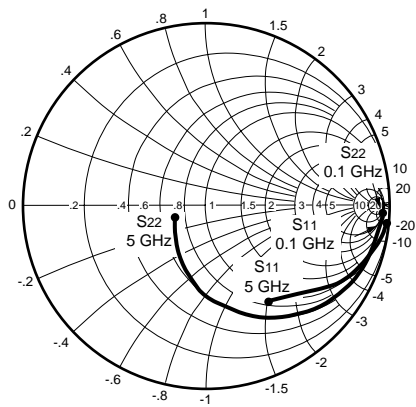

Coordinates in Ohms  
Frequency in GHz  
(V<sub>CE</sub> = 2.5 V, I<sub>C</sub> = 1 mA)

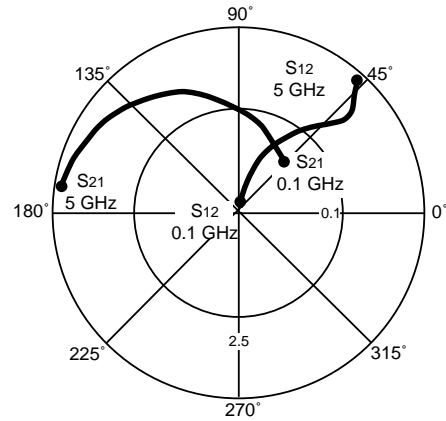

### NE68030

V<sub>CE</sub> = 2.5 V, I<sub>C</sub> = 1 mA

FREQUENCY (MHz)	S <sub>11</sub>		S <sub>21</sub>		S <sub>12</sub>		S <sub>22</sub>		K	MAG <sup>1</sup> (dB)
	MAG	ANG	MAG	ANG	MAG	ANG	MAG	ANG		
100	.958	-8.2	3.592	171.5	.018	82.5	.988	-4.2	0.11	23.0
400	.907	-31.4	3.325	148.1	.065	70.1	.949	-16.3	0.21	17.1
800	.752	-57.5	2.807	121.4	.107	55.3	.860	-28.7	0.42	14.2
1000	.672	-68.0	2.541	110.8	.122	50.3	.814	-33.2	0.53	13.2
1500	.500	-90.6	2.058	89.1	.147	43.4	.727	-40.7	0.77	11.5
2000	.371	-108.7	1.705	71.5	.157	41.1	.687	-46.7	0.99	10.4
2500	.257	-129.3	1.479	57.1	.173	43.5	.658	-51.7	1.13	7.1
3000	.172	-154.1	1.331	45.0	.194	46.5	.638	-56.6	1.18	5.8

V<sub>CE</sub> = 2.5 V, I<sub>C</sub> = 3 mA

100	.907	-14.6	9.563	166.7	.018	75.1	.983	-8.1	0.19	27.3
400	.706	-47.3	7.296	131.3	.056	64.8	.832	-23.2	0.43	21.1
800	.461	-72.5	4.915	103.2	.084	57.3	.687	-31.8	0.74	17.7
1000	.382	-80.6	4.154	93.9	.098	56.6	.646	-34.3	0.83	16.3
1500	.238	-95.8	2.979	76.9	.131	56.1	.585	-37.7	1.00	13.6
2000	.155	-101.6	2.324	62.8	.159	54.7	.579	-42.2	1.08	9.9
2500	.078	-107.6	1.940	51.3	.194	54.2	.570	-47.0	1.09	8.2
3000	.026	-102.4	1.679	41.5	.230	51.9	.561	-51.8	1.09	6.8

V<sub>CE</sub> = 6 V, I<sub>C</sub> = 10 mA

100	.769	-21.7	20.130	156.0	.015	80.5	.936	-10.5	0.25	31.3
400	.403	-60.5	11.063	113.0	.039	69.4	.679	-20.7	0.77	24.5
600	.281	-70.3	7.969	100.1	.052	70.5	.623	-21.3	0.91	21.9
800	.209	-75.2	6.153	91.4	.067	71.0	.594	-22.3	0.98	19.6
1000	.158	-77.4	4.995	84.2	.079	70.8	.582	-23.3	1.04	16.8
1200	.129	-81.3	4.190	78.8	.096	72.2	.564	-26.1	1.05	15.0
1400	.087	-81.5	3.651	74.3	.112	70.8	.551	-26.6	1.06	13.6
1600	.062	-77.2	3.247	69.3	.129	69.3	.556	-28.7	1.05	12.6
1800	.041	-71.7	2.915	64.9	.142	68.2	.555	-30.6	1.05	11.8
2000	.025	-76.9	2.655	60.6	.157	66.5	.555	-32.9	1.05	10.9
2500	.022	34.5	2.171	51.5	.192	63.8	.549	-38.7	1.05	9.2
3000	.048	59.7	1.874	43.0	.229	61.2	.542	-43.8	1.03	8.1
3500	.080	65.8	1.658	35.3	.270	58.0	.530	-50.4	1.01	7.3
4000	.126	68.2	1.514	28.0	.314	53.3	.514	-57.6	0.98	6.8
4500	.161	70.1	1.411	20.7	.357	49.4	.478	-66.2	0.97	6.0
5000	.232	68.1	1.330	13.9	.406	45.0	.426	-76.0	0.95	5.2

Note:

1. Gain Calculations:

$$MAG = \frac{|S_{21}|}{|S_{12}|} \left( K \pm \sqrt{K^2 - 1} \right). \text{ When } K \leq 1, \text{ MAG is undefined and MSG values are used. } MSG = \frac{|S_{21}|}{|S_{12}|}, K = \frac{1 + |\Delta|^2 - |S_{11}|^2 - |S_{22}|^2}{2 |S_{12}| |S_{21}|}, \Delta = S_{11} S_{22} - S_{21} S_{12}$$

MAG = Maximum Available Gain

MSG = Maximum Stable Gain



TYPICAL COMMON EMITTER SCATTERING PARAMETERS (T<sub>A</sub> = 25°C)

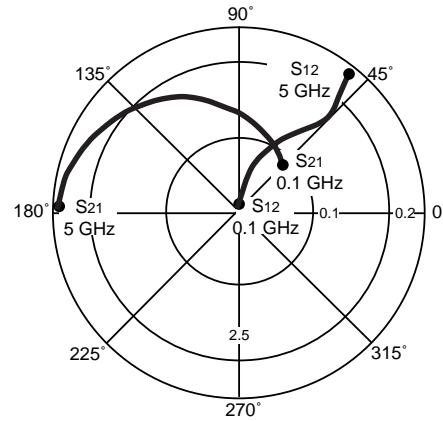
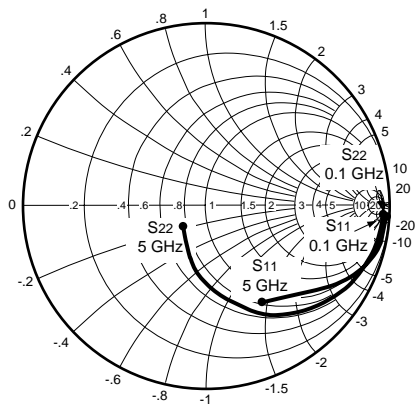

Coordinates in Ohms  
Frequency in GHz  
(V<sub>CE</sub> = 2.5 V, I<sub>C</sub> = 1 mA)

NE68033

V<sub>CE</sub> = 2.5 V, I<sub>C</sub> = 1 mA

FREQUENCY (MHz)	S <sub>11</sub>		S <sub>21</sub>		S <sub>12</sub>		S <sub>22</sub>		K	MAG <sup>1</sup> (dB)
	MAG	ANG	MAG	ANG	MAG	ANG	MAG	ANG		
100	.967	-8.2	3.635	170.6	.019	81.5	.990	-4.1	0.14	22.8
400	.903	-29.4	3.254	147.9	.069	71.0	.948	-16.8	0.23	16.7
800	.732	-53.1	2.758	121.3	.116	56.2	.846	-29.0	0.48	13.8
1000	.658	-62.8	2.508	110.3	.131	51.9	.801	-33.5	0.58	12.8
1500	.478	-83.0	2.043	88.2	.154	46.9	.715	-41.4	0.82	11.2
2000	.349	-100.5	1.708	71.1	.173	46.2	.663	-47.5	1.00	9.9
2500	.242	-114.6	1.507	56.5	.194	48.6	.633	-53.4	1.10	7.0
3000	.155	-136.7	1.371	44.6	.227	50.9	.609	-59.7	1.11	5.8

V<sub>CE</sub> = 2.5 V, I<sub>C</sub> = 3 mA

100	.906	-13.9	9.367	165.4	.019	84.5	.972	-7.4	0.1	26.9
400	.704	-43.9	7.037	130.3	.058	65.0	.821	-23.5	0.48	20.8
800	.448	-64.8	4.712	103.1	.093	60.4	.670	-31.2	0.78	17.0
1000	.370	-71.3	3.960	93.7	.106	59.8	.632	-33.1	0.88	15.7
1500	.241	-80.5	2.864	76.6	.144	59.3	.582	-37.1	1.00	13.0
2000	.167	-85.7	2.263	63.0	.181	58.0	.563	-41.8	1.05	9.6
2500	.104	-81.4	1.916	51.6	.221	56.3	.552	-47.0	1.06	7.9
3000	.065	-78.4	1.700	41.6	.264	53.4	.541	-53.3	1.03	7.0

V<sub>CE</sub> = 6 V, I<sub>C</sub> = 10 mA

50	.817	-10.6	21.366	168.2	.006	85.7	.974	-5.5	0.13	35.5
100	.769	-21.7	20.130	156.0	.015	80.5	.936	-10.5	0.25	31.3
200	.628	-40.1	16.661	136.5	.024	71.6	.826	-17.6	0.48	28.4
400	.403	-60.5	11.063	113.0	.039	69.4	.679	-20.7	0.77	24.5
600	.281	-70.3	7.969	100.1	.052	70.5	.623	-21.3	0.91	21.9
800	.209	-75.2	6.153	91.4	.067	71.0	.594	-22.3	0.98	19.6
1000	.158	-77.4	4.995	84.2	.079	70.8	.582	-23.3	1.04	16.8
1200	.129	-81.3	4.190	78.8	.096	72.2	.564	-26.1	1.05	15.0
1400	.087	-81.5	3.651	74.3	.112	70.8	.551	-26.6	1.06	13.6
1600	.062	-77.2	3.247	69.3	.129	69.3	.556	-28.7	1.05	12.6
1800	.041	-71.7	2.915	64.9	.142	68.2	.555	-30.6	1.05	11.8
2000	.025	-76.9	2.655	60.6	.157	66.5	.555	-32.9	1.05	10.9
2500	.022	34.5	2.171	51.5	.192	63.8	.549	-38.7	1.05	9.2
3000	.048	59.7	1.874	43.0	.229	61.2	.542	-43.8	1.03	8.1
3500	.080	65.8	1.658	35.3	.270	58.0	.530	-50.4	1.01	7.3
4000	.126	68.2	1.514	28.0	.314	53.3	.514	-57.6	0.98	6.8
4500	.161	70.1	1.411	20.7	.357	49.4	.478	-66.2	0.97	6.0
5000	.232	68.1	1.330	13.9	.406	45.0	.426	-76.0	0.95	5.2

Note:

1. Gain Calculations:

$$MAG = \frac{|S_{21}|}{|S_{12}|} \left( K \pm \sqrt{K^2 - 1} \right). \text{ When } K \leq 1, \text{ MAG is undefined and MSG values are used. } MSG = \frac{|S_{21}|}{|S_{12}|}, K = \frac{1 + |\Delta|^2 - |S_{11}|^2 - |S_{22}|^2}{2 |S_{12}| |S_{21}|}, \Delta = S_{11} S_{22} - S_{21} S_{12}$$

MAG = Maximum Available Gain

MSG = Maximum Stable Gain

# NE680 SERIES

## TYPICAL COMMON EMITTER SCATTERING PARAMETERS (T<sub>A</sub> = 25°C)

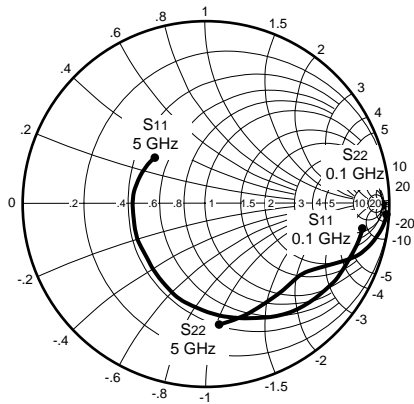

Coordinates in Ohms  
Frequency in GHz  
(V<sub>CE</sub> = 6 V, I<sub>c</sub> = 5 mA)

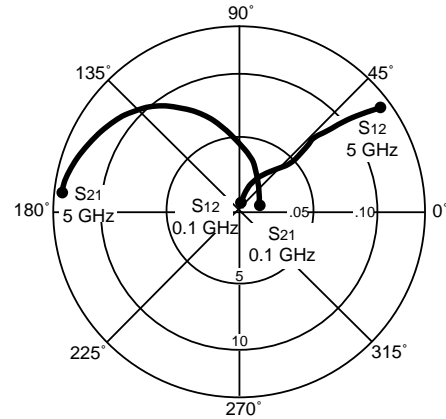

### NE68035

V<sub>CE</sub> = 6 V, I<sub>c</sub> = 5 mA

FREQUENCY (MHz)	S <sub>11</sub>		S <sub>21</sub>		S <sub>12</sub>		S <sub>22</sub>		K	MAG <sup>1</sup> (dB)
	MAG	ANG	MAG	ANG	MAG	ANG	MAG	ANG		
100	.869	-13.4	12.862	167.5	.009	83.8	.989	-5.8	0.07	31.4
500	.682	-69.0	9.959	128.3	.034	55.9	.834	-22.2	0.36	24.6
1000	.518	-111.7	6.550	100.6	.047	45.2	.706	-30.0	0.64	21.4
1500	.440	-137.9	4.709	83.9	.056	43.5	.658	-35.4	0.85	19.3
2000	.414	-156.8	3.658	70.8	.064	43.2	.642	-41.5	0.98	17.6
2500	.400	-171.6	3.004	59.6	.073	43.2	.637	-48.0	1.04	14.9
3000	.392	175.7	2.527	49.3	.083	42.8	.639	-55.0	1.08	13.1
3500	.385	164.5	2.182	39.8	.093	41.9	.646	-62.2	1.10	11.8
4000	.382	155.2	1.973	30.9	.103	40.4	.654	-69.4	1.08	11.0
4500	.376	146.2	1.733	22.3	.114	38.9	.664	-76.7	1.07	10.3
5000	.372	137.8	1.575	14.0	.126	37.0	.675	-83.7	1.03	9.9

V<sub>CE</sub> = 6 V, I<sub>c</sub> = 10 mA

100	.766	-23.2	20.629	162.3	.008	75.9	.972	-8.0	0.16	33.9
500	.534	-96.2	12.610	115.8	.027	53.3	.746	-22.7	0.52	26.8
1000	.434	-138.0	7.284	91.5	.037	50.8	.649	-27.2	0.84	23.0
1500	.401	-160.0	5.035	77.3	.046	52.5	.625	-32.3	1.02	19.6
2000	.397	-174.9	3.852	65.7	.057	53.2	.619	-38.6	1.07	16.6
2500	.394	173.1	3.133	55.4	.068	52.7	.622	-45.5	1.09	14.8
3000	.396	162.7	2.626	45.8	.079	51.7	.627	-52.7	1.09	13.4
3500	.393	153.2	2.261	36.7	.091	50.0	.637	-60.1	1.07	12.3
4000	.394	145.2	2.000	28.2	.103	47.6	.648	-67.5	1.04	11.7
4500	.392	137.3	1.785	19.8	.115	45.3	.660	-75.0	1.01	11.3
5000	.391	129.4	1.619	11.7	.128	42.8	.672	-82.1	0.97	11.0

V<sub>CE</sub> = 6 V, I<sub>c</sub> = 20 mA

100	.593	-45.9	25.683	152.5	.008	73.6	.933	-9.6	0.20	35.3
500	.463	-132.6	11.309	103.7	.019	54.1	.713	-18.0	0.80	27.7
1000	.443	-163.8	6.056	83.9	.029	58.6	.672	-22.6	1.09	21.4
1500	.436	-178.8	4.124	71.6	.039	61.6	.664	-29.1	1.21	17.5
2000	.443	170.3	3.140	60.8	.051	62.0	.665	-36.5	1.20	15.2
2500	.448	160.8	2.547	50.9	.062	61.3	.670	-44.1	1.18	13.6
3000	.453	152.3	2.132	41.5	.074	60.0	.677	-52.0	1.13	12.4
3500	.454	144.1	1.832	32.5	.087	58.0	.687	-59.9	1.09	11.4
4000	.459	136.7	1.618	24.0	.099	55.4	.697	-67.8	1.03	11.1
4500	.460	129.2	1.441	15.7	.112	52.9	.708	-75.7	0.98	11.1
5000	.461	121.6	1.304	7.7	.127	50.2	.718	-83.1	0.92	10.1

Note:

1. Gain Calculations:

$$\text{MAG} = \frac{|S_{21}|}{|S_{12}|} (K \pm \sqrt{K^2 - 1}). \text{ When } K \leq 1, \text{ MAG is undefined and MSG values are used. } \text{MSG} = \frac{|S_{21}|}{|S_{12}|}, K = \frac{1 + |\Delta|^2 - |S_{11}|^2 - |S_{22}|^2}{2 |S_{12}| |S_{21}|}, \Delta = S_{11} S_{22} - S_{21} S_{12}$$

MAG = Maximum Available Gain

MSG = Maximum Stable Gain

TYPICAL COMMON EMITTER SCATTERING PARAMETERS (T<sub>A</sub> = 25°C)

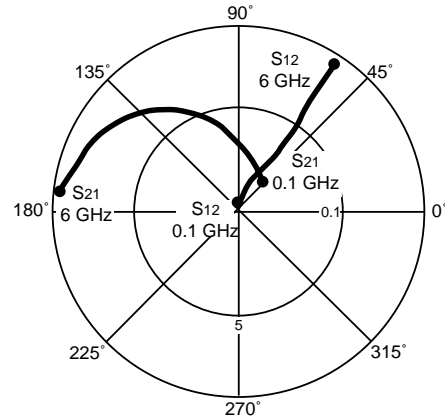
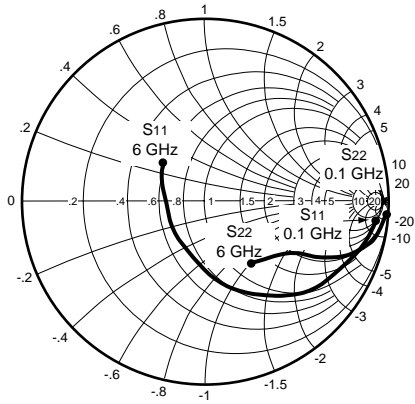

Coordinates in Ohms  
Frequency in GHz  
(V<sub>CE</sub> = 2.5 V, I<sub>C</sub> = 3 mA)

NE68039

V<sub>CE</sub> = 2.5 V, I<sub>C</sub> = 3 mA

FREQUENCY (MHz)	S <sub>11</sub>		S <sub>21</sub>		S <sub>12</sub>		S <sub>22</sub>		K	MAG <sup>1</sup> (dB)
	MAG	ANG	MAG	ANG	MAG	ANG	MAG	ANG		
50	0.935	-5.8	9.685	173.9	0.007	83.3	0.990	-3.7	0.11	31.4
100	0.903	-15.3	9.393	168.4	0.015	79.8	0.984	-6.0	0.10	28.0
200	0.826	-26.3	8.809	154.7	0.028	72.7	0.951	-11.7	0.25	25.0
300	0.770	-38.7	8.225	144.2	0.039	68.7	0.899	-16.2	0.31	23.2
400	0.690	-49.6	7.593	134.7	0.051	64.6	0.850	-19.6	0.40	21.7
500	0.618	-58.1	6.894	126.4	0.060	62.3	0.806	-21.9	0.48	20.6
600	0.545	-67.5	6.290	119.4	0.067	59.4	0.759	-24.0	0.56	19.7
800	0.436	-83.4	5.266	107.3	0.079	56.5	0.689	-26.3	0.70	18.2
1000	0.353	-98.2	4.489	98.4	0.089	56.3	0.638	-27.6	0.81	17.0
1500	0.232	-138.6	3.270	80.4	0.114	56.3	0.555	-31.2	0.99	14.6
2000	0.217	-177.0	2.573	66.5	0.138	57.7	0.502	-36.5	1.08	11.0
2500	0.262	154.2	2.148	54.6	0.168	57.2	0.456	-43.4	1.08	9.3
3000	0.314	136.1	1.860	44.2	0.201	56.8	0.423	-53.6	1.05	8.3

V<sub>CE</sub> = 6 V, I<sub>C</sub> = 3 mA

100	0.918	-10	8.888	168	0.001	81	0.989	-5	0.29	39.5
200	0.891	-22	8.546	158	0.003	76	0.981	-8	0.26	34.5
400	0.757	-41	7.606	141	0.024	71	0.915	-14	0.32	25.0
600	0.634	-55	6.430	125	0.045	65	0.822	-18	0.54	21.5
800	0.511	-68	5.638	115	0.057	62	0.757	-20	0.69	20.0
1000	0.405	-78	4.839	105	0.073	61	0.700	-22	0.80	18.2
2000	0.225	-136	2.601	77	0.121	59	0.583	-29	1.09	11.5
3000	0.242	145	2.033	50	0.171	58	0.499	-41	1.07	9.1
4000	0.359	117	1.655	31	0.226	54	0.434	-64	1.00	8.6
5000	0.452	101	1.370	14	0.282	47	0.423	-91	0.92	6.9
6000	0.536	91	1.172	0	0.340	41	0.420	-116	0.84	5.4

V<sub>CE</sub> = 6 V, I<sub>C</sub> = 10 mA

100	0.756	-21	20.155	156	0.001	122	0.945	-9	0.27	36.1
200	0.647	-40	17.163	140	0.001	82	0.887	-13	0.47	34.0
400	0.423	-65	12.024	118	0.009	71	0.774	-16	1.55	26.8
600	0.301	-77	8.762	104	0.019	68	0.691	-16	1.50	22.4
800	0.211	-92	6.962	97	0.035	68	0.643	-16	1.28	19.9
1000	0.143	-108	5.674	89	0.051	71	0.614	-17	1.18	17.9
2000	0.127	146	3.089	66	0.113	69	0.551	-24	1.09	12.5
3000	0.251	120	2.207	46	0.179	64	0.477	-37	1.01	10.3
4000	0.371	107	1.768	30	0.240	57	0.407	-60	0.94	8.7
5000	0.462	95	1.471	13	0.298	49	0.392	-88	0.87	6.9
6000	0.543	87	1.247	-1	0.354	41	0.389	-114	0.82	5.5

Note:

1. Gain Calculations:

$$MAG = \frac{|S_{21}|}{|S_{12}|} (K \pm \sqrt{K^2 - 1})$$

When  $K \leq 1$ , MAG is undefined and MSG values are used.  $MSG = \frac{|S_{21}|}{|S_{12}|}$ ,  $K = \frac{1 + |\Delta|^2 - |S_{11}|^2 - |S_{22}|^2}{2 |S_{12}| |S_{21}|}$ ,  $\Delta = S_{11} S_{22} - S_{21} S_{12}$

MAG = Maximum Available Gain

MSG = Maximum Stable Gain

NE68018 NONLINEAR MODEL

SCHEMATIC

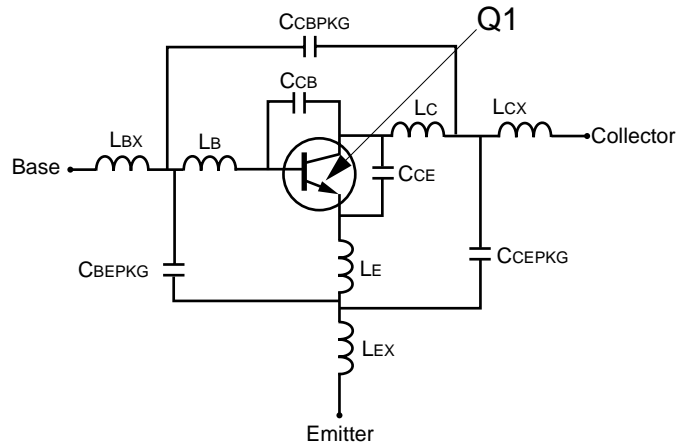

BJT NONLINEAR MODEL PARAMETERS (1)

Parameters	Q1	Parameters	Q1
IS	3.84e-16	MJC	0.64
BF	124.9	XCJC	0
NF	1.05	CJS	0
VAF	11.9	VJS	0.75
IKF	0.027	MJS	0
ISE	1.0e-14	FC	0.5
NE	2.17	TF	8.7e-12
BR	1	XTF	18
NR	1.05	VTF	19.1
VAR	Infinity	ITF	0.082
IKR	Infinity	PTF	0
ISC	0	TR	0.635e-9
NC	2	EG	1.11
RE	0.6	XTB	0
RB	17.9	XTI	3
RBM	1.02	KF	0
IRB	4.01e-4	AF	1
RC	10.46		
CJE	0.358e-12		
VJE	0.71		
MJE	0.5		
CJC	0.162e-12		
VJC	0.79		

(1) Gummel-Poon Model

UNITS

Parameter	Units
time	seconds
capacitance	farads
inductance	henries
resistance	ohms
voltage	volts
current	amps

ADDITIONAL PARAMETERS

Parameters	68018
CCB	0.08e-12
CCE	0.08e-12
LB	1.38e-9
Lc	2.55e-9
LE	0.85e-9
CCBPKG	0.14e-12
CCEPKG	0.58e-12
CBEPK	0.29e-12
LBX	0.18e-9
LCX	0.47e-9
LEX	0.09e-9

MODEL RANGE

Frequency: 0.05 to 5.0 GHz  
 Bias: VCE = 1 V to 6 V, Ic = 1 mA to 15 mA  
 Date: 5/31/96

NE68019 NONLINEAR MODEL

SCHEMATIC

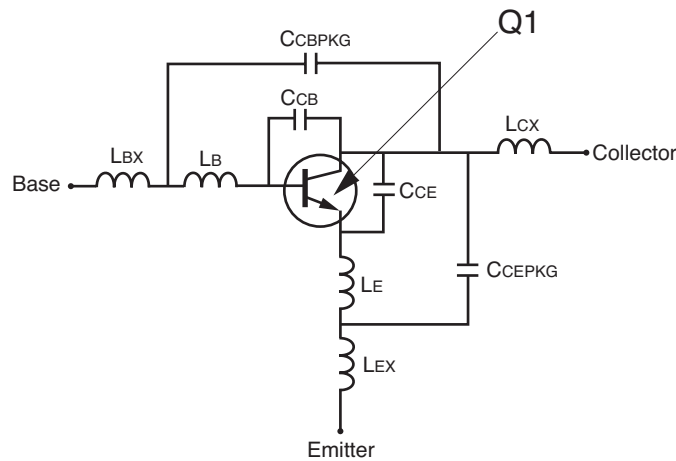

BJT NONLINEAR MODEL PARAMETERS (1)

Parameters	Q1	Parameters	Q1
IS	3.84e-16	MJC	0.64
BF	124.9	XCJC	0
NF	1.05	CJS	0
VAF	11.9	VJS	0.75
IKF	0.027	MJS	0
ISE	1.0e-14	FC	0.5
NE	2.17	TF	8.7e-12
BR	1	XTF	18
NR	1.05	VTF	19.1
VAR	Infinity	ITF	0.082
IKR	Infinity	PTF	0
ISC	0	TR	0.635e-9
NC	2	EG	1.11
RE	0.6	XTB	0
RB	17.9	XTI	3
RBM	1.02	KF	0
IRB	4.01e-4	AF	1
RC	10.5		
CJE	0.358e-12		
VJE	0.71		
MJE	0.5		
CJC	0.162e-12		
VJC	0.79		

(1) Gummel-Poon Model

UNITS

Parameter	Units
time	seconds
capacitance	farads
inductance	henries
resistance	ohms
voltage	volts
current	amps

ADDITIONAL PARAMETERS

Parameters	68019
CCB	0.08e-12
CCE	0.08e-12
LB	0.72e-9
LE	0.76e-9
CCBPKG	0.17e-12
CCEPKG	0.21e-12
LBX	0.19e-9
LCX	0.19e-9
LEX	0.19e-9

MODEL RANGE

Frequency: 0.05 to 3.0 GHz  
 Bias: VCE = 1 V to 6 V, IC = 1 mA to 15 mA  
 Date: 8/03

SCHEMATIC

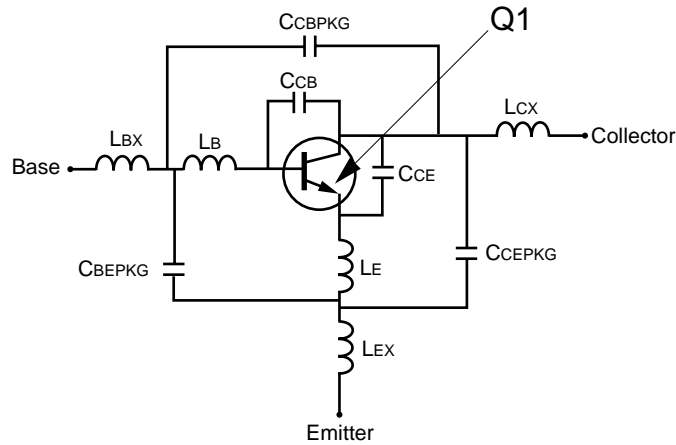

BJT NONLINEAR MODEL PARAMETERS (1)

Parameters	Q1	Parameters	Q1
IS	3.84e-16	MJC	0.64
BF	124.9	XCJC	0
NF	1.05	CJS	0
VAF	11.9	VJS	0.75
IKF	0.027	MJS	0
ISE	1.0e-14	FC	0.5
NE	2.17	TF	8.7e-12
BR	1	XTF	18
NR	1.05	VTF	19.1
VAR	Infinity	ITF	0.082
IKR	Infinity	PTF	0
ISC	0	TR	0.635e-9
NC	2	EG	1.11
RE	0.6	XTB	0
RB	17.9	XTI	3
RBM	1.02	KF	0
IRB	4.01e-4	AF	1
RC	10.5		
CJE	0.358e-12		
VJE	0.71		
MJE	0.5		
CJC	0.162e-12		
VJC	0.79		

(1) Gummel-Poon Model

UNITS

Parameter	Units
time	seconds
capacitance	farads
inductance	henries
resistance	ohms
voltage	volts
current	amps

ADDITIONAL PARAMETERS

Parameters	68030
CCB	0.08e-12
CCE	0.08e-12
LB	0.7e-9
LE	1e-9
CCBPKG	0.12e-12
CCEPKG	0.16e-12
CBEPKG	0.04e-12
LBX	0.2e-9
LCX	0.2e-9
LEX	0.2e-9

MODEL RANGE

Frequency: 0.05 to 3.0 GHz  
 Bias: VCE = 2.5 V to 6 V, IC = 1 mA to 15 mA  
 Date: 10/25/96

## NE68033 NONLINEAR MODEL

## SCHEMATIC

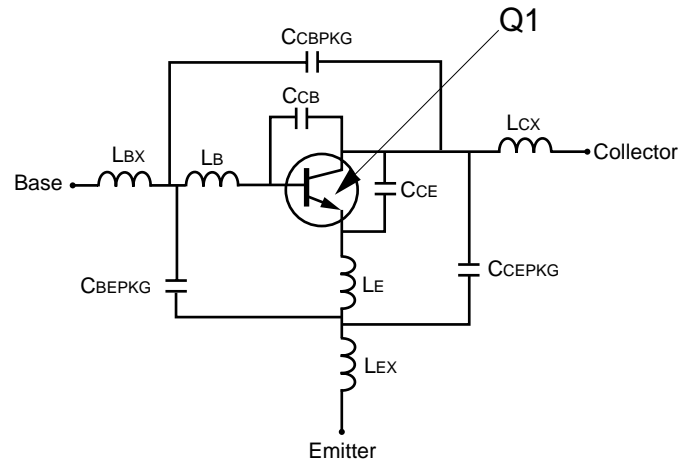
BJT NONLINEAR MODEL PARAMETERS <sup>(1)</sup>

Parameters	Q1	Parameters	Q1
IS	3.84e-16	MJC	0.64
BF	124.9	XCJC	0
NF	1.05	CJS	0
VAF	11.9	VJS	0.75
IKF	0.027	MJS	0
ISE	1.0e-14	FC	0.5
NE	2.17	TF	8.7e-12
BR	1	XTF	18
NR	1.05	VTF	19.1
VAR	Infinity	ITF	0.082
IKR	Infinity	PTF	0
ISC	0	TR	0.635e-9
NC	2	EG	1.11
RE	0.6	XTB	0
RB	17.9	XTI	3
RBM	1.02	KF	0
IRB	4.01e-4	AF	1
RC	10.5		
CJE	0.358e-12		
VJE	0.71		
MJE	0.5		
CJC	0.162e-12		
VJC	0.79		

(1) Gummel-Poon Model

## UNITS

Parameter	Units
time	seconds
capacitance	farads
inductance	henries
resistance	ohms
voltage	volts
current	amps

## ADDITIONAL PARAMETERS

Parameters	68033
CCB	0.08e-12
CCE	0.08e-12
LB	0.65e-9
LE	0.95e-9
CCBPKG	0.1e-12
CCEPKG	0.1e-12
CBEPKG	0.01e-12
LBX	0.3e-9
LCX	0.5e-9
LEX	0.3e-9

## MODEL RANGE

Frequency: 0.05 to 3.0 GHz

Bias:  $V_{CE} = 2.5 \text{ V to } 6 \text{ V}$ ,  $I_C = 0.3 \text{ mA to } 20 \text{ mA}$ 

Date: 7/97

## Note:

This nonlinear model utilized the latest data available. See our Design Parameter Library at [www.cel.com](http://www.cel.com) for this data.

SCHMATIC

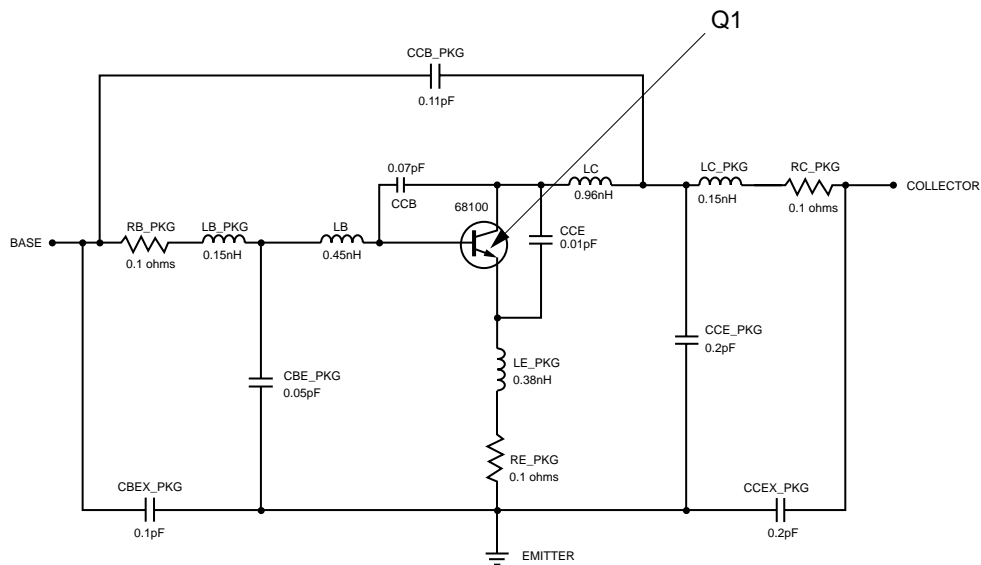

BJT NONLINEAR MODEL PARAMETERS (1)

Parameters	Q1	Parameters	Q1
IS	3.84e-16	MJC	0.64
BF	124.9	XCJC	0
NF	1.05	CJS	0
VAF	11.9	VJS	0.75
IKF	0.027	MJS	0
ISE	1.0e-14	FC	0.5
NE	2.17	TF	8.7e-12
BR	1	XTF	18
NR	1.05	VTF	19.1
VAR	Infinity	ITF	0.082
IKR	Infinity	PTF	0
ISC	0	TR	0.635e-9
NC	2	EG	1.11
RE	0.6	XTB	0
RB	17.9	XTI	3
RBM	1.02	KF	0
IRB	4.01e-4	AF	1
RC	10.5		
CJE	0.358e-12		
VJE	0.71		
MJE	0.5		
CJC	0.162e-12		
VJC	0.79		

UNITS

Parameter	Units
time	seconds
capacitance	farads
inductance	henries
resistance	ohms
voltage	volts
current	amps

MODEL RANGE

Frequency: 0.05 to 5.0 GHz  
 Bias: VCE = 6 V, IC = 5 mA to 20 mA  
 Date: 10/31/96

(1) Gummel-Poon Model



**OUTLINE DIMENSIONS** (Units in mm)

**NE68000 (CHIP)**  
(Chip Thickness: 160 μm)

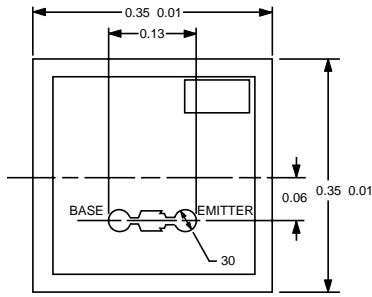

**PACKAGE OUTLINE 35**  
(MICRO-X)

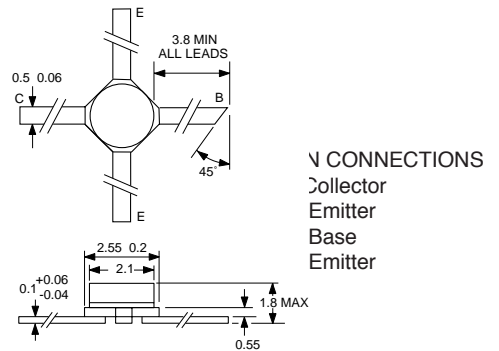

**4 CONNECTIONS**  
Collector  
Emitter  
Base  
Emitter

**PACKAGE OUTLINE 18**

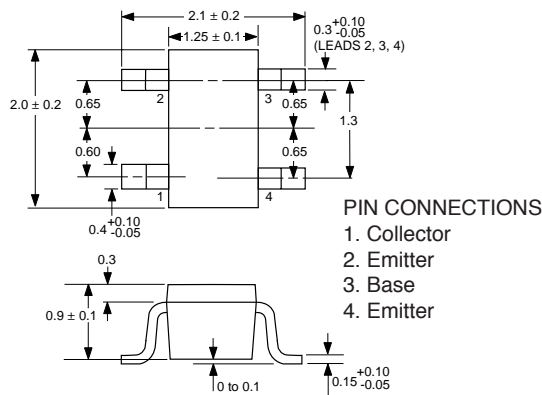

**PIN CONNECTIONS**  
1. Collector  
2. Emitter  
3. Base  
4. Emitter

**PACKAGE OUTLINE 18**  
**RECOMMENDED P.C.B. LAYOUT**

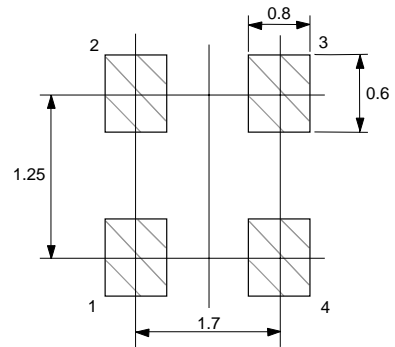

**PACKAGE OUTLINE 19**

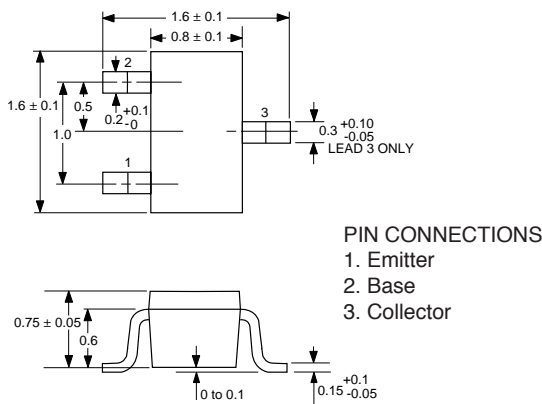

**PIN CONNECTIONS**  
1. Emitter  
2. Base  
3. Collector

**PACKAGE OUTLINE 19**  
**RECOMMENDED P.C.B. LAYOUT**

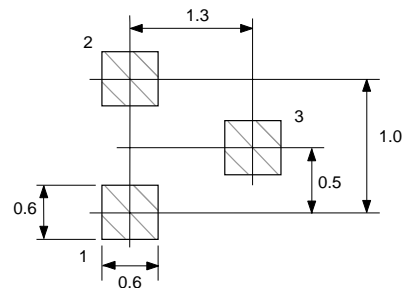

**PACKAGE OUTLINE 30**

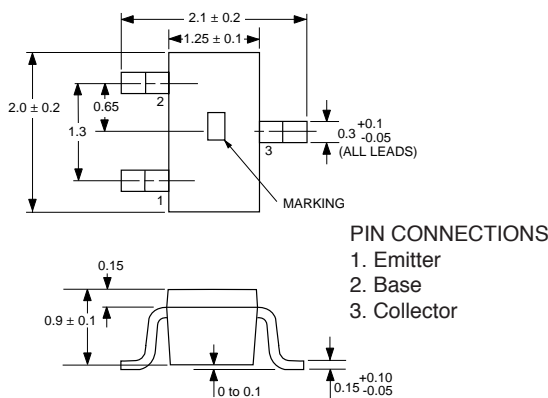

**PIN CONNECTIONS**  
1. Emitter  
2. Base  
3. Collector

**PACKAGE OUTLINE 30**  
**RECOMMENDED P.C.B. LAYOUT**

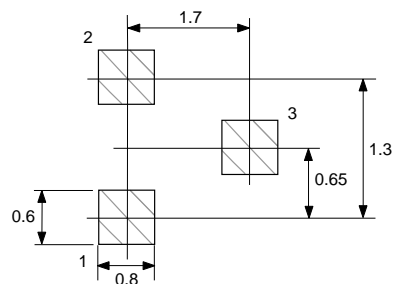

OUTLINE DIMENSIONS (Units in mm)

PACKAGE OUTLINE 33  
(SOT-23)

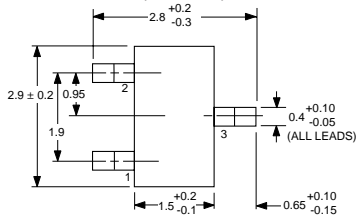

PIN CONNECTIONS

- 1. Emitter
- 2. Base
- 3. Collector

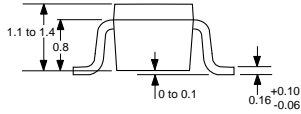

PACKAGE OUTLINE 33  
RECOMMENDED P.C.B. LAYOUT

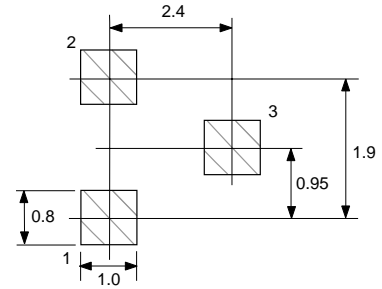

PACKAGE OUTLINE 39

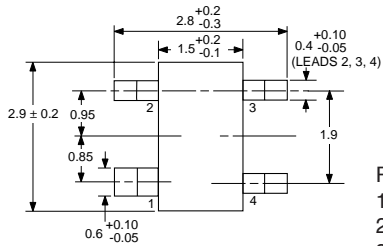

PIN CONNECTIONS

- 1. Collector
- 2. Emitter
- 3. Base
- 4. Emitter

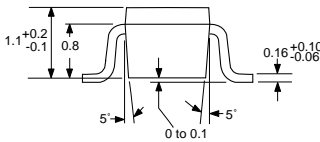

PACKAGE OUTLINE 39  
RECOMMENDED P.C.B. LAYOUT

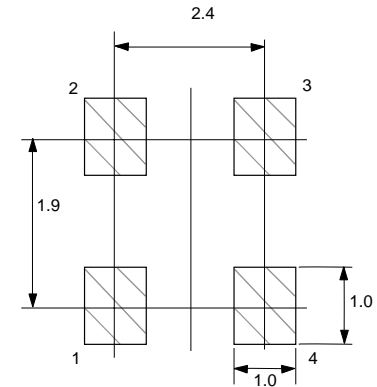

PACKAGE OUTLINE 39R

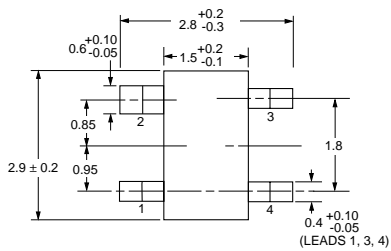

PIN CONNECTIONS

- 1. Emitter
- 2. Collector
- 3. Emitter
- 4. Base

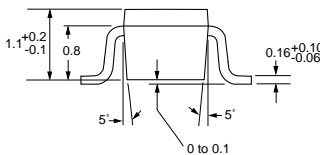

PACKAGE OUTLINE 39  
RECOMMENDED P.C.B. LAYOUT

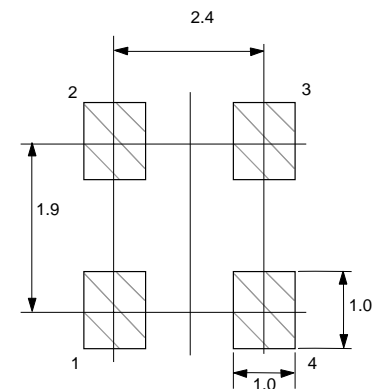

## ORDERING INFORMATION

PART NUMBER	QUANTITY	PACKAGING
NE68800	100	Waffle Pack
NE68018-T1-A <sup>1</sup>	3000	Tape & Reel
NE68019-T1-A <sup>1</sup>	3000	Tape & Reel
NE68030-T1-A <sup>1</sup>	3000	Tape & Reel
NE68033-T1B-A <sup>1</sup>	3000	Tape & Reel
NE68035	1	ESD Bag
NE68039-T1-A <sup>1</sup>	3000	Tape & Reel
NE68039R-T1	3000	Tape & Reel

Note:

- Lead material: Cu  
Lead plating: SnBi – 2.5%Bi Typ.

### Life Support Applications

These NEC products are not intended for use in life support devices, appliances, or systems where the malfunction of these products can reasonably be expected to result in personal injury. The customers of CEL using or selling these products for use in such applications do so at their own risk and agree to fully indemnify CEL for all damages resulting from such improper use or sale.

**CEL** California Eastern Laboratories, Your source for NEC RF, Microwave, Optoelectronic, and Fiber Optic Semiconductor Devices.  
4590 Patrick Henry Drive • Santa Clara, CA 95054-1817 • (408) 919-2500 • FAX (408) 988-0279 • [www.cel.com](http://www.cel.com)

DATA SUBJECT TO CHANGE WITHOUT NOTICE

Updated: 9-13-06

**Subject: Compliance with EU Directives**

CEL certifies, to its knowledge, that semiconductor and laser products detailed below are compliant with the requirements of European Union (EU) Directive 2002/95/EC Restriction on Use of Hazardous Substances in electrical and electronic equipment (RoHS) and the requirements of EU Directive 2003/11/EC Restriction on Penta and Octa BDE.

CEL Pb-free products have the same base part number with a suffix added. The suffix -A indicates that the device is Pb-free. The -AZ suffix is used to designate devices containing Pb which are exempted from the requirement of RoHS directive (\*). In all cases the devices have Pb-free terminals. All devices with these suffixes meet the requirements of the RoHS directive.

This status is based on CEL's understanding of the EU Directives and knowledge of the materials that go into its products as of the date of disclosure of this information.

Restricted Substance per RoHS	Concentration Limit per RoHS (values are not yet fixed)	Concentration contained in CEL devices	
		-A	-AZ
Lead (Pb)	< 1000 PPM	Not Detected	(*)
Mercury	< 1000 PPM	Not Detected	
Cadmium	< 100 PPM	Not Detected	
Hexavalent Chromium	< 1000 PPM	Not Detected	
PBB	< 1000 PPM	Not Detected	
PBDE	< 1000 PPM	Not Detected	

**If you should have any additional questions regarding our devices and compliance to environmental standards, please do not hesitate to contact your local representative.**

**Important Information and Disclaimer:** Information provided by CEL on its website or in other communications concerning the substance content of its products represents knowledge and belief as of the date that it is provided. CEL bases its knowledge and belief on information provided by third parties and makes no representation or warranty as to the accuracy of such information. Efforts are underway to better integrate information from third parties. CEL has taken and continues to take reasonable steps to provide representative and accurate information but may not have conducted destructive testing or chemical analysis on incoming materials and chemicals. CEL and CEL suppliers consider certain information to be proprietary, and thus CAS numbers and other limited information may not be available for release.

In no event shall CEL's liability arising out of such information exceed the total purchase price of the CEL part(s) at issue sold by CEL to customer on an annual basis.

See CEL Terms and Conditions for additional clarification of warranties and liability.