

# LM148JAN

## Quad 741 Op Amps

### General Description

The LM148 is a true quad LM741. It consists of four independent, high gain, internally compensated, low power operational amplifiers which have been designed to provide functional characteristics identical to those of the familiar LM741 operational amplifier. In addition the total supply current for all four amplifiers is comparable to the supply current of a single LM741 type op amp. Other features include input offset currents and input bias current which are much less than those of a standard LM741. Also, excellent isolation between amplifiers has been achieved by independently biasing each amplifier and using layout techniques which minimize thermal coupling.

The LM148 can be used anywhere multiple LM741 or LM1558 type amplifiers are being used and in applications where amplifier matching or high packing density is required.

### Features

- 741 op amp operating characteristics
- Class AB output stage—no crossover distortion
- Pin compatible with the LM124
- Overload protection for inputs and outputs
- Low supply current drain: 0.6 mA/Amplifier
- Low input offset voltage: 1 mV
- Low input offset current: 4 nA
- Low input bias current: 30 nA
- High degree of isolation between amplifiers: 120 dB
- Gain bandwidth product (unity gain): 1.0 MHz

### Ordering Information

NS PART NUMBER	SMD PART NUMBER	NS PACKAGE NUMBER	PACKAGE DESCRIPTION
JL148BCA	JM38510/11001BCA	J14A	14LD CERDIP
JL148BDA	JM38510/11001BDA	W14B	14LD CERPACK
JL148BZA	JM38510/11001BZA	WG14A	14LD Ceramic SOIC
JL148SCA	JM38510/11001SCA	J14A	14LD CERDIP
JL148SDA	JM38510/11001SDA	W14B	14LD CERPACK

### Connection Diagram

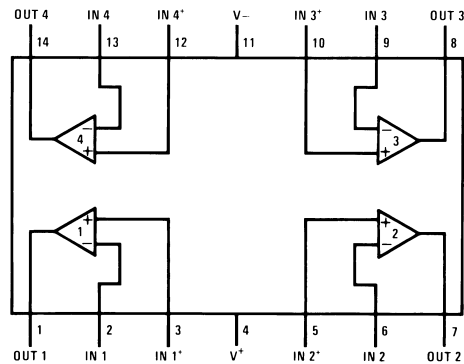

20122702

**Top View**

See NS Package Number J14A, W14B, WG14A

## Schematic Diagram

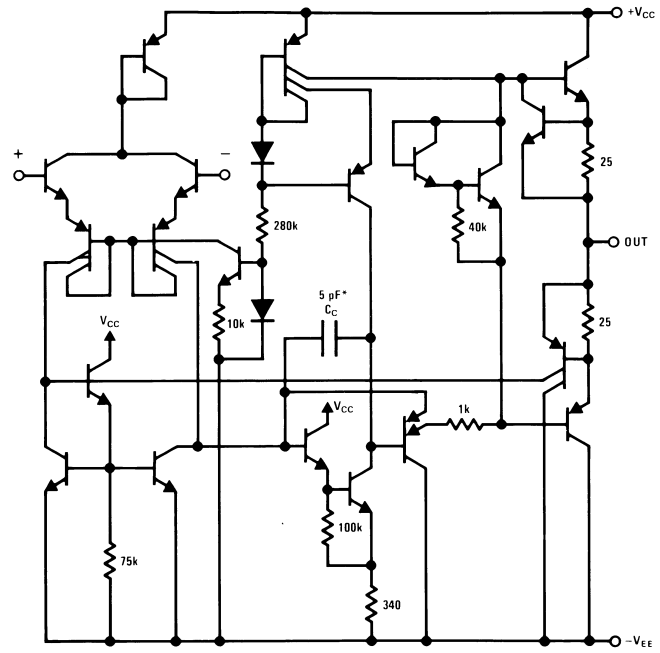

20122701

\* 1 pF in the LM149

**Absolute Maximum Ratings** (Note 1)

Supply Voltage	±22V
Input Voltage Range	±20V
Input Current Range	-0.1mA to 10mA
Differential Input Voltage (Note 2)	±30V
Output Short Circuit Duration (Note 3)	Continuous
Power Dissipation ( $P_d$ at 25°C) (Note 4)	
CERDIP	400mW
CERPACK	350mW
Thermal Resistance	
$\theta_{JA}$	
CERDIP (Still Air)	103°C/W
CERDIP (500LF/ Min Air flow)	52°C/W
CERPACK (Still Air)	140°C/W
CERPACK (500LF/ Min Air flow)	100°C/W
Ceramic SOIC (Still Air)	176°C/W
Ceramic SOIC (500LF/ Min Air flow)	116°C/W
$\theta_{JC}$	
CERDIP	19°C/W
CERPACK	25°C/W
Ceramic SOIC	25°C/W
Package Weight (typical)	
CERDIP	TBD
CERPACK	465mg
Ceramic SOIC	415mg
Maximum Junction Temperature ( $T_{JMAX}$ )	175°C
Operating Temperature Range	-55°C ≤ $T_A$ ≤ +125°C
Storage Temperature Range	-65°C ≤ $T_A$ ≤ +150°C
Lead Temperature (Soldering, 10 sec.) Ceramic	300°C
ESD tolerance (Note 5)	500V

**Quality Conformance Inspection**

MIL-STD-883, Method 5005 — Group A

Subgroup	Description	Temp ( °C)
1	Static tests at	+25
2	Static tests at	+125
3	Static tests at	-55
4	Dynamic tests at	+25
5	Dynamic tests at	+125
6	Dynamic tests at	-55
7	Functional tests at	+25
8A	Functional tests at	+125
8B	Functional tests at	-55
9	Switching tests at	+25
10	Switching tests at	+125
11	Switching tests at	-55

## Electrical Characteristics

DC PARAMETERS (The following conditions apply to all parameters, unless otherwise specified.)  $\pm V_{CC} = \pm 20V$ ,  $V_{CM} = 0V$ , measure each amplifier.

Symbol	Parameter	Conditions	Notes	Min	Max	Units	Sub-groups
$V_{IO}$	Input Offset Voltage	$+V_{CC} = 35V, -V_{CC} = -5V,$ $V_{CM} = -15V$		-5.0	+5.0	mV	1
				-6.0	+6.0	mV	2, 3
		$+V_{CC} = 5V, -V_{CC} = -35V,$ $V_{CM} = +15V$		-5.0	+5.0	mV	1
				-6.0	+6.0	mV	2, 3
		$+V_{CC} = 5V, -V_{CC} = -5V,$		-5.0	+5.0	mV	1
				-6.0	+6.0	mV	2, 3
Delta $V_{IO}$ / Delta $T$	Input Offset Voltage Temperature Stability	$25^{\circ}C \leq T_A \leq 125^{\circ}C$	(Note 6)	-25	25	$\mu V/^{\circ}C$	2
		$-55^{\circ}C \leq T_A \leq 25^{\circ}C$	(Note 6)	-25	25	$\mu V/^{\circ}C$	3
$I_{IO}$	Input Offset Current	$+V_{CC} = 35V, -V_{CC} = -5V,$ $V_{CM} = -15V$		-25	+25	nA	1, 2
				-75	+75	nA	3
		$+V_{CC} = 5V, -V_{CC} = -35V,$ $V_{CM} = +15V$		-25	+25	nA	1, 2
				-75	+75	nA	3
		$+V_{CC} = 5V, -V_{CC} = -5V,$		-25	+25	nA	1, 2
				-75	+75	nA	3
Delta $I_{IO}$ / Delta $T$	Input Offset Current Temperature Stability	$25^{\circ}C \leq T_A \leq 125^{\circ}C$	(Note 6)	-200	200	$pA/^{\circ}C$	2
		$-55^{\circ}C \leq T_A \leq 25^{\circ}C$	(Note 6)	-400	400	$pA/^{\circ}C$	3
$\pm I_{IB}$	Input Bias Current	$+V_{CC} = 35V, -V_{CC} = -5V,$ $V_{CM} = -15V$		-0.1	100	nA	1, 2
				-0.1	325	nA	3
		$+V_{CC} = 5V, -V_{CC} = -35V,$ $V_{CM} = +15V$		-0.1	100	nA	1, 2
				-0.1	325	nA	3
		$+V_{CC} = 5V, -V_{CC} = -5V,$		-0.1	100	nA	1, 2
				-0.1	325	nA	3
PSRR+	Power Supply Rejection Ratio	$-V_{CC} = -20V, +V_{CC} = 20V$ to 10V	(Note 7)	-100	100	$\mu V/V$	1, 2, 3
PSRR-	Power Supply Rejection Ratio	$+V_{CC} = 20V, -V_{CC} = -20V$ to -10V	(Note 7)	-100	100	$\mu V/V$	1, 2, 3
CMRR	Common Mode Rejection Ratio	$V_{CM} = \pm 15V, \pm 5V \leq V_{CC} \leq \pm 35V$		76		dB	1, 2, 3

## Electrical Characteristics

AC / DC PARAMETERS (The following conditions apply to all parameters, unless otherwise specified.)  
 $\pm V_{CC} = \pm 20V$ ,  $V_{CM} = 0V$ , measure each amplifier.

Symbol	Parameter	Conditions	Notes	Min	Max	Units	Sub-groups
$+ I_{OS}$	Short Circuit Current	$+V_{CC} = 15V, -V_{CC} = -15V,$ $V_{CM} = -10V$		-55		mA	1, 2
				-75		mA	3
$- I_{OS}$	Short Circuit Current	$+V_{CC} = 15V, -V_{CC} = -15V,$ $V_{CM} = +10V$			55	mA	1, 2
					75	mA	3
$I_{CC}$	Power Supply Current	$+V_{CC} = 15V, -V_{CC} = -15V$			3.6	mA	1
					4.5	mA	2, 3
$-A_{VS}$	Open Loop Voltage Gain	$V_{OUT} = -15V, R_L = 10K\Omega$		50		V/mV	4
				25		V/mV	5, 6
		$V_{OUT} = -15V, R_L = 2K\Omega$		50		V/mV	4
				25		V/mV	5, 6

**Electrical Characteristics** (Continued)

AC / DC PARAMETERS (The following conditions apply to all parameters, unless otherwise specified.)

 $\pm V_{CC} = \pm 20V$ ,  $V_{CM} = 0V$ , measure each amplifier.

Symbol	Parameter	Conditions	Notes	Min	Max	Units	Sub-groups
$+A_{VS}$	Open Loop Voltage Gain	$V_{OUT} = +15V$ , $R_L = 10K\Omega$		50		V/mV	4
				25		V/mV	5, 6
		$V_{OUT} = +15V$ , $R_L = 2K\Omega$		50		V/mV	4
				25		V/mV	5, 6
$A_{VS}$	Open Loop Voltage Gain	$V_{CC} = \pm 5V$ , $V_{OUT} = \pm 2V$ , $R_L = 10K\Omega$		10		V/mV	4, 5, 6
		$V_{CC} = \pm 5V$ , $V_{OUT} = \pm 2V$ , $R_L = 2K\Omega$		10		V/mV	4, 5, 6
$+V_{OP}$	Output Voltage Swing	$R_L = 10K\Omega$		+16		V	4, 5, 6
		$R_L = 2K\Omega$		+15		V	4, 5, 6
$-V_{OP}$	Output Voltage Swing	$R_L = 10K\Omega$			-16	V	4, 5, 6
		$R_L = 2K\Omega$			-15	V	4, 5, 6
$TR_{TR}$	Transient Response Time	$V_{IN} = 50mV$ , $A_V = 1$			1	$\mu S$	7, 8A, 8B
$TR_{OS}$	Transient Response Time	$V_{IN} = 50mV$ , $A_V = 1$			25	%	7, 8A, 8B
$\pm SR$	Slew Rate	$V_{IN} = -5V$ to $+5V$ , $A_V = 1$		0.2		V/ $\mu S$	7, 8A, 8B
		$V_{IN} = +5V$ to $-5V$ , $A_V = 1$		0.2		V/ $\mu S$	7, 8A, 8B

**Electrical Characteristics**AC PARAMETERS (The following conditions apply to all parameters, unless otherwise specified.)  $\pm V_{CC} = \pm 20V$ ,  $V_{CM} = 0V$ , measure each amplifier.

Symbol	Parameter	Conditions	Notes	Min	Max	Units	Sub-groups
$NI_{BB}$	Noise (Broadband)	$BW = 10Hz$ to $5KHz$			15	$\mu V_{RMS}$	7
$NI_{PC}$	Noise (Popcorn)	$R_S = 20K\Omega$			40	$\mu V_{PK}$	7
$C_S$	Channel Separation	$V_{IN} = \pm 10V$ , A to B, $R_L = 2K\Omega$		80		dB	7
		$V_{IN} = \pm 10V$ , A to C, $R_L = 2K\Omega$		80		dB	7
		$V_{IN} = \pm 10V$ , A to D, $R_L = 2K\Omega$		80		dB	7
		$V_{IN} = \pm 10V$ , B to A, $R_L = 2K\Omega$		80		dB	7
		$V_{IN} = \pm 10V$ , B to C, $R_L = 2K\Omega$		80		dB	7
		$V_{IN} = \pm 10V$ , B to D, $R_L = 2K\Omega$		80		dB	7
		$V_{IN} = \pm 10V$ , C to A, $R_L = 2K\Omega$		80		dB	7
		$V_{IN} = \pm 10V$ , C to B, $R_L = 2K\Omega$		80		dB	7
		$V_{IN} = \pm 10V$ , C to D, $R_L = 2K\Omega$		80		dB	7
		$V_{IN} = \pm 10V$ , D to A, $R_L = 2K\Omega$		80		dB	7
		$V_{IN} = \pm 10V$ , D to B, $R_L = 2K\Omega$		80		dB	7
		$V_{IN} = \pm 10V$ , D to C, $R_L = 2K\Omega$		80		dB	7

**Electrical Characteristics**DC DRIFT PARAMETERS (The following conditions apply to all parameters, unless otherwise specified.)  $\pm V_{CC} = \pm 20V$ ,  $V_{CM} = 0V$ , measure each amplifier. Delta calculations performed on JAN S and QMLV devices at group B, subgroup 5 only.

Symbol	Parameter	Conditions	Notes	Min	Max	Units	Sub-groups
$V_{IO}$	Input Offset Voltage			-1	1	mV	1
$\pm I_{IB}$	Input Bias Current			-15	15	nA	1

## Electrical Characteristics (Continued)

**Note 1:** Absolute Maximum Ratings indicate limits beyond which damage to the device may occur. Operating Ratings indicate conditions for which the device is functional, but do not guarantee specific performance limits. For guaranteed specifications and test conditions, see the Electrical Characteristics. The guaranteed specifications apply only for the test conditions listed. Some performance characteristics may degrade when the device is not operated under the listed test conditions.

**Note 2:** The differential input voltage range shall not exceed the supply voltage range.

**Note 3:** Any of the amplifier outputs can be shorted to ground indefinitely; however, more than one should not be simultaneously shorted as the maximum junction temperature will be exceeded.

**Note 4:** The maximum power dissipation for these devices must be derated at elevated temperatures and is indicated by  $T_{JMAX}$ ,  $\theta_{JA}$ , and the ambient temperature,  $T_A$ . The maximum available power dissipation at any temperature is  $P_d = (T_{JMAX} - T_A)/\theta_{JA}$  or the number given in the Absolute Maximum Ratings, whichever is less.

**Note 5:** Human body model, 1.5 k $\Omega$  in series with 100 pF.

**Note 6:** Calculated parameter.

**Note 7:** Datalogs as  $\mu V$

## Cross Talk Test Circuit $V_S = \pm 15V$

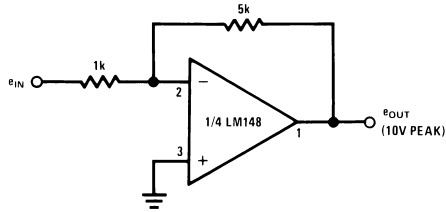

20122706

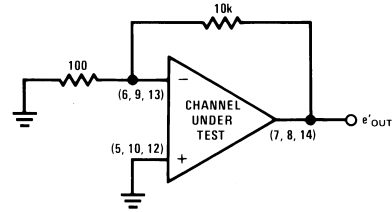

20122707

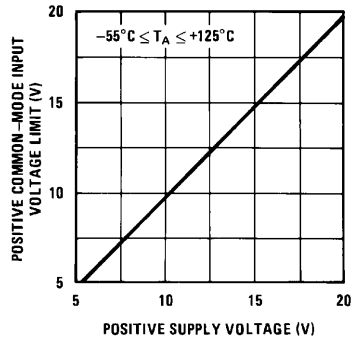

20122743

# Typical Performance Characteristics

Supply Current

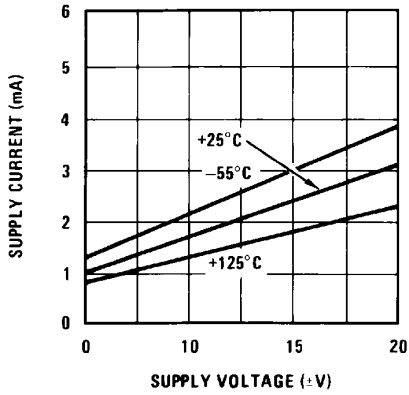

20122723

Input Bias Current

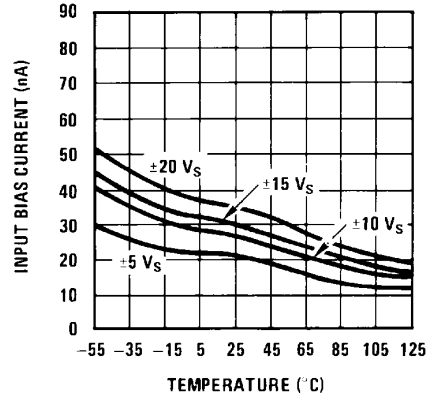

20122724

Voltage Swing

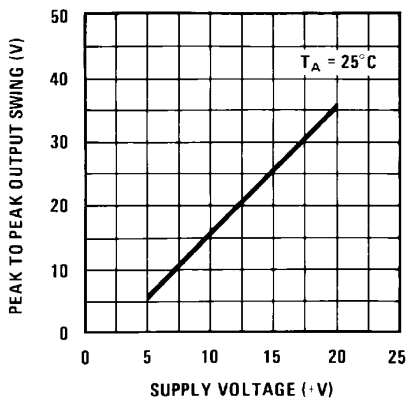

20122725

Positive Current Limit

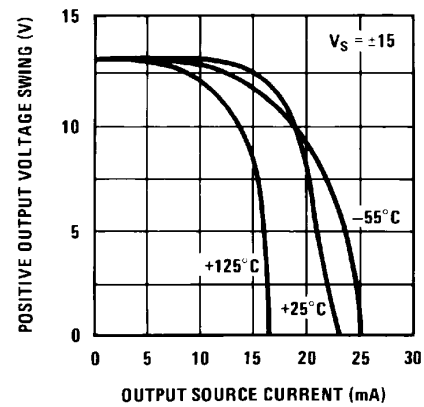

20122726

Negative Current Limit

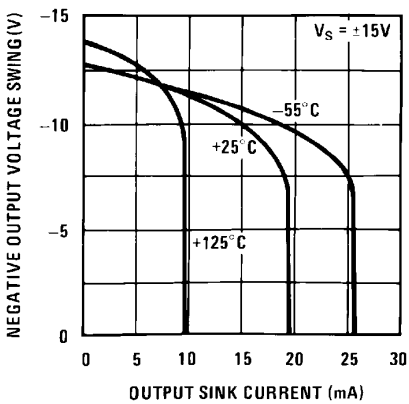

20122727

Output Impedance

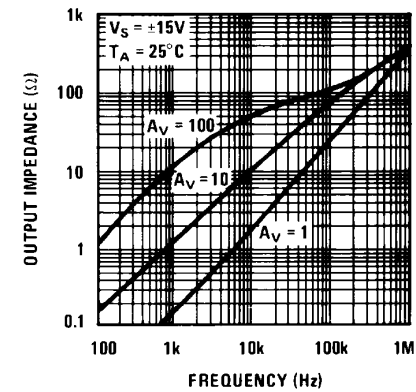

20122728

# Typical Performance Characteristics (Continued)

**Common-Mode Rejection Ratio**

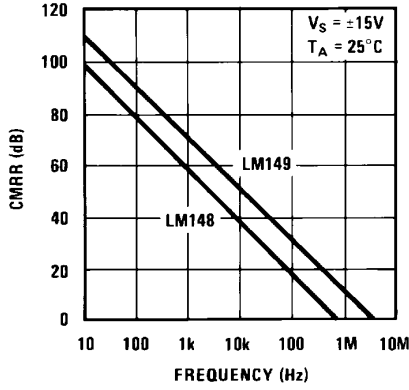

20122729

**Open Loop Frequency Response**

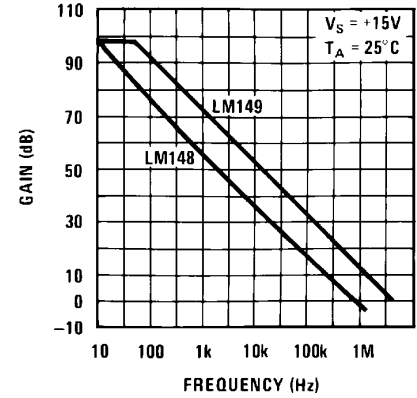

20122730

**Bode Plot LM148**

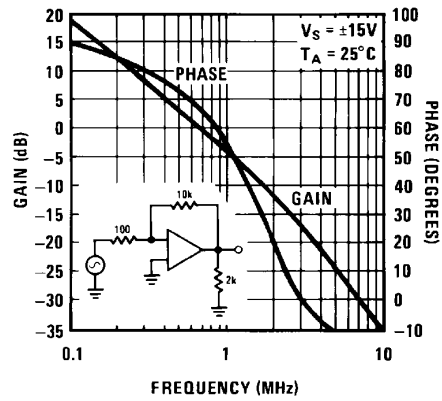

20122731

**Large Signal Pulse Response (LM148)**

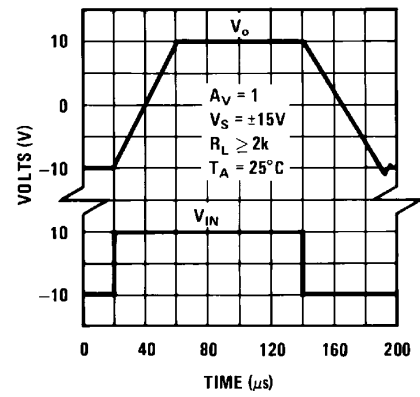

20122733

**Small Signal Pulse Response (LM148)**

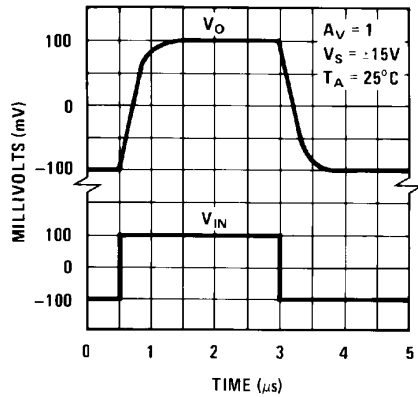

20122735

**Undistorted Output Voltage Swing**

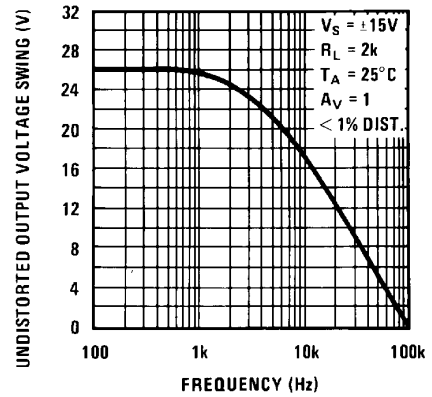

20122737



Typical Performance Characteristics (Continued)

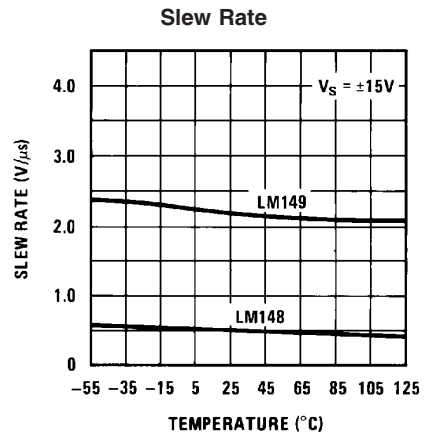
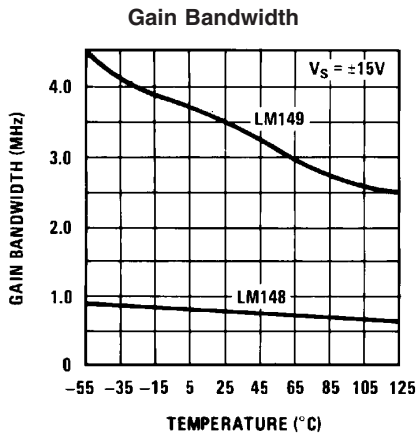

Inverting Large Signal Pulse Response (LM148)

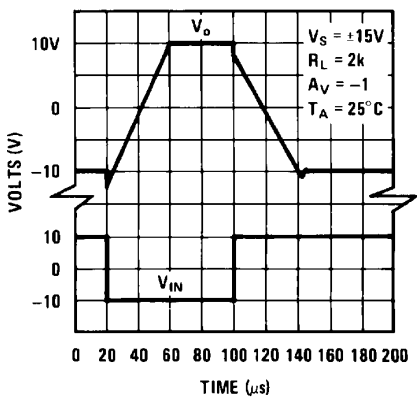

Input Noise Voltage and Noise Current

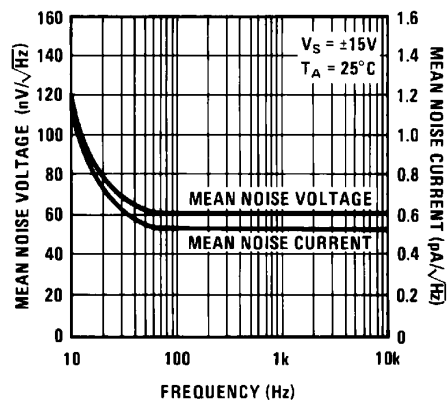

Positive Common-Mode Input Voltage Limit

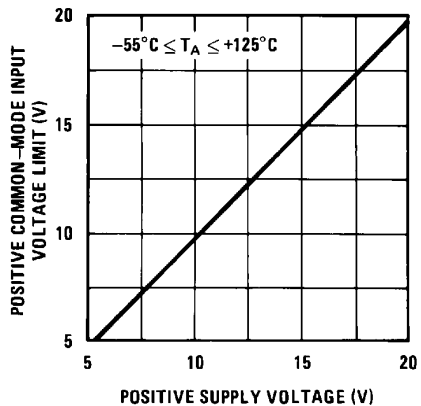

Negative Common-Mode Input Voltage Limit

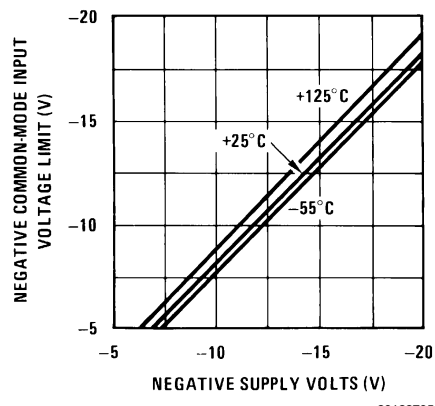

## Application Hints

The LM148 series are quad low power LM741 op amps. In the proliferation of quad op amps, these are the first to offer the convenience of familiar, easy to use operating characteristics of the LM741 op amp. In those applications where LM741 op amps have been employed, the LM148 series op amps can be employed directly with no change in circuit performance.

The package pin-outs are such that the inverting input of each amplifier is adjacent to its output. In addition, the amplifier outputs are located in the corners of the package which simplifies PC board layout and minimizes package related capacitive coupling between amplifiers.

The input characteristics of these amplifiers allow differential input voltages which can exceed the supply voltages. In addition, if either of the input voltages is within the operating common-mode range, the phase of the output remains correct. If the negative limit of the operating common-mode range is exceeded at both inputs, the output voltage will be positive. For input voltages which greatly exceed the maximum supply voltages, either differentially or common-mode, resistors should be placed in series with the inputs to limit the current.

Like the LM741, these amplifiers can easily drive a 100 pF capacitive load throughout the entire dynamic output voltage and current range. However, if very large capacitive loads must be driven by a non-inverting unity gain amplifier, a resistor should be placed between the output (and feedback

connection) and the capacitance to reduce the phase shift resulting from the capacitive loading.

The output current of each amplifier in the package is limited. Short circuits from an output to either ground or the power supplies will not destroy the unit. However, if multiple output shorts occur simultaneously, the time duration should be short to prevent the unit from being destroyed as a result of excessive power dissipation in the IC chip.

As with most amplifiers, care should be taken lead dress, component placement and supply decoupling in order to ensure stability. For example, resistors from the output to an input should be placed with the body close to the input to minimize "pickup" and maximize the frequency of the feedback pole which capacitance from the input to ground creates.

A feedback pole is created when the feedback around any amplifier is resistive. The parallel resistance and capacitance from the input of the device (usually the inverting input) to AC ground set the frequency of the pole. In many instances the frequency of this pole is much greater than the expected 3 dB frequency of the closed loop gain and consequently there is negligible effect on stability margin. However, if the feedback pole is less than approximately six times the expected 3 dB frequency a lead capacitor should be placed from the output to the input of the op amp. The value of the added capacitor should be such that the RC time constant of this capacitor and the resistance it parallels is greater than or equal to the original feedback pole time constant.

## Typical Applications—LM148

### One Decade Low Distortion Sinewave Generator

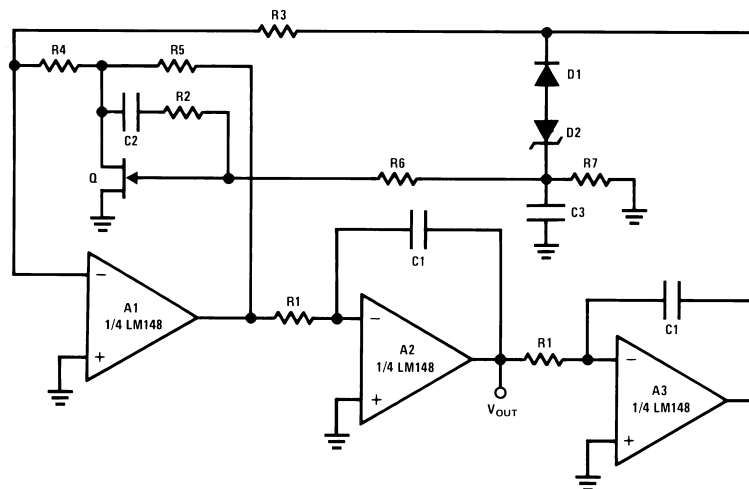

20122708

$$f = \frac{1}{2\pi R_1 C_1} \times \sqrt{K}, K = \frac{R_4 R_5}{R_3} \left( \frac{1}{r_{DS}} + \frac{1}{R_4} + \frac{1}{R_5} \right), r_{DS} \approx \frac{R_{ON}}{\left( 1 - \frac{V_{GS}}{V_P} \right)^{1/2}}$$

$f_{MAX} = 5 \text{ kHz}$ ,  $THD \leq 0.03\%$

$R_1 = 100\text{k pot}$ ,  $C_1 = 0.0047 \mu\text{F}$ ,  $C_2 = 0.01 \mu\text{F}$ ,  $C_3 = 0.1 \mu\text{F}$ ,  $R_2 = R_6 = R_7 = 1\text{M}$ ,

$R_3 = 5.1\text{k}$ ,  $R_4 = 12\Omega$ ,  $R_5 = 240\Omega$ ,  $Q = \text{NS5102}$ ,  $D_1 = 1\text{N914}$ ,  $D_2 = 3.6\text{V avalanche}$

diode (ex. LM103),  $V_S = \pm 15\text{V}$

A simpler version with some distortion degradation at high frequencies can be made by using A1 as a simple inverting amplifier, and by putting back to back zeners in the feedback loop of A3.

## Typical Applications—LM148 (Continued)

### Low Cost Instrumentation Amplifier

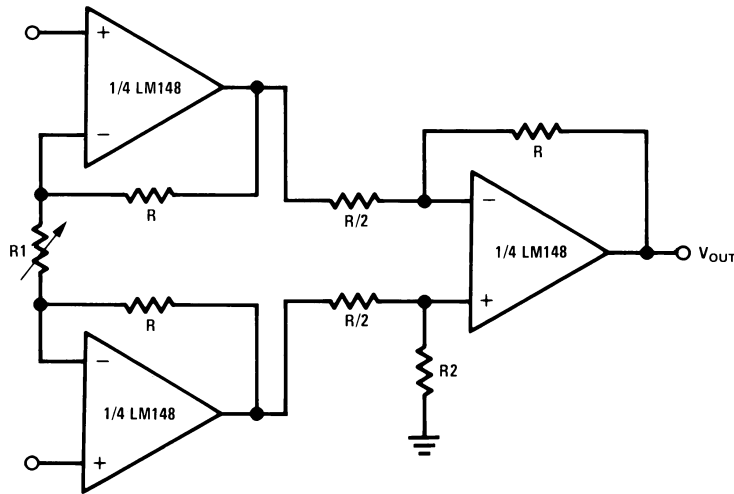

20122709

$$V_{OUT} = 2 \left( \frac{2R}{R1} + 1 \right) \cdot V_S - 3V \leq V_{IN\,CM} \leq V_S^+ - 3V,$$

$V_S = \pm 15V$

$R = R2$ , trim  $R2$  to boost CMRR

### Low Drift Peak Detector with Bias Current Compensation

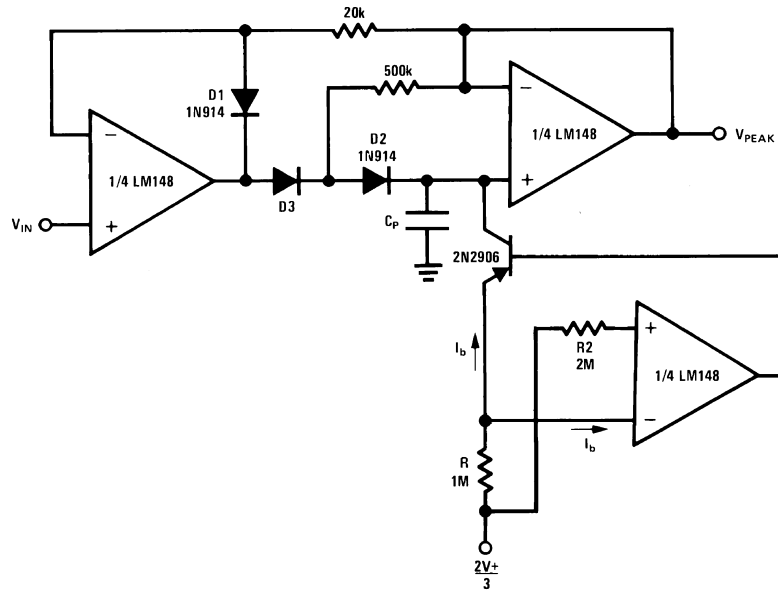

20122710

Adjust  $R$  for minimum drift

$D3$  low leakage diode

$D1$  added to improve speed

$V_S = \pm 15V$

# Typical Applications—LM148 (Continued)

## Universal State-Variable Filter

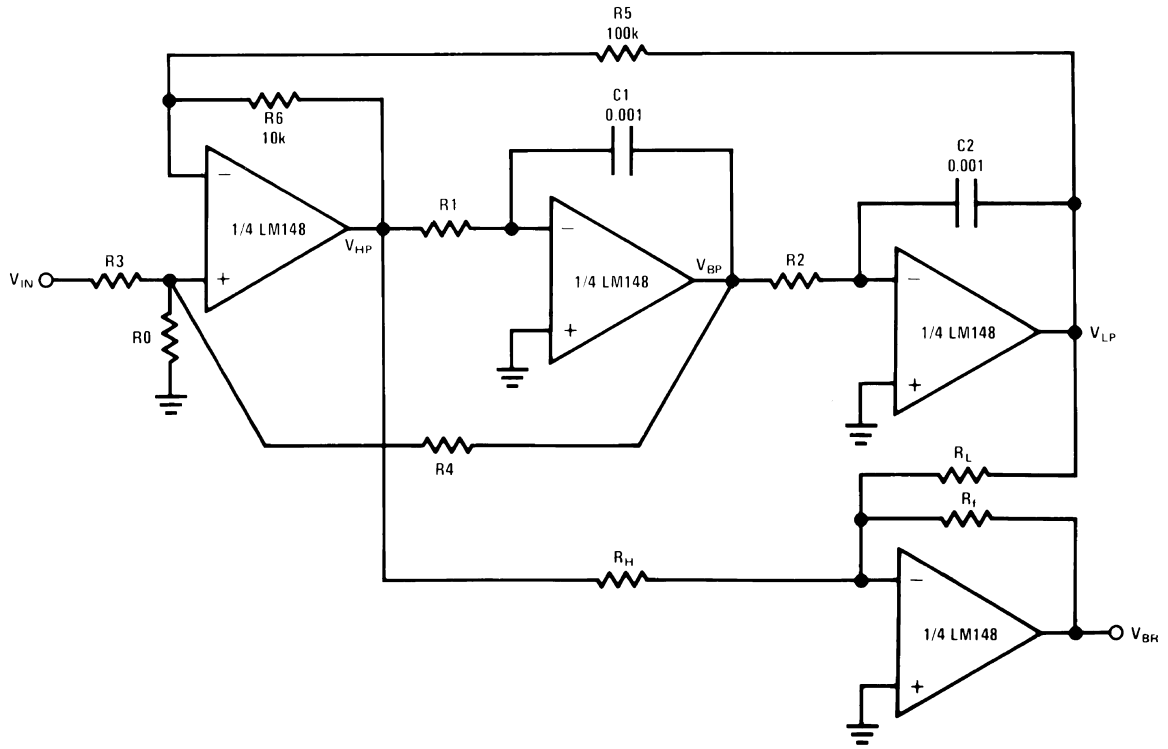

20122711

Tune Q through R0,

For predictable results:  $f_0 Q \leq 4 \times 10^4$

Use Band Pass output to tune for Q

$$\frac{V(s)}{V_{IN}(s)} = \frac{N(s)}{D(s)}, \quad D(s) = s^2 + \frac{s\omega_0}{Q} + \omega_0^2$$

$$N_{HP}(s) = s^2 H_{OHP}, \quad N_{BP}(s) = \frac{-s\omega_0 H_{OBP}}{Q}, \quad N_{LP} = \omega_0^2 H_{OLP}$$

$$f_0 = \frac{1}{2\pi} \sqrt{\frac{R_6}{R_5}} \sqrt{\frac{1}{t_1 t_2}}, \quad t_i = R_i C_i, \quad Q = \left( \frac{1 + R_4/R_3 + R_4/R_0}{1 + R_6/R_5} \right) \left( \frac{R_6 t_1}{R_5 t_2} \right)^{1/2}$$

$$f_{NOTCH} = \frac{1}{2\pi} \left( \frac{R_H}{R_L t_1 t_2} \right)^{1/2}, \quad H_{OHP} = \frac{1 + R_6/R_5}{1 + R_3/R_0 + R_3/R_4}, \quad H_{OBP} = \frac{1 + R_4/R_3 + R_4/R_0}{1 + R_3/R_0 + R_3/R_4}$$

$$H_{OLP} = \frac{1 + R_5/R_6}{1 + R_3/R_0 + R_3/R_4}$$

# Typical Applications—LM148 (Continued)

## A 1 kHz 4 Pole Butterworth

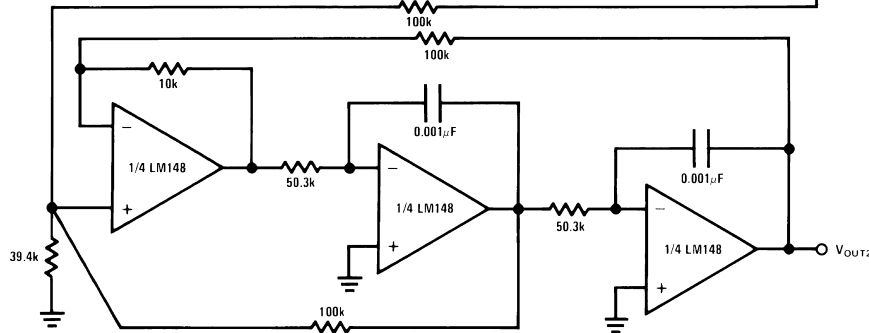
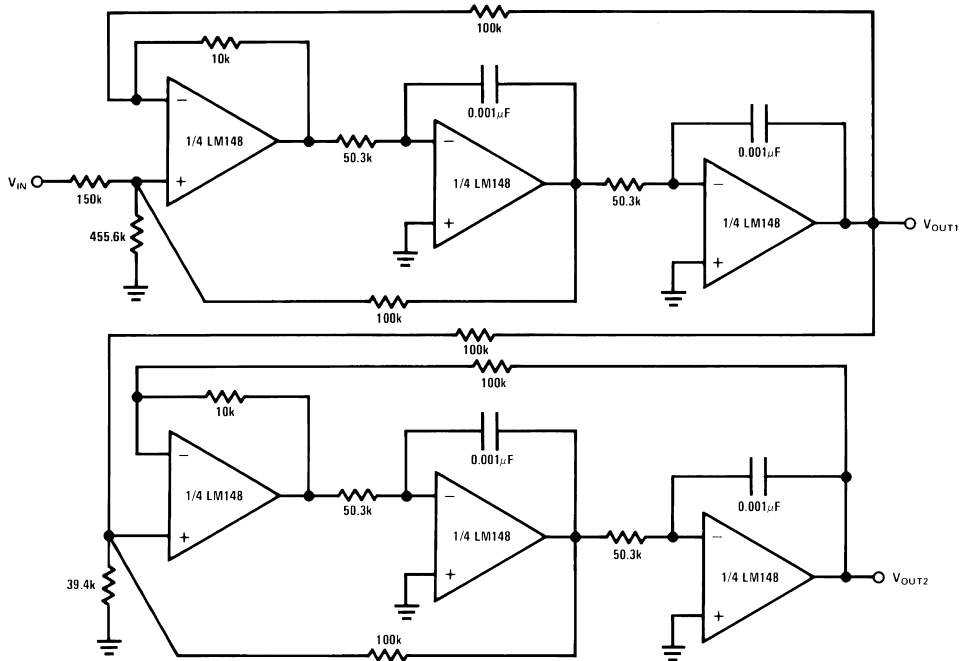

20122712

Use general equations, and tune each section separately

$Q_{1stSECTION} = 0.541$ ,  $Q_{2ndSECTION} = 1.306$

The response should have 0 dB peaking

## A 3 Amplifier Bi-Quad Notch Filter

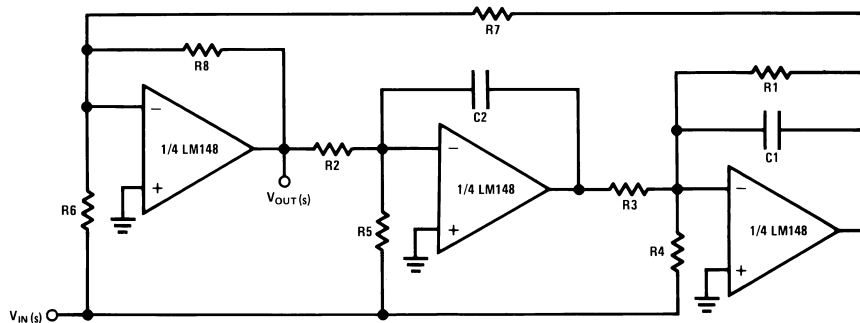

20122713

$$Q = \sqrt{\frac{R8}{R7}} \times \frac{R1C1}{\sqrt{R3C2R2C1}}, \quad f_o = \frac{1}{2\pi} \sqrt{\frac{R8}{R7}} \times \frac{1}{\sqrt{R2R3C1C2}}, \quad f_{NOTCH} = \frac{1}{2\pi} \sqrt{\frac{R6}{R3R5R7C1C2}}$$

$$\text{Necessary condition for notch: } \frac{1}{R6} = \frac{R1}{R4R7}$$

Ex:  $f_{NOTCH} = 3 \text{ kHz}$ ,  $Q = 5$ ,  $R1 = 270k$ ,  $R2 = R3 = 20k$ ,  $R4 = 27k$ ,  $R5 = 20k$ ,  $R6 = R8 = 10k$ ,  $R7 = 100k$ ,  $C1 = C2 = 0.001 \mu\text{F}$

Better noise performance than the state-space approach.

# Typical Applications—LM148 (Continued)

## A 4th Order 1 kHz Elliptic Filter (4 Poles, 4 Zeros)

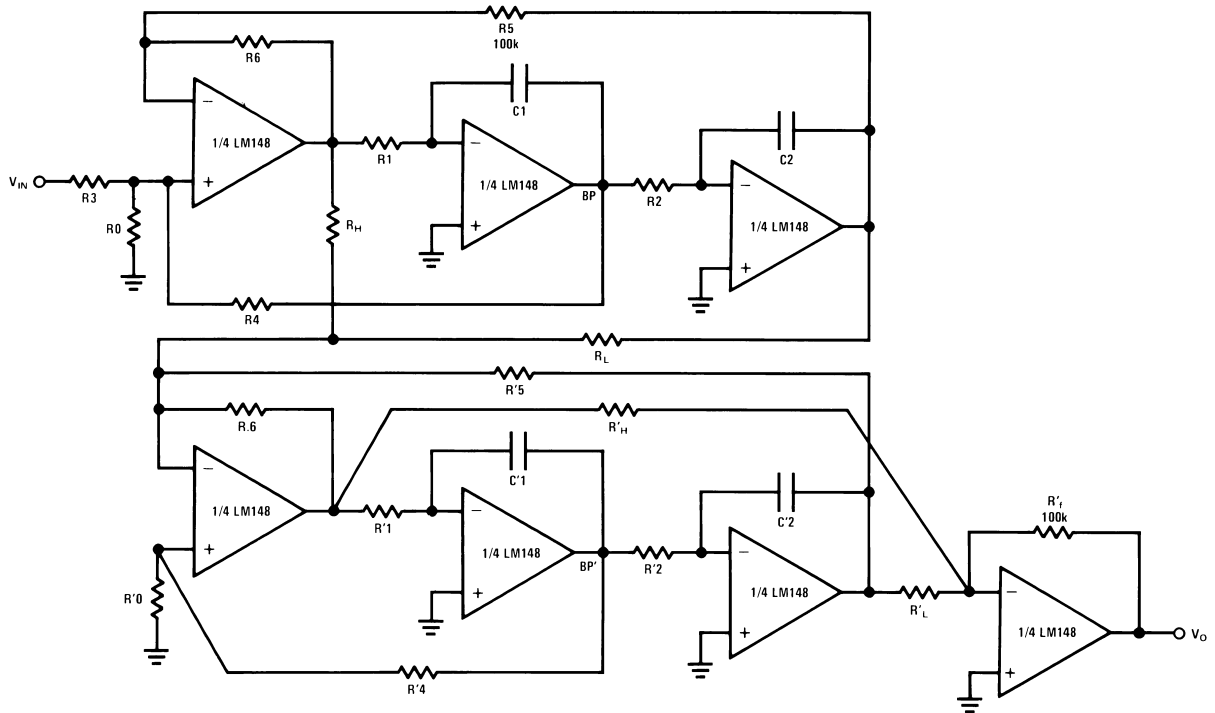

20122714

$$R1C1 = R2C2 = t$$

$$R'1C'1 = R'2C'2 = t'$$

$f_C = 1 \text{ kHz}$ ,  $f_S = 2 \text{ kHz}$ ,  $f_p = 0.543$ ,  $f_z = 2.14$ ,  $Q = 0.841$ ,  $f'_p = 0.987$ ,  $f'_z = 4.92$ ,  $Q' = 4.403$ , normalized to ripple BW

$$f = \frac{1}{2\pi R1C1} \times \sqrt{K}, K = \frac{R4R5}{R3} \left( \frac{1}{r_{DS}} + \frac{1}{R4} + \frac{1}{R5} \right), r_{DS} \approx \frac{R_{ON}}{\left( 1 - \frac{V_{GS}}{V_P} \right)^{1/2}}$$

Use the BP outputs to tune Q, Q', tune the 2 sections separately

$R1 = R2 = 92.6k$ ,  $R3 = R4 = R5 = 100k$ ,  $R6 = 10k$ ,  $R0 = 107.8k$ ,  $R_L = 100k$ ,  $R_H = 155.1k$ ,

$R'1 = R'2 = 50.9k$ ,  $R'4 = R'5 = 100k$ ,  $R'6 = 10k$ ,  $R'0 = 5.78k$ ,  $R'_L = 100k$ ,  $R'_H = 248.12k$ ,  $R'_f = 100k$ . All capacitors are 0.001  $\mu F$ .

Lowpass Response

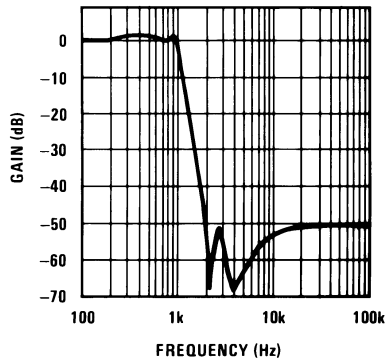

20122715

# Typical Simulation

LM148, LM741 Macromodel for Computer Simulation

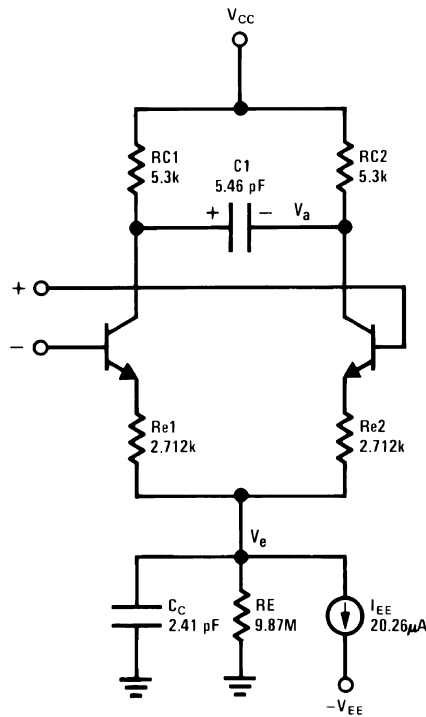

20122721

For more details, see IEEE Journal of Solid-State Circuits, Vol. SC-9, No. 6, December 1974

**Note 8:**  $\omega_1 = 112I_S = 8 \times 10^{-16}$

**Note 9:**  $\omega_2 = 144^*C2 = 6 \text{ pF}$  for LM149

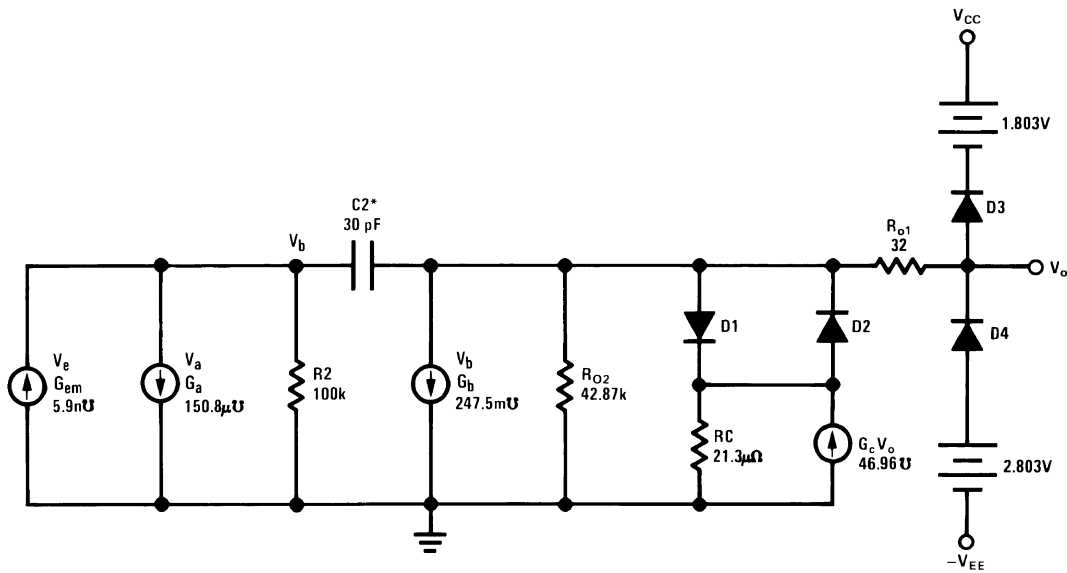

20122722

## Revision History Section

Date Released	Revision	Section	Originator	Changes
02/15/05	A	New Release, Corporate format	L. Lytle	1 MDS data sheet converted into one Corp. data sheet format. MJLM148-X, Rev. 0C1. MDS data sheet will be archived.



**Physical Dimensions** inches (millimeters)

unless otherwise noted

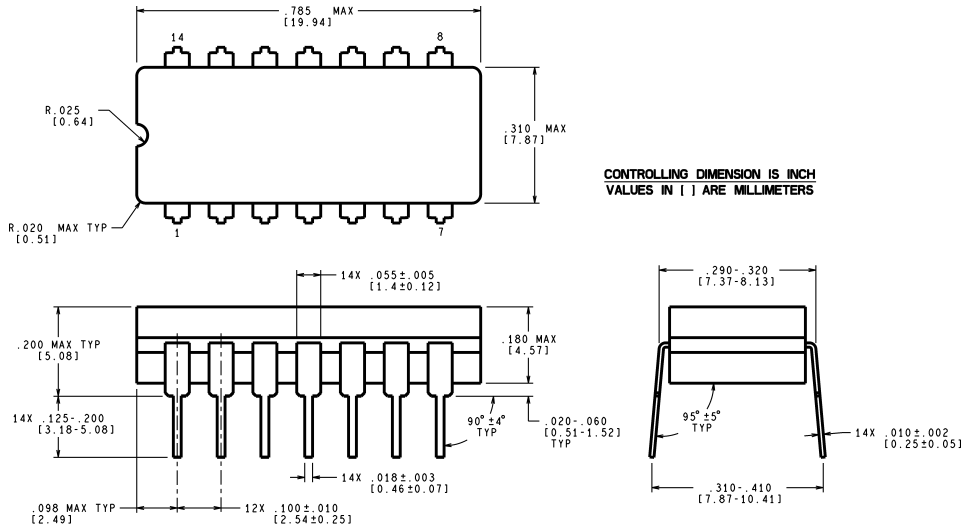

CONTROLLING DIMENSION IS INCH  
VALUES IN [ ] ARE MILLIMETERS

J14A (Rev J)

**Ceramic Dual-In-Line Package (J)  
NS Package Number J14A**

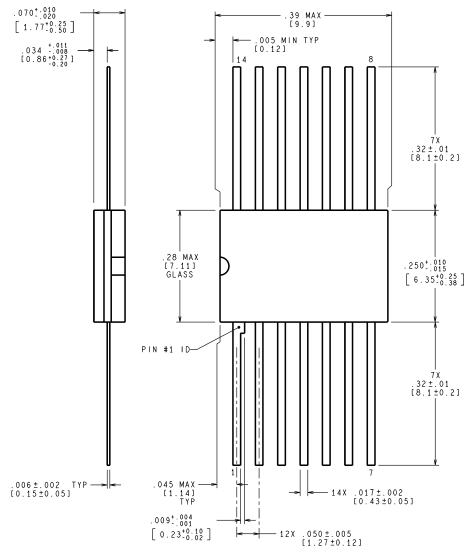

CONTROLLING DIMENSION IS INCH  
VALUES IN [ ] ARE MILLIMETERS

W14B (Rev P)

**Ceramic Flatpack (W)  
NS Package Number W14B**

**Physical Dimensions** inches (millimeters) unless otherwise noted (Continued)

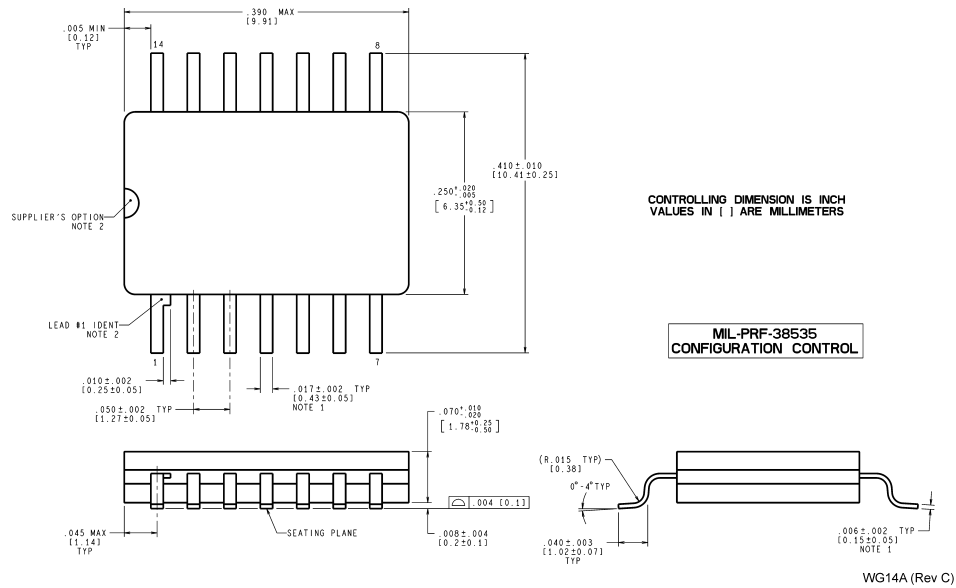

**Ceramic SOIC (WG)  
NS Package Number WG14A**

National does not assume any responsibility for use of any circuitry described, no circuit patent licenses are implied and National reserves the right at any time without notice to change said circuitry and specifications.

For the most current product information visit us at [www.national.com](http://www.national.com).

**LIFE SUPPORT POLICY**

NATIONAL'S PRODUCTS ARE NOT AUTHORIZED FOR USE AS CRITICAL COMPONENTS IN LIFE SUPPORT DEVICES OR SYSTEMS WITHOUT THE EXPRESS WRITTEN APPROVAL OF THE PRESIDENT AND GENERAL COUNSEL OF NATIONAL SEMICONDUCTOR CORPORATION. As used herein:

1. Life support devices or systems are devices or systems which, (a) are intended for surgical implant into the body, or (b) support or sustain life, and whose failure to perform when properly used in accordance with instructions for use provided in the labeling, can be reasonably expected to result in a significant injury to the user.
2. A critical component is any component of a life support device or system whose failure to perform can be reasonably expected to cause the failure of the life support device or system, or to affect its safety or effectiveness.

**BANNED SUBSTANCE COMPLIANCE**

National Semiconductor manufactures products and uses packing materials that meet the provisions of the Customer Products Stewardship Specification (CSP-9-111C2) and the Banned Substances and Materials of Interest Specification (CSP-9-111S2) and contain no "Banned Substances" as defined in CSP-9-111S2.

 **National Semiconductor**  
Americas Customer  
Support Center  
Email: [new.feedback@nsc.com](mailto:new.feedback@nsc.com)  
Tel: 1-800-272-9959

**National Semiconductor**  
Europe Customer Support Center  
Fax: +49 (0) 180-530 85 86  
Email: [europa.support@nsc.com](mailto:europa.support@nsc.com)  
Deutsch Tel: +49 (0) 69 9508 6208  
English Tel: +44 (0) 870 24 0 2171  
Français Tel: +33 (0) 1 41 91 8790

**National Semiconductor**  
Asia Pacific Customer  
Support Center  
Email: [ap.support@nsc.com](mailto:ap.support@nsc.com)

**National Semiconductor**  
Japan Customer Support Center  
Fax: 81-3-5639-7507  
Email: [jpn.feedback@nsc.com](mailto:jpn.feedback@nsc.com)  
Tel: 81-3-5639-7560

[www.national.com](http://www.national.com)