

5V Voltage Controlled Crystal Oscillators

- ♦ **Applications:** Phase-Locked Loops (PLL's); Clock Recovery; Reference Signal Tracking; Synthesizers; Frequency Modulation/Demodulation
- ♦ 8-pin Half DIL Package
- ♦ 1.0 to 52.0 MHz Frequency Range
- ♦ 0.5V to 4.5V Control Voltage
- ♦ ±25ppm Stability
- ♦ -40°C to 85°C Operating Temperature

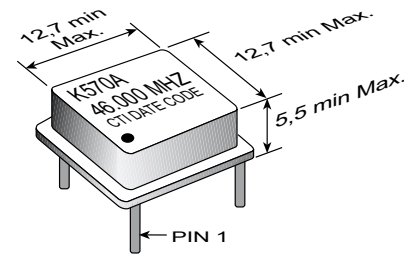

ELECTRICAL SPECIFICATIONS

Model	K570A	
Frequency Range (MHz)	1 to 52	
Input Current (mA)	< 26	
Frequency Control Function	(For Custom Deviation Range, Vc Range, etc. - Consult Factory)	
Deviation (ppm)		
Minimum	±100	
Maximum	±150	
Linearity (%)	< 10	
Modulation Bandwidth (±3dB)	> 20KHz	
Nominal Control Voltage (V)	2.5	
Control Voltage Range (V)	0.5 to 4.5	
Transfer Function	Positive	
Input Impedance	> 50KΩ @ 10KHz	
Frequency Stability (ppm)		
Overall	Inclusive of Calibration, Temperature, Voltage, Load and Aging	
0°C to +70°C	±25	
-40°C to +85°C	±50	
Temperature Range (°C)		
Operating	-40°C to +85°C	
Storage	-55°C to +125°C	
Supply Voltage (V)	+5.0V ±5%	
Symmetry (%) CMOS/TTL	40/60	
Start Up Time (ms)	<10	
Typical SSB Phase Noise (dBC/Hz)	10Hz	-65
Offset from Carrier	100Hz	-95
	1KHz	-120
	10KHz	-140
	100KHz	-150

PART NUMBERING GUIDE

K570A XX - Specify Frequency

- "Blank" = 0°C to 70°C Operating Temp.
- "M" = -40°C to +85°C Operating Temp.
- "A" = ±25ppm (0°C to 70°C Op. Temp. Only)
- "B" = ±50ppm

5V Voltage Controlled Crystal Oscillators

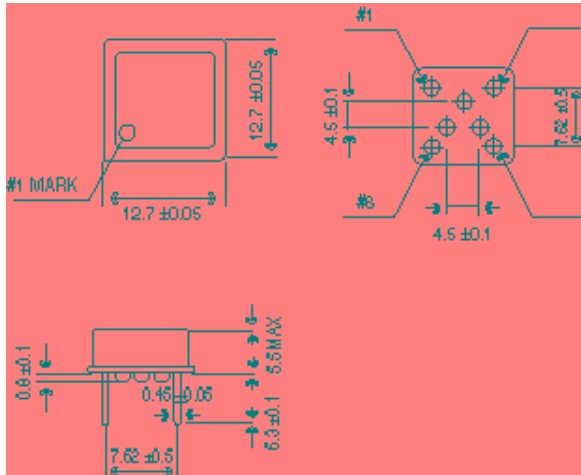

PIN	FUNCTION
1	Voltage Control
4	Gnd/ & Case Gnd
5	Output
8	+ V _{CC}

SHIPPING TUBE CROSS SECTION

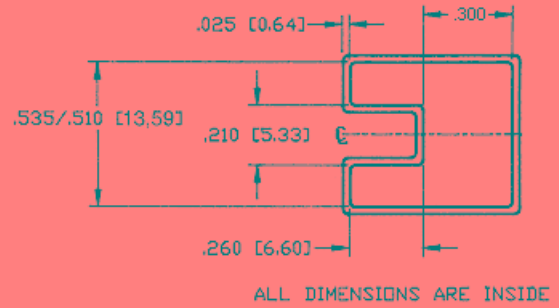

OUTPUT WAVEFORM

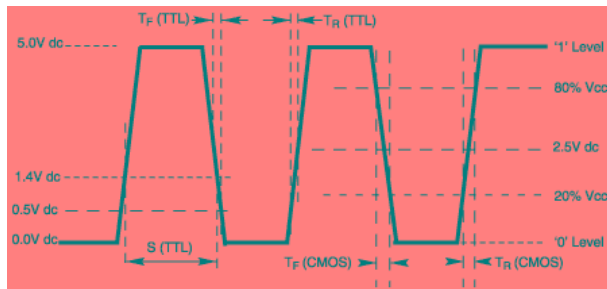

TEST CIRCUIT DIAGRAM

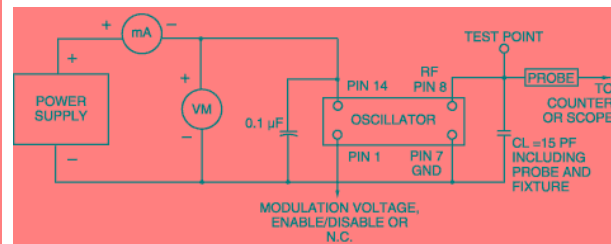

MECHANICAL AND ENVIRONMENTAL SPECIFICATIONS

TEST METHODS	REFERENCE PROCEDURES	DESCRIPTION
Temperature Cycle	MIL-STD-833, Mtd 1010, Cond. B	-55°C to +125°C; Air-to-Air; 100 cycles; 10 min. dwell
Mechanical Shock	MIL-STD-883, Mtd 2002, Cond. B	1500 g's
Vibration	MIL-STD 883, Mtd 2007, Cond. B	20-2000 Hz; 0.06 inch; 15g's; 3 planes
Humidity Steady State	MIL-STD-202, Mtd 103	40°C; 90%-95% R.H.; 56 days
Thermal Shock	MIL-STD-883, Mtd 1011.7 Cond. B	100°C to 0°C; Water-to-Water; 15 cycles
Electrostatic Discharge	MIL-STD-883, Mtd 3015 Class II	2 KV to 4 KV Threshold
Solderability	MIL-STD-883, Mtd 2022.2	Solder dip; Meniscograph Criteria
Hermeticity	MIL-STD-883, Mtd 1014.8, Cond. A1	Mass spectro. 2 x 10 ⁻⁸ atmos. CC/sec He
Resistance to Soldering	MIL-STD-202, Mtd 210D, Cond. C	260°C; 10 seconds: 1 inch/sec.
Lead Integrity	MIL-STD-883, Mtd 2004.5, Cond. A, B1	Lead tension & bend stress
Marking Permanence	MIL-STD-883, Mtd 2015.8	Resistance to solvents
Life Test	MIL-STD-883, Mtd 1005.6	125°C, powered, 1000 hours minimum