

PLEASE CHECK WWW.MOLEX.COM FOR LATEST PART INFORMATION

Part Number: [0555600607](#)
Status: **Active**
Overview: [slimstack_050mm_020_pitch](#)
Description: 0.50mm (.020") Pitch SlimStack™ Plug, Surface Mount, Dual Row, Vertical, 1.50mm (.059") Stack Height, 60 Circuits

Documents:

3D Model	Product Specification PS-54722-010 (PDF)
Drawing (PDF)	RoHS Certificate of Compliance (PDF)
Product Specification PS-54722-009 (PDF)	

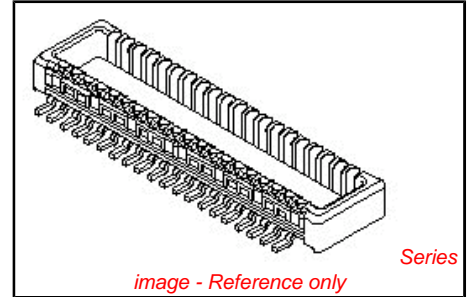

General

Product Family	PCB Headers
Series	55560
Application	Board-to-Board
Overview	slimstack_050mm_020_pitch
Product Name	SlimStack™

Physical

Breakaway	No
Circuits (Loaded)	60
Circuits (maximum)	60
First Mate / Last Break	No
Glow-Wire Compliant	No
Guide to Mating Part	No
Keying to Mating Part	None
Lock to Mating Part	Yes
Mated Height (in)	0.059 In
Mated Height (mm)	1.50 mm
Material - Metal	Brass
Material - Plating Mating	Gold
Material - Plating Termination	Gold
Number of Rows	2
Orientation	Vertical
PC Tail Length (in)	0.029 In
PC Tail Length (mm)	0.74 mm
PCB Locator	No
PCB Retention	None
Packaging Type	Embossed Tape on Reel
Pitch - Mating Interface (in)	0.020 In
Pitch - Mating Interface (mm)	0.50 mm
Plating min: Mating (µin)	10
Plating min: Mating (µm)	0.25
Plating min: Termination (µin)	4
Plating min: Termination (µm)	0.1
Shrouded	Fully
Stackable	No
Temperature Range - Operating	-25°C to +85°C
Termination Interface: Style	Surface Mount

Electrical

Current - Maximum per Contact	0.5A
Voltage - Maximum	50V

Material Info

Reference - Drawing Numbers

<p>EU RoHS ELV and RoHS Compliant REACH SVHC Not Reviewed Halogen-Free Status Halogen-Free</p>	<p>China RoHS</p>
--	--------------------------

Need more information on product environmental compliance?

Email productcompliance@molex.com
 For a multiple part number RoHS Certificate of Compliance, [click here](#)

Please visit the [Contact Us](#) section for any non-product compliance questions.

Search Parts in this Series
[55560Series](#)

Mates With
[54722 PCB Receptacle](#)

Packaging Specification
Product Specification

Sales Drawing

SPK-55560-001
PS-54722-009, PS-54722-010, RPS-54722-024,
RPS-54722-025, RPS-54722-026, RPS-54722-029,
RPS-54722-030, RPS-54722-031, RPS-54722-034
SD-55560-007

This document was generated on 05/27/2010

PLEASE CHECK WWW.MOLEX.COM FOR LATEST PART INFORMATION

10 9 8 7 6 5 4 3 2 1

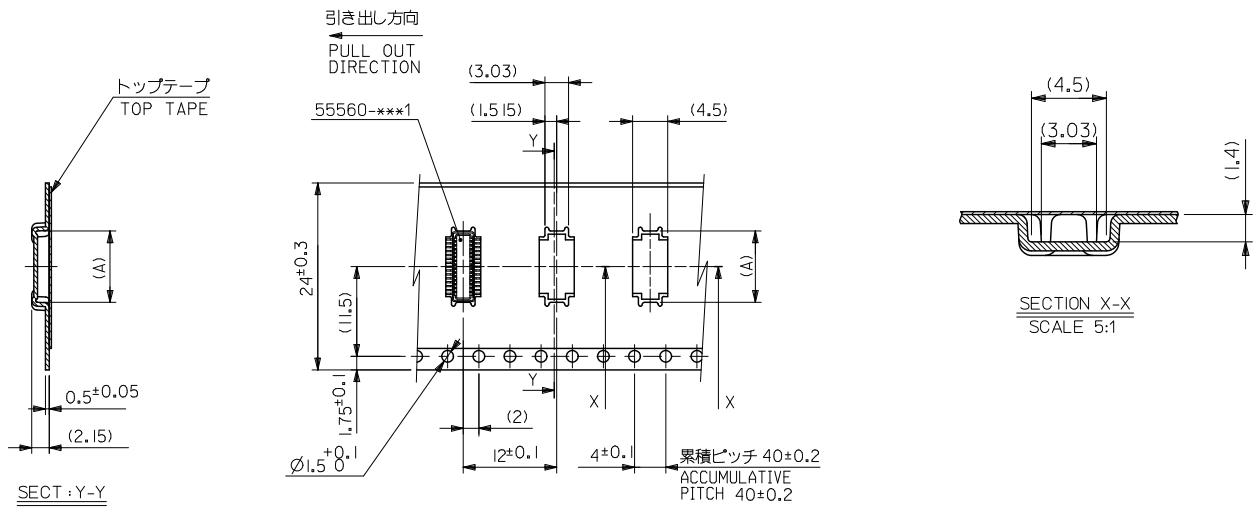

24mm幅キャリアテープ
24mm WIDTH CARRIER TAPE

24	25.5	14.15	55560-0507	55560-***7	50	
		11.65	55560-0407		40	
		10.15	55560-0347		34	
		9.15	55560-0307		30	
		7.65	55560-0247		24	
		7.15	55560-0227		22	
キャリアテープ幅 CARRIER TAPE WIDTH		B	(A)	MATERIAL No.	MODEL No.	極数 CIRCUIT

REVISED EC NO: J2010-1529 DRW: YON002 CHK: S.MARYAMA APPR: M.SASAO 2010/01/28 2010/02/01 2010/02/02	GENERAL TOLERANCES (UNLESS SPECIFIED)		DIMENSION STYLE MM ONLY		SCALE ---	DESIGN UNITS METRIC	THIRD ANGLE PROJECTION
	10 UNDER	±0.2	DRAWN BY S. AIHARA	DATE '00/10/06	TITLE 0.5 B-T0-B PLUG ASSY (HGT=1.5) EMBSTP PKG (SHEET 3 OF 5)		
	10 OVER 30 UNDER	±0.25	CHECKED BY M. SASAO	DATE '03/03/31	MOLEX INCORPORATED		
	30 OVER	±0.3	APPROVED BY M. SASAO	DATE '03/03/31	DOCUMENT NO. SD-55560-007	SHEET NO. 3 OF 5	
	ANGULAR ±3 °		MATERIAL NO. SEE TABLE		THIS DRAWING CONTAINS INFORMATION THAT IS PROPRIETARY TO MOLEX INCORPORATED AND SHOULD NOT BE USED WITHOUT WRITTEN PERMISSION		
DRAFT WHERE APPLICABLE MUST REMAIN WITHIN DIMENSIONS							

10 9 8 7 6 5 4 3 2 1

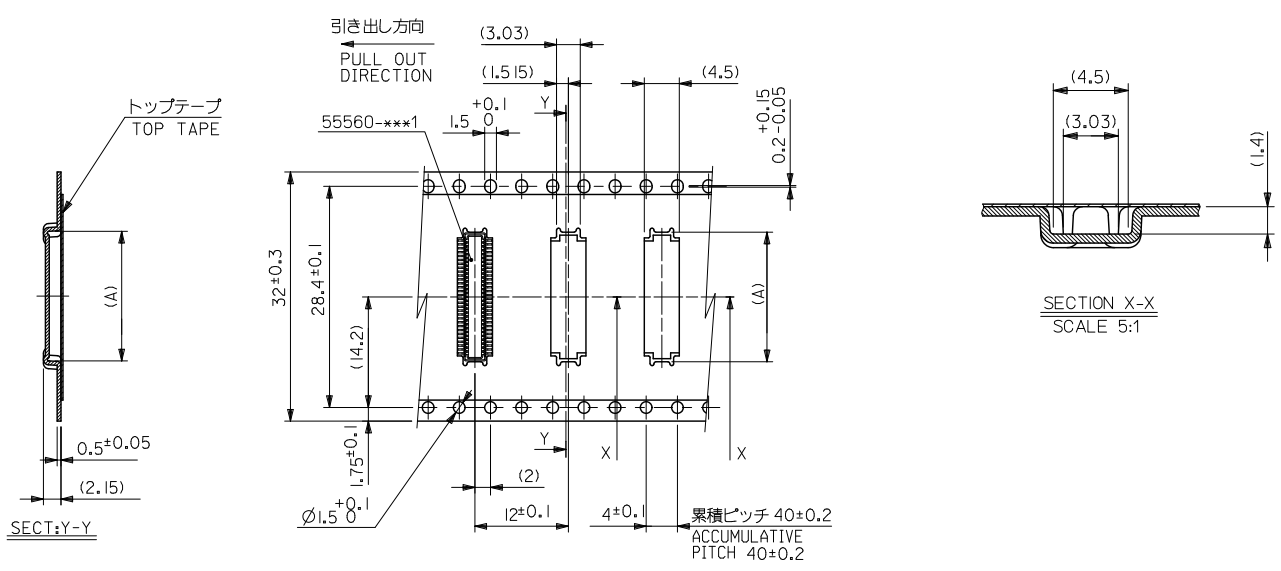

32mm幅キャリアテープ
32mm WIDTH CARRIER TAPE

32	33.5	16.65	55560-0607	55560-***7	60
キャリアテープ幅 CARRIER TAPE WIDTH	B	(A)	MATERIAL No.	MODEL No.	極数 CIRCUIT

REVISED EC NO: J2010-1529 DRW: YON002 CHK: S.MARUYAMA APPR: M.SASAO 2010/01/28 2010/02/01 2010/02/02	GENERAL TOLERANCES (UNLESS SPECIFIED)		DIMENSION STYLE MM ONLY		SCALE ---	DESIGN UNITS METRIC	THIRD ANGLE PROJECTION
	10 UNDER	±0.2	DRAWN BY T. YASUI	DATE '02/03/06	TITLE 0.5 B-T0-B PLUG ASSY (HGT=1.5) EMBSTP PKG (SHEET 4 OF 5)		
	10 OVER 30 UNDER	±0.25	CHECKED BY M. SASAO	DATE '03/03/31	MOLEX INCORPORATED		
	30 OVER	±0.3	APPROVED BY M. SASAO	DATE '03/03/31	DOCUMENT NO. SD-55560-007	SHEET NO. 4 OF 5	
ANGULAR ±3°		DRAFT WHERE APPLICABLE MUST REMAIN WITHIN DIMENSIONS		MATERIAL NO. SEE CHART		THIS DRAWING CONTAINS INFORMATION THAT IS PROPRIETARY TO MOLEX INCORPORATED AND SHOULD NOT BE USED WITHOUT WRITTEN PERMISSION	

10 9 8 7 6 5 4 3 2 1

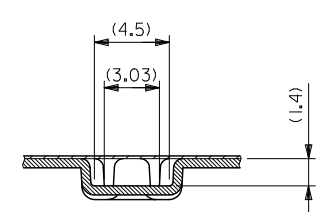
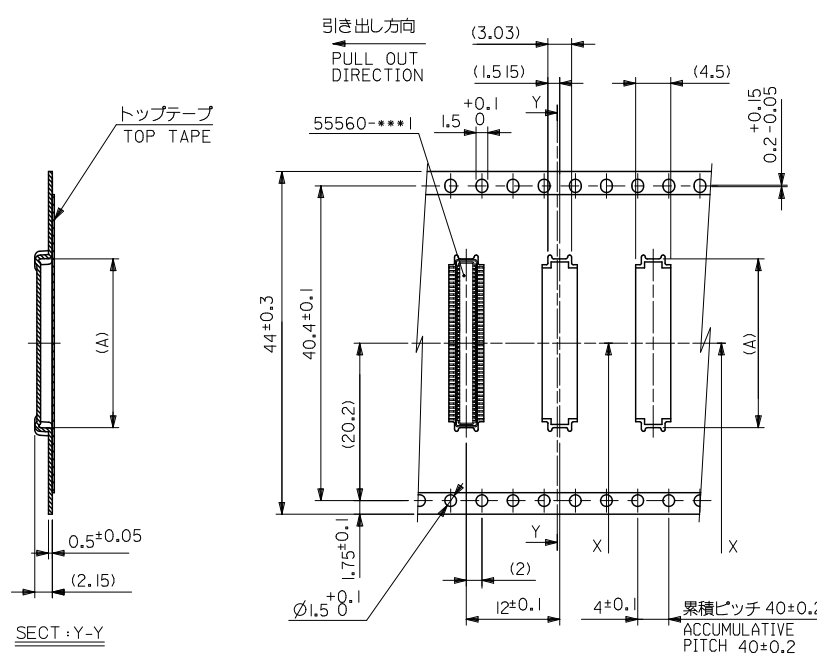

44mm幅キャリアテープ
44mm WIDTH CARRIER TAPE

44	45.5	21.65	55560-0807	55560-***7	80
キャリアテープ幅 CARRIER TAPE WIDTH	B	(A)	MATERIAL No.	MODEL No.	極数 CIRCUIT

REVISED EC NO: J2010-1529 DRW: YON002 CHK: D.S.MARYAMA APPR: M.SASAO 2010/01/28 2010/02/01 2010/02/01	GENERAL TOLERANCES (UNLESS SPECIFIED)		DIMENSION STYLE MM ONLY		SCALE ---	DESIGN UNITS METRIC	THIRD ANGLE PROJECTION
	10 UNDER	±0.2	DRAWN BY S. AIHARA	DATE '00/10/06	TITLE 0.5 B-T0-B PLUG ASSY (HGT=1.5) EMBSTP PKG (SHEET 5 OF 5)		
	10 OVER 30 UNDER	±0.25	CHECKED BY M. SASAO	DATE '03/03/31	MOLEX INCORPORATED		
	30 OVER	±0.3	APPROVED BY M. SASAO	DATE '03/03/31	MATERIAL NO. SEE CHART	DOCUMENT NO. SD-55560-007	SHEET NO. 5 OF 5
ANGULAR ±3 °		DRAFT WHERE APPLICABLE MUST REMAIN WITHIN DIMENSIONS		THIS DRAWING CONTAINS INFORMATION THAT IS PROPRIETARY TO MOLEX INCORPORATED AND SHOULD NOT BE USED WITHOUT WRITTEN PERMISSION			