

PLEASE CHECK WWW.MOLEX.COM FOR LATEST PART INFORMATION

Part Number: [0190180005](#)
Status: **Active**
Description: VibraKrimp™ Quick Disconnect, Female, for 18-22 (0.80-0.35) Wire, Box, Tab 6.35mm (.250") x 0.81mm (.032")

Documents:

[Drawing \(PDF\)](#) [RoHS Certificate of Compliance \(PDF\)](#)
[Product Specification PS-19902-005 \(PDF\)](#)

Agency Certification

CSA LR18689
 UL E79133

General

Product Family Quick Disconnects
 Series 19018
 Comments Butted Seam
 Crimp Quality Equipment Yes
 Product Name VibraKrimp™
 Type Quick Disconnect

Physical

Barrel Type Closed
 Gender Female
 Glow-Wire Compliant No
 Insulation None
 Lock to Mating Part None
 Material - Metal Brass
 Orientation Straight
 Packaging Type Bag
 Polarized to Mating Part No
 Tab Thickness 0.81mm (.032")
 Tab Width 6.35mm (.250")
 Temperature Range - Operating Per Wire Specification
 Wire Insulation Diameter 1.50-3.20mm (.060-.125") max.
 Wire Size AWG 18, 20, 22
 Wire Size mm² 0.35 - 0.80

Electrical

Voltage - Maximum Per Wire Specification

Material Info

Old Part Number AA-4176

Reference - Drawing Numbers

Product Specification PS-19902-005
 Sales Drawing CD51002

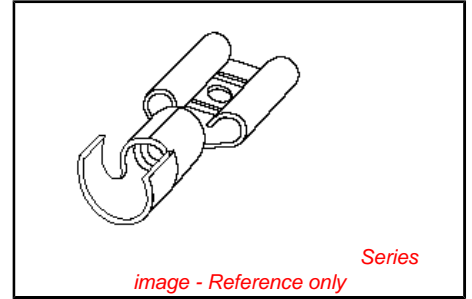

<p>EU RoHS ELV and RoHS Compliant REACH SVHC Contains SVHC: No Halogen-Free Status Halogen-Free</p>	<p>China RoHS</p>
--	--------------------------

Need more information on product environmental compliance?
 Email productcompliance@molex.com
 For a multiple part number RoHS Certificate of Compliance, [click here](#)
 Please visit the [Contact Us](#) section for any non-product compliance questions.

Search Parts in this Series
[19018Series](#)

Application Tooling | FAQ
Tooling specifications and manuals are found by selecting the products below. Crimp Height Specifications are then contained in the Application Tooling Specification document.
Global

Description	Product #
Hand Crimp Tool	0640037200
Crimp Head for the	0640077200
AT-200™ Pneumatic Hand Tool	

PLEASE CHECK WWW.MOLEX.COM FOR LATEST PART INFORMATION

DRWG. NO. CD-51002

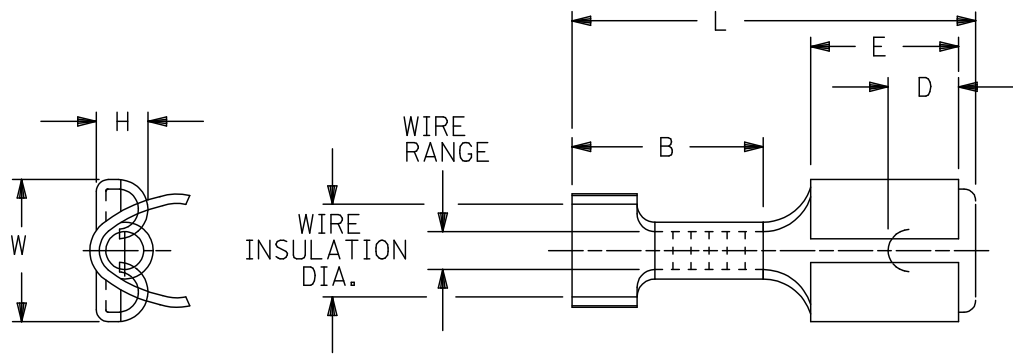

MATERIAL: BRASS

"VIBRAKRIMP"
 CLOSED ELECTRICAL BARREL W/OPEN VIBRATION SUPPORT
 LOOSE PIECE QUICK DISCONNECTS

NON-PLATED PART NUMBER	TIN-PLATED PART NUMBER	AWG WIRE RANGE	FITS MALE TAB SIZE	STOCK THICK.	"L" MAX.	"B" ± 1/64	"W" ± 1/64	"D" ±.01	"H" ± 1/64	"E" ± 1/64	REF. WIRE INSULATION DIAMETER
	AA-4176	22-18	.250x.032	.016	.802	2/64	.301	.156	7/64	.310	.060/.125
	BB-4177	16-14	.250x.032	.016	.802	2/64	.301	.156	7/64	.310	.085/.145
	P-4178	14-12	.250x.032	.016	.802	2/64	.301	.156	7/64	.310	.100/.175

REVISE ONLY ON CAD SYSTEM		CUSTOMER DRAWING	DRWG. BY EMF	molex ETC INC. PINELLAS PARK, FLA. 34665 U.S.A.	SHEET NO.	DATE 01/10/95
TITLE VIBRAKRIMP - LOOSE .250 TAB- QUICK DISCONNECT CLOSED ELEC./OPEN VIB. SUP'T.			CHK'D. BY JM		PART NO. SEE TABLE	DRWG. NO. CD-51002
			APP'D. BY RWD	FILE NAME CD51002	THIS DRAWING CONTAINS INFORMATION THAT IS PROPRIETARY TO MOLEX-ETC INC. AND SHOULD NOT BE USED WITHOUT WRITTEN PERMISSION.	
			SCALE NO:NE		DIV.	SIZE A