

## PN100/PN100A/MMBT100/MMBT100A NPN General Purpose Amplifier

- This device is designed for general purpose amplifier applications at collector currents to 300mA.
- Sourced from process 10.

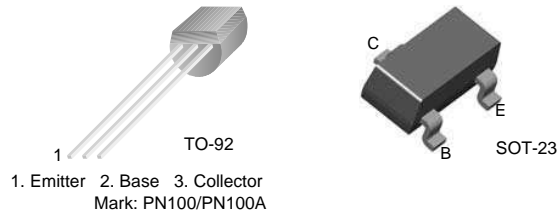

### Absolute Maximum Ratings\* $T_a = 25^\circ\text{C}$ unless otherwise noted

Symbol	Parameter	Ratings	Units
$V_{CEO}$	Collector-Emitter Voltage		45
$V_{CBO}$	Collector-Base Voltage		75
$V_{EBO}$	Emitter-Base Voltage		6.0
$I_C$	Collector current	- Continuous	500
$T_J, T_{stg}$	Junction and Storage Temperature		-55 ~ +150

\* These ratings are limiting values above which the serviceability of any semiconductor device may be impaired.

#### NOTES:

1. These ratings are based on a maximum junction temperature of 150 degrees C.
  2. These are steady state limits. The factory should be consulted on applications involving pulsed or low duty cycle operations.
- \* Pulse Test: Pulse Width $\leq$ 300 $\mu$ s, Duty Cycle $\leq$ 2%

### Thermal Characteristics $T_A = 25^\circ\text{C}$ unless otherwise noted

Symbol	Parameter	Max.		Units
		PN100 PN100A	*MMBT100 *MMBT100A	
$P_D$	Total Device Dissipation	625	350	mW
	Derate above 25°C	5.0	2.8	mW/°C
$R_{\theta JC}$	Thermal Resistance, Junction to Case	83.3		°C/W
$R_{\theta JA}$	Thermal Resistance, Junction to Ambient	200	357	°C/W

\* Device mounted on FR-4 PCB 1.6" x 1.6" x 0.06."

**Electrical Characteristics**  $T_C=25^\circ\text{C}$  unless otherwise noted

Symbol	Parameter	Test Condition	Min.	Max.	Units
<b>Off Characteristics</b>					
$BV_{CBO}$	Collector-Base Breakdown Voltage	$I_C = 10\mu\text{A}, I_E = 0$	75		V
$BV_{CEO}$	Collector-Emitter Breakdown Voltage *	$I_C = 1\text{mA}, I_B = 0$	45		V
$BV_{EBO}$	Emitter-Base Breakdown Voltage	$I_E = 10\mu\text{A}, I_C = 0$	6.0		V
$I_{CBO}$	Collector-Base Cutoff Current	$V_{CB} = 60\text{V}$		50	nA
$I_{CES}$	Collector-Emitter Cutoff Current	$V_{CE} = 40\text{V}$		50	nA
$I_{EBO}$	Emitter Cutoff Current	$V_{EB} = 4\text{V}$		50	nA
<b>On Characteristics</b>					
$h_{FE}$	DC Current Gain	$I_C = 100\mu\text{A}, V_{CE} = 1.0\text{V}$ $I_C = 10\text{mA}, V_{CE} = 1.0\text{V}$ $I_C = 100\text{mA}, V_{CE} = 1.0\text{V}^*$ $I_C = 150\text{mA}, V_{CE} = 5.0\text{V}^*$	100 100A 100 100A 100 100A	80 240 100 300 100 100	  450 600  350
$V_{CE(sat)}$	Collector-Emitter Saturation Voltage	$I_C = 10\text{mA}, I_B = 1.0\text{mA}$ $I_C = 200\text{mA}, I_B = 20\text{mA}$		0.2 0.4	V V
$V_{BE(sat)}$	Base-Emitter Saturation Voltage	$I_C = 10\text{mA}, I_B = 1.0\text{mA}$ $I_C = 200\text{mA}, I_B = 20\text{mA}$		0.85 1.0	V V
<b>Small Signal Characteristics</b>					
$f_T$	Current Gain Bandwidth Product	$V_{CE} = 20\text{V}, I_C = 20\text{mA}$		250	MHz
$C_{obo}$	Output Capacitance	$V_{CB} = 5.0\text{V}, f = 1.0\text{MHz}$		4.5	pF
NF	Noise Figure	$I_C = 100\mu\text{A}, V_{CE} = 5.0\text{V}$ $R_G = 2.0\text{k}\Omega, f = 1.0\text{KHz}$	100 100A	5.0 4.0	dB dB

\* Pulse Test: Pulse Width  $\leq 300\mu\text{s}$ , Duty Cycle  $\leq 2.0\%$

## Typical Characteristics

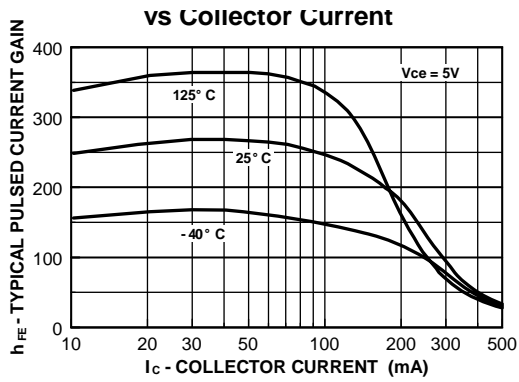

Figure 1. Typical Pulsed Current Gain vs Collector Current

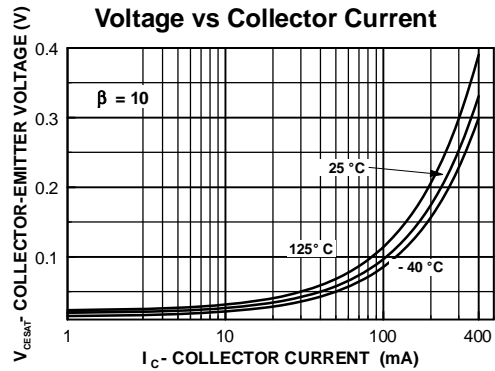

Figure 2. Collector-Emitter Saturation Voltage vs Collector Current

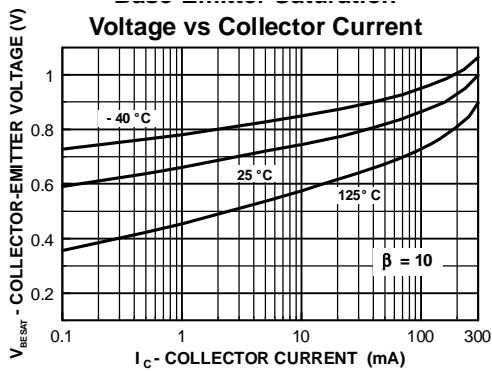

Figure 3. Base-Emitter Saturation Voltage vs Collector Current

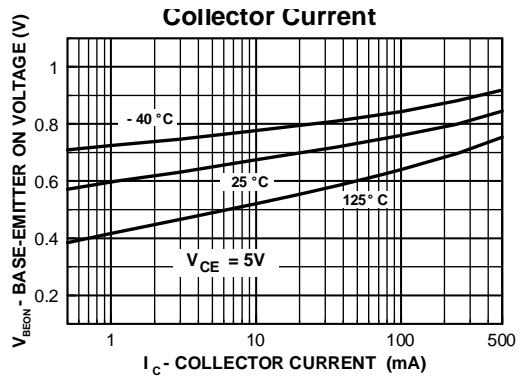

Figure 4. Base-Emitter On Voltage vs Collector Current

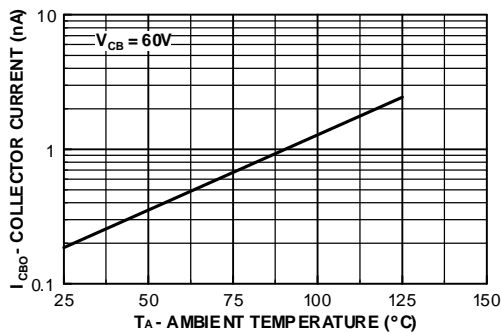

Figure 5. Collector Cutoff Current vs Ambient Temperature

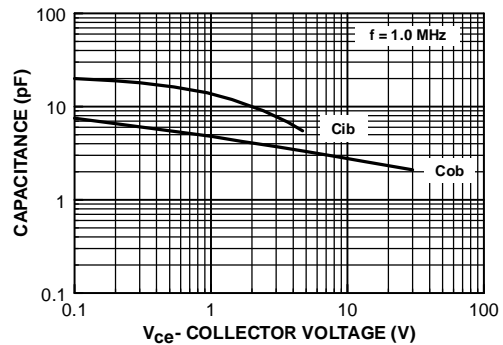

Figure 6. Input and Output Capacitance vs Reverse Voltage

Typical Characteristics (Continued)

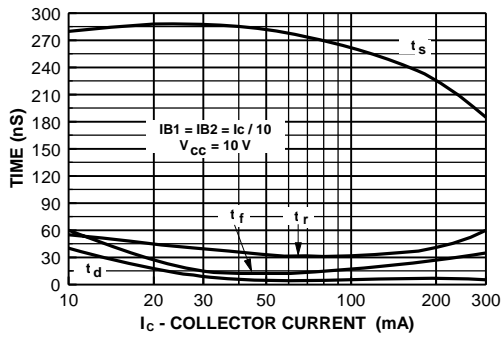

Figure 7. Switching Times vs Collector Current

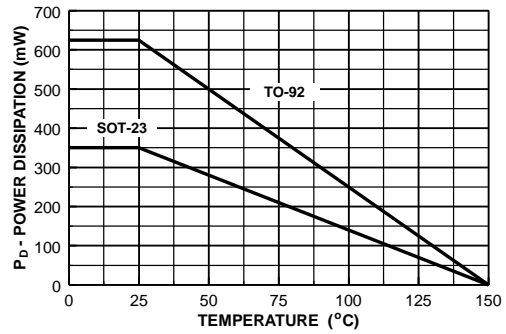
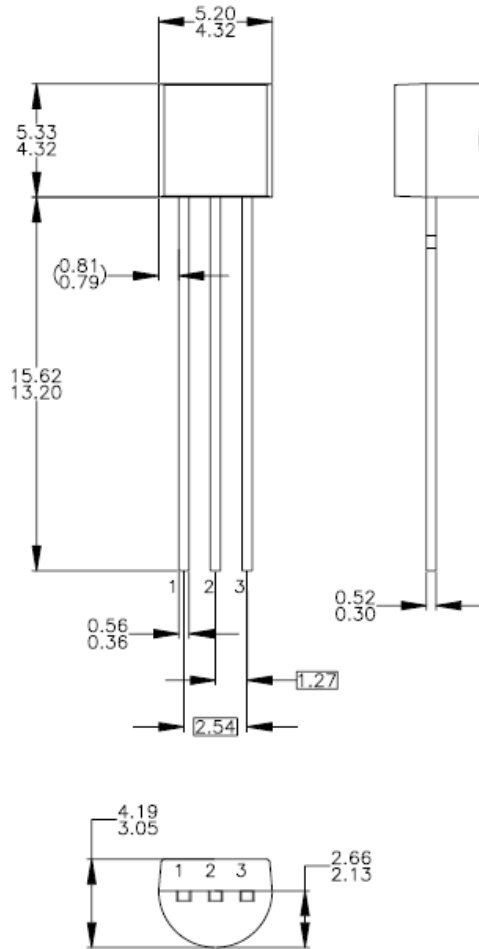

Figure 8. Power Dissipation vs Ambient Temperature

### Package Dimension (TO92)



NOTES: UNLESS OTHERWISE SPECIFIED

- A) DRAWING WITH REFERENCE TO JEDEC TO-92 RECOMMENDATIONS.
- B) ALL DIMENSIONS ARE IN MILLIMETERS.
- C) DRAWING CONFORMS TO ASME Y14.5M-1994.
- D) TO-92 (92,94,96,97,98) PIN CONFIGURATION:

	92			94			96			97			98		
Pin	P	F	M	P	F	M	B	F	M	P	F	M	P	F	M
1	E	S	S	E	S	S	B	D	G	C	G	D	C	G	D
2	B	D	G	C	G	D	E	S	S	B	D	G	E	S	S
3	C	G	D	B	D	G	C	G	D	E	S	S	B	D	G

- LEGEND:  
P - BIPOLAR      E - EMITTER      D - DRAIN  
F - JFET          B - BASE              S - SOURCE  
M - DMOS        C - COLLECTOR      G - GATE
- E) FOR PACKAGE 92, 94, 96, 97 AND 98: PIN CONFIGURATION DRAIN "D" AND SOURCE "S" ARE INTERCHANGEABLE AT JFET "F" OPTION.
  - F) DRAWING FILENAME: MKT-ZA030REV3.

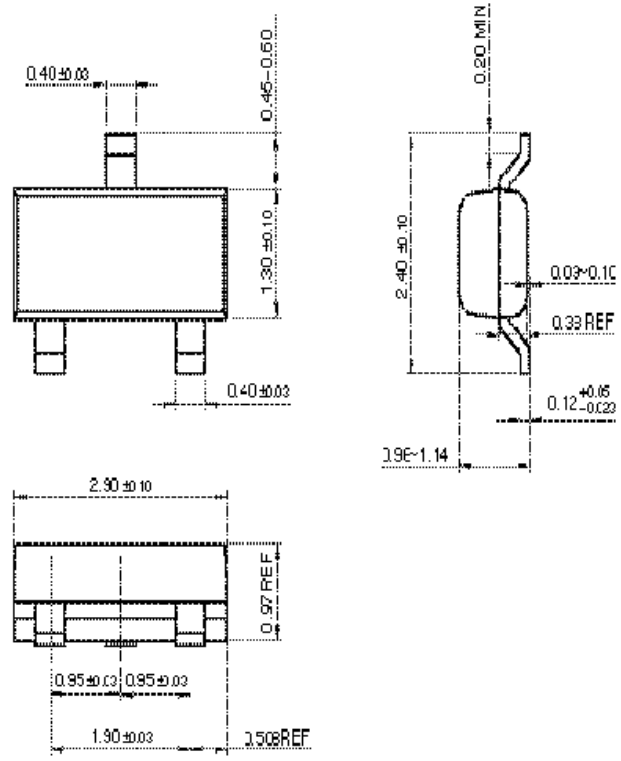

Package Dimension (SOT23)





## TRADEMARKS

The following are registered and unregistered trademarks and service marks Fairchild Semiconductor owns or is authorized to use and is not intended to be an exhaustive list of all such trademarks.

ACEx®	Green FPST™	Power247®	SuperSOT™-8
Build it Now™	Green FPST™ e-Series™	POWEREDGE®	SyncFET™
CorePLUSTM	GTO™	Power-SPM™	The Power Franchise®
CROSSVOLT™	i-Lo™	PowerTrench®	
CTL™	IntelliMAX™	Programmable Active Droop™	TinyBoost™
Current Transfer Logic™	ISOPLANAR™	QFET®	TinyBuck™
EcoSPARK®	MegaBuck™	QST™	TinyLogic®
 Fairchild®	MICROCOUPLER™	QT Optoelectronics™	TINYOPTO™
Fairchild Semiconductor®	MicroFET™	Quiet Series™	TinyPower™
FACT Quiet Series™	MicroPak™	RapidConfigure™	TinyPWM™
FACT®	MillerDrive™	SMART START™	TinyWire™
FAST®	Motion-SPM™	SPM®	µSerDes™
FastvCore™	OPTOLOGIC®	STEALTH™	UHC®
FPS™	OPTOPLANAR®	SuperFET™	UniFET™
FRFET®	 ®	SuperSOT™-3	VCX™
Global Power ResourceSM	PDP-SPM™	SuperSOT™-6	
	Power220®		

## DISCLAIMER

FAIRCHILD SEMICONDUCTOR RESERVES THE RIGHT TO MAKE CHANGES WITHOUT FURTHER NOTICE TO ANY PRODUCTS HEREIN TO IMPROVE RELIABILITY, FUNCTION, OR DESIGN. FAIRCHILD DOES NOT ASSUME ANY LIABILITY ARISING OUT OF THE APPLICATION OR USE OF ANY PRODUCT OR CIRCUIT DESCRIBED HEREIN; NEITHER DOES IT CONVEY ANY LICENSE UNDER ITS PATENT RIGHTS, NOR THE RIGHTS OF OTHERS. THESE SPECIFICATIONS DO NOT EXPAND THE TERMS OF FAIRCHILD'S WORLDWIDE TERMS AND CONDITIONS, SPECIFICALLY THE WARRANTY THEREIN, WHICH COVERS THESE PRODUCTS.

## LIFE SUPPORT POLICY

FAIRCHILD'S PRODUCTS ARE NOT AUTHORIZED FOR USE AS CRITICAL COMPONENTS IN LIFE SUPPORT DEVICES OR SYSTEMS WITHOUT THE EXPRESS WRITTEN APPROVAL OF FAIRCHILD SEMICONDUCTOR CORPORATION.

As used herein:

1. Life support devices or systems are devices or systems which, (a) are intended for surgical implant into the body, or (b) support or sustain life, and (c) whose failure to perform when properly used in accordance with instructions for use provided in the labeling, can be reasonably expected to result in significant injury to the user.
2. A critical component is any component of a life support device or system whose failure to perform can be reasonably expected to cause the failure of the life support device or system, or to affect its safety or effectiveness.

## PRODUCT STATUS DEFINITIONS

### Definition of Terms

Datasheet Identification	Product Status	Definition
Advance Information	Formative or In Design	This datasheet contains the design specifications for product development. Specifications may change in any manner without notice.
Preliminary	First Production	This datasheet contains preliminary data; supplementary data will be published at a later date. Fairchild Semiconductor reserves the right to make changes at any time without notice to improve design.
No Identification Needed	Full Production	This datasheet contains final specifications. Fairchild Semiconductor reserves the right to make changes at any time without notice to improve design.
Obsolete	Not In Production	This datasheet contains specifications on a product that has been discontinued by Fairchild semiconductor. The datasheet is printed for reference information only.

Rev. I31