

Features and Benefits

- Programmable Linear Hall IC
- Quad Switched / Chopper Stabilized
- Ratiometric Output for A/D Interface
- Adjustable Quiescent Voltage (V_{OQ})
- Very Low Quiescent Voltage Temperature Drift
- Adjustable Sensitivity
- Adjustable Temperature Compensation of Sensitivity

Applications

- Linear Position Sensing
- Rotary Position Sensing
- Current Sensing

Ordering Information

Part No.	Temperature Suffix	Package
MLX90215	L (-40°C to 150°C)	VA(4 Lead SIP)
MLX90215	E (-40°C to 85°C)	VA(4 Lead SIP)

Functional Diagram

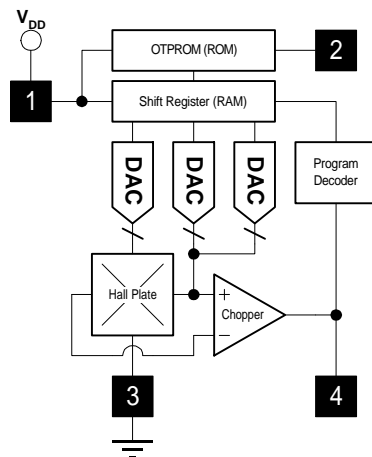

- Pin 1 - V_{DD} (Supply)
 Pin 2 - Test/Readback Enable
 Pin 3 - V_{SS} (Ground)
 Pin 4 - Output

Description

The MLX90215 is a Programmable Linear Hall Effect sensor IC fabricated utilizing silicon-CMOS technology. It possesses active error correction circuitry which virtually eliminates the offset errors normally associated with analog Hall Effect devices. All magnetic response functions of the MLX90215 are fully programmable for even greater versatility. The V_{OQ} ($V_{OUT@ B=0}$), sensitivity, direction of slope and the magnitude of sensitivity drift over temperature, are all programmable.

The ratiometric output voltage is proportional to the supply voltage. When using the supply voltage as a reference for an A/D converter, fluctuations of $\pm 10\%$ in supply voltage will not affect accuracy. When programmed for a conventional sensitivity (with a positive gain), the voltage at the output will increase as a South magnetic field is applied to the branded face of the MLX90215. Conversely, the voltage output will decrease in the presence of a North magnetic field. The MLX90215 has a sensitivity drift of less than $\pm 1\%$ error, and V_{OQ} stability drift of less than $\pm 0.4\%$ error, over a broad temperature range.

Note: Static sensitive device, please observe ESD precautions.

MLX90215 Electrical Specifications

DC Operating Parameters $T_A = -40^{\circ}\text{C}$ to 150°C , $V_{DD} = 5.0\text{V}$ (Unless otherwise specified)

Parameter	Symbol	Test Conditions	Min	Typ	Max	Units
Supply Voltage	V_{DD}	Operating	4.5	5.0	5.5	V
Supply Current	I_{DD}	$B = 0$, $V_{DD} = 5\text{V}$, $I_{OUT} = 0$	2.5	4.0	6.5	mA
Output Current ⁽¹⁾	I_{OUT}	$V_{DD} = 5\text{V} \pm 10\%$	-2	-	2	mA
Quiescent Output Voltage ⁽²⁾	V_{OQ}	10-Bit Programmable, $B = 0$	0.5	-	4.5	V
Output Voltage ⁽¹⁾	V_{OH}	$V_{DD} = 5\text{V}$, $I_{OUT} = -2\text{mA}$	4.50	4.65		V
Output Voltage ⁽¹⁾	V_{OL}	$V_{DD} = 5\text{V}$, $I_{OUT} = 2\text{mA}$		0.35	0.50	V
Sampling Rate	f_{SAMP}	RoughGain @ Max and Min	4	-	40	kHz
Bandwidth ⁽³⁾	BW	RoughGain @ Min		-	1.300	kHz
Bandwidth ⁽³⁾	BW	RoughGain @ Max	0.130	-		kHz
Step Response Time ⁽⁶⁾	T_{RMIN}	RoughGain @ Min	25	-		μs
Step Response Time ⁽⁶⁾	T_{RMIN}	RoughGain @ Max	250			μs
Offset Voltage Adjustment Resolution	ΔV_{OQ}	$B = 0$, $T_A = 25^{\circ}\text{C}$, $1/2 V_{DD} = 1$	-1.5	-	1.5	mV
		$B = 0$, $T_A = 25^{\circ}\text{C}$, $1/2 V_{DD} = 0$	-6.0		6.0	mV
Offset Voltage Drift over Temperature	$\Delta V_{OQ}/\Delta T$	$B = 0$, $T_A = -40^{\circ}\text{C}$ to 150°C $S < 100\text{mV/mT}$ & $V_{OQ} > 0.75\text{V}$	-20	-	20	mV
Offset Voltage Drift ⁽²⁾ over Temperature	$\Delta V_{OQ}/\Delta T$	$B = 0$, $T_A = -40^{\circ}\text{C}$ to 150°C $S > 100\text{mV/mT}$ & $V_{OQ} < 0.75\text{V}$	-40	-	40	mV
Range of Sensitivity ⁽⁷⁾	s	13-Bit Programmable	5	-	140	mV/mT
Peak to Peak Noise ⁽⁴⁾			8	25	60	mV
Output Resistance	R_{OUT}			6		Ω
Sensitivity Drift ⁽⁵⁾		$T_A = 25^{\circ}\text{C}$	-1	-	1	%

Notes:

- (1) If output current and voltage specifications are exceeded, linearity will be degraded.
- (2) If V_{OQ} is programmed beyond these limits, the temperature compensation may become a problem at high temperatures. It is not recommended to program values of V_{OQ} below 1V or above 4V when sensitivity exceeds 100 mV/mT. Temperature instability can occur on some devices under these conditions.
- (3) Bandwidth is related to the sample rate and ROUGHGAIN. Bandwidth is estimated by (sample rate / 30)
- (4) Peak to Peak Noise is a function of ROUGHGAIN setting. See page 5, Peak to Peak Noise versus Sensitivity.
- (5) Sensitivity drift is independent of other parameters and does not include individual tolerances (ΔV_{OQ} or $\Delta V_{OQ}/\Delta T$). The tolerance for sensitivity $\pm 1\%$ of its initial value. This does not include tolerance stack-up.
- (6) If the step input occurs in the middle of a sample interval, the small signal response delay will double. For ROUGHGAIN values less than or equal to 3, response time may be limited by the slew rate.
- (7) 1 mT = 10 Gauss

Melexis Inc. reserves the right to make changes without further notice to any products herein to improve reliability, function, or design. Melexis does not assume any liability arising from the use of any product or application of any product or circuit described herein.

How does it Work?

The MLX90215 programming is done through the output pin, by changing supply voltage levels. Please note that the V_{DD} is raised to approximately 13V and 18V during programming. **Any connected components must also tolerate this voltage excursion.** When the supply voltage is at 4.5V to 5.5V, the output behaves normally. If the supply voltage is raised to 13V, the output then behaves as an input, or LOAD mode, allowing the 37-bit word to be clocked in. All data is loaded through a single line, with no dedicated clock signal. Clock and data are integrated into one signal which is initiated with the beginning of the LOAD sequence, then clocked with the positive edge of each bit. Variables are changed with the PC software and loaded into the temporary register of the device (RAM) via the timings of the programmer's microcontroller. Data can be loaded as many times as desired while in LOAD mode. Once a word is loaded, results are checked by observing the output voltage. This can be done with an external Voltmeter attached directly to pin 4 of the device, or with the internal ADC of the programmer. Once the desired program is loaded, the word can be "Zapped" permanently into ROM.

This is done when the supply voltage rises above 18V, or ZAP mode, creating enough current to "Zap" 31 zener diodes which correspond to the temporary register. The ZAP function is a one-time function and cannot be erased.

The above description is only for reference. The voltage levels and data transfer rates are completely controlled by the ASIC programmer. For more information on the programmer hardware, contact Melexis and request a datasheet for the SDAP programmer.

Programming The Quiescent Offset Voltage (V_{OQ}) 10 bits, 1024 steps of resolution, are allotted to adjust the Quiescent Offset Voltage (V_{OQ}). By utilizing the HALFVDD function, the V_{OQ} can be set to one of two

Table 1 - Programming Offset Voltage (V_{OQ})

HalfVDD	OffsetDAC	Output	Units
0	0	4.97	V
0	512	2.47	V
0	1023	0.03	V
1	0	3.07	V
1	512	2.45	V
1	1023	1.83	V

ranges. With the HALFVDD function disabled, the V_{OQ} can be programmed within a range of 10% to 90% V_{DD} with about 5mV per step resolution. With the HALFVDD function enabled, the device may be programmed within a 2V to 3V window with less than 1mV per step resolution

Programming the Sensitivity (Gain)

The sensitivity is programmed with a ROUGHGAIN and a FINEGAIN adjustment. The ROUGHGAIN is adjusted by utilizing three bits, or 8 increments. The FINEGAIN is programmed with 10 bits or 1024 increments. The sensitivity can be programmed within a range of 5mV/mT to 140mV/mT. Another 1-bit function allows the direction of the sensitivity to be reversed. The INVERTSLOPE function, when activated, will cause the Voltage output of the MLX90215 to decrease in the presence of a South magnetic field, and to increase in the presence of a North magnetic field. Table 2 expresses examples of sensitivity resulting from programming ROUGH GAIN and FINE GAIN codes, with the INVERT SLOPE function turned off.

Note: Tables 1 and 2 are examples how various codes affect the device. Output voltage will vary slightly from device to device. Use these tables for reference only.

Table 2 - Programming Sensitivity

RoughGain	FineGain	Output	Units
0	0	4.1	mV/mT
0	1023	9.4	mV/mT
1	0	6.2	mV/mT
1	1023	14.6	mV/mT
2	0	9.5	mV/mT
2	1023	22.4	mV/mT
3	0	14.2	mV/mT
3	1023	33.1	mV/mT
4	0	21.5	mV/mT
4	1023	50.4	mV/mT
5	0	31.3	mV/mT
5	1023	72.5	mV/mT
6	0	46.2	mV/mT
6	1023	107	mV/mT
7	0	68.9	mV/mT
7	1023	140	mV/mT

Temperature Compensation

Temperature compensation (TC) is defined as the change in sensitivity over temperature. Expressed in (Parts Per Million per Degree Celcius) ppm/°C.

$$TC = \frac{Sens_{T1} - Sens_{T2}}{Sens_{25}} * \frac{1}{T1 - T2} * 10^6 \frac{ppm}{^{\circ}C}$$

Sens_{T1} = Sensitivity measured at Temperature 1 (T1)
Sens_{T2} = Sensitivity measured at Temperature 2 (T2)
Sens₂₅ = Initial Sensitivity measured at 25°C

Table 3 - Temperature Compensation

TC Code	Min	Typical	Max	Units
0	-700	-550	-350	ppm/°C
1	-625	-450	-275	ppm/°C
2	-525	-375	-175	ppm/°C
3	-450	-300	-100	ppm/°C
4	-350	-200	-25	ppm/°C
5	-275	-125	50	ppm/°C
6	-200	-50	125	ppm/°C
7	-100	25	225	ppm/°C
8	125	275	425	ppm/°C
9	225	350	525	ppm/°C
10	300	425	600	ppm/°C
11	375	525	700	ppm/°C
12	450	600	775	ppm/°C
13	525	675	850	ppm/°C
14	600	775	950	ppm/°C
15	675	850	1025	ppm/°C
16	975	1300	1550	ppm/°C
17	1025	1375	1650	ppm/°C
18	1125	1470	1750	ppm/°C
19	1200	1550	1825	ppm/°C
20	1275	1650	1950	ppm/°C
21	1325	1725	2025	ppm/°C
22	1425	1800	2125	ppm/°C
23	1475	1900	2200	ppm/°C
24	1500	2000	2425	ppm/°C
25	1550	2100	2525	ppm/°C
26	1600	2200	2625	ppm/°C
27	1675	2275	2700	ppm/°C
28	1750	2375	2825	ppm/°C
29	1825	2450	2925	ppm/°C
30	1900	2550	3025	ppm/°C
31	1950	2650	3125	ppm/°C

Programming the Temperature Compensation

The MLX90215 has a 5-bit (32 step) programmable adjustment that changes its sensitivity drift over a given temperature range. By adjusting the TC code the sensitivity can be programmed to increase as temperature increases to counteract the decrease in magnetic flux most magnets display over temperature. For example a SmCo (Samarium Cobalt) magnet has a temperature coefficient of approximately -300 ppm/°C. The MLX90215 can be programmed with a TC of 300 ppm/°C to counteract the TC of the magnet and greatly improve linearity in the application over temperature.

Table 3 (left) illustrates the way the TC code affects the sensitivity temperature drift. Also note in Table 3, the overlap in TC codes. The numbers in the table represent typical results and are for reference only. For accurate results the TC code must be determined experimentally. This TC code map applies to MLX90215's with a first line brand showing "215DB"

Special Note

The MLX90215 programmed with a zero TC code (default) has a typical TC value between the range of -300 to -600 ppm/°C. This means sensitivity will decrease slightly as temperature increases. The slightly negative initial TC value allows the MLX90215 to be accurately programmed up to 0 TC. Almost all magnets have a naturally negative TC code. The natural TC of a magnet added with the initial negative TC value of the MLX90215 could degrade linearity over a large temperature span. Using a TC code of 6, 7, or 8 will give the MLX90215 a slightly positive TC code.

Previous revisions of the MLX90215 with second line brand of "15AXX" or "15DXX" should refer to factory for TC code maps.

Diagnostic Characteristics

Condition	Output Level
V _{OUT} Shorted to V _{DD}	V _{OUT} = V _{DD}
V _{OUT} Shorted to V _{SS}	V _{OUT} = V _{SS}
V _{OUT} open with pull up load	V _{OUT} = V _{DD}
V _{OUT} open with pull down load	V _{OUT} = V _{SS}
V _{SS} open with pull up load	V _{OUT} = V _{DD}
V _{SS} open with pull down load > 10 K Ohms	V _{OUT} = V _{DD} or 94% V _{DD}
V _{DD} open with pull up load > 4.7 K Ohms	V _{OUT} = V _{SS} or 3% V _{DD}
V _{DD} open with pull down load	V _{OUT} = V _{SS}

MLX90215 Performance

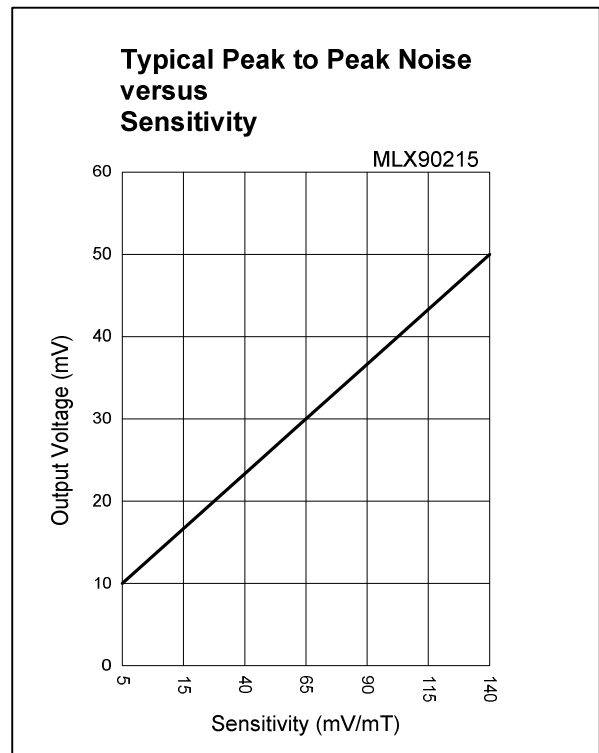
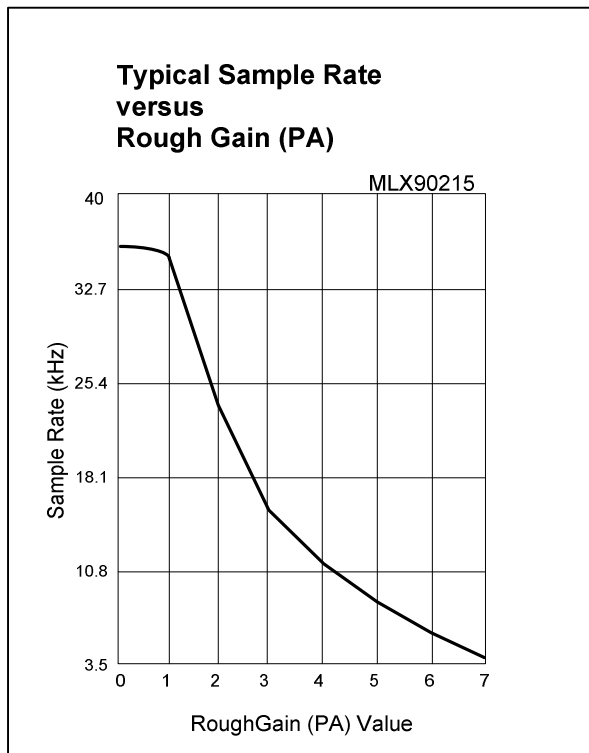
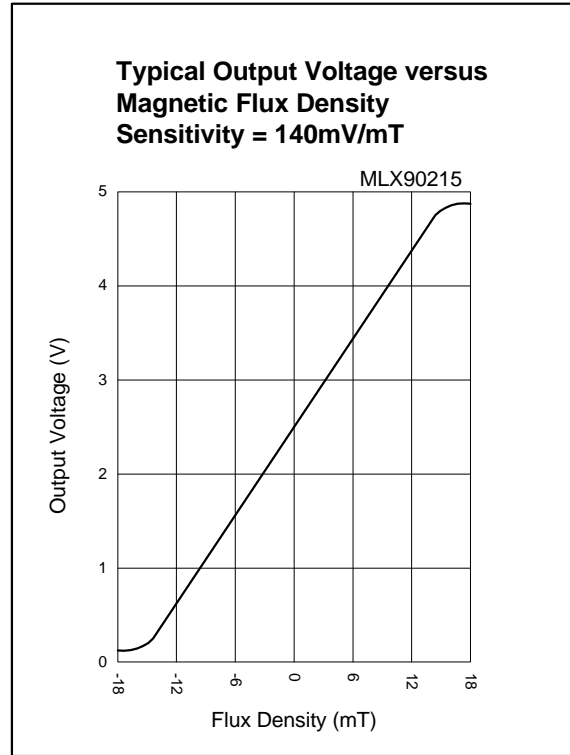
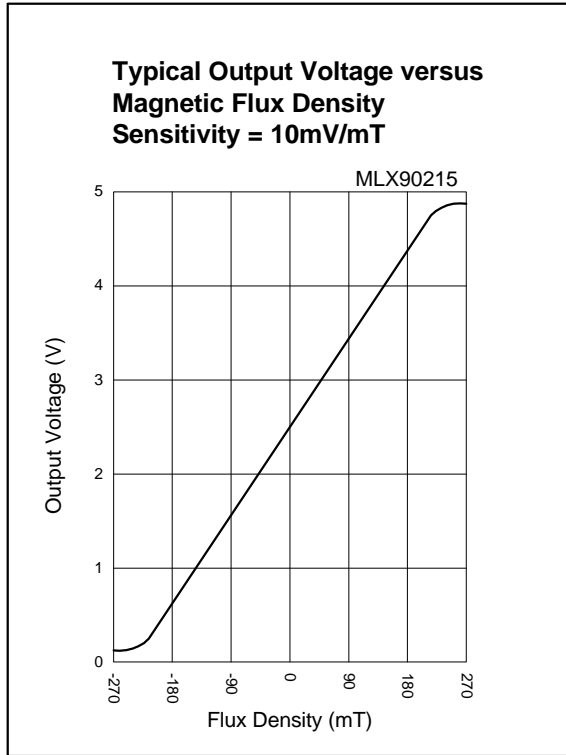

Melexis Programmer

Melexis offers a programmer (PTC-01) for programming the MLX90215. The PTC-01 comes complete with windows based software that makes programming the MLX90215 simple. The programmer communicates with a PC via a RS232 serial interface. The programmer and software allows users to load settings in the MLX90215, take measurements, calibrate sensors, and program the MLX90215. For more information the PTC-01 goto www.melexis.com, or contact Melexis.

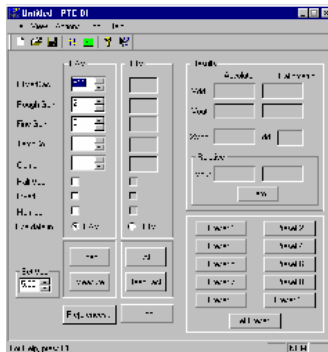

Left, PTC-01 windows based software. Works with any 9 Pin Serial Port equipped PC running windows 9x, W2000 or XP.

Melexis PTC-01 Programmer

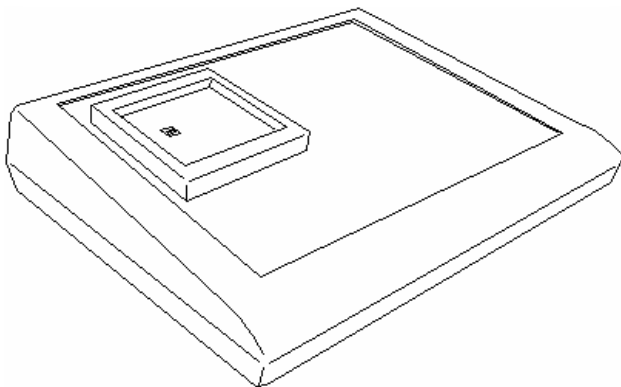

Absolute Maximum Ratings

Supply Voltage (Over Voltage)	18V
Supply Voltage (Operating)	5V \pm 10%
Reverse Voltage Protection	-14.5V
Magnetic Flux Density	Unlimited
Supply Current, I _{DD}	6.5 mA
Output Current (Short to V _{DD})	+12 mA
Output Current (Short to V _{SS})	-12 mA
Operating Temperature Range, T _A	-40° C to 150°C
Storage Temperature Range, T _S	-55° C to 165°C
ESD Sensitivity	\pm 5kV

Pin Description Recommended Wiring

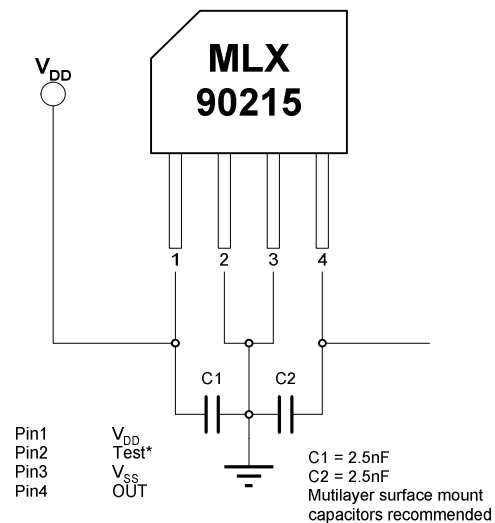

*Readback diagnostic use only. Pin 2 is NOT for programming device. For best results, tie to GND.

Clamping the Output Voltage

The MLX90215 has a 2-bit CLAMP feature which allows Four output voltage options. The CLAMP feature is independent of the gain, and will not effect sensitivity of the device. The table below illustrates limits for each of the four options.

Bit Value	Limits (% V_{DD})
0 (default)	no clamp
1	5 to 45
2	10 to 90
3	5 to 95

Application Comments

The following is a list of recommended operating parameters that will help to ensure the accuracy and stability of the MLX90215. These are not the absolute programming limits of the device.

- 1.) V_{OQ} is best programmed in the absence of any magnetic influence and to voltages closest to $1/2 V_{DD}$, where temperature drift will be $\pm 0.4\%$ or less. It is not recommended to use V_{OQ} values close to 0 volts or V_{DD} when programming extremely high sensitivity (> 100 mV/mT) values. Temperature instability may be observed on some devices under these conditions.
- 2.) Best linearity of sensitivity is obtained when V_{OQ} is programmed at $1/2V_{DD}$. This is with the $1/2V_{DD}$ function enabled.
- 3.) Best linearity of sensitivity is obtained when the gain is programmed between 5mV/mT and 100mV/mT.
- 4.) Best temperature stability is realized when the temperature compensation function is programmed to zero ppm/ $^{\circ}C$.
- 5.) The Test/Readback pin is for diagnostic use only. This pin is normally tied to GND. Contact Melexis for more details on programming this device.

Installation Comments

- 1.) Avoid mechanical stress on leads or package. Stress may cause V_{OQ} shift.
 - A.) Avoid bending leads at the package interface.
 - B.) Support the leads by clamping, when bending.
 - C.) Avoid gluing device to another material. This may cause temperature-related stress.
- 2.) CMOS products are static sensitive devices, please observe ESD precautions.
- 3.) Observe temperature limits during soldering.

Bit Allocation Table

Bit	Function
1	INVERTSLOPE
2	OFFSETDAC 5
3	OFFSETDAC 6
4	OFFSETDAC 7
5	OFFSETDAC 8
6	OFFSETDAC 9
7	OFFSETDAC 4
8	OFFSETDAC 3
9	OFFSETDAC 2
10	OFFSETDAC 1
11	OFFSETDAC 0
12	FINEGAIN 0
13	FINEGAIN 1
14	FINEGAIN 2
15	HALFVDD
16	FINEGAIN 3
17	FINEGAIN 4
18	FINEGAIN 5
19	FINEGAIN 8
20	FINEGAIN 9
21	FINEGAIN 6
22	FINEGAIN 7
23	ROUGHGAIN 2
24	ROUGHGAIN 1
25	ROUGHGAIN 0
26	TEMP CO 0
27	TEMP CO 1
28	TEMP CO 2
29	TEMP CO 3
30	TEMP CO 4
31	CLAMP 1
32	CLAMP 0
33	MEMLOCK
34	TEST 0
35	TEST 1
36	TEST 2
37	TEST 3

Physical Characteristics

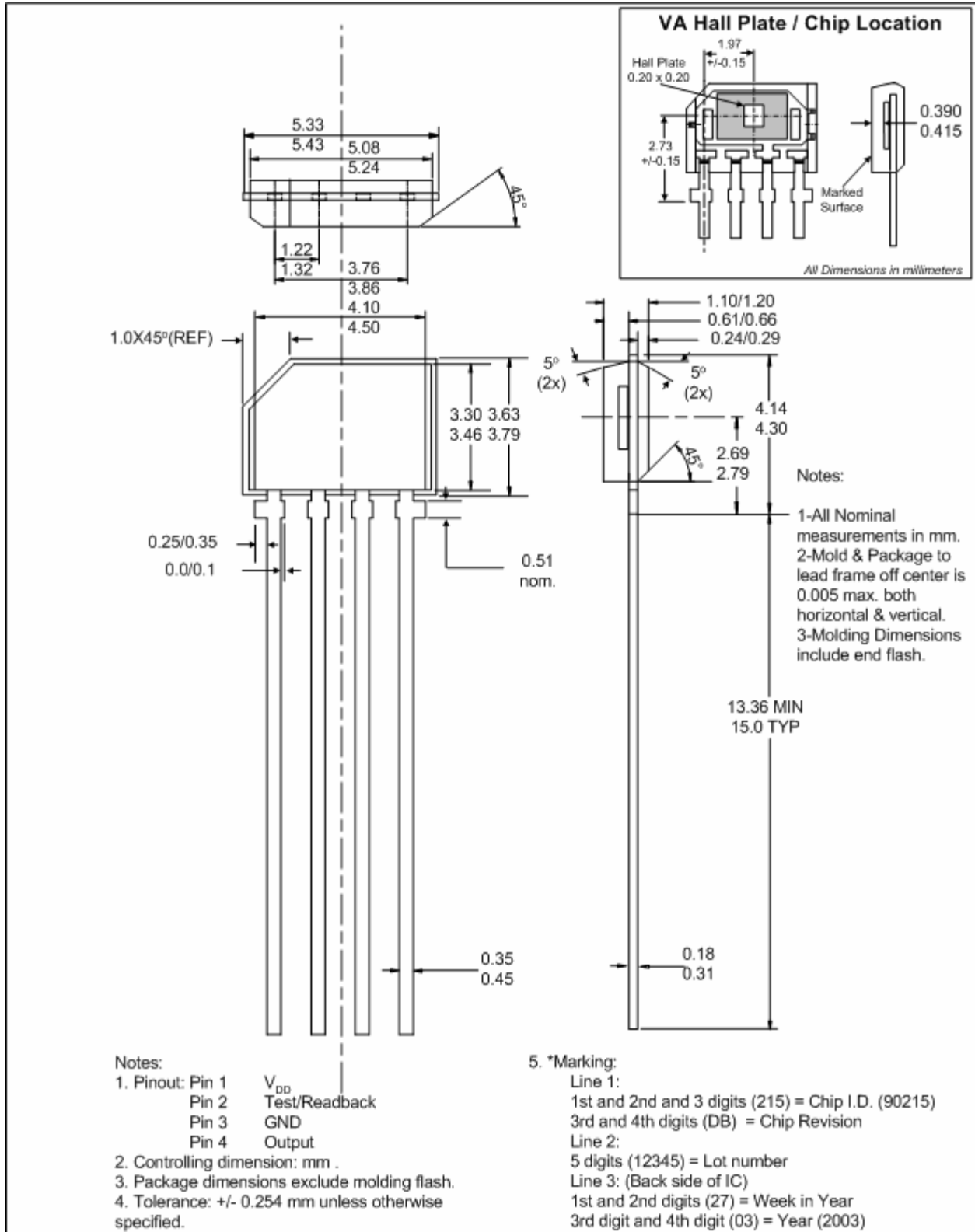

Application Notes

Linear Precision Current Sensor

The Programmable gain, offset, and temperature compensation of MLX90215 allows great flexibility in the design of a current sensor.

Current flowing through a conductor can produce a proportional magnet field. The MLX90215 can then produce an output voltage proportional to the current. Using the programmable gain and offset function the output of the MLX90215 can be adjusted to sense a wide range of current allowing for a flexible design.

Slotted Torroid Example Assuming infinite permeability of the core, the magnetic field through the air gap produced by a single wire turn is given by equation 2

Equation 2

$$B = \frac{I}{l_g} \mu_o$$

Where: I = current in Amperes
 B = magnetic field in Tesla
 l_g = length of air gap in Meters
 μ_o = Permeability of free space ($4\pi 10^{-7} \text{H/m}$)

This equation is a close estimate for the field in the air gap, but does not take into account magnetic losses in the core, fringing effects, and mechanical tolerances of the air gap. The programmable MLX90215 can be adjusted to compensate for these errors simplifying the design. The temperature compensation of MLX90215 can also be adjusted to counteract temperature losses of core.

For sensing a current $\pm 100\text{A}$, with an air gap of 2mm equation 2 yields a magnetic field range of $\pm 63\text{mT}$. The output range of the MLX90215 is 0.5V to 4.5V (4V full scale). Equations 3a and 3b yield a sensitivity of 32mV/mT and a V_{oq} of 2.5V.

Equation 3

- a) $S = 4000\text{mV} / 126\text{mT}$
- b) $V_{oq} = 4\text{V} / 2 + 0.5\text{V}$

The resulting gain of the current sensor is 20mV/A with an offset of 2.5V. For best results it is recommend that MLX90215 be programmed with a V_{oq} of 50% V_{dd} 1/2 V_{dd} bit set.

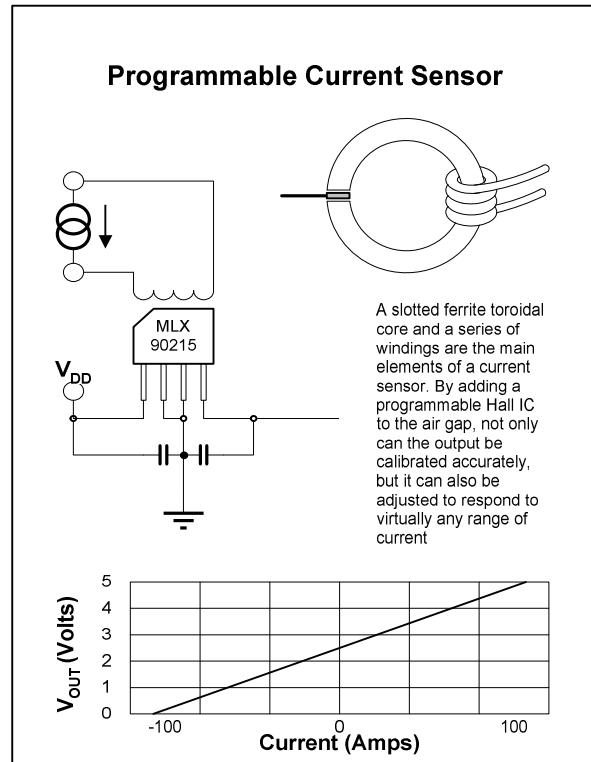

Magnetic Suppliers:

Elna Ferrites Technologies Inc
 Eastern Components
 Fair Rite Products Corp

Reliability Information

Melexis devices are classified and qualified regarding suitability for infrared, vapor phase and wave soldering with usual (63/37 SnPb-) solder (melting point at 183degC).

The following test methods are applied:

IPC/JEDEC J-STD-020A (issue April 1999)
Moisture/Reflow Sensitivity Classification For Nonhermetic Solid State Surface Mount Devices
CECC00802 (issue 1994)
Standard Method For The Specification of Surface Mounting Components (SMDs) of Assessed Quality
MIL 883 Method 2003 / JEDEC-STD-22 Test Method B102
Solderability

For all soldering technologies deviating from above mentioned standard conditions (regarding peak temperature, temperature gradient, temperature profile etc) additional classification and qualification tests have to be agreed upon with Melexis.

The application of Wave Soldering for SMD's is allowed only after consulting Melexis regarding assurance of adhesive strength between device and board.

For more information on manufacturability/solderability see quality page at our website:

<http://www.melexis.com/>

For the latest version of this document, go to our website at:

www.melexis.com

Or for additional information contact Melexis Direct:

Europe and Japan:	All other locations:
Phone: +32 13 67 04 95	Phone: +1 603 223 2362
E-mail: sales_europe@melexis.com	E-mail: sales_usa@melexis.com

QS9000, VDA6.1 and ISO14001 Certified

Disclaimer

Devices sold by Melexis are covered by the warranty and patent indemnification provisions appearing in its Term of Sale. Melexis makes no warranty, express, statutory, implied, or by description regarding the information set forth herein or regarding the freedom of the described devices from patent infringement. Melexis reserves the right to change specifications and prices at any time and without notice. Therefore, prior to designing this product into a system, it is necessary to check with Melexis for current information. This product is intended for use in normal commercial applications. Applications requiring extended temperature range, unusual environmental requirements, or high reliability applications, such as military, medical life-support or life-sustaining equipment are specifically not recommended without additional processing by Melexis for each application.

The information furnished by Melexis is believed to be correct and accurate. However, Melexis shall not be liable to recipient or any third party for any damages, including but not limited to personal injury, property damage, loss of profits, loss of use, interrupt of business or indirect, special incidental or consequential damages, of any kind, in connection with or arising out of the furnishing, performance or use of the technical data herein. No obligation or liability to recipient or any third party shall arise or flow out of Melexis' rendering of technical or other services.

© 2002 Melexis NV. All rights reserved.