

**Product Number: 3966-0-67-15-07-80-10-0**

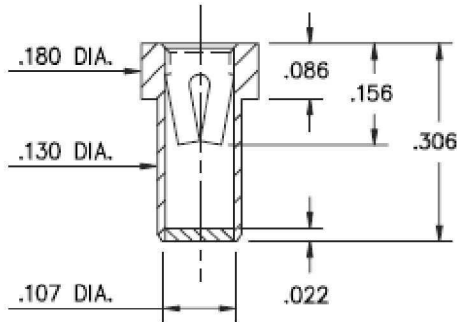

**Description:**

**3966** - Receptacle With OFF Solder Barrier  
Accepts .065-.082 diameter leads.

**Packaging:**

Packaged on Tape & Reel  
650 per 13" reel

**3966-0-XX-XX-07-XX-10-0**

Solder mount in  $\varnothing.135 \pm .003$  PTH.  
#07 Contact for  $\varnothing.065-.082$  pins.  
Also available on 24mm wide carrier tape: 950 parts per 13" reel.

Mill-Max Part Number	Shell Plating	Contact Plating	RoHS Compliant
3966-0-67-15-07-80-10-0	10 $\mu$ " Gold over Nickel	200 - 300 $\mu$ " Tin (matte finish) over Nickel	

**CONTACT:**

Contact Used: #07, Standard 4 Finger Contact  
Current Rating = 15 Amps

**BERYLLIUM COPPER ALLOY 172 (UNS C17200)** per ASTM B 194

**Properties of BERYLLIUM COPPER:**

- Chemical composition: Cu 98.1%, Be 1.9%
- Temper as stamped: TD01

Properties after heat treatment (TH01):

- Hardness: 36-43 Rockwell C
- Mechanical Life: 100 Cycles Min.
- Density: .298 lbs/in<sup>3</sup>
- Electrical Conductivity: 22% IACS\*
- Resistance: 10 milliohms Max
- Operating Temperature: -55°C/+125°C
- Melting point: 980°C/865°C (liquidus/solidus)
- Stress Relaxation†: 96% of stress remains after 1,000 hours @ 100 °C ; 70% of stress remains after 1,000 hours @ 200 °C

\*International Annealed Copper Standard, i.e. as a % of pure copper.

†Since BeCu loses its spring properties over time at high temperatures; it is rated for continuous use up to 150°C. For applications up to 300°C, Mill-Max offers many contacts in Beryllium Nickel. Contact Tech Support for more info.

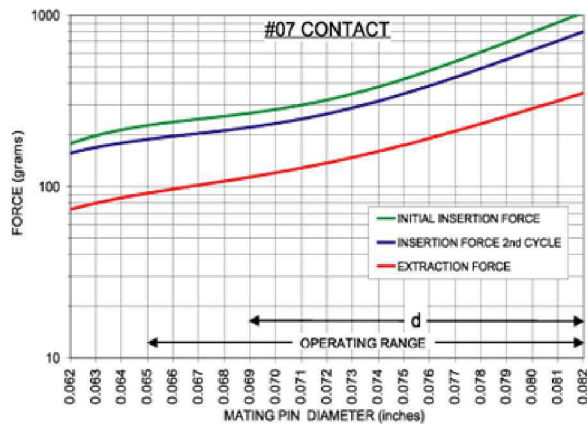

The insertion/extraction/normal force characteristics above were derived using a 30 microinch gold plated contact and polished steel gauge pins having a bullet-shaped tip.

The curves represent typical average values. The charts only guide you in selecting a clip that is close to your specification. Your results may vary, so for your specification, we encourage you to obtain complimentary samples for your evaluation.

**SHELL MATERIAL:****BRASS ALLOY** (UNS C36000) per ASTM B 16**Properties of BRASS ALLOY:**

- Chemical composition: Cu 61.5%, Zn 35.4%, Pb 3.1%†
- Hardness as machined: 80-90 Rockwell B
- Density: .307 lbs/in<sup>3</sup>
- Electrical conductivity: 26% IACS\*
- Melting point: 900°C/885°C (liquidus/solidus)

†(3 to 4% lead is used to permit "free machining" and is permitted by EC Directive 2002/95Annex 6; so all pin materials are RoHS compliant)

\*International Annealed Copper Standard, i.e. as a % of pure copper.