

DUAL-IN-LINE SOCKETS

SERIES 113 • SURFACE MOUNT, STUB TAIL W/ ALIGNMENT PINS • OPEN FRAME

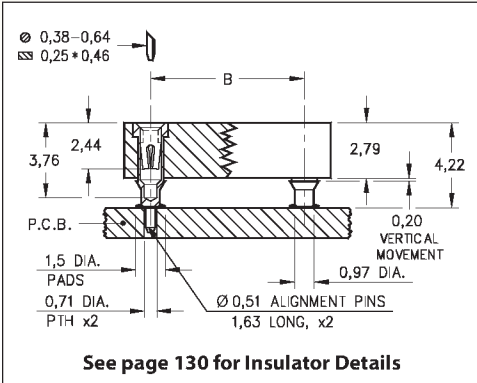

- Unique floating contacts compensate for the effects of unevenly dispensed solder paste
- Two corner alignment pins (power & ground positions) permit manual placement
- Hi-Rel, 4-finger BeCu #30 contact is rated at 3 amps. See page 253 for details
- Series 113 uses MM #1334 and #1434 pins. See pages 162 and 171
- Insulators are high temperature thermoplastic, suitable for all soldering operations
- For Electrical, Mechanical and Environmental Data, see page 264 for details

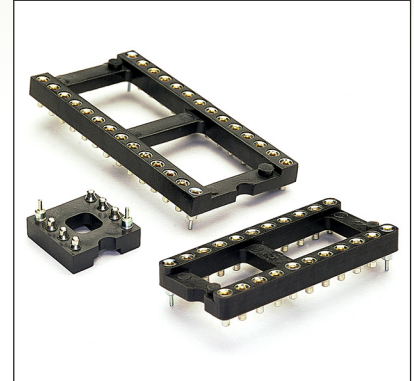

Total number of pins	ALIGNMENT PINS			Quantity per tube	ORDERING INFORMATION			
	A	B	C					
10	12,6	5,08	7,6	41	113-XX-210-41-117000			
4	5,0	7,62	10,1	100	113-XX-304-41-117000			
6	7,6	7,62	10,1	67	113-XX-306-41-117000			
8	10,1	7,62	10,1	50	113-XX-308-41-117000			
10	12,6	7,62	10,1	40	113-XX-310-41-117000			
14	17,7	7,62	10,1	28	113-XX-314-41-117000			
16	20,3	7,62	10,1	25	113-XX-316-41-117000			
18	22,8	7,62	10,1	22	113-XX-318-41-117000			
20	25,3	7,62	10,1	20	113-XX-320-41-117000			
22	27,8	7,62	10,1	18	113-XX-322-41-117000			
24	30,4	7,62	10,1	16	113-XX-324-41-117000			
28	35,5	7,62	10,1	14	113-XX-328-41-117000			
20	25,4	10,16	12,7	20	113-XX-420-41-117000			
22	27,8	10,16	12,7	18	113-XX-422-41-117000			
24	30,4	10,16	12,7	16	113-XX-424-41-117000			
28	35,5	10,16	12,7	14	113-XX-428-41-117000			
32	40,6	10,16	12,7	12	113-XX-432-41-117000			
24	30,4	15,24	17,7	16	113-XX-624-41-117000			
28	35,5	15,24	17,7	14	113-XX-628-41-117000			
32	40,6	15,24	17,7	12	113-XX-632-41-117000			
36	45,7	15,24	17,7	11	113-XX-636-41-117000			
40	50,8	15,24	17,7	10	113-XX-640-41-117000			
42	53,3	15,24	17,7	9	113-XX-642-41-117000			
48	60,9	15,24	17,7	8	113-XX-648-41-117000			
50	63,5	15,24	17,7	8	113-XX-650-41-117000			
52	66,0	15,24	17,7	7	113-XX-652-41-117000			
50	63,5	22,86	25,3	8	113-XX-950-41-117000			
52	66,0	22,86	25,3	7	113-XX-952-41-117000			
64	81,2	22,86	25,3	6	113-XX-964-41-117000			
XX=Plating Code See Below					RoHS-2 2011/65/EU			
SPECIFY PLATING CODE XX =					93	43		
Sleeve (Pin)				5,08µm Sn/Pb	5,08µm Sn			
Contact (Clip)				0,25µm Au	0,25µm Au			

