

0344

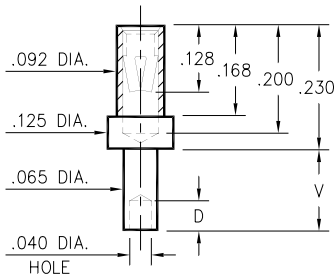

Basic Part Number	Board Thickness	Length V	Depth D
0344-1	.031	.062	.040
0344-2	.062	.094	.062
0344-3	.094	.125	.062
0344-4	.125	.156	.062

0344-X-19-XX-34-XX-10-0
Swage mount in .067 hole

0349

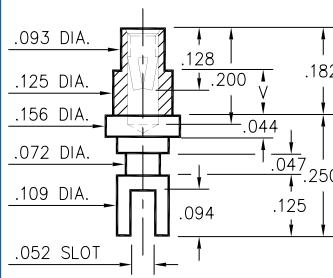

Basic Part Number	Board Thickness	Length V
0349-2	.062	.094
0349-3	.094	.125
0349-4	.125	.156

0349-X-31-XX-34-XX-10-0
Swage mount in .129 hole

0323/0324

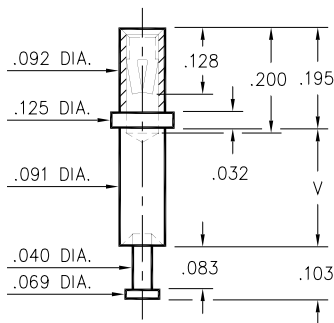

0323-X-15-XX-34-XX-10-0
Swage mount in .094 hole

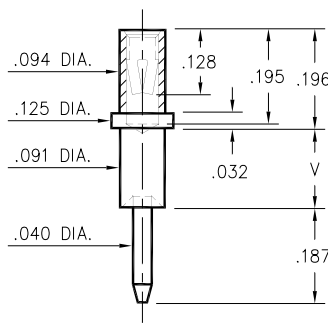

0324-X-15-XX-34-XX-10-0
Swage mount in .094 hole

Basic Part Number	Board Thickness	Length V
032X-1	.031	.062
032X-2	.062	.094
032X-3	.094	.125
032X-4	.125	.156
032X-5	.188	.219

0348

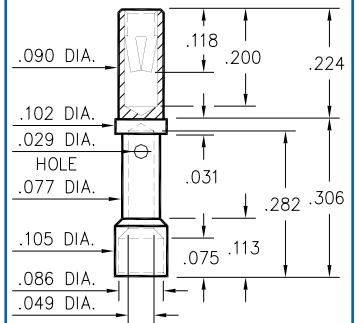

0348-0-33-XX-34-XX-10-0
#20A Crimp Barrel

0405

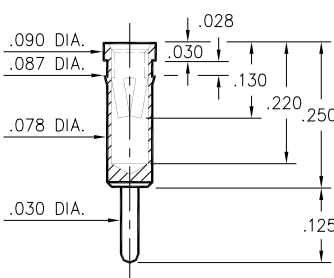

0405-0-15-XX-34-XX-04-0
Press-fit in .084 mounting hole

0336

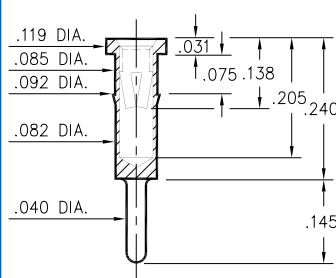

0336-0-15-XX-34-XX-04-0
Press-fit in .089 mounting hole

0322

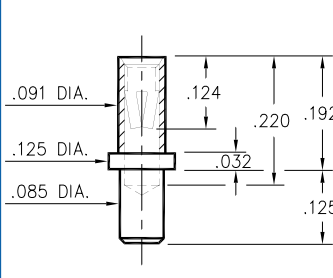

0322-0-15-XX-34-XX-10-0
Solder mount in .089 min. mounting hole

0325

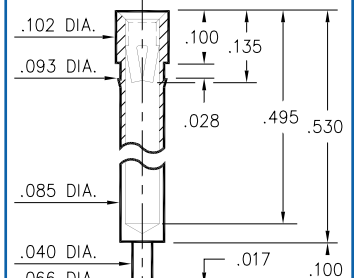

0325-0-15-XX-34-XX-10-0
Press-fit in .090 mounting hole

SPECIFICATIONS

SHELL MATERIAL:
Brass Alloy 360, 1/2 Hard

CONTACT MATERIAL:
Beryllium Copper Alloy 172, HT

DIMENSION IN INCHES
TOLERANCES ON:
LENGTHS: ±.005
DIAMETERS: ±.002
ANGLES: ± 2°

ORDER CODE: XXXX - X - XX - XX - 34 - XX - XX - 0

BASIC PART # →

SPECIFY SHELL FINISH: →

01 200μ" TIN/LEAD OVER NICKEL
15 10μ" GOLD OVER NICKEL

SPECIFY CONTACT FINISH:

01 200μ" TIN/LEAD OVER NICKEL
14 10μ" GOLD OVER NICKEL
27 30μ" GOLD OVER NICKEL

↑
CONTACT

↑
#34 CONTACT (DATA ON PAGE 212)