

The SST89E516RDx and SST89V516RDx are members of the FlashFlex family of 8-bit microcontroller products designed and manufactured with SST's patented and proprietary SuperFlash CMOS semiconductor process technology. The split-gate cell design and thick-oxide tunneling injector offer significant cost and reliability benefits for SST's customers. The devices use the 8051 instruction set and are pin-for-pin compatible with standard 8051 microcontroller devices.

Features

- **8-bit 8051-Compatible Microcontroller (MCU) with Embedded SuperFlash Memory**
 - Fully Software Compatible
 - Development Toolset Compatible
 - Pin-For-Pin Package Compatible
- **SST89E516RD2 Operation**
 - 0 to 40 MHz at 5V
- **SST89V516RD2 Operation**
 - 0 to 33 MHz at 3V
- **1 KByte Internal RAM**
- **Dual Block SuperFlash EEPROM**
 - 64 KByte primary block + 8 KByte secondary block (128-Byte sector size for both blocks)
 - Individual Block Security Lock with SoftLock
 - Concurrent Operation during In-Application Programming (IAP)
 - Memory Overlay for Interrupt Support during IAP
- **Support External Address Range up to 64 KByte of Program and Data Memory**
- **Three High-Current Drive Ports (16 mA each)**
- **Three 16-bit Timers/Counters**
- **Full-Duplex, Enhanced UART**
 - Framing Error Detection
 - Automatic Address Recognition
- **Ten Interrupt Sources at 4 Priority Levels**
 - Four External Interrupt Inputs
- **Programmable Watchdog Timer (WDT)**
- **Programmable Counter Array (PCA)**
- **Four 8-bit I/O Ports (32 I/O Pins) and One 4-bit Port**
- **Second DPTR register**
- **Low EMI Mode (Inhibit ALE)**
- **SPI Serial Interface**
- **Standard 12 Clocks per cycle, the device has an option to double the speed to 6 clocks per cycle.**
- **TTL- and CMOS-Compatible Logic Levels**
- **Brown-out Detection**
- **Low Power Modes**
 - Power-down Mode with External Interrupt Wake-up
 - Idle Mode
- **Temperature Ranges:**
 - Commercial (0°C to +70°C)
 - Industrial (-40°C to +85°C)
- **Packages Available**
 - 40-contact WQFN (Port 4 feature not available)
 - 44-lead PLCC
 - 40-pin PDIP (Port 4 feature not available)
 - 44-lead TQFP
- **All non-Pb (lead-free) devices are RoHS compliant**

Product Description

The SST89E516RDx and SST89V516RDx are members of the FlashFlex family of 8-bit microcontroller products designed and manufactured with SST's patented and proprietary SuperFlash CMOS semiconductor process technology. The split-gate cell design and thick-oxide tunneling injector offer significant cost and reliability benefits for SST's customers. The devices use the 8051 instruction set and are pin-for-pin compatible with standard 8051 microcontroller devices.

The devices come with 72 KByte of on-chip flash EEPROM program memory which is partitioned into 2 independent program memory blocks. The primary Block 0 occupies 64 KByte of internal program memory space and the secondary Block 1 occupies 8 KByte of internal program memory space.

The 8-KByte secondary block can be mapped to the lowest location of the 64 KByte address space; it can also be hidden from the program counter and used as an independent EEPROM-like data memory.

In addition to the 72 KByte of EEPROM program memory on-chip and 1024 x8 bits of on-chip RAM, the devices can address up to 64 KByte of external program memory and up to 64 KByte of external RAM.

The flash memory blocks can be programmed via a standard 87C5x OTP EPROM programmer fitted with a special adapter and the firmware for SST's devices. During power-on reset, the devices can be configured as either a slave to an external host for source code storage or a master to an external host for an in-application programming (IAP) operation. The devices are designed to be programmed in-system and in-application on the printed circuit board for maximum flexibility. The devices are pre-programmed with an example of the bootstrap loader in the memory, demonstrating the initial user program code loading or subsequent user code updating via the IAP operation. The sample bootstrap loader is available for the user's reference and convenience only; SST does not guarantee its functionality or usefulness. Chip-Erase or Block-Erase operations will erase the pre-programmed sample code.

Functional Blocks

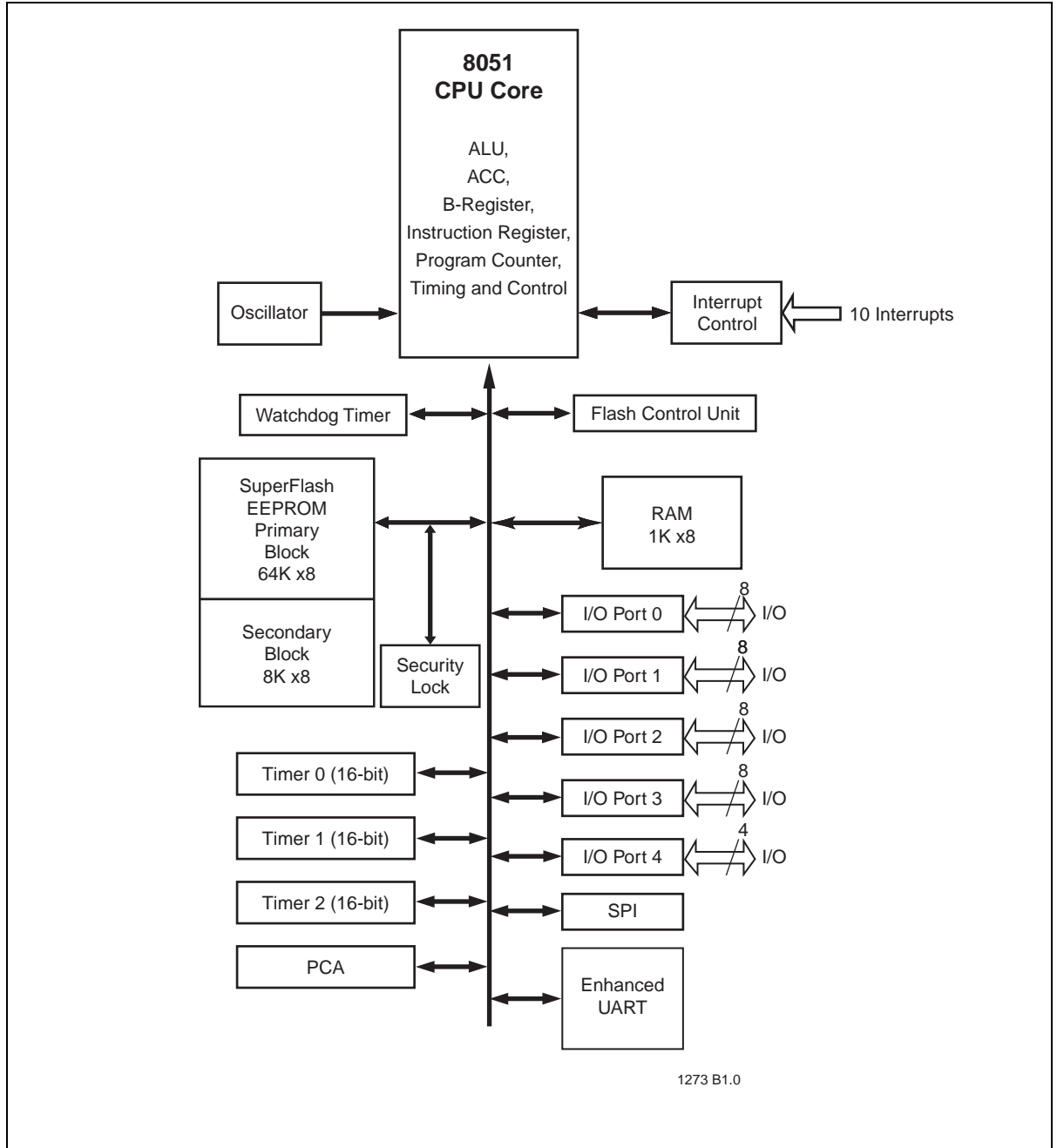

Figure 1: Functional Block Diagram

Pin Assignments

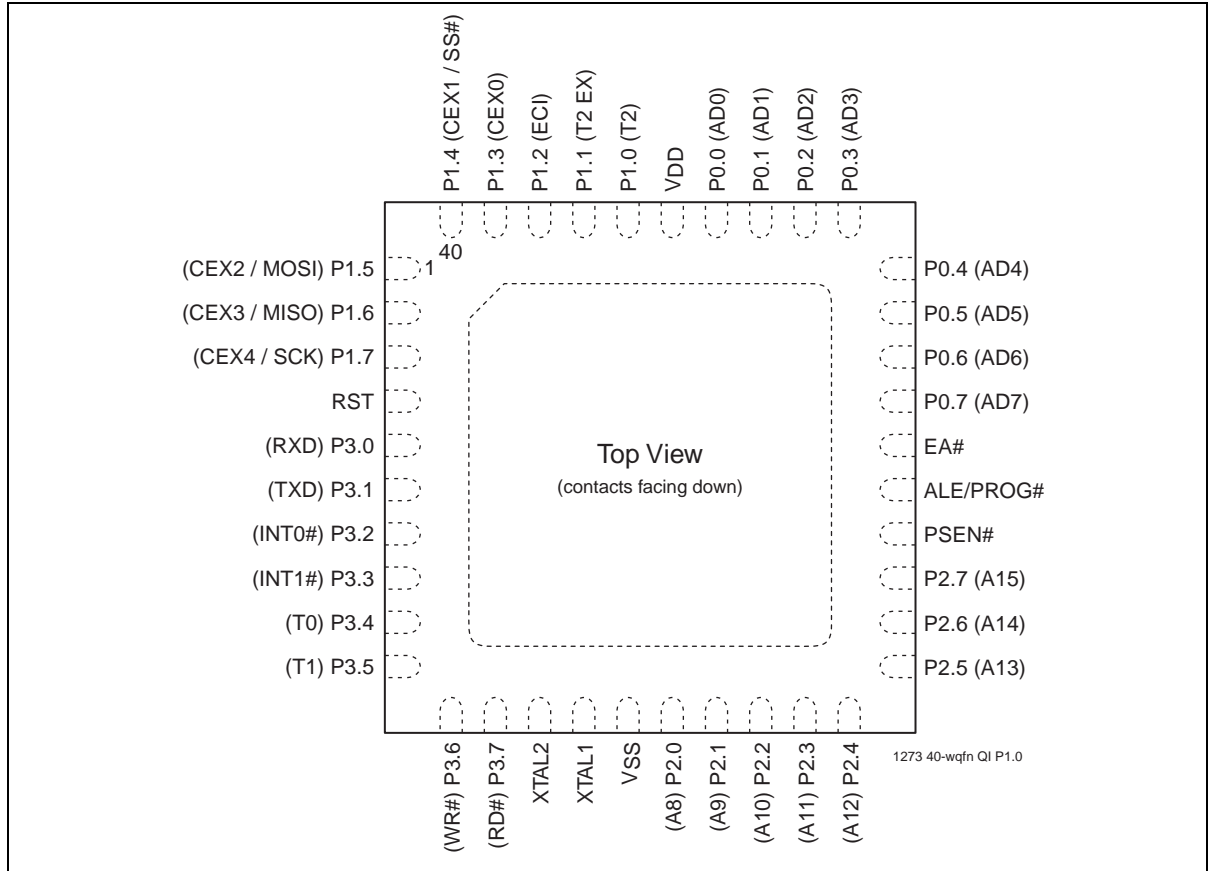

Figure 2: Pin Assignments for 40-Contact WQFN

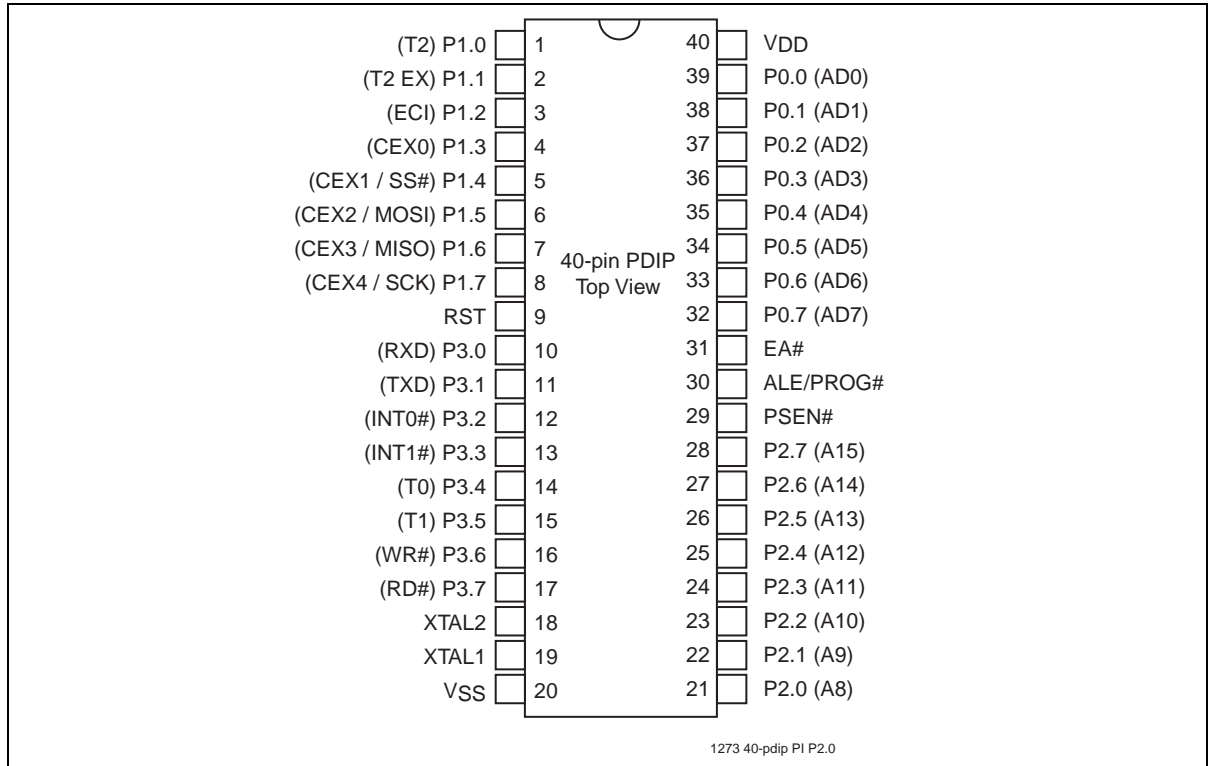

Figure 3: Pin Assignments for 40-pin PDIP

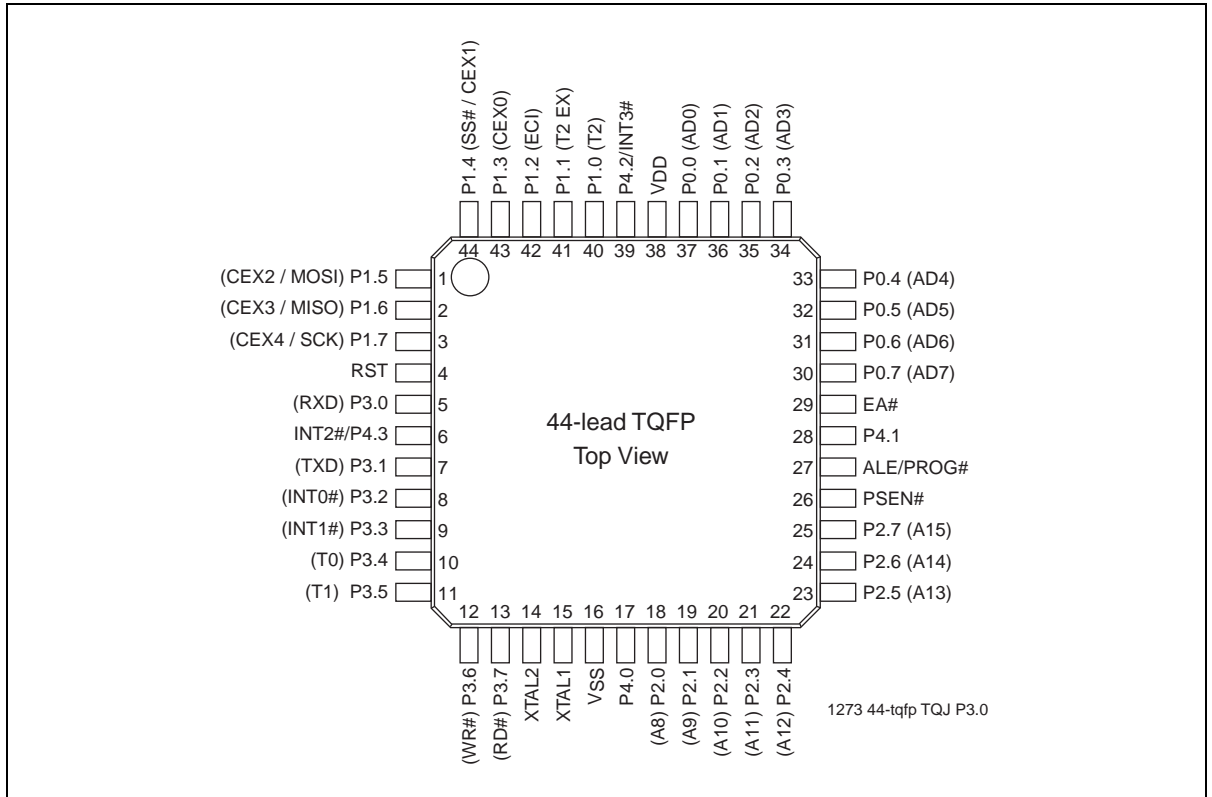

Figure 4: Pin Assignments for 44-lead TQFP

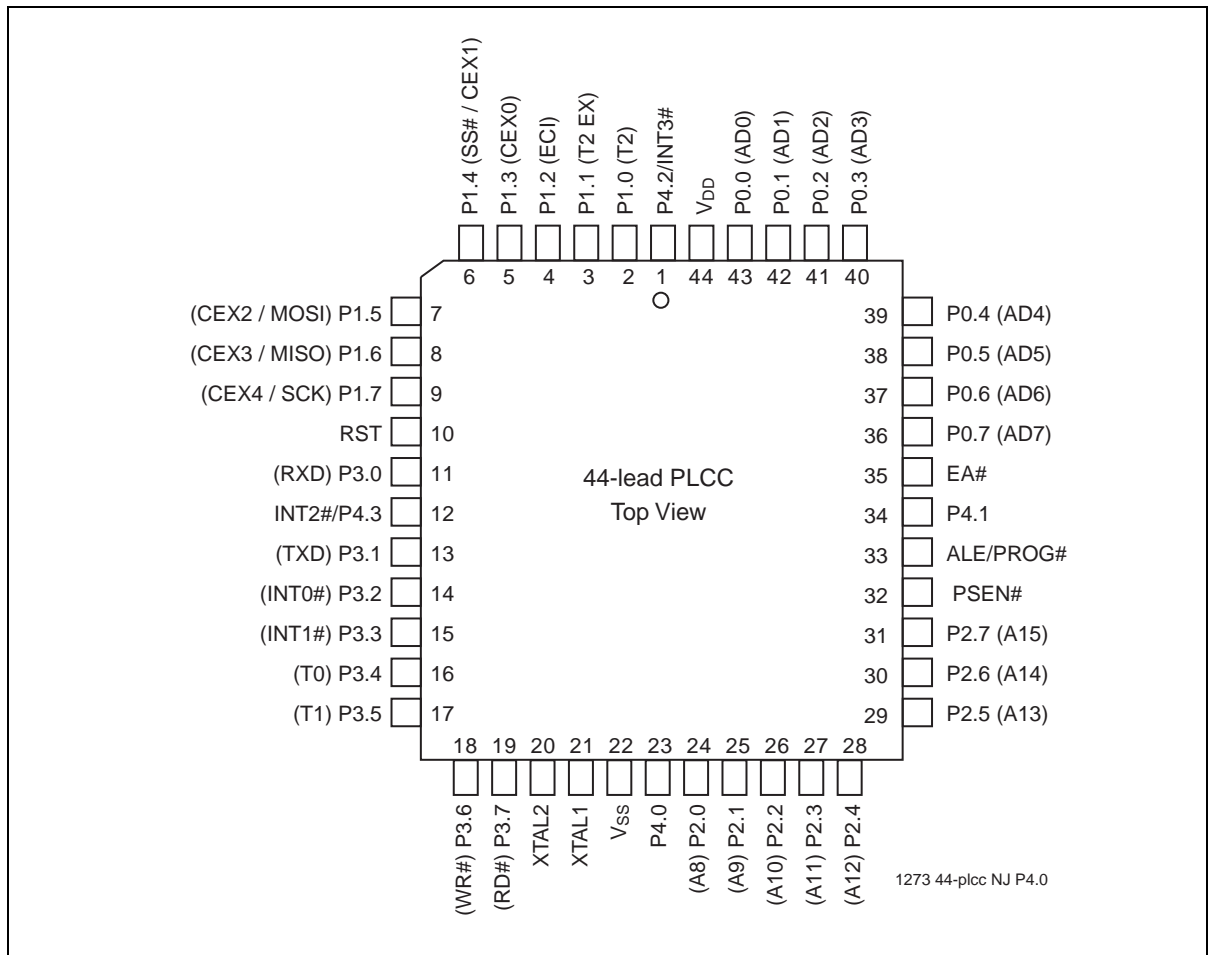

Figure 5: Pin Assignments for 44-lead PLCC

Pin Descriptions

Table 1: Pin Descriptions (1 of 3)

Symbol	Type ¹	Name and Functions
P0[7:0]	I/O	Port 0: Port 0 is an 8-bit open drain bi-directional I/O port. As an output port each pin can sink several LS TTL inputs. Port 0 pins float that have '1's written to them, and in this state can be used as high-impedance inputs. Port 0 is also the multiplexed low-order address and data bus during accesses to external memory. In this application, it uses strong internal pull-ups when transitioning to V_{OH} . Port 0 also receives the code bytes during the external host mode programming, and outputs the code bytes during the external host mode verification. External pull-ups are required during program verification.
P1[7:0]	I/O with internal pull-ups	Port 1: Port 1 is an 8-bit bi-directional I/O port with internal pull-ups. The Port 1 output buffers can drive LS TTL inputs. Port 1 pins are pulled high by the internal pull-ups when "1"s are written to them and can be used as inputs in this state. As inputs, Port 1 pins that are externally pulled low will source current because of the internal pull-ups. P1[5, 6, 7] have high current drive of 16 mA. Port 1 also receives the low-order address bytes during the external host mode programming and verification.
P1[0]	I/O	T2: External count input to Timer/Counter 2 or Clock-out from Timer/Counter 2
P1[1]	I	T2EX: Timer/Counter 2 capture/reload trigger and direction control
P1[2]	I	ECI: PCA Timer/Counter External Input: This signal is the external clock input for the PCA timer/counter.
P1[3]	I/O	CEX0: Compare/Capture Module External I/O Each compare/capture module connects to a Port 1 pin for external I/O. When not used by the PCA, this pin can handle standard I/O.
P1[4]	I/O	SS#: Master Input or Slave Output for SPI. OR CEX1: Compare/Capture Module External I/O
P1[5]	I/O	MOSI: Master Output line, Slave Input line for SPI OR CEX2: Compare/Capture Module External I/O
P1[6]	I/O	MISO: Master Input line, Slave Output line for SPI OR CEX3: Compare/Capture Module External I/O
P1[7]	I/O	SCK: Master clock output, slave clock input line for SPI OR CEX4: Compare/Capture Module External I/O
P2[7:0]	I/O with internal pull-up	Port 2: Port 2 is an 8-bit bi-directional I/O port with internal pull-ups. Port 2 pins are pulled high by the internal pull-ups when "1"s are written to them and can be used as inputs in this state. As inputs, Port 2 pins that are externally pulled low will source current because of the internal pull-ups. Port 2 sends the high-order address byte during fetches from external Program memory and during accesses to external Data Memory that use 16-bit address (MOVX@DPTR). In this application, it uses strong internal pull-ups when transitioning to V_{OH} . Port 2 also receives some control signals and high-order address bits during the external host mode programming and verification.

Table 1: Pin Descriptions (Continued) (2 of 3)

Symbol	Type ¹	Name and Functions
P3[7:0]	I/O with internal pull-up	Port 3: Port 3 is an 8-bit bidirectional I/O port with internal pull-ups. The Port 3 output buffers can drive LS TTL inputs. Port 3 pins are pulled high by the internal pull-ups when “1”s are written to them and can be used as inputs in this state. As inputs, Port 3 pins that are externally pulled low will source current because of the internal pull-ups. Port 3 also receives some control signals and a partial of high-order address bits during the external host mode programming and verification.
P3[0]	I	RXD: Universal Asynchronous Receiver/Transmitter (UART) - Receive input
P3[1]	O	TXD: UART - Transmit output
P3[2]	I	INT0#: External Interrupt 0 Input
P3[3]	I	INT1#: External Interrupt 1 Input
P3[4]	I	T0: External count input to Timer/Counter 0
P3[5]	I	T1: External count input to Timer/Counter 1
P3[6]	O	WR#: External Data Memory Write strobe
P3[7]	O	RD#: External Data Memory Read strobe
PSEN#	I/O	Program Store Enable: PSEN# is the Read strobe to External Program Store. When the device is executing from Internal Program Memory, PSEN# is inactive (V_{OH}). When the device is executing code from External Program Memory, PSEN# is activated twice each machine cycle, except when access to External Data Memory while one PSEN# activation is skipped in each machine cycle. A forced high-to-low input transition on the PSEN# pin while the RST input is continually held high for more than ten machine cycles will cause the device to enter External Host mode for programming.
RST	I	Reset: While the oscillator is running, a high logic state on this pin for two machine cycles will reset the device. After a reset, if the PSEN# pin is driven by a high-to-low input transition while the RST input pin is held high, the device will enter the External Host mode, otherwise the device will enter the Normal operation mode.
EA#	I	External Access Enable: EA# must be driven to V_{IL} in order to enable the device to fetch code from the External Program Memory. EA# must be driven to V_{IH} for internal program execution. However, Security lock level 4 will disable EA#, and program execution is only possible from internal program memory. The EA# pin can tolerate a high voltage ² of 12V.
ALE/ PROG#	I/O	Address Latch Enable: ALE is the output signal for latching the low byte of the address during an access to external memory. This pin is also the programming pulse input (PROG#) for flash programming. Normally the ALE ³ is emitted at a constant rate of 1/6 the crystal frequency ⁴ and can be used for external timing and clocking. One ALE pulse is skipped during each access to external data memory. However, if AO is set to 1, ALE is disabled.
P4[3:0] ⁵	I/O with internal pull-ups	Port 4: Port 4 is an 4-bit bi-directional I/O port with internal pull-ups. The port 4 output buffers can drive LS TTL inputs. Port 4 pins are pulled high by the internal pull-ups when ‘1’s are written to them and can be used as inputs in this state. As inputs, port 4 pins that are externally pulled low will source current because of the internal pull-ups.
P4[0]	I/O	Bit 0 of port 4
P4[1]	I/O	Bit 1 of port 4
P4[2] / INT3#	I/O	Bit 2 of port 4 / INT3# External interrupt 3 input

Table 1: Pin Descriptions (Continued) (3 of 3)

Symbol	Type ¹	Name and Functions
P4[3] / INT2#	I/O	Bit 3 of port 4 / INT2# External interrupt 2 input
XTAL1	I	Crystal 1: Input to the inverting oscillator amplifier and input to the internal clock generator circuits.
XTAL2	O	Crystal 2: Output from the inverting oscillator amplifier
V _{DD}	I	Power Supply
V _{SS}	I	Ground

TO-0.0 25093

1. I = Input; O = Output
2. It is not necessary to receive a 12V programming supply voltage during flash programming.
3. ALE loading issue: When ALE pin experiences higher loading (>30pf) during the reset, the MCU may accidentally enter into modes other than normal working mode. The solution is to add a pull-up resistor of 3-50 KΩ to V_{DD}, e.g. for ALE pin.
4. For 6 clock mode, ALE is emitted at 1/3 of crystal frequency.
5. Port 4 is not present on the PDIP and WQFN packages.

Memory Organization

The device has separate address spaces for program and data memory.

Program Flash Memory

There are two internal flash memory blocks in the device. The primary flash memory block (Block 0) has 64 KByte. The secondary flash memory block (Block 1) has 8 KByte. Since the total program address space is limited to 64 KByte, the SFCF[1:0] bit are used to control program bank selection. Please refer to Figure 6 for the program memory configuration. Program bank selection is described in the next section.

The 64K x8 primary SuperFlash block is organized as 512 sectors, each sector consists of 128 Bytes.

The 8K x8 secondary SuperFlash block is organized as 64 sectors, each sector consists also of 128 Bytes.

For both blocks, the 7 least significant program address bits select the byte within the sector. The remainder of the program address bits select the sector within the block.

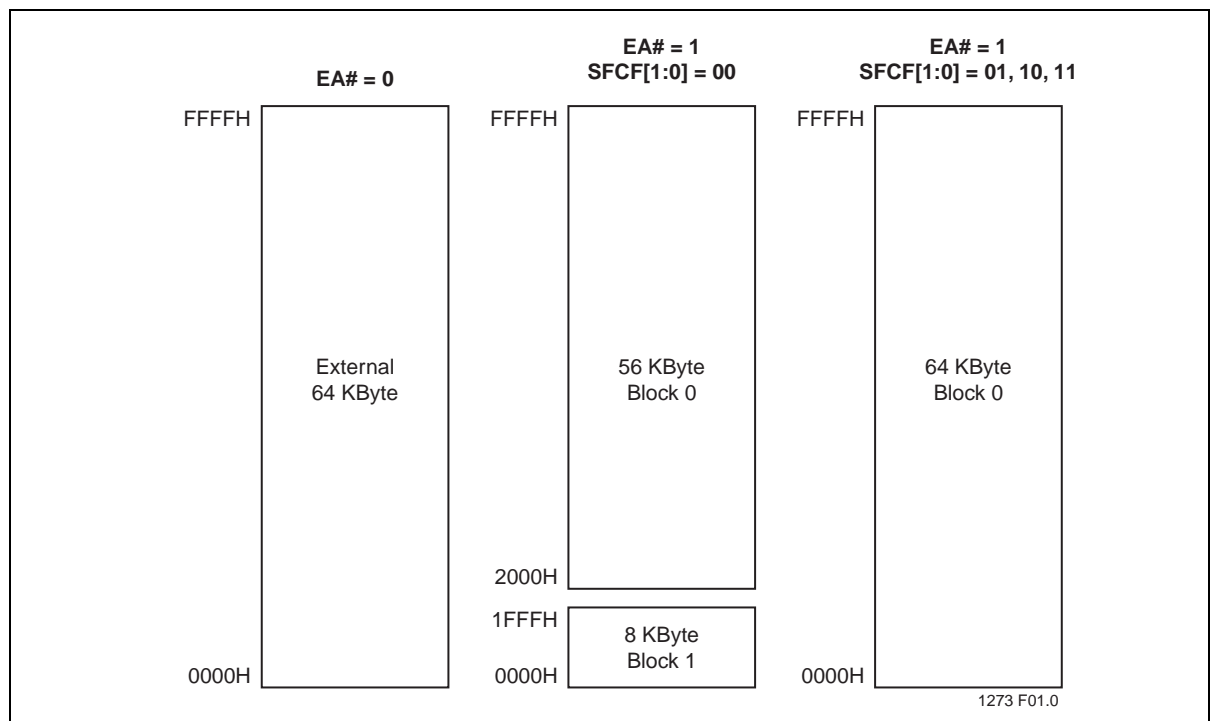

Figure 6: Program Memory Organization

Program Memory Block Switching

The program memory block switching feature of the device allows either Block 1 or the lowest 8 KByte of Block 0 to be used for the lowest 8 KByte of the program address space. SFCF[1:0] controls program memory block switching.

Table 2: SFCF Values for Program Memory Block Switching

SFCF[1:0]	Program Memory Block Switching
01, 10, 11	Block 1 is not visible to the program counter (PC). Block 1 is reachable only via in-application programming from 0000H - 1FFFH.
00	Block 1 is overlaid onto the low 8K of the program address space; occupying address locations 0000H - 1FFFH. When the PC falls within 0000H - 1FFFH, the instruction will be fetched from Block 1 instead of Block 0. Outside of 0000H - 1FFFH, Block 0 is used. Locations 0000H - 1FFFH of Block 0 are reachable through in-application programming.

T0-0.0 25093

Reset Configuration of Program Memory Block Switching

Program memory block switching is initialized after reset according to the state of the Start-up Configuration bit SC0. The SC0 bit is programmed via an external host mode command or an IAP Mode command. See Table 14.

Once out of reset, the SFCF[0] bit can be changed dynamically by the program for desired effects. Changing SFCF[0] will not change the SC0 bit.

Caution must be taken when dynamically changing the SFCF[0] bit. Since this will cause different physical memory to be mapped to the logical program address space. The user must avoid executing block switching instructions within the address range 0000H to 1FFFH.

Table 3: SFCF Values Under Different Reset Conditions

SC0 ¹	State of SFCF[1:0] after:		
	Power-on or External Reset	WDT Reset or Brown-out Reset	Software Reset
U (1)	00 (default)	x0	10
P (0)	01	x1	11

T0-0.0 25093

1. P = Programmed (Bit logic state = 0),
U = Unprogrammed (Bit logic state = 1)

Data RAM Memory

The data RAM has 1024 bytes of internal memory. The RAM can be addressed up to 64KB for external data memory.

Expanded Data RAM Addressing

The SST89E/V516RDx have the capability of 1 KByte RAM. See Figure 7.

The device has four sections of internal data memory:

1. The lower 128 Bytes of RAM (00H to 7FH) are directly and indirectly addressable.
2. The higher 128 Bytes of RAM (80H to FFH) are indirectly addressable.
3. The special function registers (80H to FFH) are directly addressable only.
4. The expanded RAM of 768 Bytes (00H to 2FFH) is indirectly addressable by the move external instruction (MOVX) and clearing the EXTRAM bit. (See “Auxiliary Register (AUXR)” in Section , “Special Function Registers”)

Since the upper 128 Bytes occupy the same addresses as the SFRs, the RAM must be accessed indirectly. The RAM and SFRs space are physically separate even though they have the same addresses.

When instructions access addresses in the upper 128 Bytes (above 7FH), the MCU determines whether to access the SFRs or RAM by the type of instruction given. If it is indirect, then RAM is accessed. If it is direct, then an SFR is accessed. See the examples below.

Indirect Access:

```
MOV@R0, #data; R0 contains 90H
```

Register R0 points to 90H which is located in the upper address range. Data in “#data” is written to RAM location 90H rather than port 1.

Direct Access:

```
MOV90H, #data; write data to P1
```

Data in “#data” is written to port 1. Instructions that write directly to the address write to the SFRs.

To access the expanded RAM, the EXTRAM bit must be cleared and MOVX instructions must be used. The extra 768 bytes of memory is physically located on the chip and logically occupies the first 768 bytes of external memory (addresses 000H to 2FFH).

When EXTRAM = 0, the expanded RAM is indirectly addressed using the MOVX instruction in combination with any of the registers R0, R1 of the selected bank or DPTR. Accessing the expanded RAM does not affect ports P0, P3.6 (WR#), P3.7 (RD#), or P2. With EXTRAM = 0, the expanded RAM can be accessed as in the following example.

Expanded RAM Access (Indirect Addressing only):

```
MOVX@DPTR, A; DPTR contains 0A0H
```

DPTR points to 0A0H and data in “A” is written to address 0A0H of the expanded RAM rather than external memory. Access to external memory higher than 2FFH using the MOVX instruction will access external memory (0300H to FFFFH) and will perform in the same way as the standard 8051, with P0 and P2 as data/address bus, and P3.6 and P3.7 as write and read timing signals.

When EXTRAM = 1, MOVX @Ri and MOVX @DPTR will be similar to the standard 8051. Using MOVX @Ri provides an 8-bit address with multiplexed data on Port 0. Other output port pins can be used to output higher order address bits. This provides external paging capabilities. Using MOVX @DPTR generates a 16-bit address. This allows external addressing up the 64K. Port 2 provides the

high-order eight address bits (DPH), and Port 0 multiplexes the low order eight address bits (DPL) with data. Both MOVX @Ri and MOVX @DPTR generates the necessary read and write signals (P3.6 - WR# and P3.7 - RD#) for external memory use. Table 4 shows external data memory RD#, WR# operation with EXTRAM bit.

The stack pointer (SP) can be located anywhere within the 256 bytes of internal RAM (lower 128 bytes and upper 128 bytes). The stack pointer may not be located in any part of the expanded RAM.

Table 4: External Data Memory RD#, WR# with EXTRAM bit

AUXR	MOVX @DPTR, A or MOVX A, @DPTR		MOVX @Ri, A or MOVX A, @Ri
	ADDR < 0300H	ADDR >= 0300H	ADDR = Any
EXTRAM = 0	RD# / WR# not asserted	RD# / WR# asserted	RD# / WR# not asserted ¹
EXTRAM = 1	RD# / WR# asserted	RD# / WR# asserted	RD# / WR# asserted

T0-0.0 25093

1. Access limited to ERAM address within 0 to 0FFH; cannot access 100H to 02FFH.

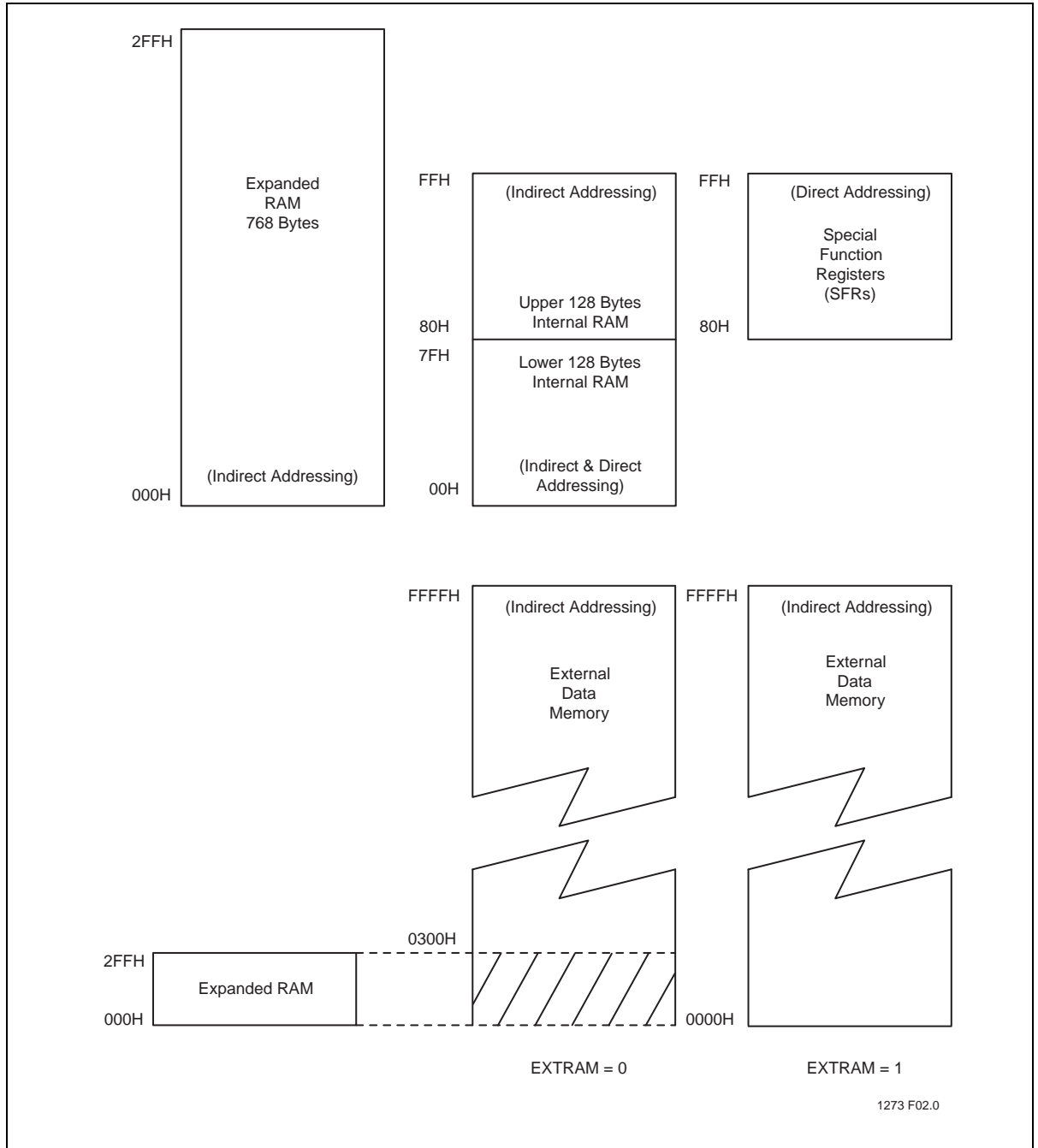

Figure 7: Internal and External Data Memory Structure

Dual Data Pointers

The device has two 16-bit data pointers. The DPTR Select (DPS) bit in AUXR1 determines which of the two data pointers is accessed. When DPS=0, DPTR0 is selected; when DPS=1, DPTR1 is selected. Quickly switching between the two data pointers can be accomplished by a single INC instruction on AUXR1. (See Figure 8)

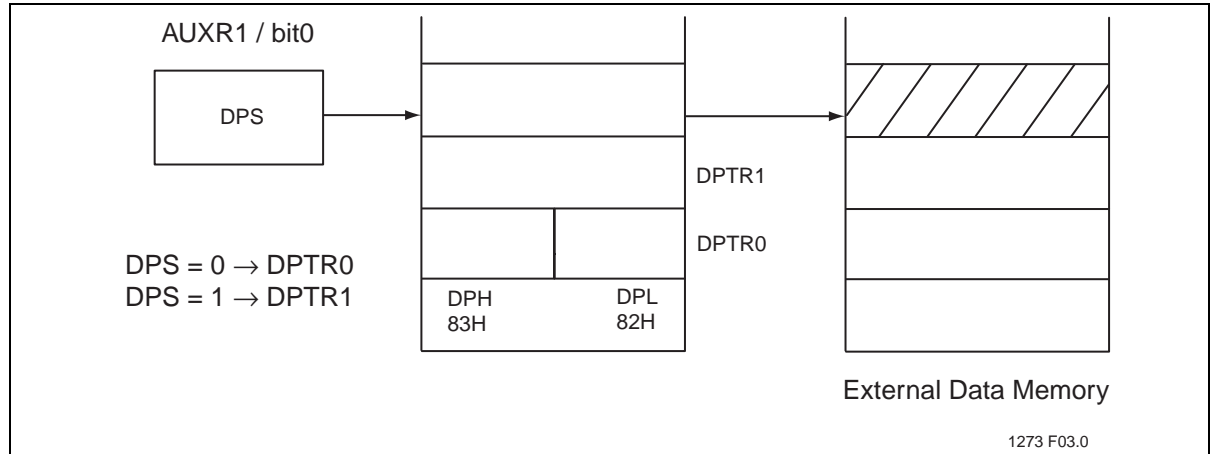

Figure 8: Dual Data Pointer Organization

Special Function Registers

Most of the unique features of the FlashFlex microcontroller family are controlled by bits in special function registers (SFRs) located in the SFR memory map shown in Table 5. Individual descriptions of each SFR are provided and reset values indicated in Tables 6 to 10.

Table 5: FlashFlex SFR Memory Map

8 BYTES								
F8H	IP1 ¹	CH	CCAP0H	CCAP1H	CCAP2H	CCAP3H	CCAP4H	FFH
F0H	B ¹						IP1H	F7H
E8H	IEA ¹	CL	CCAP0L	CCAP1L	CCAP2L	CCAP3L	CCAP4L	EFH
E0H	ACC ¹							E7H
D8H	CCON ¹	CMOD	CCAPM0	CCAPM1	CCAPM2	CCAPM3	CCAPM4	DFH
D0H	PSW ¹					SPCR		D7H
C8H	T2CON ¹	T2MOD	RCAP2L	RCAP2H	TL2	TH2		CFH
C0H	WDTC ¹							C7H
B8H	IP ¹	SADEN						BFH
B0H	P3 ¹	SFCF	SFCM	SFAL	SFAH	SFDT	SFST	IPH
A8H	IE ¹	SADDR	SPSR				XICON	AFH
A0H	P2 ¹		AUXR1			P4		A7H
98H	SCON ¹	SBUF						9FH
90H	P1 ¹							97H
88H	TCON ¹	TMOD	TL0	TL1	TH0	TH1	AUXR	8FH
80H	P0 ¹	SP	DPL	DPH		WDTD	SPDR	PCON
								87H

1. Bit addressable SFRs

T0-0.0 25093

Table 6: CPU related SFRs

Symbol	Description	Direct Address	Bit Address, Symbol, or Alternative Port Function								Reset Value
			MSB				LSB				
ACC ¹	Accumulator	E0H	ACC[7:0]								00H
B ¹	B Register	F0H	B[7:0]								00H
PSW ¹	Program Status Word	D0H	CY	AC	F0	RS1	RS0	OV	F1	P	00H
SP	Stack Pointer	81H	SP[7:0]								07H
DPL	Data Pointer Low	82H	DPL[7:0]								00H
DPH	Data Pointer High	83H	DPH[7:0]								00H
IE ¹	Interrupt Enable	A8H	EA	EC	ET2	ES	ET1	EX1	ET0	EX0	00H
IEA ¹	Interrupt Enable A	E8H	-	-	-	-	EBO	-	-	-	xxxx0xxx b
IP ¹	Interrupt Priority Reg	B8H	-	PPC	PT2	PS	PT1	PX1	PT0	PX0	x0000000 b
IPH	Interrupt Priority Reg High	B7H	-	PPCH	PT2H	PSH	PT1H	PX1H	PT0H	PX0H	x0000000 b
IP1 ¹	Interrupt Priority Reg A	F8H	-	-	-	-	PBO	PX3	PX2	-	xxxx0xxx b
IP1H	Interrupt Priority Reg A High	F7H	-	-	-	-	PBOH	PX3H	PX2H	-	xxxx0xxx b
PCON	Power Control	87H	SMOD1	SMOD0	BOF	POF	GF1	GF0	PD	IDL	00010000 b
AUXR	Auxiliary Reg	8EH	-	-	-	-	-	-	EXTRAM	AO	xxxxxxx0 0b
AUXR1	Auxiliary Reg 1	A2H	-	-	-	-	GF2	0	-	DPS	xxxx00x0 b
XICON	External Interrupt Control	AEH	-	EX3	IE3	IT3	0	EX2	IE2	IT2	00H

1. Bit Addressable SFRs

T0-0.0 25093

Table 7: Flash Memory Programming SFRs

Symbol	Description	Direct Address	Bit Address, Symbol, or Alternative Port Function								Reset Value
			MSB				LSB				
SFCF	SuperFlash Configuration	B1H	-	IAPEN	-	-	-	-	SWR	BSEL	x0xxxx00b
SFCM	SuperFlash Command	B2H	FIE	FCM[6:0]							00H
SFAL	SuperFlash Address Low	B3H	SuperFlash Low Order Byte Address Register - A ₇ to A ₀ (SFAL)								00H
SFAH	SuperFlash Address High	B4H	SuperFlash High Order Byte Address Register - A ₁₅ to A ₈ (SFAH)								00H
SFDT	SuperFlash Data	B5H	SuperFlash Data Register								00H
SFST	SuperFlash Status	B6H	SB1 _i	SB2 _i	SB3 _i	-	EDC _i	FLASH_BUSY	-	-	000x00xxb

T0-0.0 25093

Table 8: Watchdog Timer SFRs

Symbol	Description	Direct Address	Bit Address, Symbol, or Alternative Port Function								Reset Value
			MSB				LSB				
WDTC ₁	Watchdog Timer Control	C0H	-	-	-	WDOUT	WDRE	WDTS	WDT	SWDT	xxx00x00b
WDTD	Watchdog Timer Data/Reload	85H	Watchdog Timer Data/Reload								00H

T0-0.0 25093

1. Bit Addressable SFRs

Table 9: Timer/Counters SFRs

Symbol	Description	Direct Address	Bit Address, Symbol, or Alternative Port Function								Reset Value
			MSB				LSB				
TMOD	Timer/Counter Mode Control	89H	Timer 1				Timer 0				00H
			GATE	C/T#	M1	M0	GATE	C/T#	M1	M0	
TCON ¹	Timer/Counter Control	88H	TF1	TR1	TF0	TR0	IE1	IT1	IE0	IT0	00H
TH0	Timer 0 MSB	8CH	TH0[7:0]								00H
TL0	Timer 0 LSB	8AH	TL0[7:0]								00H
TH1	Timer 1 MSB	8DH	TH1[7:0]								00H
TL1	Timer 1 LSB	8BH	TL1[7:0]								00H
T2CON ¹	Timer / Counter 2 Control	C8H	TF2	EXF2	RCLK	TCLK	EXEN2	TR2	C/T2#	CP/RL2#	00H
T2MOD	Timer2 Mode Control	C9H	-	-	-	-	-	-	T2OE	DCEN	xxxxxx00b
TH2	Timer 2 MSB	CDH	TH2[7:0]								00H
TL2	Timer 2 LSB	CCH	TL2[7:0]								00H
RCAP2H	Timer 2 Capture MSB	CBH	RCAP2H[7:0]								00H
RCAP2L	Timer 2 Capture LSB	CAH	RCAP2L[7:0]								00H

T0-0.0 25093

1. Bit Addressable SFRs

Table 10: Interface SFRs

Symbol	Description	Direct Address	Bit Address, Symbol, or Alternative Port Function								RESET Value
			MSB				LSB				
SBUF	Serial Data Buffer	99H	SBUF[7:0]								Indeterminate
SCON ¹	Serial Port Control	98H	SM0/FE	SM1	SM2	REN	TB8	RB8	TI	RI	00H
SADDR	Slave Address	A9H	SADDR[7:0]								00H
SADEN	Slave Address Mask	B9H	SADEN[7:0]								00H
SPCR	SPI Control Register	D5H	SPIE	SPE	DOR D	MST R	CPO L	CPH A	SPR 1	SPR 0	04H
SPSR	SPI Status Register	AAH	SPIF	WCOL							00H
SPDR	SPI Data Register	86H	SPDR[7:0]								00H
P0 ¹	Port 0	80H	P0[7:0]								FFH
P1 ¹	Port 1	90H	-	-	-	-	-	-	T2EX	T2	FFH
P2 ¹	Port 2	A0H	P2[7:0]								FFH
P3 ¹	Port 3	B0H	RD#	WR#	T1	T0	INT1#	INT0#	TXD	RXD	FFH
P4 ²	Port 4	A5H	1	1	1	1	P4.3	P4.2	P4.1	P4.0	FFH

T0-0.0 25093

1. Bit Addressable SFRs
2. P4 is similar to P1 and P3 ports

Table 11: PCA SFRs

Symbol	Description	Direct Address	Bit Address, Symbol, or Alternative Port Function								RESET Value
			MSB				LSB				
CH CL	PCA Timer/Counter	F9H E9H	CH[7:0] CL[7:0]								00H 00H
CCON ¹	PCA Timer/Counter Control Register	D8H	CF	CR	-	CCF4	CCF3	CCF2	CCF1	CCF0	00x0000 0b
CMOD	PCA Timer/Counter Mode Register	D9H	CIDL	WDTE	-	-	-	CPS1	CPS0	ECF	00xxx000 b
CCAP0H	PCA Module 0 Compare/Capture Registers	FAH	CCAP0H[7:0]								00H
CCAP0L		EAH	CCAP0L[7:0]								00H
CCAP1H	PCA Module 1 Compare/Capture Registers	FBH	CCAP1H[7:0]								00H
CCAP1L		EBH	CCAP1L[7:0]								00H
CCAP2H	PCA Module 2 Compare/Capture Registers	FCH	CCAP2H[7:0]								00H
CCAP2L		ECH	CCAP2L[7:0]								00H
CCAP3H	PCA Module 3 Compare/Capture Registers	FDH	CCAP3H[7:0]								00H
CCAP3L		EDH	CCAP3L[7:0]								00H
CCAP4H	PCA Module 4 Compare/Capture Registers	FEH	CCAP4H[7:0]								00H
CCAP4L		EEH	CCAP4L[7:0]								00H
CCAPM0	PCA Compare/Capture Module Mode Registers	DAH	-	ECOM0	CAPP0	CAPN0	MAT0	TOG0	PWM0	ECCF0	x000000 0b
CCAPM1		DBH	-	ECOM1	CAPP1	CAPN1	MAT1	TOG1	PWM1	ECCF1	x000000 0b
CCAPM2		DCH	-	ECOM2	CAPP2	CAPN2	MAT2	TOG2	PWM2	ECCF2	x000000 0b
CCAPM3		DDH	-	ECOM3	CAPP3	CAPN3	MAT3	TOG3	PWM3	ECCF3	x000000 0b
CCAPM4		DEH	-	ECOM4	CAPP4	CAPN4	MAT4	TOG4	PWM4	ECCF4	x000000 0b

1. Bit Addressable SFRs

T0-0.0 25093

SuperFlash Configuration Register (SFCF)

Location	7	6	5	4	3	2	1	0	Reset Value
B1H	-	IAPEN	-	-	-	-	SWR	BSEL	x0xxxx00b

Symbol Function

- IAPEN** Enable IAP operation
 0: IAP commands are disabled
 1: IAP commands are enabled
- SWR** Software Reset
 See Section , “Software Reset”
- BSEL** Program memory block switching bit
 See Figure 6 and Table 3

SuperFlash Command Register (SFCM)

Location	7	6	5	4	3	2	1	0	Reset Value
B2H	FIE	FCM6	FCM5	FCM4	FCM3	FCM2	FCM1	FCM0	00H

Symbol Function

- FIE** Flash Interrupt Enable.
 0: INT1# is not reassigned.
 1: INT1# is re-assigned to signal IAP operation completion.
 External INT1# interrupts are ignored.
- FCM[6:0]** Flash operation command
- 000_0001b Chip-Erase
 - 000_1011b Sector-Erase
 - 000_1101b Block-Erase
 - 000_1100b Byte-Verify¹
 - 000_1110b Byte-Program
 - 000_1111b Prog-SB1
 - 000_0011b Prog-SB2
 - 000_0101b Prog-SB3
 - 000_1001b Prog-SC0
 - 000_1000b Enable-Clock-Double
- All other combinations are not implemented, and reserved for future use.
1. Byte-Verify has a single machine cycle latency and will not generate any INT1# interrupt regardless of FIE.

SuperFlash Address Registers (SFAL)

Location	7	6	5	4	3	2	1	0	Reset Value
B3H	SuperFlash Low Order Byte Address Register								00H

Symbol Function

- SFAL** Mailbox register for interfacing with flash memory block. (Low order address register).

SuperFlash Address Registers (SFAH)

Location	7	6	5	4	3	2	1	0	Reset Value
B4H	SuperFlash High Order Byte Address Register								00H

Symbol Function

SFAH Mailbox register for interfacing with flash memory block. (High order address register).

SuperFlash Data Register (SFDT)

Location	7	6	5	4	3	2	1	0	Reset Value
B5H	SuperFlash Data Register								00H

Symbol Function

SFDT Mailbox register for interfacing with flash memory block. (Data register).

SuperFlash Status Register (SFST) (Read Only Register)

Location	7	6	5	4	3	2	1	0	Reset Value
B6H	SB1 _i	SB2 _i	SB3 _i	-	EDC _i	FLASH_BU SY	-	-	xxxx0xxb

Symbol Function

SB1_i Security Bit 1 status (inverse of SB1 bit)

SB2_i Security Bit 2 status (inverse of SB2 bit)

SB3_i Security Bit 3 status (inverse of SB3 bit)

Please refer to Table 25 for security lock options.

EDC_i Double Clock Status

0: 12 clocks per machine cycle

1: 6 clocks per machine cycle

FLASH_BUSY Flash operation completion polling bit.

0: Device has fully completed the last IAP command.

1: Device is busy with flash operation.

Interrupt Enable (IE)

Location	7	6	5	4	3	2	1	0	Reset Value
A8H	EA	EC	ET2	ES	ET1	EX1	ET0	EX0	00H

Symbol Function

- EA Global Interrupt Enable.
0 = Disable
1 = Enable
- EC PCA Interrupt Enable.
- ET2 Timer 2 Interrupt Enable.
- ES Serial Interrupt Enable.
- ET1 Timer 1 Interrupt Enable.
- EX1 External 1 Interrupt Enable.
- ET0 Timer 0 Interrupt Enable.
- EX0 External 0 Interrupt Enable.

Interrupt Enable A (IEA)

Location	7	6	5	4	3	2	1	0	Reset Value
E8H	-	-	-	-	EBO	-	-	-	xxxx0xxxh

Symbol Function

- EBO Brown-out Interrupt Enable.
1 = Enable the interrupt
0 = Disable the interrupt

Interrupt Priority (IP)

Location	7	6	5	4	3	2	1	0	Reset Value
B8H	-	PPC	PT2	PS	PT1	PX1	PT0	PX0	x0000000b

Symbol Function

PPC	PCA interrupt priority bit
PT2	Timer 2 interrupt priority bit
PS	Serial Port interrupt priority bit
PT1	Timer 1 interrupt priority bit
PX1	External interrupt 1 priority bit
PT0	Timer 0 interrupt priority bit
PX0	External interrupt 0 priority bit

Interrupt Priority High (IPH)

Location	7	6	5	4	3	2	1	0	Reset Value
B7H	-	PPCH	PT2H	PSH	PT1H	PX1H	PT0H	PX0H	x0000000b

Symbol Function

PPCH	PCA interrupt priority bit high
PT2H	Timer 2 interrupt priority bit high
PSH	Serial Port interrupt priority bit high
PT1H	Timer 1 interrupt priority bit high
PX1H	External interrupt 1 priority bit high
PT0H	Timer 0 interrupt priority bit high
PX0H	External interrupt 0 priority bit high

Interrupt Priority 1 (IP1)

Location	7	6	5	4	3	2	1	0	Reset Value
F8H	1	-	-	1	PBO	PX3	PX2	1	1xx10001b

Symbol Function

PBO	Brown-out interrupt priority bit
PX2	External Interrupt 2 priority bit
PX3	External Interrupt 3 priority bit

Interrupt Priority 1 High (IP1H)

Location	7	6	5	4	3	2	1	0	Reset Value
F7H	1	-	-	1	PBOH	PX3H	PX2H	1	1xx10001b

Symbol Function

PBOH	Brown-out Interrupt priority bit high
PX2H	External Interrupt 2 priority bit high
PX3H	External Interrupt 3 priority bit high

Auxiliary Register (AUXR)

Location	7	6	5	4	3	2	1	0	Reset Value
8EH	-	-	-	-	-	-	EXTRA M	AO	xxxxxx00b

Symbol Function

EXTRAM Internal/External RAM access

0: Internal Expanded RAM access within range of 00H to 2FFH using MOVX @Ri / @DPTR. Beyond 300H, the MCU always accesses external data memory.

For details, refer to Section , “Expanded Data RAM Addressing” .

1: External data memory access.

AO Disable/Enable ALE

0: ALE is emitted at a constant rate of 1/3 the oscillator frequency in 6 clock mode, 1/6 f_{OSC} in 12 clock mode.

1: ALE is active only during a MOVX or MOVC instruction.

Auxiliary Register 1 (AUXR1)

Location	7	6	5	4	3	2	1	0	Reset Value
A2H	-	-	-	-	GF2	0	-	DPS	xxxx00x0b

Symbol Function

GF2 General purpose user-defined flag.

DPS DPTR registers select bit.

0: DPTR0 is selected.

1: DPTR1 is selected.

Watchdog Timer Control Register (WDTC)

Location	7	6	5	4	3	2	1	0	Reset Value
C0H	-	-	-	WDOUT	WDRE	WDTS	WDT	SWDT	xxx00000b

Symbol Function

WDOUT Watchdog output enable.

0: Watchdog reset will not be exported on Reset pin.

1: Watchdog reset if enabled by WDRE, will assert Reset pin for 32 clocks.

WDRE Watchdog timer reset enable.

0: Disable watchdog timer reset.

1: Enable watchdog timer reset.

WDTS Watchdog timer reset flag.

0: External hardware reset or power-on reset clears the flag.

Flag can also be cleared by writing a 1.

Flag survives if chip reset happened because of watchdog timer overflow.

1: Hardware sets the flag on watchdog overflow.

WDT Watchdog timer refresh.

0: Hardware resets the bit when refresh is done.

1: Software sets the bit to force a watchdog timer refresh.

SWDT Start watchdog timer.

0: Stop WDT.

1: Start WDT.

Watchdog Timer Data/Reload Register (WDTD)

Location	7	6	5	4	3	2	1	0	Reset Value
85H	Watchdog Timer Data/Reload								00H

Symbol Function

WDTD Initial/Reload value in Watchdog Timer. New value won't be effective until WDT is set.

PCA Timer/Counter Control Register¹ (CCON)

Location	7	6	5	4	3	2	1	0	Reset Value
D8H	CF	CR	-	CCF4	CCF3	CCF2	CCF1	CCF0	00x00000b

1. Bit addressable

Symbol Function

- CF PCA Counter Overflow Flag
Set by hardware when the counter rolls over. CF flags an interrupt if bit ECF in CMOD is set. CF may be set by either hardware or software, but can only be cleared by software.
- CR PCA Counter Run control bit
Set by software to turn the PCA counter on. Must be cleared by software to turn the PCA counter off.
- Not implemented, reserved for future use.
Note: User should not write '1's to reserved bits. The value read from a reserved bit is indeterminate.
- CCF4 PCA Module 4 interrupt flag. Set by hardware when a match or capture occurs. Must be cleared by software.
- CCF3 PCA Module 3 interrupt flag. Set by hardware when a match or capture occurs. Must be cleared by software.
- CCF2 PCA Module 2 interrupt flag. Set by hardware when a match or capture occurs. Must be cleared by software.
- CCF1 PCA Module 1 interrupt flag. Set by hardware when a match or capture occurs. Must be cleared by software.
- CCF0 PCA Module 0 interrupt flag. Set by hardware when a match or capture occurs. Must be cleared by software.

PCA Timer/Counter Mode Register¹ (CMOD)

Location	7	6	5	4	3	2	1	0	Reset Value
D9H	CIDL	WDTE	-	-	-	CPS1	CPS0	ECF	00xxx000b

1. Not bit addressable

Symbol Function

- CIDL** Counter Idle Control:
 0: Programs the PCA Counter to continue functioning during idle mode
 1: Programs the PCA Counter to be gated off during idle
- WDTE** Watchdog Timer Enable:
 0: Disables Watchdog Timer function on PCA module 4
 1: Enables Watchdog Timer function on PCA module 4
- Not implemented, reserved for future use.
Note: User should not write '1's to reserved bits. The value read from a reserved bit is indeterminate.
- CPS1** PCA Count Pulse Select bit 1
- CPS0** PCA Count Pulse Select bit 2

CPS1	CPS0	Selected PCA Input ¹	
0	0	0	Internal clock, $f_{OSC}/6$ in 6 clock mode ($f_{OSC}/12$ in 12 clock mode)
0	1	1	Internal clock, $f_{OSC}/2$ in 6 clock mode ($f_{OSC}/4$ in 12 clock mode)
1	0	2	Timer 0 overflow
1	1	3	External clock at ECI/P1.2 pin
			(max. rate = $f_{OSC}/4$ in 6 clock mode, $f_{OSC}/8$ in 12 clock mode)

1. f_{OSC} = oscillator frequency

- ECF** PCA Enable Counter Overflow interrupt:
 0: Disables the CF bit in CCON
 1: Enables CF bit in CCON to generate an interrupt

PCA Compare/Capture Module Mode Register¹ (CCAPMn)

Location	7	6	5	4	3	2	1	0	Reset Value
DAH	-	ECOM0	CAPP0	CAPN0	MAT0	TOG0	PWM0	ECCF0	00xxx000b
DBH	-	ECOM1	CAPP1	CAPN1	MAT1	TOG1	PWM1	ECCF1	00xxx000b
DCH	-	ECOM2	CAPP2	CAPN2	MAT2	TOG2	PWM2	ECCF2	00xxx000b
DDH	-	ECOM3	CAPP3	CAPN3	MAT3	TOG3	PWM3	ECCF3	00xxx000b
DEH	-	ECOM4	CAPP4	CAPN4	MAT4	TOG4	PWM4	ECCF4	00xxx000b

1. Not bit addressable

Symbol Function

- Not implemented, reserved for future use.
Note: User should not write '1's to reserved bits. The value read from a reserved bit is indeterminate.
- ECOMn Enable Comparator
 0: Disables the comparator function
 1: Enables the comparator function
- CAPPn Capture Positive
 0: Disables positive edge capture on CEX[4:0]
 1: Enables positive edge capture on CEX[4:0]
- CAPNn Capture Negative
 0: Disables negative edge capture on CEX[4:0]
 1: Enables negative edge capture on CEX[4:0]
- MATn Match: Set ECOM[4:0] and MAT[4:0] to implement the software timer mode
 0: Disables software timer mode
 1: A match of the PCA counter with this module's compare/capture register causes the CCFn bit in CCON to be set, flagging an interrupt.
- TOGn Toggle
 0: Disables toggle function
 1: A match of the PCA counter with this module's compare/capture register causes the CEXn pin to toggle.
- PWMn Pulse Width Modulation mode
 0: Disables PWM mode
 1: Enables CEXn pin to be used as a pulse width modulated output
- ECCFn Enable CCF Interrupt
 0: Disables compare/capture flag CCF[4:0] in the CCON register to generate an interrupt request.
 1: Enables compare/capture flag CCF[4:0] in the CCON register to generate an interrupt request.

SPI Control Register (SPCR)

Location	7	6	5	4	3	2	1	0	Reset Value
D5H	SPIE	SPE	DORD	MSTR	CPOL	CPHA	SPR1	SPR0	00H

Symbol Function

SPIE If both SPIE and ES are set to one, SPI interrupts are enabled.

SPE SPI enable bit.
 0: Disables SPI.
 1: Enables SPI and connects SS#, MOSI, MISO, and SCK to pins P1.4, P1.5, P1.6, P1.7.

DORD Data Transmission Order.
 0: MSB first in data transmission.
 1: LSB first in data transmission.

MSTR Master/Slave select.
 0: Selects Slave mode.
 1: Selects Master mode.

CPOL Clock Polarity
 0: SCK is low when idle (Active High).
 1: SCK is high when idle (Active Low).

CPHA Clock Phase control bit. The CPHA bit with the CPOL bit control the clock and data relationship between master and slave. See Figures 21 and 22.
 0: Shift triggered on the leading edge of the clock.
 1: Shift triggered on the trailing edge of the clock.

SPR1, SPR0 SPI Clock Rate Select bits. These two bits control the SCK rate of the device configured as master. SPR1 and SPR0 have no effect on the slave. The relationship between SCK and the oscillator frequency, f_{OSC} , is as follows:

SPR1	SPR0	SCK = f_{OSC} divided by
0	0	4
0	1	16
1	0	64
1	1	128

SPI Status Register (SPSR)

Location	7	6	5	4	3	2	1	0	Reset Value
AAH	SPIF	WCOL	-	-	-	-	-	-	00xxxxxb

Symbol Function

SPIF SPI Interrupt Flag.
 Upon completion of data transfer, this bit is set to 1.
 If SPIE =1 and ES =1, an interrupt is then generated.
 This bit is cleared by software.

WCOL Write Collision Flag.
 Set if the SPI data register is written to during data transfer.
 This bit is cleared by software.

SPI Data Register (SPDR)

Location	7	6	5	4	3	2	1	0	Reset Value
86H	SPDR[7:0]								00H

Power Control Register (PCON)

Location	7	6	5	4	3	2	1	0	Reset Value
87H	SMOD1	SMOD0	BOF	POF	GF1	GF0	PD	IDL	00010000b

Symbol Function

- SMOD1 Double Baud rate bit. If SMOD1 = 1, Timer 1 is used to generate the baud rate, and the serial port is used in modes 1, 2, and 3.
- SMOD0 FE/SM0 Selection bit.
 0: SCON[7] = SM0
 1: SCON[7] = FE,
- BOF Brown-out detection status bit, this bit will not be affected by any other reset. BOF should be cleared by software. Power-on reset will also clear the BOF bit.
 0: No brown-out.
 1: Brown-out occurred
- POF Power-on reset status bit, this bit will not be affected by any other reset. POF should be cleared by software.
 0: No Power-on reset.
 1: Power-on reset occurred
- GF1 General-purpose flag bit.
- GF0 General-purpose flag bit.
- PD Power-down bit, this bit is cleared by hardware after exiting from power-down mode.
 0: Power-down mode is not activated.
 1: Activates Power-down mode.
- IDL Idle mode bit, this bit is cleared by hardware after exiting from idle mode.
 0: Idle mode is not activated.
 1: Activates idle mode.

Serial Port Control Register (SCON)

Location	7	6	5	4	3	2	1	0	Reset Value
98H	SM0/FE	SM1	SM2	REN	TB8	RB8	TI	RI	00000000b

Symbol Function

- FE** Set SMOD0 = 1 to access FE bit.
 0: No framing error
 1: Framing Error. Set by receiver when an invalid stop bit is detected. This bit needs to be cleared by software.
- SM0** SMOD0 = 0 to access SM0 bit.
 Serial Port Mode Bit 0
- SM1** Serial Port Mode Bit 1

SM0	SM1	Mode	Description	Baud Rate ¹
0	0	0	Shift Register	$f_{osc}/6$ (6 clock mode) or $f_{osc}/12$ (12 clock mode)
0	1	1	8-bit UART	Variable
1	0	2	9-bit UART	$f_{osc}/32$ or $f_{osc}/16$ (6 clock mode) or $f_{osc}/64$ or $f_{osc}/32$ (12 clock mode)
1	1	3	9-bit UART	Variable

1. f_{osc} = oscillator frequency

- SM2** Enables the Automatic Address Recognition feature in Modes 2 or 3. If SM2 = 1 then RI will not be set unless the received 9th data bit (RB8) is 1, indicating an address, and the received byte is a given or broadcast address. In Mode 1, if SM2 = 1 then RI will not be activated unless a valid stop bit was received. In Mode 0, SM2 should be 0.
- REN** Enables serial reception.
 0: to disable reception.
 1: to enable reception.
- TB8** The 9th data bit that will be transmitted in Modes 2 and 3. Set or clear by software as desired.
- RB8** In Modes 2 and 3, the 9th data bit that was received. In Mode 1, if SM2 = 0, RB8 is the stop bit that was received. In Mode 0, RB8 is not used.
- TI** Transmit interrupt flag. Set by hardware at the end of the 8th bit time in Mode 0, or at the beginning of the stop bit in the other modes, in any serial transmission, Must be cleared by software.
- RI** Receive interrupt flag. Set by hardware at the end of the 8th bit time in Mode 0, or halfway through the stop bit time in the other modes, in any serial reception (except see SM2). Must be cleared by software.

Timer/Counter 2 Control Register (T2CON)

Location	7	6	5	4	3	2	1	0	Reset Value
C8H	TF2	EXF2	RCLK	TCLK	EXEN2	TR2	C/T2#	CP/ RL2#	00H

Symbol Function

- TF2** Timer 2 overflow flag set by a Timer 2 overflow and must be cleared by software. TF2 will not be set when either RCLK or TCLK = 1.
- EXF2** Timer 2 external flag set when either a capture or reload is caused by a negative transition on T2EX and EXEN2 = 1. When Timer 2 interrupt is enabled, EXF2 = 1 will cause the CPU to vector to the Timer 2 interrupt routine. EXF2 must be cleared by software. EXF2 does not cause an interrupt in up/down counter mode (DCEN = 1).
- RCLK** Receive clock flag. When set, causes the serial port to use Timer 2 overflow pulses for its receive clock in modes 1 and 3. RCLK = 0 causes Timer 1 overflow to be used for the receive clock.
- TCLK** Transmit clock flag. When set, causes the serial port to use Timer 2 overflow pulses for its transmit clock in modes 1 and 3. TCLK = 0 causes Timer 1 overflow to be used for the transmit clock.
- EXEN2** Timer 2 external enable flag. When set, allows a capture or reload to occur as a result of a negative transition on T2EX if Timer 2 is not being used to clock the serial port. EXEN2 = 0 causes Timer 2 to ignore events at T2EX.
- TR2** Start/stop control for Timer 2. A logic 1 starts the timer.
- C/T2#** Timer or counter select (Timer 2)
 0: Internal timer (OSC/6 in 6 clock mode, OSC/12 in 12 clock mode)
 1: External event counter (falling edge triggered)
- CP/RL2#** Capture/Reload flag. When set, captures will occur on negative transitions at T2EX if EXEN2 = 1. When cleared, auto-reloads will occur either with Timer 2 overflows or negative transitions at T2EX when EXEN2 = 1. When either RCLK = 1 or TCLK = 1, this bit is ignored and the timer is forced to auto-reload on Timer 2 overflow.

Timer/Counter 2 Mode Control (T2MOD)

Location	7	6	5	4	3	2	1	0	Reset Value
C9H	-	-	-	-	-	-	T2OE	DCEN	xxxxxx00b

Symbol Function

- Not implemented, reserved for future use.
Note: User should not write '1's to reserved bits. The value read from a reserved bit is indeterminate.
- T2OE** Timer 2 Output Enable bit.
- DCEN** Down Count Enable bit. When set, this allows Timer 2 to be configured as an up/down counter.

External Interrupt Control (XICON)

Location	7	6	5	4	3	2	1	0	Reset Value
AEH	-	EX3	IE3	IT3	0	EX2	IE2	IT2	00H

Symbol Function

- EX2 External Interrupt 2
Enable bit if set
- IE2 Interrupt Enable
If IT2=1, IE2 is set/cleared automatically by hardware when interrupt is detected/serviced.
- IT2 External Interrupt 2 is falling-edge/low-level triggered when this bit is cleared by software.
- EX3 External Interrupt 3
Enable bit if set
- IE3 Interrupt Enable
If IT3=1, IE3 is set/cleared automatically by hardware when interrupt is detected/serviced.
- IT3 External Interrupt3 is falling-edge/low-level triggered when this bit is cleared by software.

Flash Memory Programming

The device internal flash memory can be programmed or erased using In-Application Programming (IAP) mode

Product Identification

The Read-ID command accesses the Signature Bytes that identify the device and the manufacturer as SST. External programmers primarily use these Signature Bytes in the selection of programming algorithms.

Table 12: Product Identification

	Address	Data
Manufacturer's ID	30H	BFH
Device ID		
SST89E516RD2/RD	31H	93H
SST89V516RD2/RD	31H	92H

T0-0.0 25093

In-Application Programming Mode

The device offers either 72 KByte of in-application programmable flash memory. During in-application programming, the CPU of the microcontroller enters IAP mode. The two blocks of flash memory allow the CPU to execute user code from one block, while the other is being erased or reprogrammed concurrently. The CPU may also fetch code from an external memory while all internal flash is being reprogrammed. The mailbox registers (SFST, SFCM, SFAL, SFAH, SFDT and SFCF) located in the special function register (SFR), control and monitor the device's erase and program process.

Table 14 outline the commands and their associated mailbox register settings.

In-Application Programming Mode Clock Source

During IAP mode, both the CPU core and the flash controller unit are driven off the external clock. However, an internal oscillator will provide timing references for Program and Erase operations. The internal oscillator is only turned on when required, and is turned off as soon as the flash operation is completed.

Memory Bank Selection for In-Application Programming Mode

With the addressing range limited to 16 bit, only 64 KByte of program address space is "visible" at any one time. As shown in Table 13, the bank selection (the configuration of EA# and SFCF[1:0]), allows Block 1 memory to be overlaid on the lowest 8 KByte of Block 0 memory, making Block 1 reachable. The same concept is employed to allow both Block 0 and Block 1 flash to be accessible to IAP operations. Code from a block that is not visible may not be used as a source to program another address. However, a block that is not "visible" may be programmed by code from the other block through mailbox registers.

The device allows IAP code in one block of memory to program the other block of memory, but may not program any location in the same block. If an IAP operation originates physically from Block 0, the target of this operation is implicitly defined to be in Block 1. If the IAP operation originates physically from

Block 1, then the target address is implicitly defined to be in Block 0. If the IAP operation originates from external program space, then, the target will depend on the address and the state of bank selection.

IAP Enable Bit

The IAP enable bit, SFCF[6], enables in-application programming mode. Until this bit is set, all flash programming IAP commands will be ignored.

Table 13: IAP Address Resolution

EA#	SFCF[1:0]	Address of IAP Inst.	Target Address	Block Being Programmed
1	00	>= 2000H (Block 0)	>= 2000H (Block 0)	None ¹
1	00	>= 2000H (Block 0)	< 2000H (Block 1)	Block 1
1	00	< 2000H (Block 1)	Any (Block 0)	Block 0
1	01, 10, 11	Any (Block 0)	>= 2000H (Block 0)	None ¹
1	01, 10, 11	Any (Block 0)	< 2000H (Block 1)	Block 1
0	00	From external	>= 2000H (Block 0)	Block 0
0	00	From external	< 2000H (Block 1)	Block 1
0	01, 10, 11	From external	Any (Block 0)	Block 0

TO-0.0 25093

1. No operation is performed because code from one block may not program the same originating block

In-Application Programming Mode Commands

All of the following commands can only be initiated in the IAP mode. In all situations, writing the control byte to the SFCM register will initiate all of the operations. All commands will not be enabled if the security locks are enabled on the selected memory block.

The Program command is for programming new data into the memory array. The portion of the memory array to be programmed should be in the erased state, FFH. If the memory is not erased, it should first be erased with an appropriate Erase command. **Warning: Do not attempt to write (program or erase) to a block that the code is currently fetching from. This will cause unpredictable program behavior and may corrupt program data.**

Chip-Erase

The Chip-Erase command erases all bytes in both memory blocks. This command is only allowed when EA#=0 (external memory execution). Additionally this command is not permitted when the device is in level 4 locking. In all other instances, this command ignores the Security Lock status and will erase the security lock bits and re-map bits.

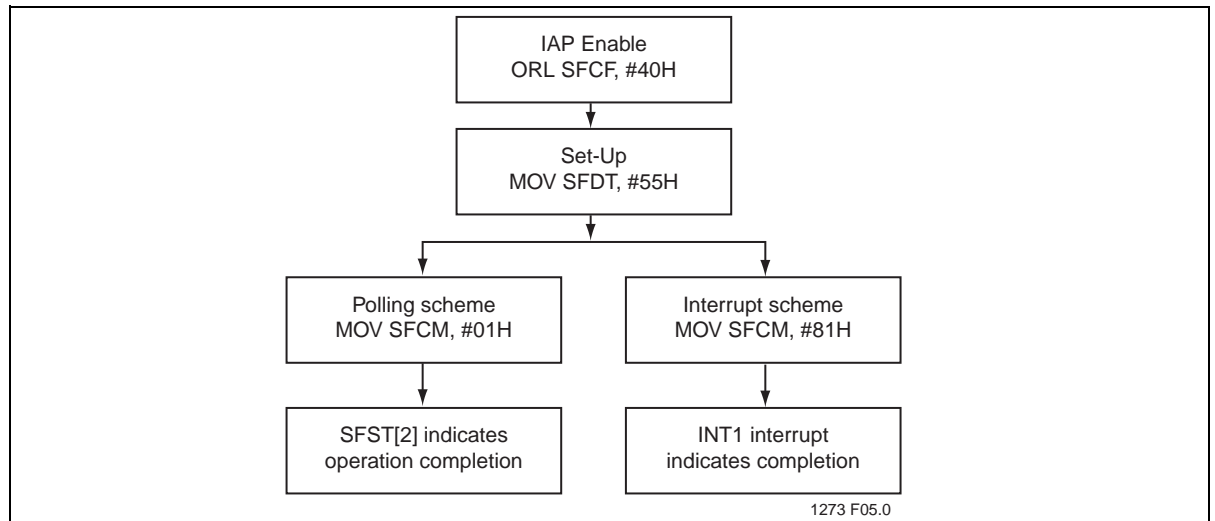

Figure 9: Chip Erase

Block-Erase

The Block-Erase command erases all bytes in one of two memory blocks (Block 0 or Block 1). The selection of the memory block to be erased is determined by the SFCF[1:0]. The Block-Erase command sequence for SST89x516RDx is as follows:

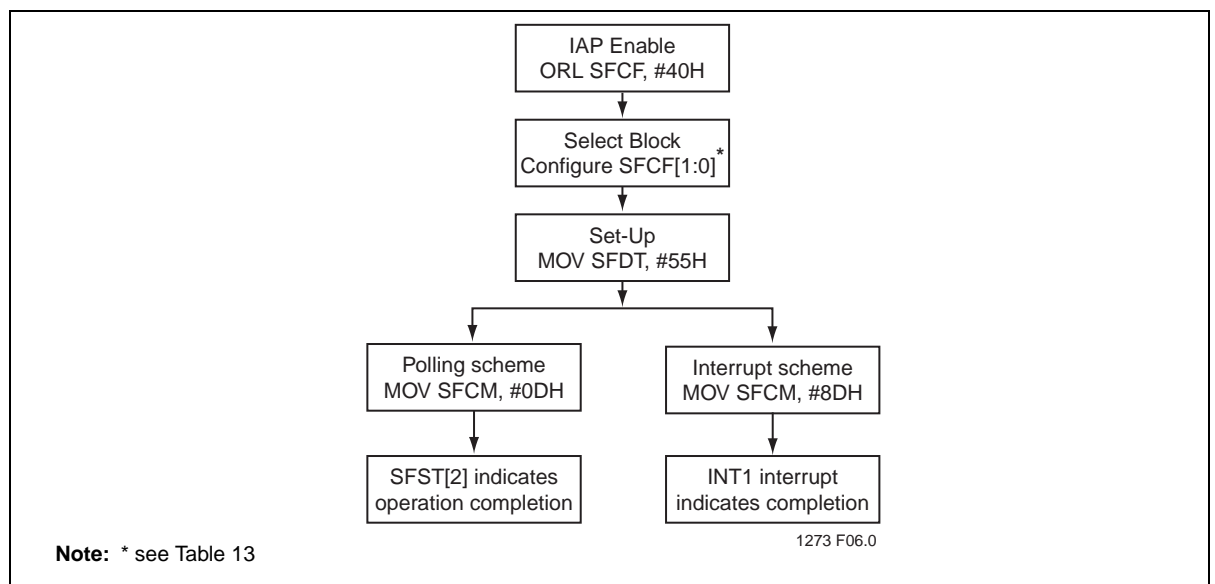

Figure 10:Block Erase

Sector-Erase

The Sector-Erase command erases all of the bytes in a sector. The sector size for the flash memory blocks is 128 Bytes. The selection of the sector to be erased is determined by the contents of SFAH and SFAL.

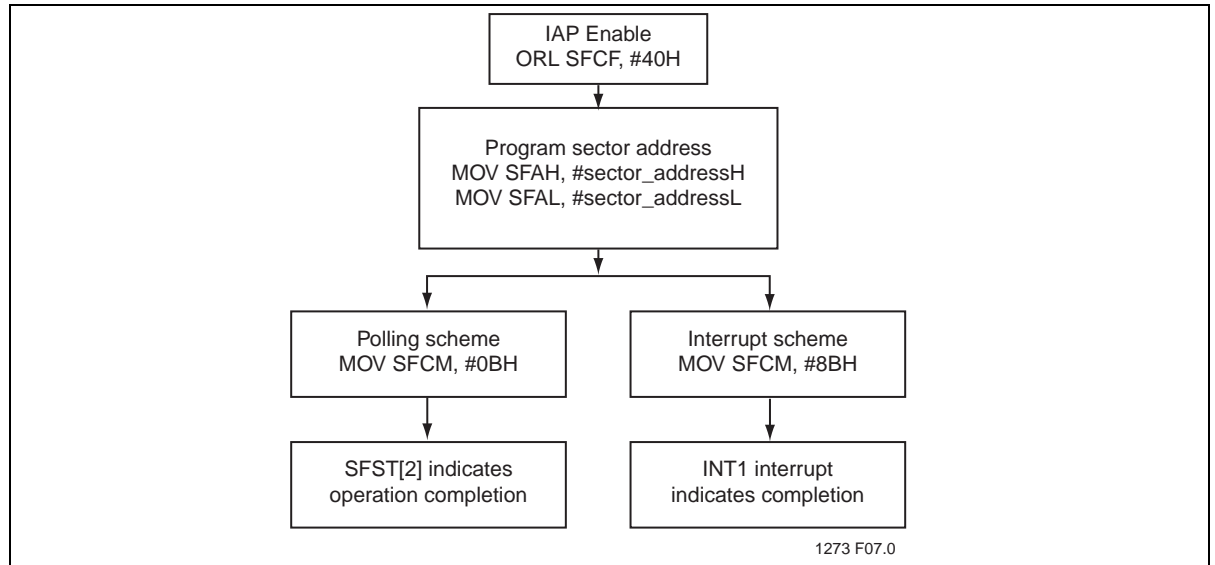

Figure 11:Sector Erase

Byte-Program

The Byte-Program command programs data into a single byte. The address is determined by the contents of SFAH and SFAL. The data byte is in SFDT.

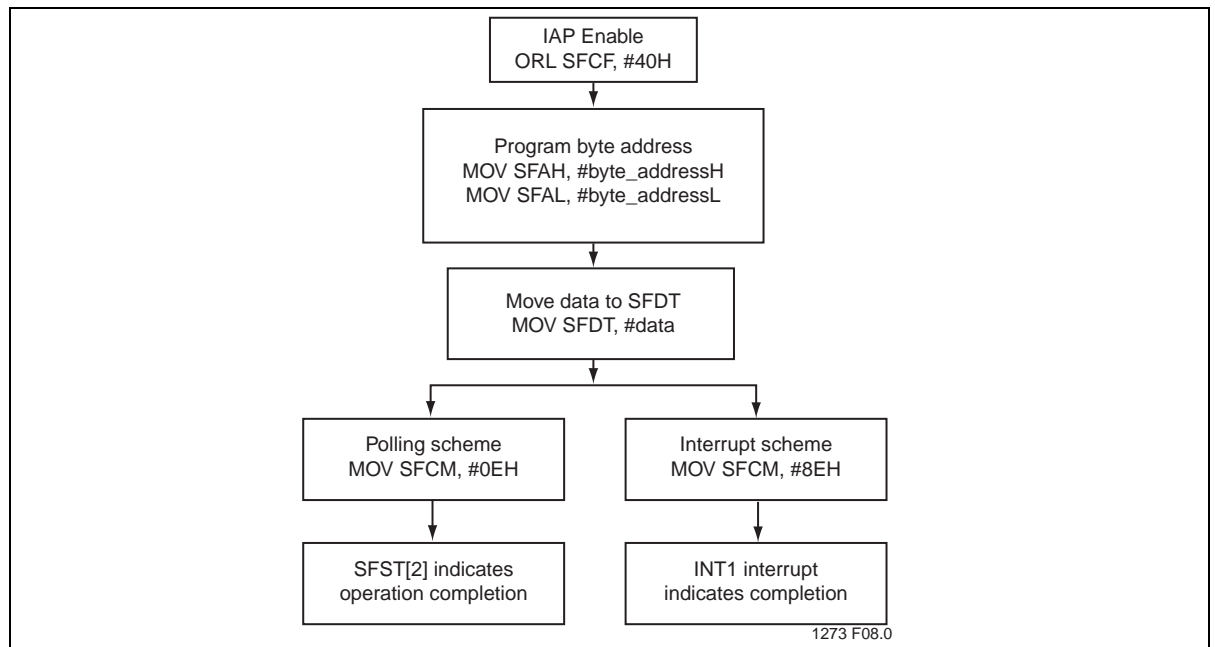

Figure 12:Byte Program

Byte-Verify

The Byte-Verify command allows the user to verify that the device has correctly performed an Erase or Program command. Byte-Verify command returns the data byte in SFDT if the command is successful. The user is required to check that the previous flash operation has fully completed before issuing a Byte-Verify. Byte-Verify command execution time is short enough that there is no need to poll for command completion and no interrupt is generated.

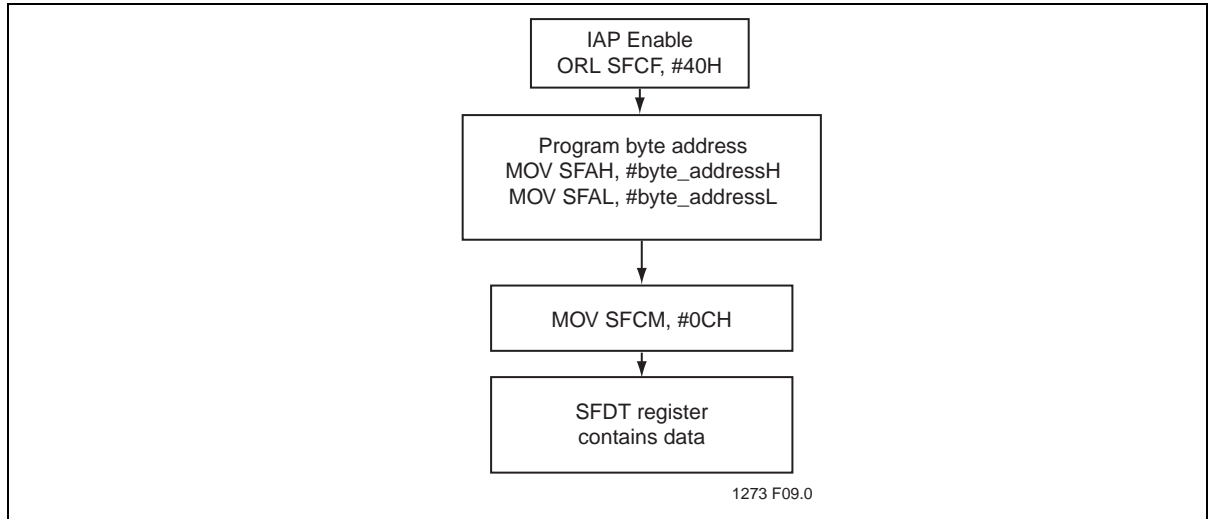

Figure 13:Byte Verify

Prog-SB3, Prog-SB2, Prog-SB1

Prog-SB3, Prog-SB2, Prog-SB1 commands are used to program the security bits (see Table 25). Completion of any of these commands, the security options will be updated immediately.

Security bits previously in un-programmed state can be programmed by these commands. Prog-SB3, Prog-SB2 and Prog-SB1 commands should only reside in Block 1 or external code memory.

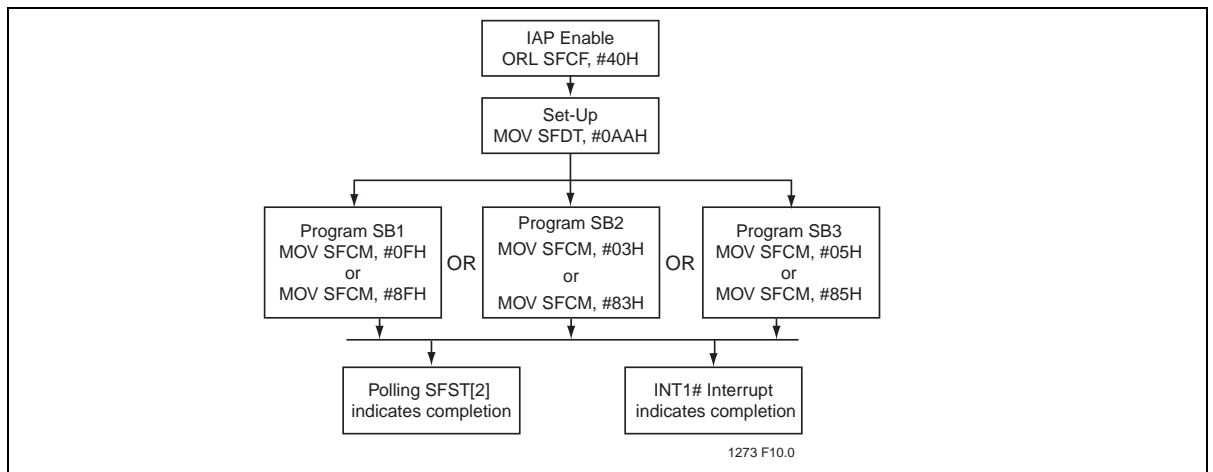

Figure 14:Prog-SB3, Prog-SB2, Prog-SB1

Prog-SC0

Prog-SC0 command is used to program the SC0 bit. This command only changes the SC0 bit and has no effect on BSEL bit until after a reset cycle.

SC0 bit previously in un-programmed state can be programmed by this command. The Prog-SC0 command should reside only in Block 1 or external code memory.

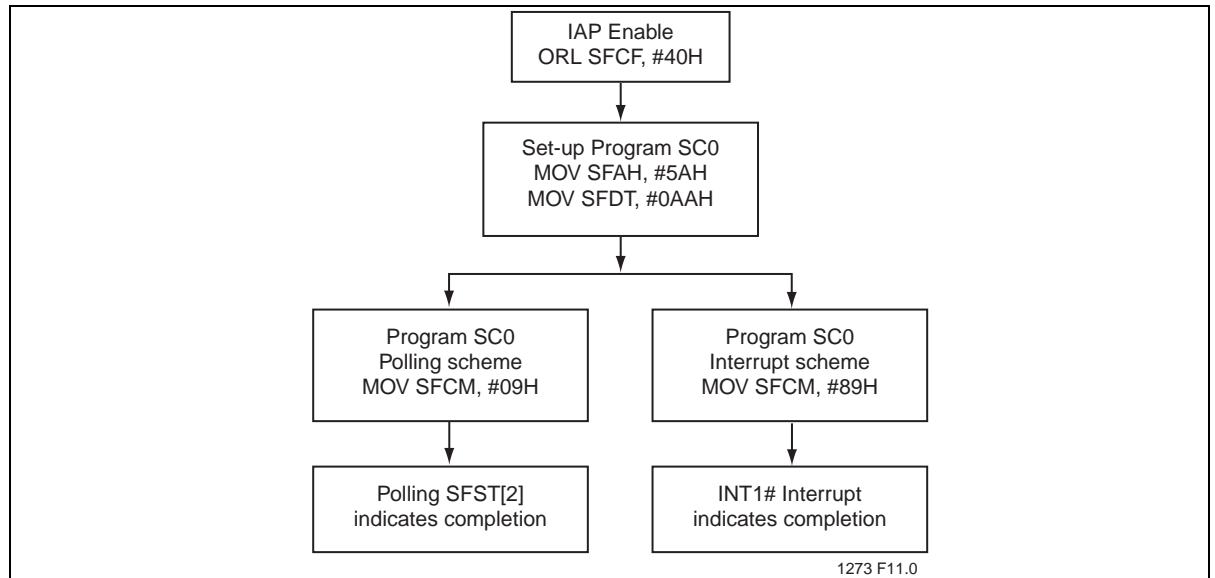

Figure 15:Prog-SC0

Enable-Clock-Double

Enable-Clock-Double command is used to make the MCU run at 6 clocks per machine cycle. The standard (default) is 12 clocks per machine cycle (i.e. clock double command disabled).

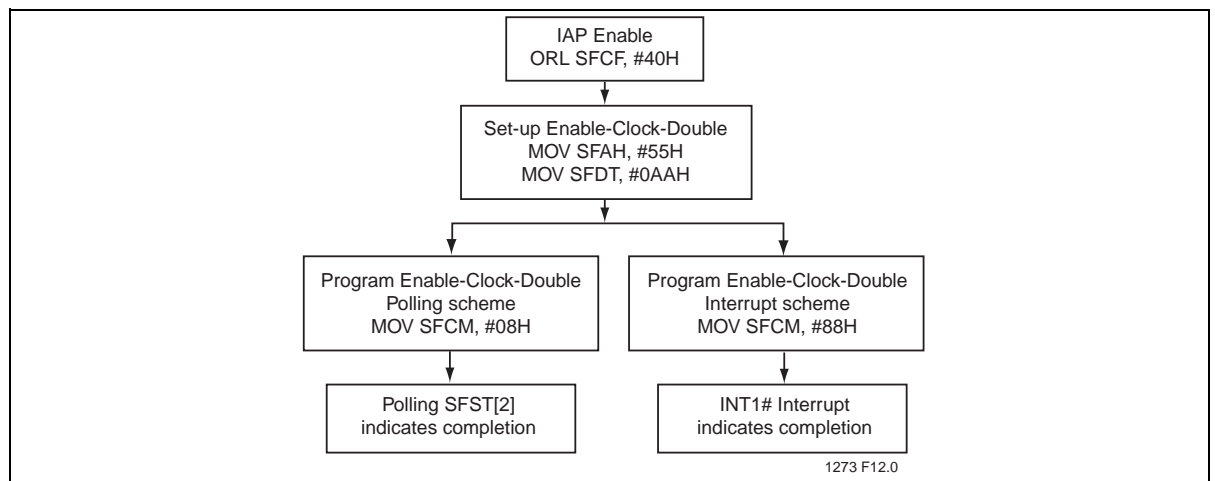

Figure 16:Enable-Clock-Double

There are no IAP counterparts for the external host commands Select-Block0 and Select-Block1.

Polling

A command that uses the polling method to detect flash operation completion should poll on the FLASH_BUSY bit (SFST[2]). When FLASH_BUSY de-asserts (logic 0), the device is ready for the next operation.

MOVC instruction may also be used for verification of the Programming and Erase operation of the flash memory. MOVC instruction will fail if it is directed at a flash block that is still busy.

Interrupt Termination

If interrupt termination is selected, (SFCM[7] is set), then an interrupt (INT1) will be generated to indicate flash operation completion. Under this condition, the INT1 becomes an internal interrupt source. The INT1# pin can now be used as a general purpose port pin and it cannot be the source of External Interrupt 1 during in-application programming.

In order to use an interrupt to signal flash operation termination. EX1 and EA bits of IE register must be set. The IT1 bit of TCON register must also be set for edge trigger detection.

Table 14: IAP Commands¹

Operation	SFCM [6:0] ²	SFDT [7:0]	SFAH [7:0]	SFAL [7:0]
Chip-Erase ³	01H	55H	X ⁴	X
Block-Erase ⁵	0DH	55H	AH	X
Sector-Erase ⁵	0BH	X	AH ⁶	AL ⁷
Byte-Program ⁵	0EH	DI ⁸	AH	AL
Byte-Verify (Read) ⁵	0CH	DO ⁸	AH	AL
Prog-SB1 ⁹	0FH	AAH	X	X
Prog-SB2 ⁹	03H	AAH	X	X
Prog-SB3 ⁹	05H	AAH	X	X
Prog-SC0 ⁹	09H	AAH	5AH	X
Enable-Clock-Double ⁹	08H	AAH	55H	X

TO-0.0 25093

- SFCF[6]=1 enables IAP commands; SFCF[6]=0 disables IAP commands.
- Interrupt/Polling enable for flash operation completion
 SFCM[7] = 1: Interrupt enable for flash operation completion
 0: polling enable for flash operation completion
- Chip-Erase only functions in IAP mode when EA#=0 (external memory execution) and device is not in level 4 locking.
- X can be V_{IL} or V_{IH}, but no other value.
- Refer to Table 13 for address resolution
- AH = Address high order byte
- AL = Address low order byte
- DI = Data Input, DO = Data Output, all other values are in hex.
- Instruction must be located in Block 1 or external code memory.

Note: DISIAPL pin in PLCC or TQFP will also disable IAP commands if it is externally pulled low when reset.

Timers/Counters

Timers

The device has three 16-bit registers that can be used as either timers or event counters. The three timers/counters are denoted Timer 0 (T0), Timer 1 (T1), and Timer 2 (T2). Each is designated a pair of 8-bit registers in the SFRs. The pair consists of a most significant (high) byte and least significant (low) byte. The respective registers are TL0, TH0, TL1, TH1, TL2, and TH2.

Timer Set-up

Refer to Table 9 for TMOD, TCON, and T2CON registers regarding timers T0, T1, and T2. The following tables provide TMOD values to be used to set up Timers T0, T1, and T2.

Except for the baud rate generator mode, the values given for T2CON do not include the setting of the TR2 bit. Therefore, bit TR2 must be set separately to turn the timer on.

Table 15: Timer/Counter 0

	Mode	Function	TMOD	
			Internal Control ¹	External Control ²
Used as Timer	0	13-bit Timer	00H	08H
	1	16-bit Timer	01H	09H
	2	8-bit Auto-Reload	02H	0AH
	3	Two 8-bit Timers	03H	0BH
Used as Counter	0	13-bit Timer	04H	0CH
	1	16-bit Timer	05H	0DH
	2	8-bit Auto-Reload	06H	0EH
	3	Two 8-bit Timers	07H	0FH

T0-0.0 25093

1. The Timer is turned ON/OFF by setting/clearing bit TR0 in the software.
2. The Timer is turned ON/OFF by the 1 to 0 transition on INT0# (P3.2) when TR0 = 1 (hardware control).

Table 16: Timer/Counter 1

	Mode	Function	TMOD	
			Internal Control ¹	External Control ²
Used as Timer	0	13-bit Timer	00H	80H
	1	16-bit Timer	10H	90H
	2	8-bit Auto-Reload	20H	A0H
	3	Does not run	30H	B0H
Used as Counter	0	13-bit Timer	40H	C0H
	1	16-bit Timer	50H	D0H
	2	8-bit Auto-Reload	60H	E0H
	3	Not available	-	-

T0-0.0 25093

1. The Timer is turned ON/OFF by setting/clearing bit TR1 in the software.
2. The Timer is turned ON/OFF by the 1 to 0 transition on INT1# (P3.3) when TR1 = 1 (hardware control).

Table 17: Timer/Counter 2

	Mode	T2CON	
		Internal Control ¹	External Control ²
Used as Timer	16-bit Auto-Reload	00H	08H
	16-bit Capture	01H	09H
	Baud rate generator receive and transmit same baud rate	34H	36H
	Receive only	24H	26H
	Transmit only	14H	16H
Used as Counter	16-bit Auto-Reload	02H	0AH
	16-bit Capture	03H	0BH

T0-0.0 25093

1. Capture/Reload occurs only on timer/counter overflow.
2. Capture/Reload occurs on timer/counter overflow and a 1 to 0 transition on T2EX (P1.1) pin except when Timer 2 is used in the baud rate generating mode.

Programmable Clock-Out

A 50% duty cycle clock can be programmed to come out on P1.0. This pin, besides being a regular I/O pin, has two alternate functions. It can be programmed:

1. to input the external clock for Timer/Counter 2, or
2. to output a 50% duty cycle clock ranging from 122 Hz to 8 MHz at a 16 MHz operating frequency (61 Hz to 4 MHz in 12 clock mode).

To configure Timer/Counter 2 as a clock generator, bit C/#T2 (in T2CON) must be cleared and bit T2OE in T2MOD must be set. Bit TR2 (T2CON.2) also must be set to start the timer.

The Clock-Out frequency depends on the oscillator frequency and the reload value of Timer 2 capture registers (RCAP2H, RCAP2L) as shown in this equation:

$$\frac{\text{Oscillator Frequency}}{n \times (65536 - \text{RCAP2H, RCAP2L})}$$

n =2 (in 6 clock mode)
 4 (in 12 clock mode)

Where (RCAP2H, RCAP2L) = the contents of RCAP2H and RCAP2L taken as a 16-bit unsigned integer.

In the Clock-Out mode, Timer 2 roll-overs will not generate an interrupt. This is similar to when it is used as a baud-rate generator. It is possible to use Timer 2 as a baud-rate generator and a clock generator simultaneously. Note, however, that the baud-rate and the Clock-Out frequency will not be the same.

Serial I/O

Full-Duplex, Enhanced UART

The device serial I/O port is a full-duplex port that allows data to be transmitted and received simultaneously in hardware by the transmit and receive registers, respectively, while the software is performing other tasks. The transmit and receive registers are both located in the Serial Data Buffer (SBUF) special function register. Writing to the SBUF register loads the transmit register, and reading from the SBUF register obtains the contents of the receive register.

The UART has four modes of operation which are selected by the Serial Port Mode Specifier (SM0 and SM1) bits of the Serial Port Control (SCON) special function register. In all four modes, transmission is initiated by any instruction that uses the SBUF register as a destination register. Reception is initiated in mode 0 when the Receive Interrupt (RI) flag bit of the Serial Port Control (SCON) SFR is cleared and the Reception Enable/ Disable (REN) bit of the SCON register is set. Reception is initiated in the other modes by the incoming start bit if the REN bit of the SCON register is set.

Framing Error Detection

Framing Error Detection is a feature, which allows the receiving controller to check for valid stop bits in modes 1, 2, or 3. Missing stop bits can be caused by noise in serial lines or from simultaneous transmission by two CPUs.

Framing Error Detection is selected by going to the PCON register and changing SMOD0 = 1 (see Figure 17). If a stop bit is missing, the Framing Error bit (FE) will be set. Software may examine the FE bit after each reception to check for data errors. After the FE bit has been set, it can only be cleared by software. Valid stop bits do not clear FE. When FE is enabled, RI rises on the stop bit, instead of the last data bit (see Figure 18 and Figure 19).

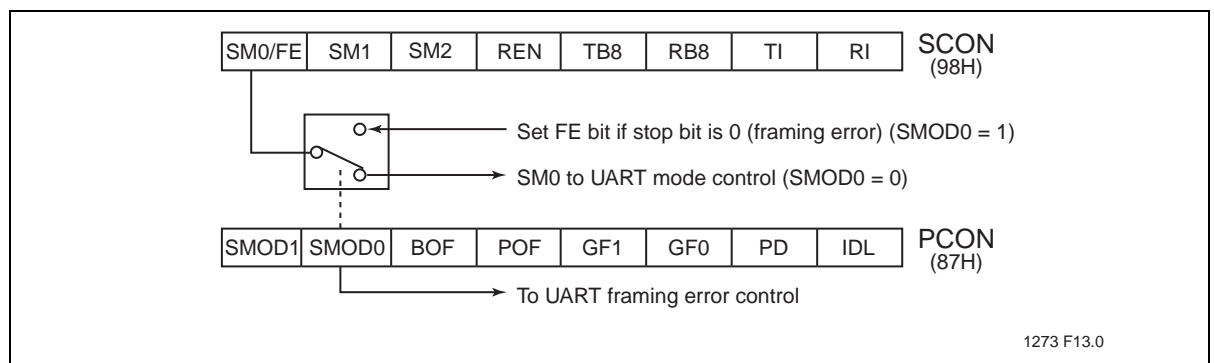

Figure 17: Framing Error Block Diagram

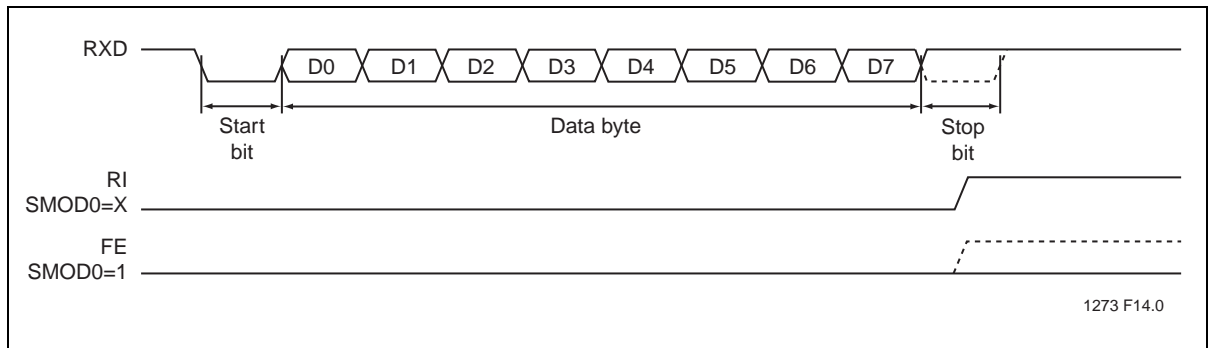

Figure 18:UART Timings in Mode 1

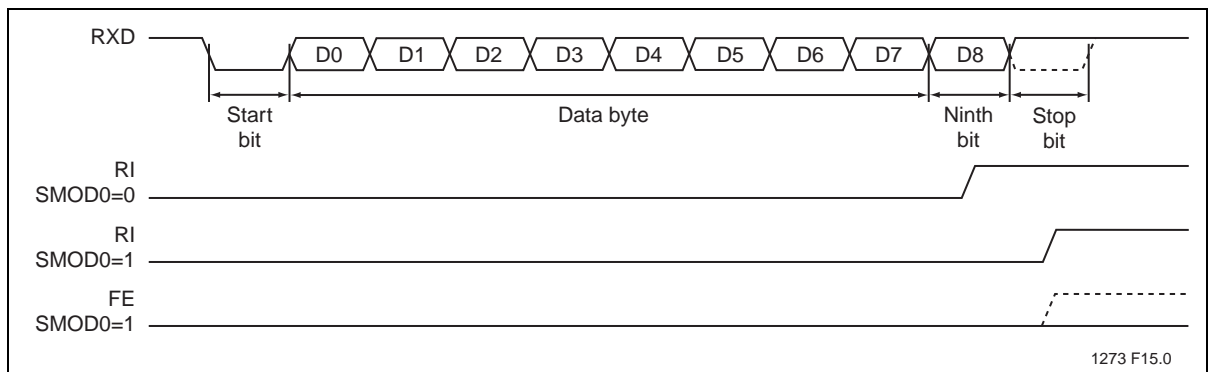

Figure 19:UART Timings in Modes 2 and 3

Automatic Address Recognition

Automatic Address Recognition helps to reduce the MCU time and power required to talk to multiple serial devices. Each device is hooked together sharing the same serial link with its own address. In this configuration, a device is only interrupted when it receives its own address, thus eliminating the software overhead to compare addresses.

This same feature helps to save power because it can be used in conjunction with idle mode to reduce the system's overall power consumption. Since there may be multiple slaves hooked up serial to one master, only one slave would have to be interrupted from idle mode to respond to the master's transmission. Automatic Address Recognition (AAR) allows the other slaves to remain in idle mode while only one is interrupted. By limiting the number of interruptions, the total current draw on the system is reduced.

There are two ways to communicate with slaves: a group of them at once, or all of them at once. To communicate with a group of slaves, the master sends out an address called the given address. To communicate with all the slaves, the master sends out an address called the "broadcast" address.

AAR can be configured as mode 2 or 3 (9-bit modes) and setting the SM2 bit in SCON. Each slave has its own SM2 bit set waiting for an address byte (9th bit = 1). The Receive Interrupt (RI) flag will only be set when the received byte matches either the given address or the broadcast address. Next, the slave then clears its SM2 bit to enable reception of the data bytes (9th bit = 0) from the master. When the 9th bit = 1, the master is sending an address. When the 9th bit = 0, the master is sending actual data.

If mode 1 is used, the stop bit takes the place of the 9th bit. Bit RI is set only when the received command frame address matches the device's address and is terminated by a valid stop bit. Note that mode 0 cannot be used. Setting SM2 bit in the SCON register in mode 0 will have no effect.

Each slave's individual address is specified by SFR SADDR. SFR SADEN is a mask byte that defines "don't care" bits to form the given address when combined with SADDR. See the example below:

Slave 1

SADDR = 1111 0001
 SADEN = 1111 1010
 GIVEN = 1111 0X0X

Slave 2

SADDR = 1111 0011
 SADEN = 1111 1001
 GIVEN = 1111 0XX1

Using the Given Address to Select Slaves

Any bits masked off by a 0 from SADEN become a "don't care" bit for the given address. Any bit masked off by a 1, becomes ANDED with SADDR. The "don't cares" provide flexibility in the user-defined addresses to address more slaves when using the given address.

Shown in the example above, Slave 1 has been given an address of 1111 0001 (SADDR). The SADEN byte has been used to mask off bits to a given address to allow more combinations of selecting Slave 1 and Slave 2. In this case for the given addresses, the last bit (LSB) of Slave 1 is a "don't care" and the last bit of Slave 2 is a 1. To communicate with Slave 1 and Slave 2, the master would need to send an address with the last bit equal to 1 (e.g. 1111 0001) since Slave 1's last bit is a don't care and Slave 2's last bit has to be a 1. To communicate with Slave 1 alone, the master would send an address with the last bit equal to 0 (e.g. 1111 0000), since Slave 2's last bit is a 1. See the table below for other possible combinations.

Select Slave 1 Only		
Slave 1	Given Address	Possible Addresses
	1111 0X0X	1111 0000 1111 0100

Select Slave 2 Only		
Slave 2	Given Address	Possible Addresses
	1111 0XX1	1111 0111 1111 0011

Select Slaves 1 & 2	
Slaves 1 & 2	Possible Addresses
	1111 0001 1111 0101

If the user added a third slave such as the example below:

Slave 3

SADDR = 1111 1001
 SADEN = 1111 0101
 GIVEN = 1111 X0X1

Select Slave 3 Only		
Slave 2	Given Address	Possible Addresses
	1111 X0X1	1111 1011 1111 1001

The user could use the possible addresses above to select slave 3 only. Another combination could be to select slave 2 and 3 only as shown below.

Select Slaves 2 & 3 Only	
Slaves 2 & 3	Possible Addresses
	1111 0011

More than one slave may have the same SADDR address as well, and a given address could be used to modify the address so that it is unique.

Using the Broadcast Address to Select Slaves

Using the broadcast address, the master can communicate with all the slaves at once. It is formed by performing a logical OR of SADDR and SADEN with '0's in the result treated as "don't cares".

Slave 1

1111 0001 = SADDR
 +1111 1010 = SADEN

 1111 1X11 = Broadcast

"Don't cares" allow for a wider range in defining the broadcast address, but in most cases, the broadcast address will be FFH.

On reset, SADDR and SADEN are "0". This produces an given address of all "don't cares" as well as a broadcast address of all "don't cares." This effectively disables Automatic Addressing mode and allows the microcontroller to function as a standard 8051, which does not make use of this feature.

Serial Peripheral Interface

SPI Features

- Master or slave operation
- 10 MHz bit frequency (max)
- LSB first or MSB first data transfer
- Four programmable bit rates
- End of transmission (SPIF)
- Write collision flag protection (WCOL)
- Wake up from idle mode (slave mode only)

SPI Description

The serial peripheral interface (SPI) allows high-speed synchronous data transfer between the SST89E/V516RDx and peripheral devices or between several SST89E/V516RDx devices.

Figure 20 shows the correspondence between master and slave SPI devices. The SCK pin is the clock output and input for the master and slave modes, respectively. The SPI clock generator will start following a write to the master devices SPI data register. The written data is then shifted out of the MOSI pin on the master device into the MOSI pin of the slave device. Following a complete transmission of one byte of data, the SPI clock generator is stopped and the SPIF flag is set. An SPI interrupt request will be generated if the SPI Interrupt Enable bit (SPIE) and the Serial Port Interrupt Enable bit (ES) are both set.

An external master drives the Slave Select input pin, SS#/P1[4], low to select the SPI module as a slave. If SS#/P1[4] has not been driven low, then the slave SPI unit is not active and the MOSI/P1[5] port can also be used as an input port pin.

CPHA and CPOL control the phase and polarity of the SPI clock. Figures 21 and 22 show the four possible combinations of these two bits.

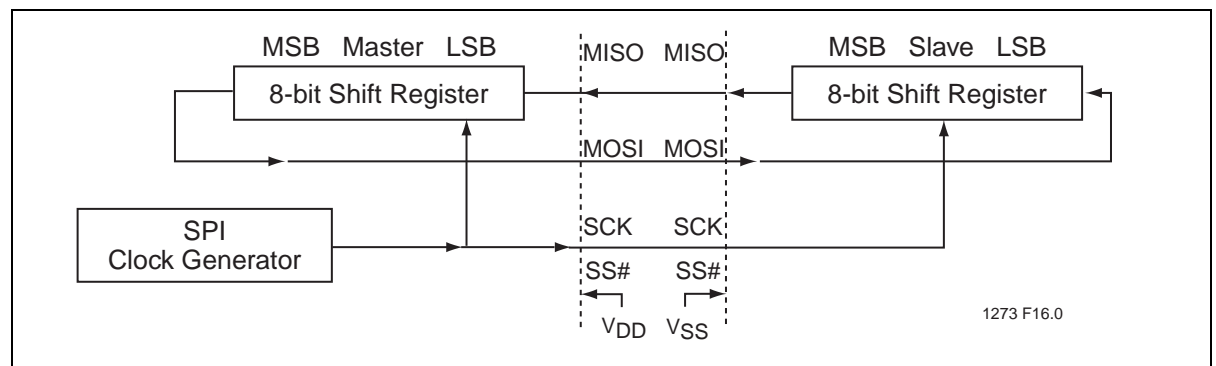

Figure 20: SPI Master-slave Interconnection

SPI Transfer Formats

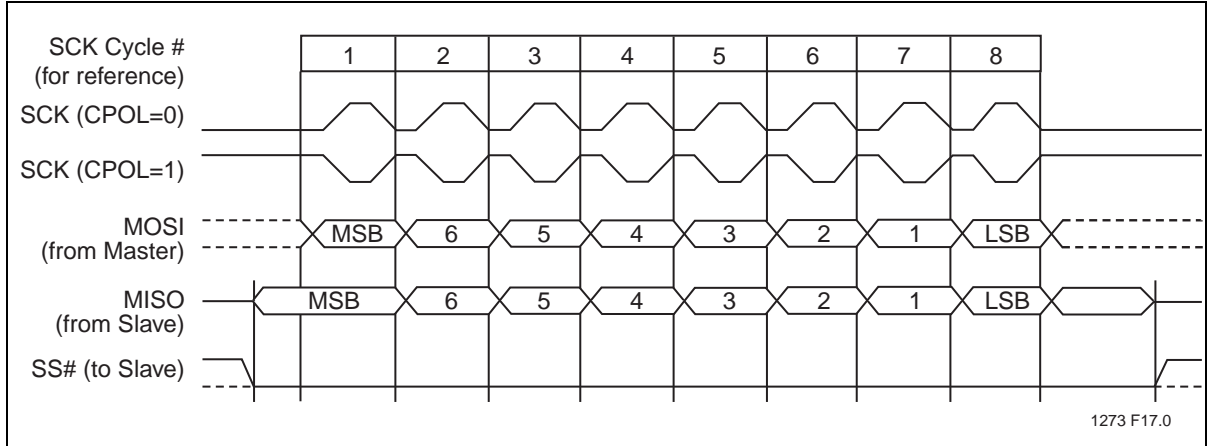

Figure 21: SPI Transfer Format with CPHA = 0

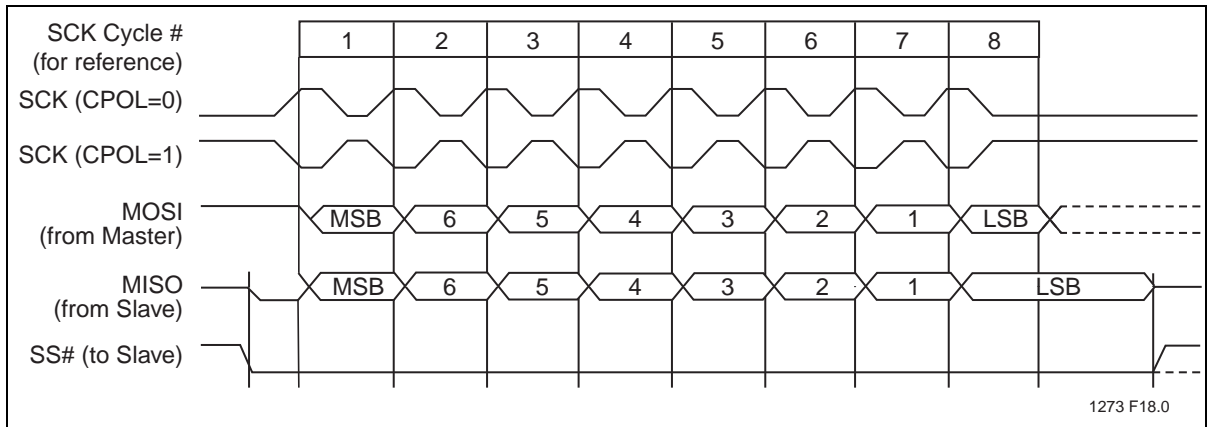

Figure 22: SPI Transfer Format with CPHA = 1

Programmable Counter Array

The Programmable Counter Array (PCA) present on the SST89E/V516RDx is a special 16-bit timer that has five 16-bit capture/compare modules. Each of the modules can be programmed to operate in one of four modes: rising and/or falling edge capture, software timer, high-speed output, or pulse width modulator. The 5th module can be programmed as a Watchdog Timer in addition to the other four modes. Each module has a pin associated with it in port 1. Module 0 is connected to P1.3 (CEX0), module 1 to P1[4] (CEX1), module 2 to P1[5] (CEX2), module 3 to P1[6] (CEX3), and module 4 to P1[7] (CEX4). PCA configuration is shown in Figure 24.

PCA Overview

PCA provides more timing capabilities with less CPU intervention than the standard timer/counter. Its advantages include reduced software overhead and improved accuracy.

The PCA consists of a dedicated timer/counter which serves as the time base for an array of five compare/capture modules. Figure 24 shows a block diagram of the PCA. External events associated with modules are shared with corresponding Port 1 pins. Modules not using the port pins can still be used for standard I/O.

Each of the five modules can be programmed in any of the following modes:

- Rising and/or falling edge capture
- Software timer
- High speed output
- Watchdog Timer (Module 4 only)
- Pulse Width Modulator (PWM)

PCA Timer/Counter

The PCA timer is a free-running 16-bit timer consisting of registers CH and CL (the high and low bytes of the count values). The PCA timer is common time base for all five modules and can be programmed to run at: 1/6 the oscillator frequency, 1/2 the oscillator frequency, Timer 0 overflow, or the input on the ECI pin (P1.2). The timer/counter source is determined from the CPS1 and CPS0 bits in the CMOD SFR as follows (see “PCA Timer/Counter Mode Register (CMOD)” on page 28):

Table 18: PCA Timer/Counter Source

CPS1	CPS0	12 Clock Mode	6 Clock Mode
0	0	$f_{osc} / 12$	$f_{osc} / 6$
0	1	$f_{osc} / 4$	$f_{osc} / 2$
1	0	Timer 0 overflow	Timer 0 overflow
1	1	External clock at ECI pin (maximum rate = $f_{osc} / 8$)	External clock at ECI pin (maximum rate = $f_{osc} / 4$)

T0-0.0 25093

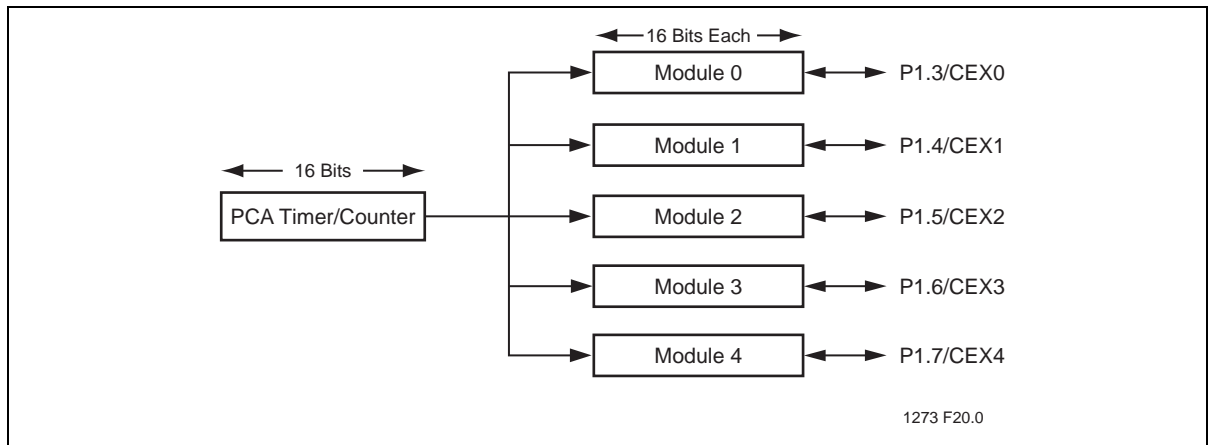

Figure 24:PCA Timer/Counter and Compare/Capture Modules

The table below summarizes various clock inputs at two common frequencies.

Table 19:PCA Timer/Counter Inputs

PCA Timer/Counter Mode	Clock Increments	
	12 MHz	16 MHz
Mode 0: $f_{osc}/12$	1 μ sec	0.75 μ sec
Mode 1:	330 nsec	250 nsec
Mode 2: Timer 0 Overflows ¹		
Timer 0 programmed in:		
8-bit mode	256 μ sec	192 μ sec
16-bit mode	65 msec	49 μ sec
8-bit auto-reload	1 to 255 μ sec	0.75 to 191 μ sec
Mode 3: External Input MAX	0.66 μ sec	0.50 μ sec

T0-0.0 25093

1. In Mode 2, the overflow interrupt for Timer 0 does not need to be enabled.

The four possible CMOD timer modes with and without the overflow interrupt enabled are shown below. This list assumes that PCA will be left running during idle mode.

Table 20:CMOD Values

PCA Count Pulse Selected	CMOD Value	
	Without Interrupt Enabled	With Interrupt Enabled
Internal clock, $f_{osc}/12$	00H	01H
Internal clock, $f_{osc}/4$	02H	03H
Timer 0 overflow	04H	05H
External clock at P1.2	06H	07H

T0-0.0 25093

The CCON register is associated with all PCA timer functions. It contains run control bits and flags for the PCA timer (CF) and all modules. To run the PCA the CR bit (CCON.6) must be set by software. Clearing the bit, will turn off PCA. When the PCA counter overflows, the CF (CCON.7) will be set, and

an interrupt will be generated if the ECF bit in the CMOD register is set. The CF bit can only be cleared by software. Each module has its own timer interrupt or capture interrupt flag (CCF0 for module 0, CCF4 for module 4, etc.). They are set when either a match or capture occurs. These flags can only be cleared by software. (See “PCA Timer/Counter Control Register (CCON)” on page 27.)

Compare/Capture Modules

Each PCA module has an associated SFR with it. These registers are: CCAPM0 for module 0, CCAPM1 for module 1, etc. Refer to “PCA Compare/Capture Module Mode Register (CCAPMn)” on page 29 for details. The registers each contain 7 bits which are used to control the mode each module will operate in. The ECCF bit (CCAPMn.0 where n = 0, 1, 2, 3, or 4 depending on module) will enable the CCF flag in the CCON SFR to generate an interrupt when a match or compare occurs. PWM (CCAPMn.1) enables the pulse width modulation mode. The TOG bit (CCAPMn.2) when set, causes the CEX output associated with the module to toggle when there is a match between the PCA counter and the module’s capture/compare register. When there is a match between the PCA counter and the module’s capture/compare register, the MATn (CCAPMn.3) and the CCFn bit in the CCON register to be set.

Bits CAPN (CCAPMn.4) and CAPP (CCAPMn.5) determine whether the capture input will be active on a positive edge or negative edge. The CAPN bit enables the negative edge that a capture input will be active on, and the CAPP bit enables the positive edge. When both bits are set, both edges will be enabled and a capture will occur for either transition. The last bit in the register ECOM (CCAPMn.6) when set, enables the comparator function. Table 22 shows the CCAPMn settings for the various PCA functions.

There are two additional register associated with each of the PCA modules: CCAPnH and CCAPnL. They are registers that hold the 16-bit count value when a capture occurs or a compare occurs. When a module is used in PWM mode, these registers are used to control the duty cycle of the output. See Figure 24.

Table 21: PCA High and Low Register Compare/Capture Modules

Symbol	Description	Direct Address	Bit Address, Symbol, or Alternative Port Function MSB	LSB	RESET Value
CCAP0H	PCA Module 0	FAH	CCAP0H[7:0]		00H
CCAP0L	Compare/Capture Registers	EAH	CCAP0L[7:0]		00H
CCAP1H	PCA Module 1	FBH	CCAP1H[7:0]		00H
CCAP1L	Compare/Capture Registers	EBH	CCAP1L[7:0]		00H
CCAP2H	PCA Module 2	FCH	CCAP2H[7:0]		00H
CCAP2L	Compare/Capture Registers	ECH	CCAP2L[7:0]		00H
CCAP3H	PCA Module 3	FDH	CCAP3H[7:0]		00H
CCAP3L	Compare/Capture Registers	EDH	CCAP3L[7:0]		00H
CCAP4H	PCA Module 4	FEH	CCAP4H[7:0]		00H
CCAP4L	Compare/Capture Registers	EEH	CCAP4L[7:0]		00H

T0-0.0 25093

Table 22: PCA Module Modes

Without Interrupt enabled								
-1	ECOMy ²	CAPPy ²	CAPNy ²	MATy ²	TOGy ²	PWMy ²	ECCFy ²	Module Code
-	0	0	0	0	0	0	0	No Operation
-	0	1	0	0	0	0	0	16-bit capture on positive-edge trigger at CEX[4:0]
-	0	0	1	0	0	0	0	16-bit capture on negative-edge trigger at CEX[4:0]
-	0	1	1	0	0	0	0	16-bit capture on positive/negative-edge trigger at CEX[4:0]
-	1	0	0	1	0	0	0	Compare: software timer
-	1	0	0	1	1	0	0	Compare: high-speed output
-	1	0	0	0	0	1	0	Compare: 8-bit PWM
-	1	0	0	1	0 or 1 ³	0	0	Compare: PCA WDT (CCAPM4 only) ⁴

T0-0.0 25093

1. User should not write '1's to reserved bits. The value read from a reserved bit is indeterminate.
2. y = 0, 1, 2, 3, 4
3. A 0 disables toggle function. A 1 enables toggle function on CEX[4:0] pin.
4. For PCA WDT mode, also set the WDTE bit in the CMOD register to enable the reset output signal.

Table 23: PCA Module Modes

With Interrupt enabled								
-1	ECOMy ²	CAPPy ²	CAPNy ²	MATy ²	TOGy ²	PWMy ²	ECCFy ²	Module Code
-	0	1	0	0	0	0	1	16-bit capture on positive-edge trigger at CEX[4:0]
-	0	0	1	0	0	0	1	16-bit capture on negative-edge trigger at CEX[4:0]
-	0	1	1	0	0	0	1	16-bit capture on positive/negative-edge trigger at CEX[4:0]
-	1	0	0	1	0	0	1	Compare: software timer
-	1	0	0	1	1	0	1	Compare: high-speed output
-	1	0	0	0	0	1	X ³	Compare: 8-bit PWM
-	1	0	0	1	0 or 1 ⁴	0	X ⁵	Compare: PCA WDT (CCAPM4 only) ⁶

T0-0.0 25093

1. User should not write '1's to reserved bits. The value read from a reserved bit is indeterminate.
2. y = 0, 1, 2, 3, 4
3. No PCA interrupt is needed to generate the PWM.
4. A 0 disables toggle function. A 1 enables toggle function on CEX[4:0] pin.
5. Enabling an interrupt for the Watchdog Timer would defeat the purpose of the Watchdog Timer.
6. For PCA WDT mode, also set the WDTE bit in the CMOD register to enable the reset output signal.

Capture Mode

Capture mode is used to capture the PCA timer/counter value into a module's capture registers (CCAPnH and CCAPnL). The capture will occur on a positive edge, negative edge, or both on the corresponding module's pin. To use one of the PCA modules in the capture mode, either one or both the CCAPM bits CAPN and CAPP for that module must be set. When a valid transition occurs on the CEX pin corresponding to the module used, the PCA hardware loads the 16-bit value of the PCA counter register (CH and CL) into the module's capture registers (CCAPnL and CCAPnH). If the CCFn bit for the module in the CCON SFR and the ECCFn bit in the CCAPMn SFR are set, then an interrupt will be generated. In the interrupt service routine, the 16-bit capture value must be saved in RAM before the next event capture occurs. If a subsequent capture occurred, the original capture values would be lost. After flag event flag has been set by hardware, the user must clear the flag in software. (See Figure 25)

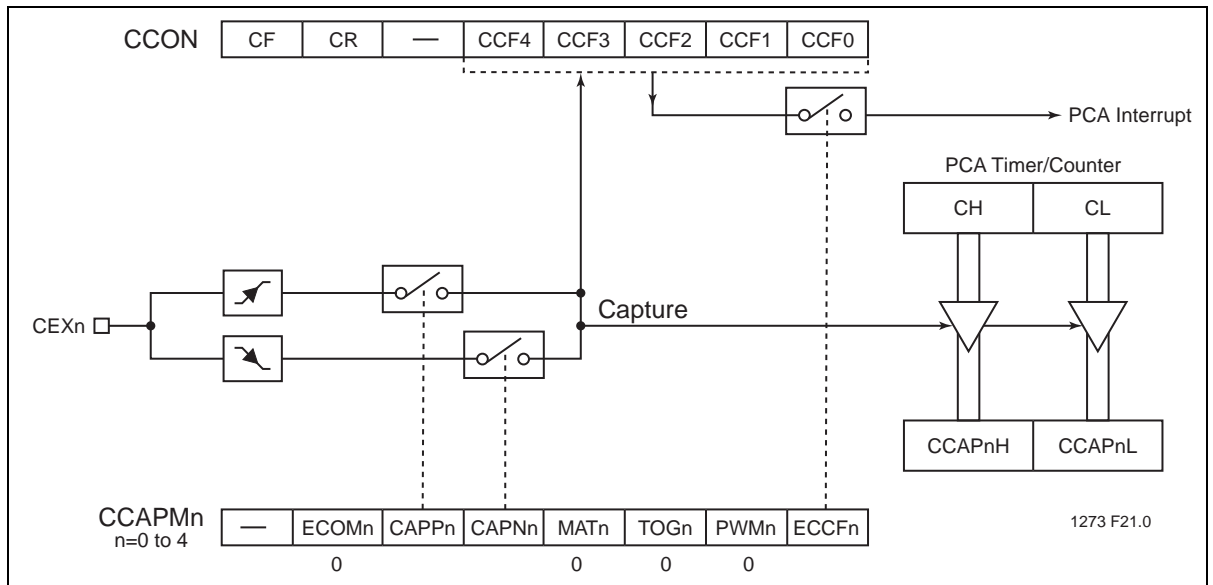

Figure 25:PCA Capture Mode

16-Bit Software Timer Mode

The 16-bit software timer mode is used to trigger interrupt routines, which must occur at periodic intervals. It is setup by setting both the ECOM and MAT bits in the module's CCAPMn register. The PCA timer will be compared to the module's capture registers (CCAPnL and CCAPnH) and when a match occurs, an interrupt will occur, if the CCFn (CCON SFR) and the ECCFn (CCAPMn SFR) bits for the module are both set.

If necessary, a new 16-bit compare value can be loaded into CCAPnH and CCAPnL during the interrupt routine. The user should be aware that the hardware temporarily disables the comparator function while these registers are being updated so that an invalid match will not occur. Thus, it is recommended that the user write to the low byte first (CCAPnL) to disable the comparator, then write to the high byte (CCAPnH) to re-enable it. If any updates to the registers are done, the user may want to hold off any interrupts from occurring by clearing the EA bit. (See Figure 26)

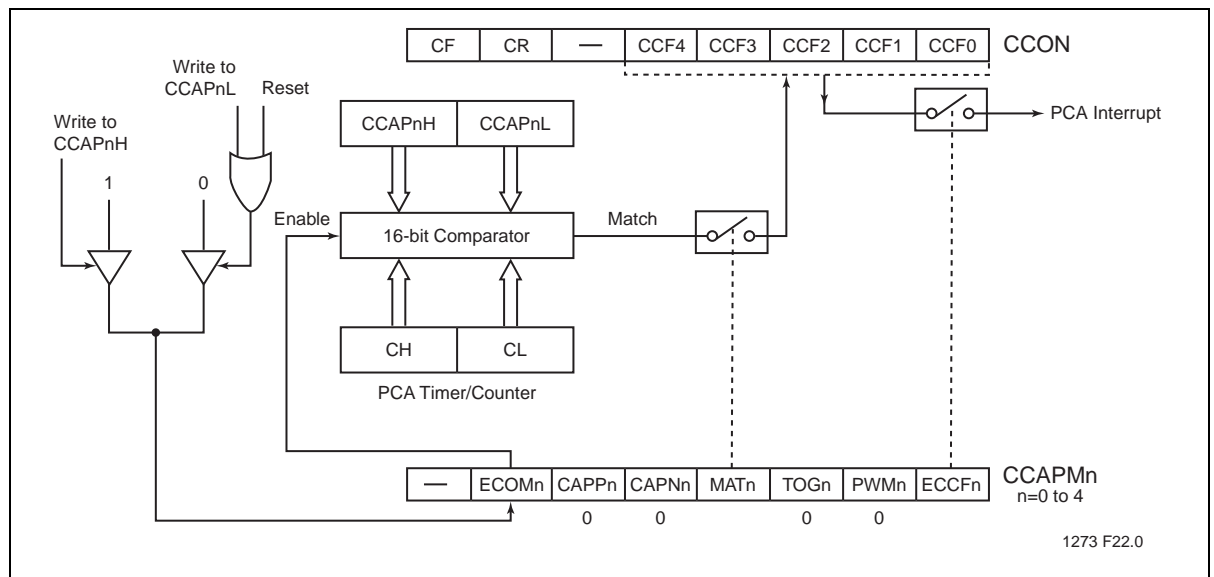

Figure 26:PCA Compare Mode (Software Timer)

High Speed Output Mode

The high speed output mode is used to toggle a port pin when a match occurs between the PCA timer and the preloaded value in the compare registers. In this mode, the CEX output pin (on port 1) associated with the PCA module will toggle every time there is a match between the PCA counter (CH and CL) and the capture registers (CCAPnH and CCAPnL). To activate this mode, the user must set TOG, MAT, and ECOM bits in the module's CCAPMn SFR.

High speed output mode is much more accurate than toggling pins since the toggle occurs before branching to an interrupt. In this case, interrupt latency will not affect the accuracy of the output. When using high speed output, using an interrupt is optional. Only if the user wishes to change the time for the next toggle is it necessary to update the compare registers. Otherwise, the next toggle will occur when the PCA timer rolls over and matches the last compare value. (See Figure 27)

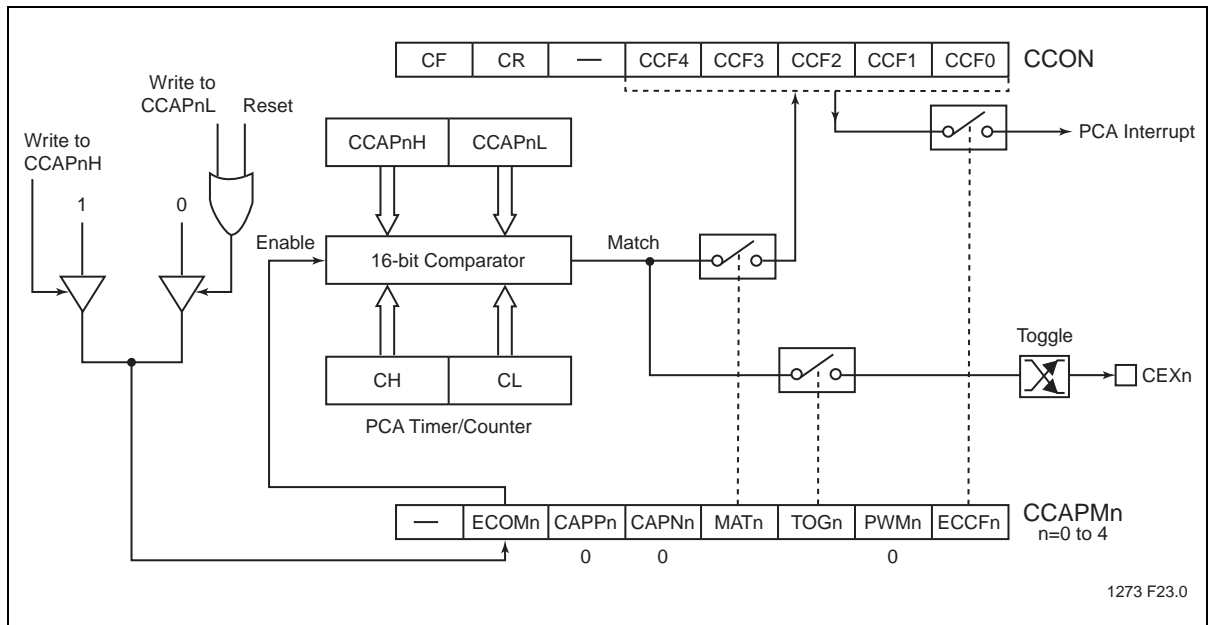

Figure 27:PCA High Speed Output Mode

Pulse Width Modulator

The Pulse Width Modulator (PWM) mode is used to generate 8-bit PWMs by comparing the low byte of the PCA timer (CL) with the low byte of the compare register (CCAPnL). When $CL < CCAPnL$ the output is low. When $CL \geq CCAPnL$ the output is high. To activate this mode, the user must set the PWM and ECOM bits in the module's CCAPMn SFR. (See Figure 28 and Table 24)

In PWM mode, the frequency of the output depends on the source for the PCA timer. Since there is only one set of CH and CL registers, all modules share the PCA timer and frequency. Duty cycle of the output is controlled by the value loaded into the high byte (CCAPnH). Since writes to the CCAPnH register are asynchronous, a new value written to the high byte will not be shifted into CCAPnL for comparison until the next period of the output (when CL rolls over from 255 to 00).

To calculate values for CCAPnH for any duty cycle, use the following equation:

$$CCAPnH = 256(1 - \text{Duty Cycle})$$

where CCAPnH is an 8-bit integer and Duty Cycle is a fraction.

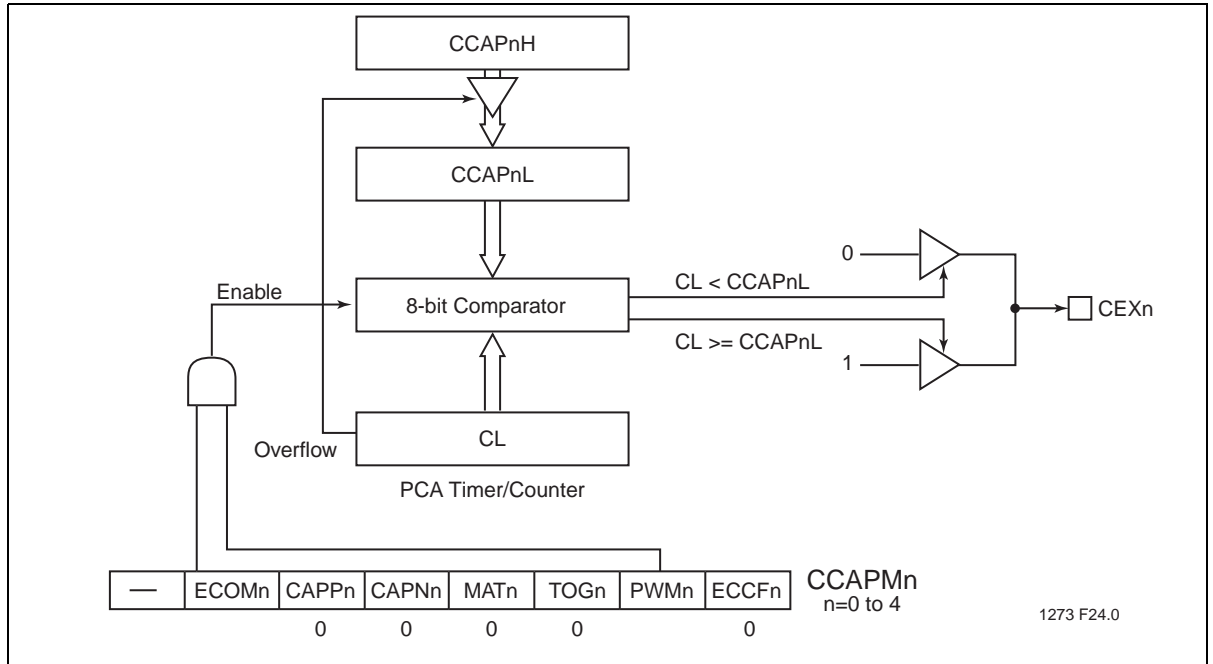

Figure 28:PCA Pulse Width Modulator Mode

Table 24:Pulse Width Modulator Frequencies

PCA Timer Mode	PWM Frequency	
	12 MHz	16 MHz
1/12 Oscillator Frequency	3.9 KHz	5.2 KHz
1/4 Oscillator Frequency	11.8 KHz	15.6 KHz
Timer 0 Overflow:		
8-bit	15.5 Hz	20.3 Hz
16-bit	0.06 Hz	0.08 Hz
8-bit Auto-Reload	3.9 KHz to 15.3 Hz	5.2 KHz to 20.3 Hz
External Input (Max)	5.9 KHz	7.8 KHz

T0-0.0 25093

Watchdog Timer

The Watchdog Timer mode is used to improve reliability in the system without increasing chip count (See Figure 29). Watchdog Timers are useful for systems that are susceptible to noise, power glitches, or electrostatic discharge. It can also be used to prevent a software deadlock. If during the execution of the user's code, there is a deadlock, the Watchdog Timer will time out and an internal reset will occur. Only module 4 can be programmed as a Watchdog Timer (but still can be programmed to other modes if the Watchdog Timer is not used).

To use the Watchdog Timer, the user pre-loads a 16-bit value in the compare register. Just like the other compare modes, this 16-bit value is compared to the PCA timer value. If a match is allowed to occur, an internal reset will be generated. This will not cause the RST pin to be driven high.

In order to hold off the reset, the user has three options:

1. periodically change the compare value so it will never match the PCA timer,
2. periodically change the PCA timer value so it will never match the compare values, or
3. disable the watchdog timer by clearing the WDTE bit before a match occurs and then re-enable it.

The first two options are more reliable because the Watchdog Timer is never disabled as in option #3. If the program counter ever goes astray, a match will eventually occur and cause an internal reset. The second option is also not recommended if other PCA modules are being used. Remember, the PCA timer is the time base for all modules; changing the time base for other modules would not be a good idea. Thus, in most application the first solution is the best option.

Use the code below to initialize the Watchdog Timer. Module 4 can be configured in either compare mode, and the WDTE bit in CMOD must also be set. The user's software then must periodically change (CCAP4H, CCAP4L) to keep a match from occurring with the PCA timer (CH, CL). This code is given in the Watchdog routine below.

```

;=====
Init_Watchdog:
MOVCCAPM4, #4CH; Module 4 in compare mode

MOVCCAP4L, #0FFH; Write to low byte first

MOVCCAP4H, #0FFH; Before PCA timer counts up
; to FFFF Hex, these compare
; values must be changed.

ORLCMOD, #40H; Set the WDTE bit to enable the
; watchdog timer without
; changing the other bits in
; CMOD

;=====

;Main program goes here, but call WATCHDOG periodically.

;=====

WATCHDOG:

```

```

CLR EA; Hold off interrupts

MOVCCAP4L, #00; Next compare value is within

MOVCCAP4H, CH; 65,535 counts of the
; current PCA

SETBEA; timer value

RET

;=====
  
```

This routine should not be part of an interrupt service routine. If the program counter goes astray and gets stuck in an infinite loop, interrupts will still be serviced and the watchdog will keep getting reset. Thus, the purpose of the watchdog would be defeated. Instead, call this subroutine from the main program of the PCA timer.

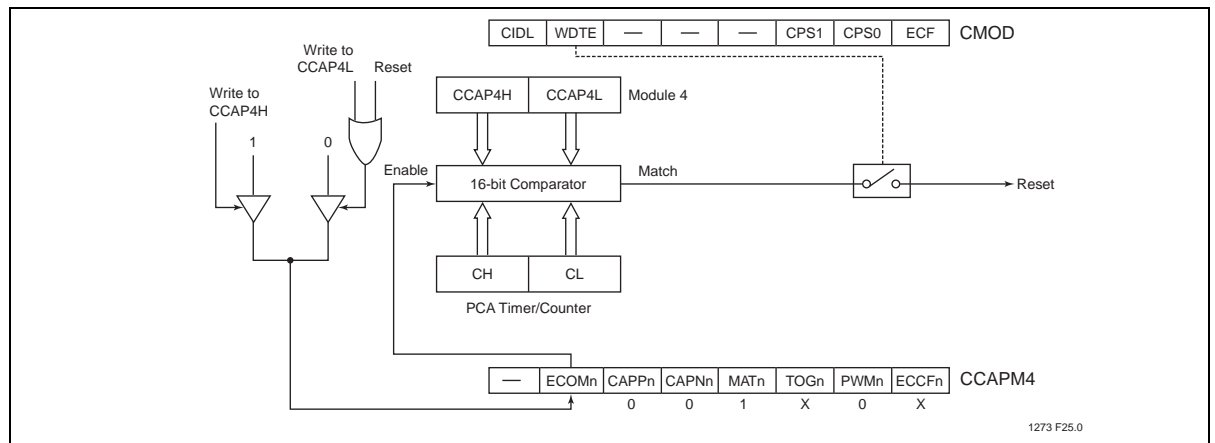

Figure 29:PCA Watchdog Timer (Module 4 only)

Security Lock

The security lock protects against software piracy and prevents the contents of the flash from being read by unauthorized parties. It also protects against code corruption resulting from accidental erasing and programming to the internal flash memory. There are two different types of security locks in the device security lock system: hard lock and SoftLock.

Hard Lock

When hard lock is activated, MOV_C or IAP instructions executed from an unlocked or soft locked program address space, are disabled from reading code bytes in hard locked memory blocks (See Table 26). Hard lock can either lock both flash memory blocks or just lock the 8 KByte flash memory block (Block 1). All external host and IAP commands except for Chip-Erase are ignored for memory blocks that are hard locked.

SoftLock

SoftLock allows flash contents to be altered under a secure environment. This lock option allows the user to update program code in the soft locked memory block through in-application programming mode under a predetermined secure environment. For example, if Block 1 (8K) memory block is locked (hard locked or soft locked), and Block 0 memory block is soft locked, code residing in Block 1 can program Block 0. The following IAP mode commands issued through the command mailbox register, SFCM, executed from a Locked (hard locked or soft locked) block, can be operated on a soft locked block: Block-Erase, Sector-Erase, Byte-Program and Byte-Verify.

In external host mode, SoftLock behaves the same as a hard lock.

Security Lock Status

The three bits that indicate the device security lock status are located in SFST[7:5]. As shown in Figure 30 and Table 25, the three security lock bits control the lock status of the primary and secondary blocks of memory. There are four distinct levels of security lock status. In the first level, none of the security lock bits are programmed and both blocks are unlocked. In the second level, although both blocks are now locked and cannot be programmed, they are available for read operation via Byte-Verify. In the third level, three different options are available: Block 1 hard lock / Block 0 SoftLock, SoftLock on both blocks, and hard lock on both blocks. Locking both blocks is the same as Level 2, Block 1 except read operation isn't available. The fourth level of security is the most secure level. It doesn't allow read/program of internal memory or boot from external memory. For details on how to program the security lock bits refer to the external host mode and in-application programming sections.

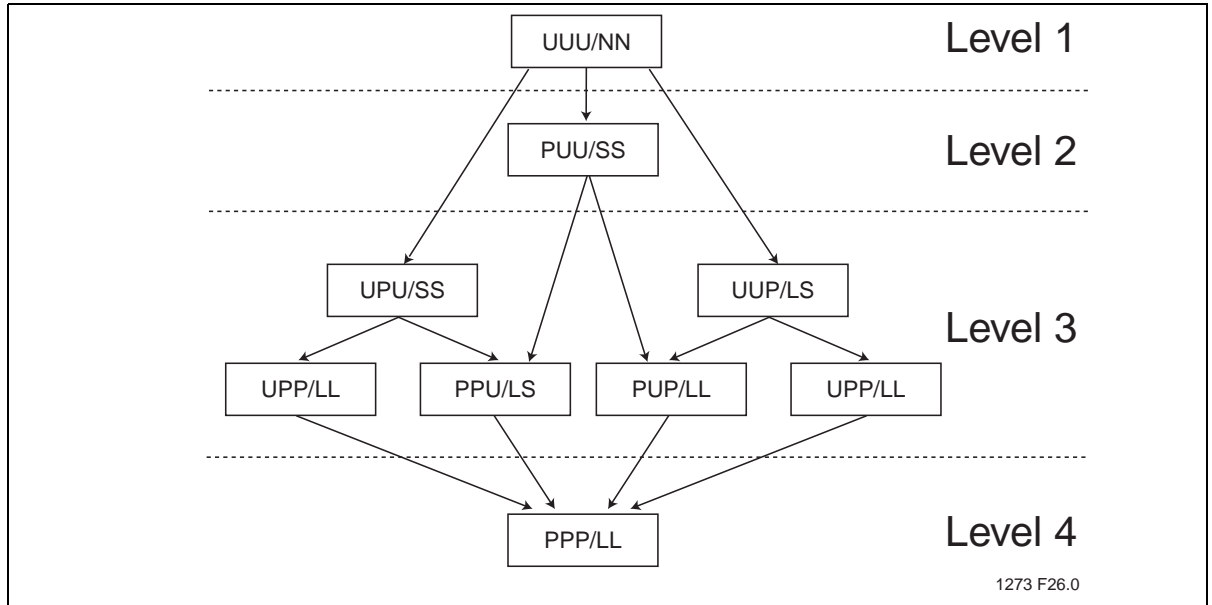

Figure 30: Security Lock Levels

Note: P = Programmed (Bit logic state = 0), U = Unprogrammed (Bit logic state = 1), N = Not Locked, L = Hard locked, S = Soft locked

Table 25: Security Lock Options

Level	Security Lock Bits ^{1,2}				Security Status of:		Security Type
	SFST[7:5]	SB1	SB2 ¹	SB3 ¹	Block 1	Block 0	
1	000	U	U	U	Unlock	Unlock	No Security Features are Enabled.
2	100	P	U	U	SoftLock	SoftLock	MOV _C instructions executed from external program memory are disabled from fetching code bytes from internal memory, EA# is sampled and latched on Reset, and further programming of the flash is disabled.
3	011	U	P	P	Hard Lock	Hard Lock	Level 2 plus Verify disabled, both blocks locked.
	101	P	U	P	SoftLock	SoftLock	Level 2 plus Verify disabled. Code in Block 1 may program Block 0 and vice versa.
	010	U	P	U	SoftLock	SoftLock	Level 2 plus Verify disabled. Code in Block 1 may program Block 0 and vice versa.
3	110	P	P	U	Hard Lock	SoftLock	Level 2 plus Verify disabled. Code in Block 1 may program Block 0.
	001	U	U	P	Hard Lock	SoftLock	Level 2 plus Verify disabled. Code in Block 1 may program Block 0.
4	111	P	P	P	Hard Lock	Hard Lock	Same as Level 3 hard lock/hard lock, but MCU will start code execution from the internal memory regardless of EA#.

TO-0.0 25093

1. P = Programmed (Bit logic state = 0), U = Unprogrammed (Bit logic state = 1).
2. SFST[7:5] = Security Lock Status Bits (SB1_i, SB2_i, SB3_i)

Read Operation Under Lock Condition

The status of security bits SB1, SB2, and SB3 can be read when the read command is disabled by security lock. There are three ways to read the status.

1. External host mode: Read-back = 00H (locked)
2. IAP command: Read-back = previous SFDT data
3. MOVC: Read-back = FFH (blank)

Table 26: Security Lock Access Table

Level	SFST[7:5]	Source Address ¹	Target Address ²	Byte-Verify Allowed		MOVC Allowed	
				External Host ³	IAP	516RDx	
4	111b (hard lock on both blocks)	Block 0/1	Block 0/1	N	N	Y	
			External	N/A	N/A	N	
		External	Block 0/1	N	N	N	
			External	N/A	N/A	N	
3	011b/101b (hard lock on both blocks)	Block 0/1	Block 0/1	N	N	Y	
			External	N/A	N/A	N	
		External	Block 0/1	N	N	N	
			External	N/A	N/A	Y	
	001b/110b (Block 0 = SoftLock, Block 1 = hard lock)	Block 0	Block 0	N	N	Y	
			Block 1	N	N	N	
			External	N/A	N/A	N	
		Block 1	Block 0	N	Y	Y	
			Block 1	N	N	Y	
			External	N/A	N/A	N	
		External	Block 0/1	N	N	N	
			External	N/A	N/A	Y	
			Block 0	N	N	Y	
			Block 1	N	Y	Y	
		010b (SoftLock on both blocks)	Block 0	Block 0	N	N	Y
				Block 1	N	Y	Y
	External			N/A	N/A	N	
	Block 1		Block 0	N	Y	Y	
			Block 1	N	N	Y	
			External	N/A	N/A	N	
External	Block 0/1		N	N	N		
	External		N/A	N/A	Y		
	Block 0		Y	N	Y		
	Block 1		Y	Y	Y		
2	100b (SoftLock on both blocks)		Block 0	Block 0	Y	N	Y
				Block 1	Y	Y	Y
		External		N/A	N/A	N	
		Block 1	Block 0	Y	Y	Y	
			Block 1	Y	N	Y	
			External	N/A	N/A	N	
		External	Block 0/1	Y	N	N	
			External	N/A	N/A	Y	

Table 26: Security Lock Access Table

Level	SFST[7:5]	Source Address ¹	Target Address ²	Byte-Verify Allowed		MOVC Allowed
				External Host ³	IAP	516RDx
1	000b (unlock)	Block 0	Block 0	Y	N	Y
			Block 1	Y	Y	Y
			External	N/A	N/A	N
		Block 1	Block 0	Y	Y	Y
			Block 1	Y	N	Y
			External	N/A	N/A	N
		External	Block 0/1	Y	Y	N
			External	N/A	N/A	Y

T0-0.0 25093

1. Location of MOVC or IAP instruction
2. Target address is the location of the byte being read
3. External host Byte-Verify access does not depend on a source address.

Reset

A system reset initializes the MCU and begins program execution at program memory location 0000H. The reset input for the device is the RST pin. In order to reset the device, a logic level high must be applied to the RST pin for at least two machine cycles (24 clocks), after the oscillator becomes stable. ALE, PSEN# are weakly pulled high during reset. During reset, ALE and PSEN# output a high level in order to perform a proper reset. This level must not be affected by external element. A system reset will not affect the 1 KByte of on-chip RAM while the device is running, however, the contents of the on-chip RAM during power up are indeterminate. Following reset, all Special Function Registers (SFR) return to their reset values outlined in Tables 6 to 10.

Power-on Reset

At initial power up, the port pins will be in a random state until the oscillator has started and the internal reset algorithm has weakly pulled all pins high. **Powering up the device without a valid reset could cause the MCU to start executing instructions from an indeterminate location. Such undefined states may inadvertently corrupt the code in the flash.**

When power is applied to the device, the RST pin must be held high long enough for the oscillator to start up (usually several milliseconds for a low frequency crystal), in addition to two machine cycles for a valid power-on reset. An example of a method to extend the RST signal is to implement a RC circuit by connecting the RST pin to V_{DD} through a $10\ \mu\text{F}$ capacitor and to V_{SS} through an $8.2\text{K}\Omega$ resistor as shown in Figure 31. Note that if an RC circuit is being used, provisions should be made to ensure the V_{DD} rise time does not exceed 1 millisecond and the oscillator start-up time does not exceed 10 milliseconds.

For a low frequency oscillator with slow start-up time the reset signal must be extended in order to account for the slow start-up time. This method maintains the necessary relationship between V_{DD} and RST to avoid programming at an indeterminate location, which may cause corruption in the code of the flash. The power-on detection is designed to work as power up initially, before the voltage reaches the brown-out detection level. The POF flag in the PCON register is set to indicate an initial power up condition. The POF flag will remain active until cleared by software. Please see Section , “Power Control Register (PCON)” on page 31 for detailed information.

For more information on system level design techniques, please review the *FlashFlex MCU: Oscillator Circuit Design Considerations* application note.

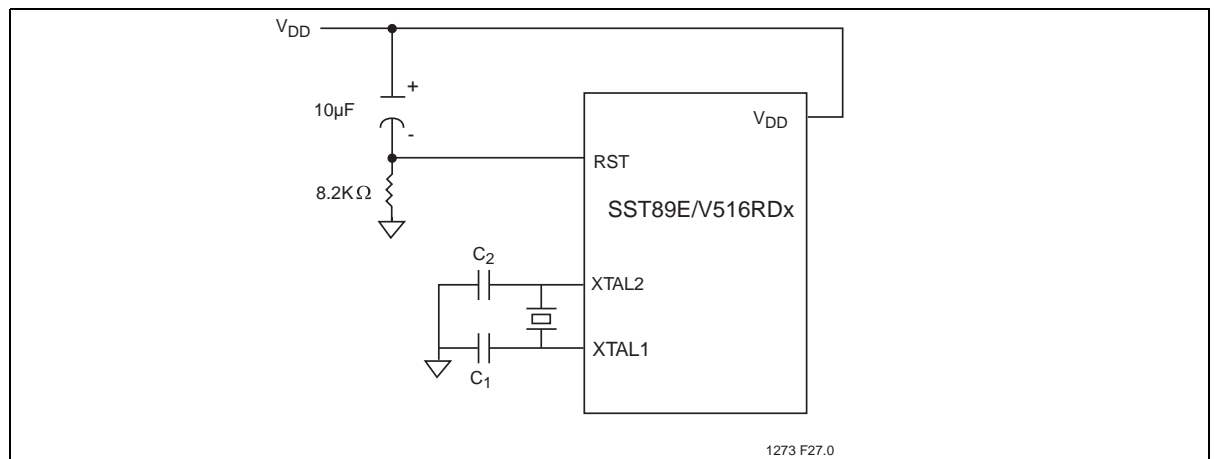

Figure 31:Power-on Reset Circuit

Software Reset

The software reset is executed by changing SFCF[1] (SWR) from “0” to “1”. A software reset will reset the program counter to address 0000H. All SFR registers will be set to their reset values, except SFCF[1] (SWR), WDTC[2] (WDTS), and RAM data will not be altered.

Brown-out Detection Reset

The device includes a brown-out detection circuit to protect the system from severed supplied voltage V_{DD} fluctuations. SST89E516RDx internal brown-out detection threshold is 3.85V, SST89V516RDx brown-out detection threshold is 2.35V. For brown-out voltage parameters, please refer to Table 36.

When V_{DD} drops below this voltage threshold, the brown-out detector triggers the circuit to generate a brown-out interrupt but the CPU still runs until the supplied voltage returns to the brown-out detection voltage V_{BOD} . The default operation for a brown-out detection is to cause a processor reset.

V_{DD} must stay below V_{BOD} at least four oscillator clock periods before the brown-out detection circuit will respond.

Brown-out interrupt can be enabled by setting the EBO bit in IEA register (address E8H, bit 3). If EBO bit is set and a brown-out condition occurs, a brown-out interrupt will be generated to execute the program at location 004BH. It is required that the EBO bit be cleared by software after the brown-out interrupt is serviced. Clearing EBO bit when the brown-out condition is active will properly reset the device. If brown-out interrupt is not enabled, a brown-out condition will reset the program to resume execution at location 0000H.

Interrupts

Interrupt Priority and Polling Sequence

The device supports eight interrupt sources under a four level priority scheme. Table 27 summarizes the polling sequence of the supported interrupts. Note that the SPI serial interface and the UART share the same interrupt vector. (See Figure 32)

Table 27: Interrupt Polling Sequence

Description	Interrupt Flag	Vector Address	Interrupt Enable	Interrupt Priority	Service Priority	Wake-Up Power-down
Ext. Int0	IE0	0003H	EX0	PX0/H	1(highest)	yes
Brown-out	-	004BH	EBO	PBO/H	2	no
T0	TF0	000BH	ET0	PT0/H	3	no
Ext. Int1	IE1	0013H	EX1	PX1/H	4	yes
T1	TF1	001BH	ET1	PT1/H	5	no
PCA	CF/CCFn	0033H	EC	PPCH	6	no
Ext. Int. 2	IE2	003BH	EX2	PX2/H	7	no
Ext. Int. 3	IE3	0043H	EX3	PX3/H	8	no
UART/SPI	TI/RI/SPIF	0023H	ES	PS/H	9	no
T2	TF2, EXF2	002BH	ET2	PT2/H	10	no

T0-0.0 25093

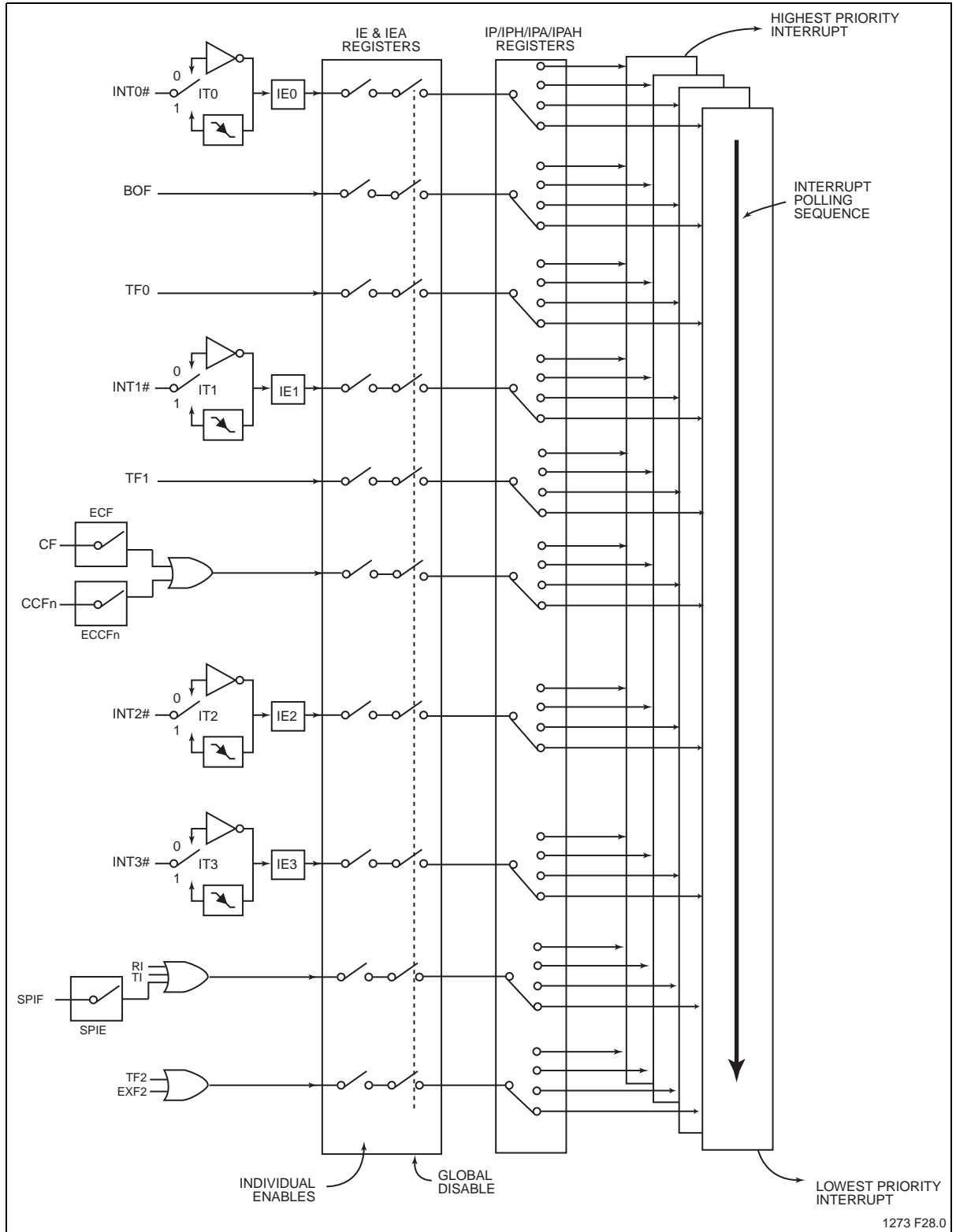

Figure 32: Interrupt Structure

1273 F28.0

Power-Saving Modes

The device provides two power saving modes of operation for applications where power consumption is critical. The two modes are idle and power-down, see Table 28.

Idle Mode

Idle mode is entered setting the IDL bit in the PCON register. In idle mode, the program counter (PC) is stopped. The system clock continues to run and all interrupts and peripherals remain active. The on-chip RAM and the special function registers hold their data during this mode.

The device exits idle mode through either a system interrupt or a hardware reset. Exiting idle mode via system interrupt, the start of the interrupt clears the IDL bit and exits idle mode. After exit the Interrupt Service Routine, the interrupted program resumes execution beginning at the instruction immediately following the instruction which invoked the idle mode. A hardware reset starts the device similar to a power-on reset.

Power-down Mode

The power-down mode is entered by setting the PD bit in the PCON register. In the power-down mode, the clock is stopped and external interrupts are active for level sensitive interrupts only. SRAM contents are retained during power-down, the minimum V_{DD} level is 2.0V.

The device exits power-down mode through either an enabled external level sensitive interrupt or a hardware reset. The start of the interrupt clears the PD bit and exits power-down. Holding the external interrupt pin low restarts the oscillator, the signal must hold low at least 1024 clock cycles before bringing back high to complete the exit. Upon interrupt signal being restored to logic V_{IH} , the first instruction of the interrupt service routine will execute. A hardware reset starts the device similar to power-on reset.

To exit properly out of power-down, the reset or external interrupt should not be executed before the V_{DD} line is restored to its normal operating voltage. Be sure to hold V_{DD} voltage long enough at its normal operating level for the oscillator to restart and stabilize (normally less than 10 ms).

Table 28: Power Saving Modes

Mode	Initiated by	State of MCU	Exited by
Idle Mode	Software (Set IDL bit in PCON) MOV PCON, #01H;	CLK is running. Interrupts, serial port and timers/counters are active. Program Counter is stopped. ALE and PSEN# signals at a HIGH level during Idle. All registers remain unchanged.	Enabled interrupt or hardware reset. Start of interrupt clears IDL bit and exits idle mode, after the ISR RETI instruction, program resumes execution beginning at the instruction following the one that invoked idle mode. A user could consider placing two or three NOP instructions after the instruction that invokes idle mode to eliminate any problems. A hardware reset restarts the device similar to a power-on reset.
Power-down Mode	Software (Set PD bit in PCON) MOV PCON, #02H;	CLK is stopped. On-chip SRAM and SFR data is maintained. ALE and PSEN# signals at a LOW level during power -down. External Interrupts are only active for level sensitive interrupts, if enabled.	Enabled external level sensitive interrupt or hardware reset. Start of interrupt clears PD bit and exits power-down mode, after the ISR RETI instruction program resumes execution beginning at the instruction following the one that invoked power-down mode. A user could consider placing two or three NOP instructions after the instruction that invokes power-down mode to eliminate any problems. A hardware reset restarts the device similar to a power-on reset.

TO-0.0 25093

System Clock and Clock Options

Clock Input Options and Recommended Capacitor Values for Oscillator

Shown in Figure 33 are the input and output of an internal inverting amplifier (XTAL1, XTAL2), which can be configured for use as an on-chip oscillator.

When driving the device from an external clock source, XTAL2 should be left disconnected and XTAL1 should be driven.

At start-up, the external oscillator may encounter a higher capacitive load at XTAL1 due to interaction between the amplifier and its feedback capacitance. However, the capacitance will not exceed 15 pF once the external signal meets the V_{IL} and V_{IH} specifications.

Crystal manufacturer, supply voltage, and other factors may cause circuit performance to differ from one application to another. C1 and C2 should be adjusted appropriately for each design. Table 29, shows the typical values for C1 and C2 vs. crystal type for various frequencies

Table 29: Recommended Values for C1 and C2 by Crystal Type

Crystal	C1 = C2
Quartz	20-30pF
Ceramic	40-50pF

T0-0.0 25093

More specific information about on-chip oscillator design can be found in the *FlashFlex Oscillator Circuit Design Considerations* application note.

Clock Doubling Option

By default, the device runs at 12 clocks per machine cycle (x1 mode). The device has a clock doubling option to speed up to 6 clocks per machine cycle. Please refer to Table 30 for detail.

Clock double mode can be enabled either via the external host mode or the IAP mode. Please refer to Table 14 for the IAP mode enabling commands (When set, the EDC# bit in SFST register will indicate 6 clock mode.).

The clock double mode is only for doubling the internal system clock and the internal flash memory, i.e. EA#=1. To access the external memory and the peripheral devices, careful consideration must be taken. Also note that the crystal output (XTAL2) will not be doubled.

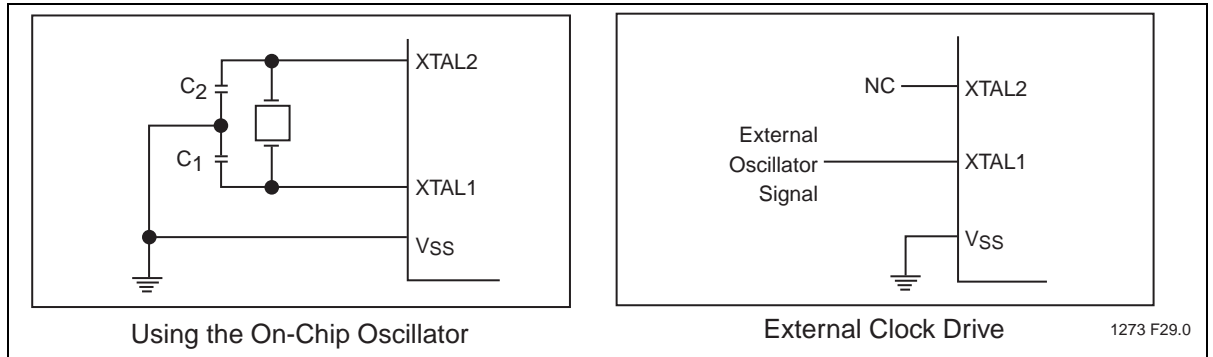

Figure 33: Oscillator Characteristics

Table 30: Clock Doubling Features

Device	Standard Mode (x1)		Clock Double Mode (x2)	
	Clocks per Machine Cycle	Max. External Clock Frequency (MHz)	Clocks per Machine Cycle	Max. External Clock Frequency (MHz)
SST89E516RDx	12	40	6	20
SST89V516RDx	12	33	6	16

T0-0.0 25093

Electrical Specification

Absolute Maximum Stress Ratings (Applied conditions greater than those listed under “Absolute Maximum Stress Ratings” may cause permanent damage to the device. This is a stress rating only and functional operation of the device at these conditions or conditions greater than those defined in the operational sections of this data sheet is not implied. Exposure to absolute maximum stress rating conditions may affect device reliability.)

Ambient Temperature Under Bias	-55°C to +125°C
Storage Temperature	-65°C to +150° C
Voltage on EA# Pin to V _{SS}	-0.5V to +14.0V
D.C. Voltage on Any Pin to Ground Potential	-0.5V to V _{DD} +0.5V
Transient Voltage (<20ns) on Any Other Pin to V _{SS}	-1.0V to V _{DD} +1.0V
Maximum I _{OL} per I/O Pins P1.5, P1.6, P1.7	20mA
Maximum I _{OL} per I/O for All Other Pins	15mA
Package Power Dissipation Capability (T _A = 25°C)	1.5W
Through Hole Lead Soldering Temperature (10 Seconds)	300°C
Surface Mount Solder Reflow Temperature ¹	260°C for 10 seconds
Output Short Circuit Current ²	50 mA

1. Excluding certain with-Pb 32-PLCC units, all packages are 260°C capable in both non-Pb and with-Pb solder versions. Certain with-Pb 32-PLCC package types are capable of 240°C for 10 seconds; please consult the factory for the latest information.
2. Outputs shorted for no more than one second. No more than one output shorted at a time. (Based on package heat transfer limitations, not device power consumption.)

Note: This specification contains preliminary information on new products in production. The specifications are subject to change without notice.

Table 31: Operating Range

Symbol	Description	Min.	Max	Unit
T _A	Ambient Temperature Under Bias			
	Standard	0	+70	°C
	Industrial	-40	+85	°C
V _{DD}	Supply Voltage			
	SST89E516RDx	4.5	5.5	V
	SST89V516RDx	2.7	3.6	V
f _{osc}	Oscillator Frequency			
	SST89E516RDx	0	40	MHz
	SST89V516RDx	0	33	MHz
	Oscillator Frequency for IAP			
	SST89E516RDx	.25	40	MHz
	SST89V516RDx	.25	33	MHz

T0-0.0 25093

Table 32: Reliability Characteristics

Symbol	Parameter	Minimum Specification	Units	Test Method
N _{END} ¹	Endurance	10,000	Cycles	JEDEC Standard A117
T _{DR} ¹	Data Retention	100	Years	JEDEC Standard A103
I _{LTH} ¹	Latch Up	100 + I _{DD}	mA	JEDEC Standard 78

T0-0.0 25093

1. This parameter is measured only for initial qualification and after a design or process change that could affect this parameter.

Table 33: AC Conditions of Test¹

Input Rise/Fall Time	Output Load
10 ns	C _L = 100 pF

T33.1 25093

1. See Figures 41 and 43

Table 34: Recommended System Power-up Timings

Symbol	Parameter	Minimum	Units
T _{PU-READ} ¹	Power-up to Read Operation	100	μs
T _{PU-WRITE} ¹	Power-up to Write Operation	100	μs

T0-0.0 25093

1. This parameter is measured only for initial qualification and after a design or process change that could affect this parameter

Table 35: Pin Impedance (V_{DD}=3.3V, T_A=25°C, f=1 Mhz, other pins open)

Parameter	Description	Test Condition	Maximum
C _{I/O} ¹	I/O Pin Capacitance	V _{I/O} = 0V	15 pF
C _{IN} ¹	Input Capacitance	V _{IN} = 0V	12 pF
L _{PIN} ²	Pin Inductance		20 nH

T0-0.0 25093

1. This parameter is measured only for initial qualification and after a design or process change that could affect this parameter.
2. Refer to PCI spec.

DC Electrical Characteristics

Table 36: DC Electrical Characteristics for SST89E516RDx
 $T_A = -40^{\circ}\text{C}$ to $+85^{\circ}\text{C}$; $V_{DD} = 4.5\text{-}5.5\text{V}$; $V_{SS} = 0\text{V}$

Symbol	Parameter	Test Conditions	Min	Max	Units
V_{IL}	Input Low Voltage	$4.5 < V_{DD} < 5.5$	-0.5	$0.2V_{DD} - 0.1$	V
V_{IH}	Input High Voltage	$4.5 < V_{DD} < 5.5$	$0.2V_{DD} + 0.9$	$V_{DD} + 0.5$	V
V_{IH1}	Input High Voltage (XTAL1, RST)	$4.5 < V_{DD} < 5.5$	$0.7V_{DD}$	$V_{DD} + 0.5$	V
V_{OL}	Output Low Voltage (Ports 1.5, 1.6, 1.7)	$V_{DD} = 4.5\text{V}$			
		$I_{OL} = 16\text{mA}$		1.0	V
V_{OL}	Output Low Voltage (Ports 1, 2, 3) ¹	$V_{DD} = 4.5\text{V}$			
		$I_{OL} = 100\mu\text{A}^2$		0.3	V
		$I_{OL} = 1.6\text{mA}^2$		0.45	V
		$I_{OL} = 3.5\text{mA}^2$		1.0	V
V_{OL1}	Output Low Voltage (Port 0, ALE, PSEN#) ^{1,3}	$V_{DD} = 4.5\text{V}$			
		$I_{OL} = 200\mu\text{A}^2$		0.3	V
		$I_{OL} = 3.2\text{mA}^2$		0.45	V
V_{OH}	Output High Voltage (Ports 1, 2, 3, ALE, PSEN#) ⁴	$V_{DD} = 4.5\text{V}$			
		$I_{OH} = -10\mu\text{A}$	$V_{DD} - 0.3$		V
		$I_{OH} = -30\mu\text{A}$	$V_{DD} - 0.7$		V
		$I_{OH} = -60\mu\text{A}$	$V_{DD} - 1.5$		V
V_{OH1}	Output High Voltage (Port 0 in External Bus Mode) ⁴	$V_{DD} = 4.5\text{V}$			
		$I_{OH} = -200\mu\text{A}$	$V_{DD} - 0.3$		V
		$I_{OH} = -3.2\text{mA}$	$V_{DD} - 0.7$		V
V_{BOD}	Brown-out Detection Voltage		3.85	4.15	V
I_{IL}	Logical 0 Input Current (Ports 1, 2, 3)	$V_{IN} = 0.4\text{V}$		-75	μA
I_{TL}	Logical 1-to-0 Transition Current (Ports 1, 2, 3) ⁵	$V_{IN} = 2\text{V}$		-650	μA
I_{LI}	Input Leakage Current (Port 0)	$0.45 < V_{IN} < V_{DD} - 0.3$		± 10	μA
R_{RST}	RST Pull-down Resistor		40	225	$\text{K}\Omega$
C_{IO}	Pin Capacitance ⁶	@ 1 MHz, 25°C		15	pF
I_{DD}	Power Supply Current				
	IAP Mode @ 40 MHz			88	mA
	Active Mode @ 40 MHz			50	mA
	Idle Mode @ 40 MHz			42	mA
	Power-down Mode (min. $V_{DD} = 2\text{V}$)	$T_A = 0^{\circ}\text{C}$ to $+70^{\circ}\text{C}$		80	μA
	$T_A = -40^{\circ}\text{C}$ to $+85^{\circ}\text{C}$		90	μA	

TO-0.1 25093

1. Under steady state (non-transient) conditions, I_{OL} must be externally limited as follows:
Maximum I_{OL} per port pin: 15mA
Maximum I_{OL} per 8-bit port: 26mA
Maximum I_{OL} total for all outputs: 71mA
If I_{OL} exceeds the test condition, V_{OL} may exceed the related specification.
Pins are not guaranteed to sink current greater than the listed test conditions.
2. Capacitive loading on Ports 0 and 2 may cause spurious noise to be superimposed on the V_{OLS} of ALE and Ports 1 & 3. The noise due to external bus capacitance discharging into the Port 0 & 2 pins when the pins make 1-to-0 transitions during bus operations. In the worst cases (capacitive loading > 100pF), the noise pulse on the ALE pin may exceed 0.8V. In such cases, it may be desirable to qualify ALE with a Schmitt Trigger, or use an address latch with a Schmitt Trigger STROBE input.
3. Load capacitance for Port 0, ALE & PSEN# = 100pF, load capacitance for all other outputs = 80pF.
4. Capacitive loading on Ports 0 and 2 may cause the V_{OH} on ALE and PSEN# to momentarily fall below the $V_{DD} - 0.7$ specification when the address bits are stabilizing.
5. Pins of Ports 1, 2, and 3 source a transition current when they are being externally driven from 1 to 0. The transition current reaches its maximum value when V_{IN} is approximately 2V.
6. Pin capacitance is characterized but not tested. EA# is 25pF (max).

Table 37: DC Electrical Characteristics for SST89V516RDx
 $T_A = -40^{\circ}\text{C}$ to $+85^{\circ}\text{C}$; $V_{DD} = 2.7\text{-}3.6\text{V}$; $V_{SS} = 0\text{V}$

Symbol	Parameter	Test Conditions	Min	Max	Units
V_{IL}	Input Low Voltage	$2.7 < V_{DD} < 3.6$	-0.5	0.7	V
V_{IH}	Input High Voltage	$2.7 < V_{DD} < 3.6$	$0.2V_{DD} + 0.9$	$V_{DD} + 0.5$	V
V_{IH1}	Input High Voltage (XTAL1, RST)	$2.7 < V_{DD} < 3.6$	$0.7V_{DD}$	$V_{DD} + 0.5$	V
V_{OL}	Output Low Voltage (Ports 1.5, 1.6, 1.7)	$V_{DD} = 2.7\text{V}$			
		$I_{OL} = 16\text{mA}$		1.0	V
V_{OL}	Output Low Voltage (Ports 1, 2, 3) ¹	$V_{DD} = 2.7\text{V}$			
		$I_{OL} = 100\mu\text{A}^2$		0.3	V
		$I_{OL} = 1.6\text{mA}^2$		0.45	V
		$I_{OL} = 3.5\text{mA}^2$		1.0	V
V_{OL1}	Output Low Voltage (Port 0, ALE, PSEN#) ^{1,3}	$V_{DD} = 2.7\text{V}$			
		$I_{OL} = 200\mu\text{A}^2$		0.3	V
		$I_{OL} = 3.2\text{mA}^2$		0.45	V
V_{OH}	Output High Voltage (Ports 1, 2, 3, ALE, PSEN#) ⁴	$V_{DD} = 2.7\text{V}$			
		$I_{OH} = -10\mu\text{A}$	$V_{DD} - 0.3$		V
		$I_{OH} = -30\mu\text{A}$	$V_{DD} - 0.7$		V
		$I_{OH} = -60\mu\text{A}$	$V_{DD} - 1.5$		V
V_{OH1}	Output High Voltage (Port 0 in External Bus Mode) ⁴	$V_{DD} = 2.7\text{V}$			
		$I_{OH} = -200\mu\text{A}$	$V_{DD} - 0.3$		V
		$I_{OH} = -3.2\text{mA}$	$V_{DD} - 0.7$		V
V_{BOD}	Brown-out Detection Voltage		2.35	2.55	V
I_{IL}	Logical 0 Input Current (Ports 1, 2, 3)	$V_{IN} = 0.4\text{V}$		-75	μA
I_{TL}	Logical 1-to-0 Transition Current (Ports 1, 2, 3) ⁵	$V_{IN} = 2\text{V}$		-650	μA
I_{LI}	Input Leakage Current (Port 0)	$0.45 < V_{IN} < V_{DD} - 0.3$		± 10	μA
R_{RST}	RST Pull-down Resistor			225	$\text{K}\Omega$
C_{IO}	Pin Capacitance ⁶	@ 1 MHz, 25°C		15	pF
I_{DD}	Power Supply Current				
	IAP Mode @ 33 MHz			47	mA
	Active Mode @ 33 MHz			30	mA
	Idle Mode @ 33 MHz			21	mA
	Power-down Mode (min. $V_{DD} = 2\text{V}$)	$T_A = 0^{\circ}\text{C}$ to $+70^{\circ}\text{C}$		45	μA
	$T_A = -40^{\circ}\text{C}$ to $+85^{\circ}\text{C}$		55	μA	

T0-0.1 25093

1. Under steady state (non-transient) conditions, I_{OL} must be externally limited as follows:
 - Maximum I_{OL} per port pin: 15mA
 - Maximum I_{OL} per 8-bit port: 26mA
 - Maximum I_{OL} total for all outputs: 71mAIf I_{OL} exceeds the test condition, V_{OL} may exceed the related specification. Pins are not guaranteed to sink current greater than the listed test conditions.
2. Capacitive loading on Ports 0 and 2 may cause spurious noise to be superimposed on the V_{OLS} of ALE and Ports 1 & 3. The noise due to external bus capacitance discharging into the Port 0 & 2 pins when the pins make 1-to-0 transitions during bus operations. In the worst cases (capacitive loading > 100pF), the noise pulse on the ALE pin may exceed 0.8V. In such cases, it may be desirable to qualify ALE with a Schmitt Trigger, or use an address latch with a Schmitt Trigger STROBE input.
3. Load capacitance for Port 0, ALE & PSEN# = 100pF, load capacitance for all other outputs = 80pF.
4. Capacitive loading on Ports 0 & 2 may cause the V_{OH} on ALE and PSEN# to momentarily fall below the $V_{DD} - 0.7$ specification when the address bits are stabilizing.
5. Pins of Ports 1, 2, and 3 source a transition current when they are being externally driven from 1 to 0. The transition current reaches its maximum value when V_{IN} is approximately 2V.
6. Pin capacitance is characterized but not tested. EA# is 25pF (max).

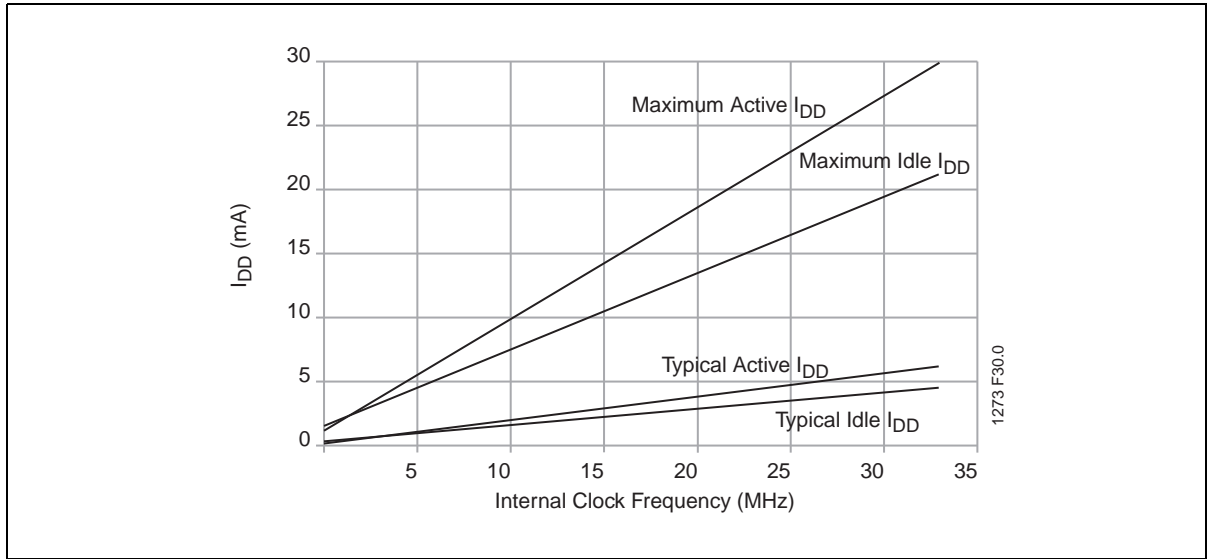

Figure 34: I_{DD} vs. Frequency for 3V SST89V516RDx

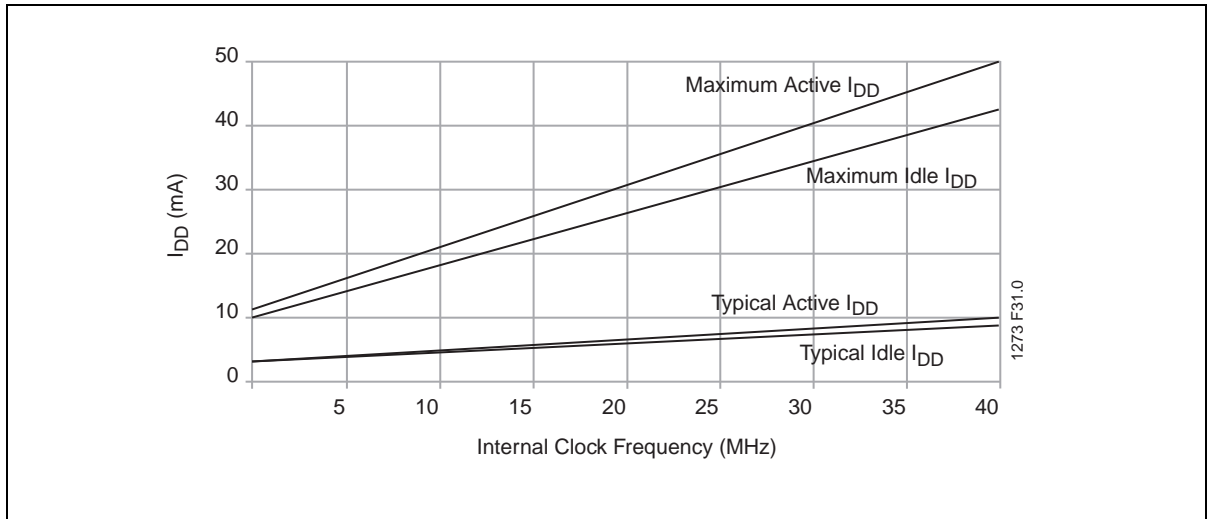

Figure 35: I_{DD} vs. Frequency for 5V SST89E516RDx

AC Electrical Characteristics

AC Characteristics:

(Over Operating Conditions: Load Capacitance for Port 0, ALE#, and PSEN# = 100pF;
 Load Capacitance for All Other Outputs = 80pF)

Table 38: AC Electrical Characteristics (1 of 2)

$T_A = -40^{\circ}\text{C}$ to $+85^{\circ}\text{C}$, $V_{DD} = 2.7\text{-}3.6\text{V}@33\text{MHz}$, $4.5\text{-}5.5\text{V}@40\text{MHz}$, $V_{SS} = 0\text{V}$

Symbol	Parameter	Oscillator						Units
		33 MHz (x1 Mode) 16 MHz (x2 Mode) ¹		40 MHz (x1 Mode) 20 MHz (x2 Mode) ¹		Variable		
		Min	Max	Min	Max	Min	Max	
1/T _{CLCL}	x1 Mode Oscillator Frequency	0	33	0	40	0	40	MHz
1/2T _{CLCL}	x2 Mode Oscillator Frequency	0	16	0	20	0	20	MHz
T _{LHLL}	ALE Pulse Width	46		35		2T _{CLCL} - 15		ns
T _{AVLL}	Address Valid to ALE Low	5				T _{CLCL} - 25 (3V)		ns
				10		T _{CLCL} - 15 (5V)		ns
T _{LLAX}	Address Hold After ALE Low	5				T _{CLCL} - 25 (3V)		ns
				10		T _{CLCL} - 15 (5V)		ns
T _{LLIV}	ALE Low to Valid Instr In		56				4T _{CLCL} - 65 (3V)	ns
					55		4T _{CLCL} - 45 (5V)	ns
T _{LLPL}	ALE Low to PSEN# Low	5				T _{CLCL} - 25 (3V)		ns
				10		T _{CLCL} - 15 (5V)		ns
T _{PLPH}	PSEN# Pulse Width	66		60		3T _{CLCL} - 25 (3V) 3T _{CLCL} - 15 (5V)		ns
			35				3T _{CLCL} - 55 (3V)	ns
T _{PLIV}	PSEN# Low to Valid Instr In				25		3T _{CLCL} - 50 (5V)	ns
						0		ns
T _{PXIZ}	Input Instr Float After PSEN#		25				T _{CLCL} - 5 (3V)	ns
					10		T _{CLCL} - 15 (5V)	ns
T _{PXAV}	PSEN# to Address valid	22		17		T _{CLCL} - 8		ns
T _{AVIV}	Address to Valid Instr In		72				5T _{CLCL} - 80 (3V)	ns
					65		5T _{CLCL} - 60 (5V)	ns
T _{PLAZ}	PSEN# Low to Address Float		10		10		10	ns
T _{RLRH}	RD# Pulse Width	142				6T _{CLCL} - 40 (3V) 6T _{CLCL} - 30 (5V)		ns
				120				ns
T _{WLWH}	Write Pulse Width (WE#)	142		120		6T _{CLCL} - 40 (3V) 6T _{CLCL} - 30 (5V)		ns
T _{RLDV}	RD# Low to Valid Data In		62				5T _{CLCL} - 90 (3V)	ns

Table 38: AC Electrical Characteristics (Continued) (2 of 2)

$T_A = -40^{\circ}\text{C}$ to $+85^{\circ}\text{C}$, $V_{DD} = 2.7\text{-}3.6\text{V}@33\text{MHz}$, $4.5\text{-}5.5\text{V}@40\text{MHz}$, $V_{SS} = 0\text{V}$

Symbol	Parameter	Oscillator						Units
		33 MHz (x1 Mode) 16 MHz (x2 Mode) ¹		40 MHz (x1 Mode) 20 MHz (x2 Mode) ¹		Variable		
		Min	Max	Min	Max	Min	Max	
					75		$5T_{CLCL} - 50$ (5V)	ns
T_{RHDX}	Data Hold After RD#	0		0		0		ns
T_{RHDZ}	Data Float After RD#		36				$2T_{CLCL} - 25$ (3V)	ns
					38		$2T_{CLCL} - 12$ (5V)	ns
T_{LLDV}	ALE Low to Valid Data In		152				$8T_{CLCL} - 90$ (3V)	ns
					150		$8T_{CLCL} - 50$ (5V)	ns
T_{AVDV}	Address to Valid Data In		183				$9T_{CLCL} - 90$ (3V)	ns
					150		$9T_{CLCL} - 75$ (5V)	ns
T_{LLWL}	ALE Low to RD# or WR# Low	66	116	60	90	$3T_{CLCL} - 25$ (3V) $3T_{CLCL} - 15$ (5V)	$3T_{CLCL} + 25$ (3V) $3T_{CLCL} + 15$ (5V)	ns
T_{AVWL}	Address to RD# or WR# Low	46				$4T_{CLCL} - 75$ (3V)		ns
				70		$4T_{CLCL} - 30$ (5V)		ns
T_{WHQX}	Data Hold After WR#	3				$T_{CLCL} - 27$ (3V)		ns
				5		$T_{CLCL} - 20$ (5V)		ns
T_{QVWH}	Data Valid to WR# High	142				$7T_{CLCL} - 70$ (3V)		ns
				125		$7T_{CLCL} - 50$ (5V)		ns
T_{QVWX}	Data Valid to WR# High to Low Transition	10		5		$T_{CLCL} - 20$		ns
T_{RLAZ}	RD# Low to Address Float		0		0		0	ns
T_{WHLH}	RD# to WR# High to ALE High	5	55			$T_{CLCL} - 25$ (3V)	$T_{CLCL} + 25$ (3V)	ns
				10	40	$T_{CLCL} - 15$ (5V)	$T_{CLCL} + 15$ (5V)	ns

1. Calculated values are for x1 Mode only

T0-0.0 25093

Explanation of Symbols

Each timing symbol has 5 characters. The first character is always a 'T' (stands for time). The other characters, depending on their positions, stand for the name of a signal or the logical status of that signal. The following is a list of all the characters and what they stand for.

A: Address	Q: Output data
C: Clock	R: RD# signal
D: Input data	T: Time
H: Logic level HIGH	V: Valid
I: Instruction (program memory contents)	W: WR# signal
L: Logic level LOW or ALE	X: No longer a valid logic level
P: PSEN#	Z: High Impedance (Float)

For example:

T_{AVLL} = Time from Address Valid to ALE Low

T_{LLPL} = Time from ALE Low to PSEN# Low

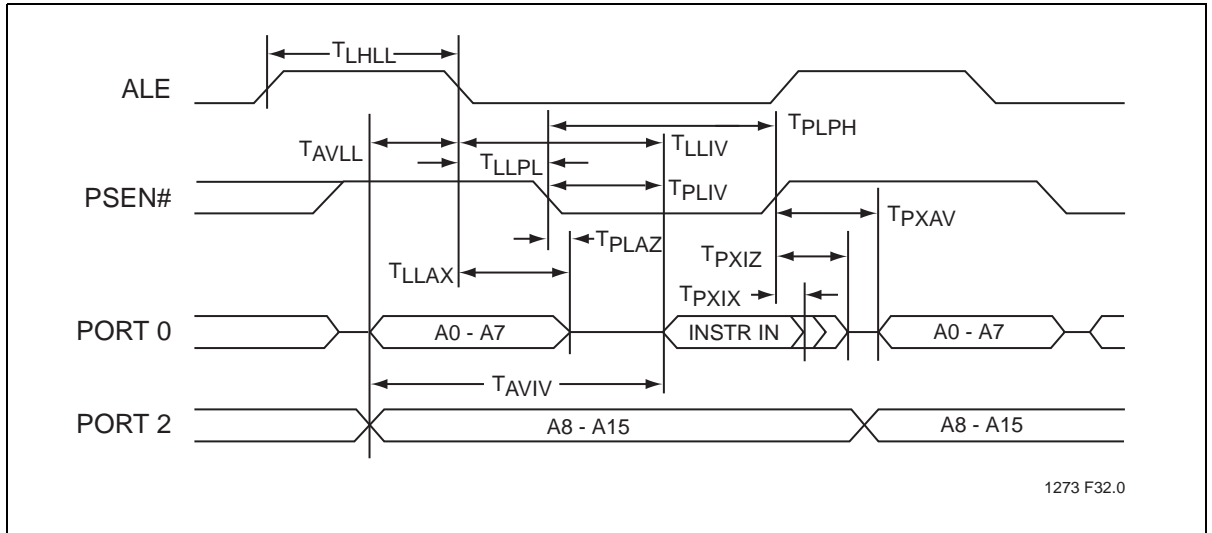

Figure 36: External Program Memory Read Cycle

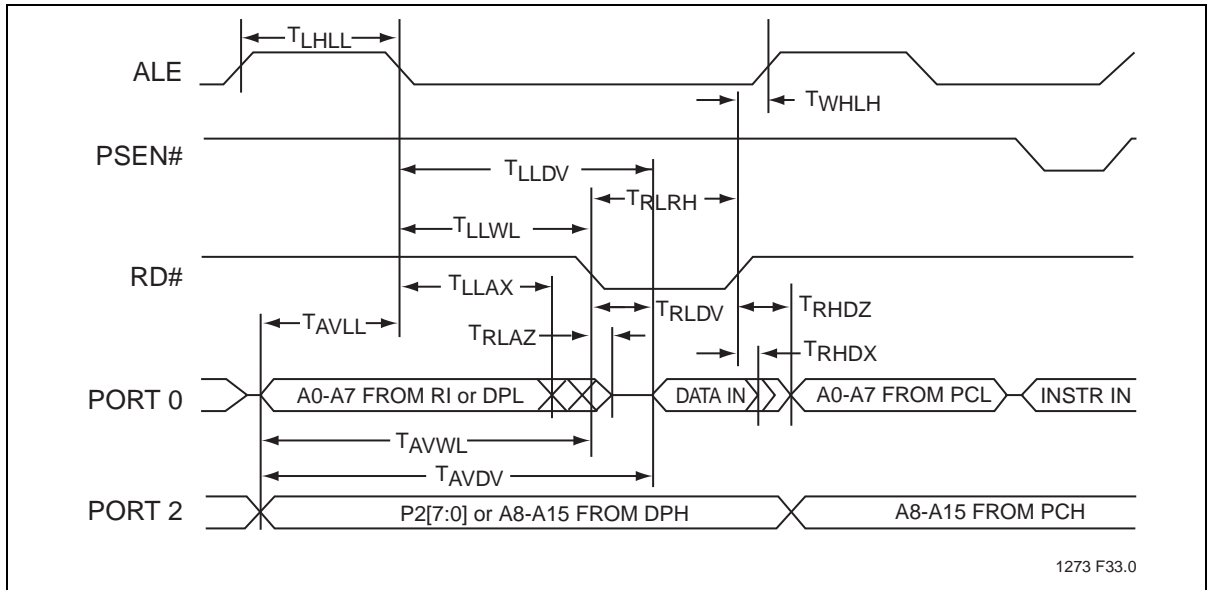

Figure 37: External Data Memory Read Cycle

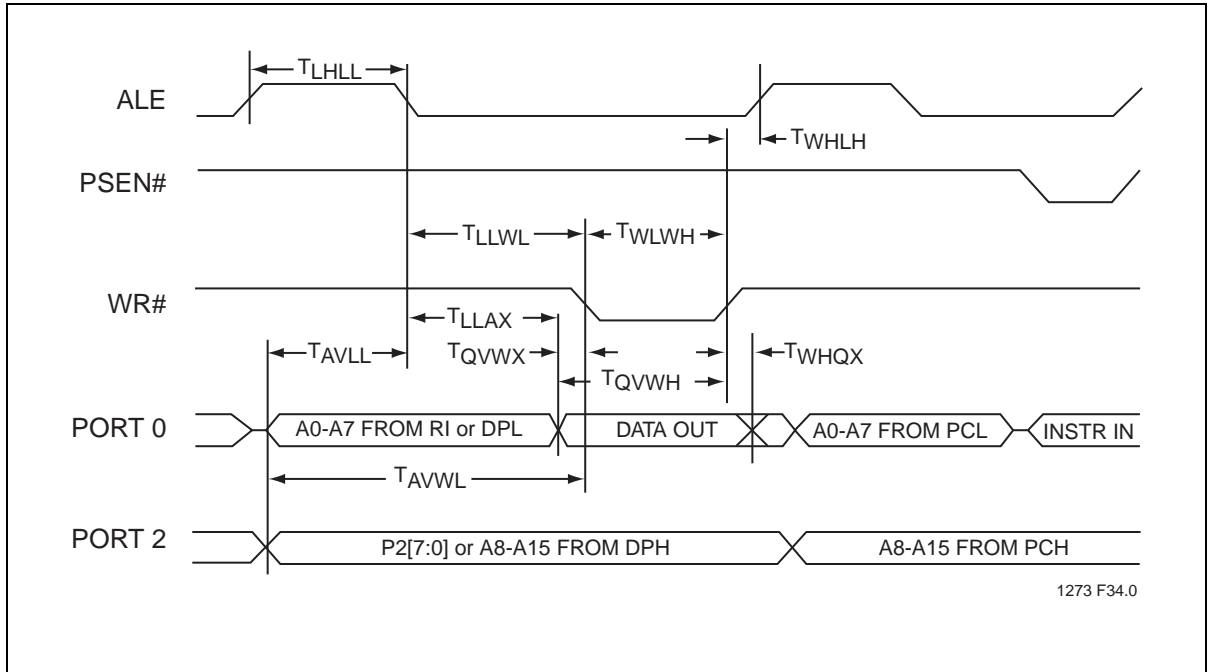

Figure 38: External Data Memory Write Cycle

Table 39: External Clock Drive

Symbol	Parameter	Oscillator						Units
		12MHz		40MHz		Variable		
		Min	Max	Min	Max	Min	Max	
$1/T_{CLCL}$	Oscillator Frequency					0	40	MHz
T_{CLCL}		83		25				ns
T_{CHCX}	High Time			8.75		$0.35T_{CLCL}$	$0.65T_{CLCL}$	ns
T_{CLCX}	Low Time			8.75		$0.35T_{CLCL}$	$0.65T_{CLCL}$	ns
T_{CLCH}	Rise Time		20		10			ns
T_{CHCL}	Fall Time		20		10			ns

TO-0.0 25093

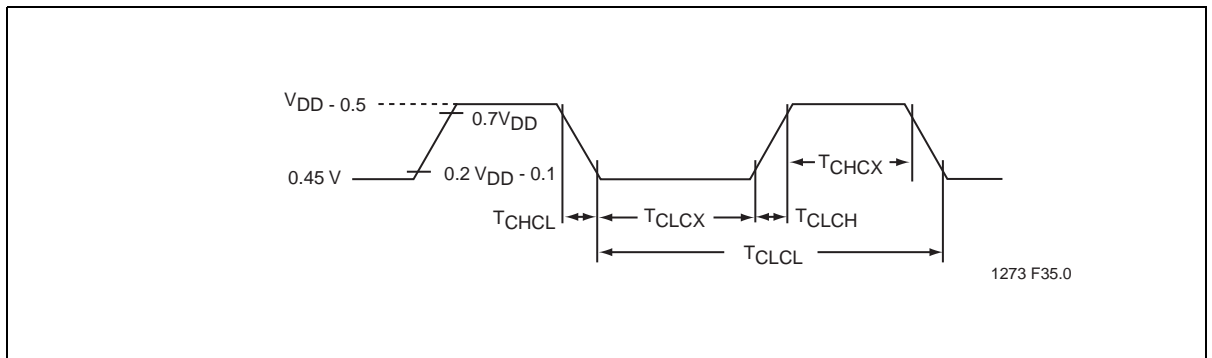
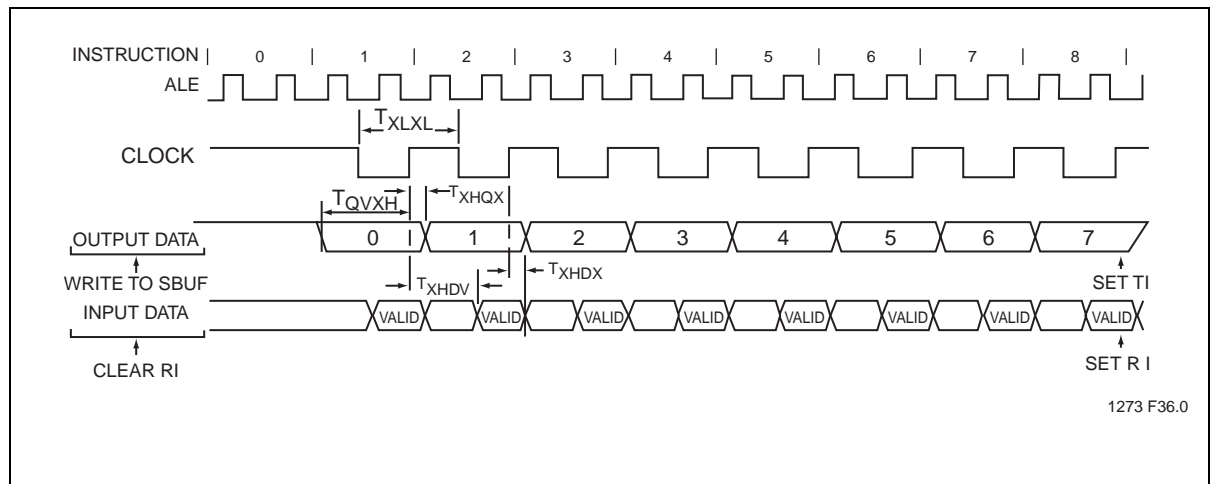

Figure 39: External Clock Drive Waveform

Table 40: Serial Port Timing

Symbol	Parameter	Oscillator						Units
		12MHz		40MHz		Variable		
		Min	Max	Min	Max	Min	Max	
T _{XLXL}	Serial Port Clock Cycle Time	1.0		0.3		12T _{CLCL}		μs
T _{QVXH}	Output Data Setup to Clock Rising Edge	700		117		10T _{CLCL} - 133		ns
T _{XHQX}	Output Data Hold After Clock Rising Edge	50				2T _{CLCL} - 117		ns
				0		2T _{CLCL} - 50		ns
T _{XHDX}	Input Data Hold After Clock Rising Edge	0		0		0		ns
T _{XHDV}	Clock Rising Edge to Input Data Valid		700		117		10T _{CLCL} - 133	ns

TO-0.0 25093



1273 F36.0

Figure 40: Shift Register Mode Timing Waveforms

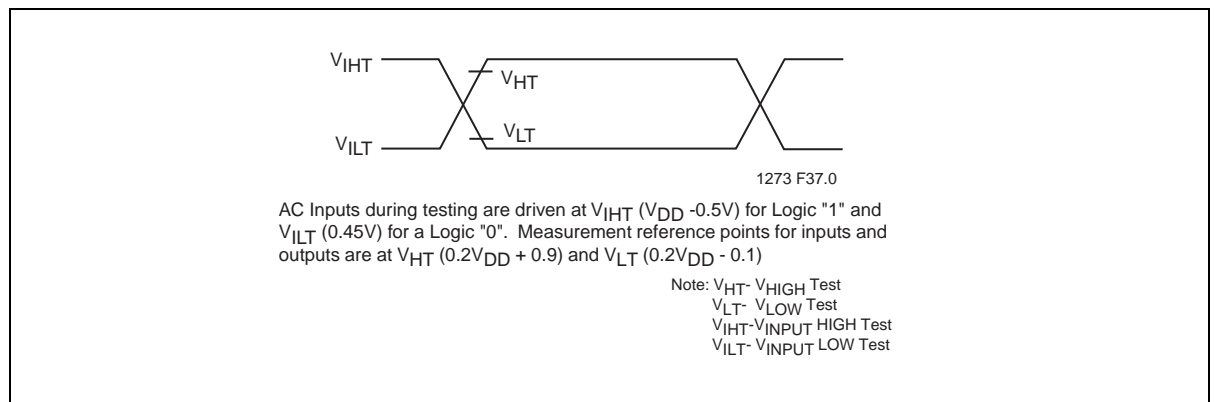

Figure 41: AC Testing Input/Output Test Waveform

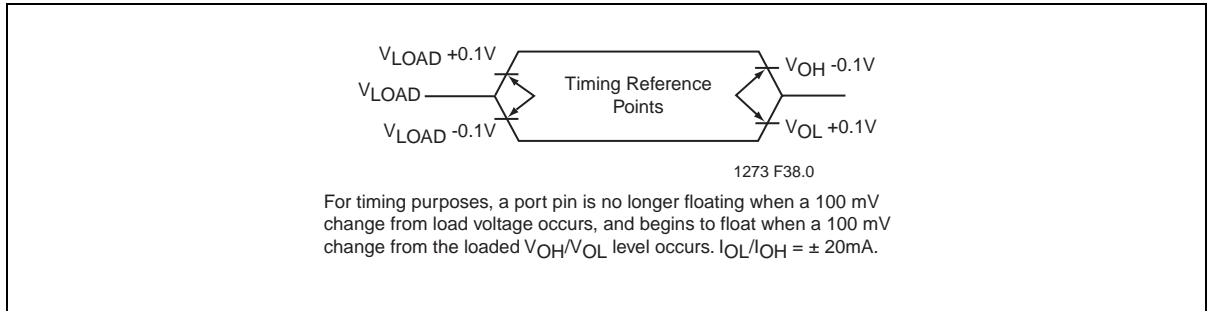

Figure 42: Float Waveform

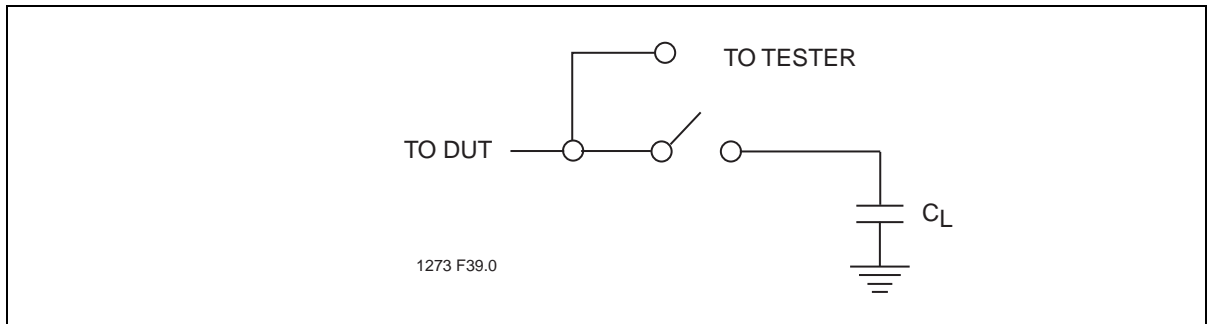

Figure 43: A Test Load Example

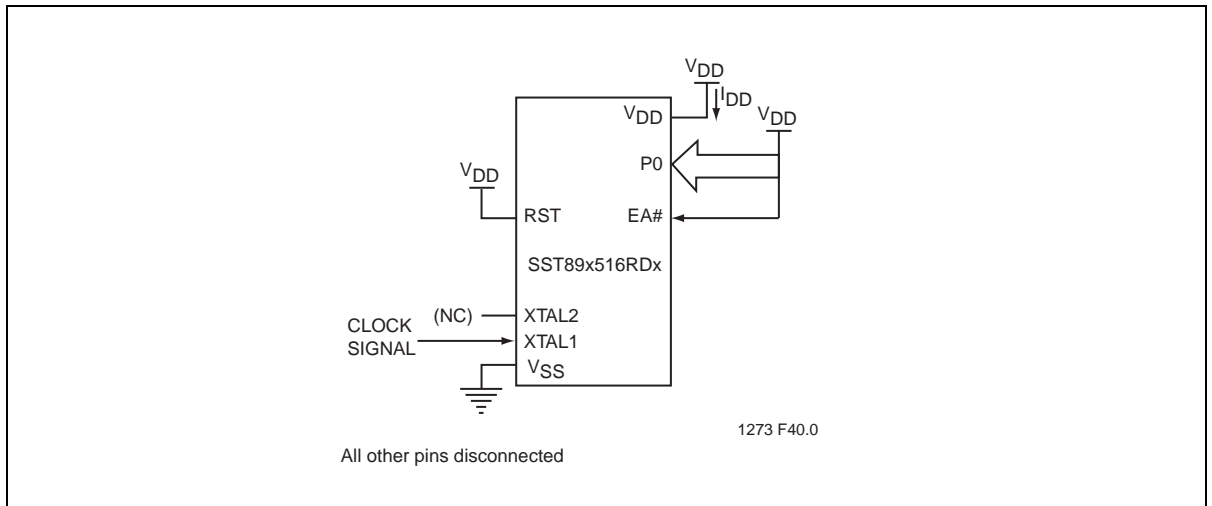

Figure 44: I_{DD} Test Condition, Active Mode

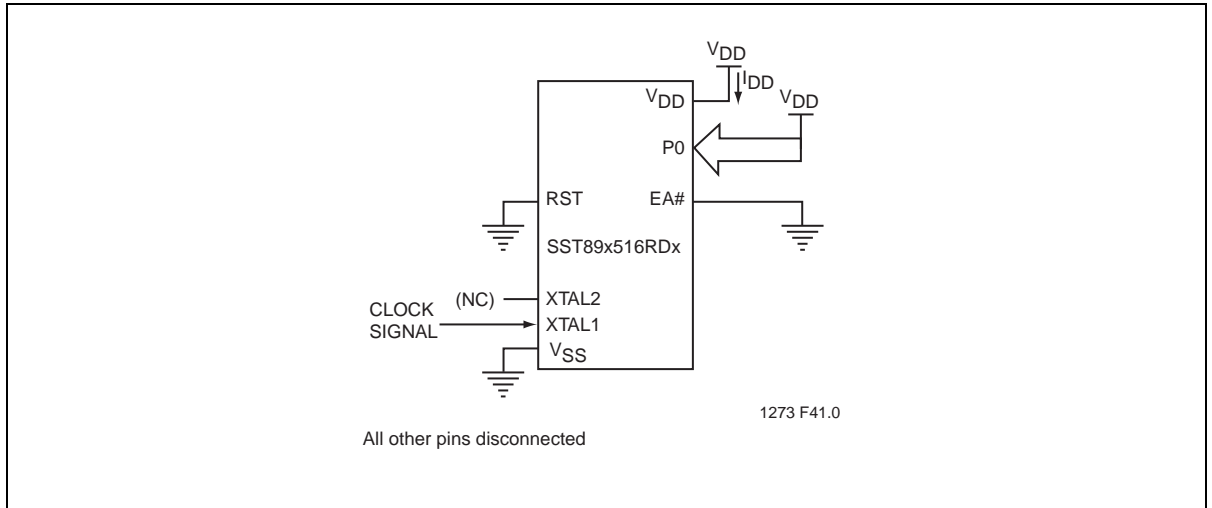

Figure 45: I_{DD} Test Condition, Idle Mode

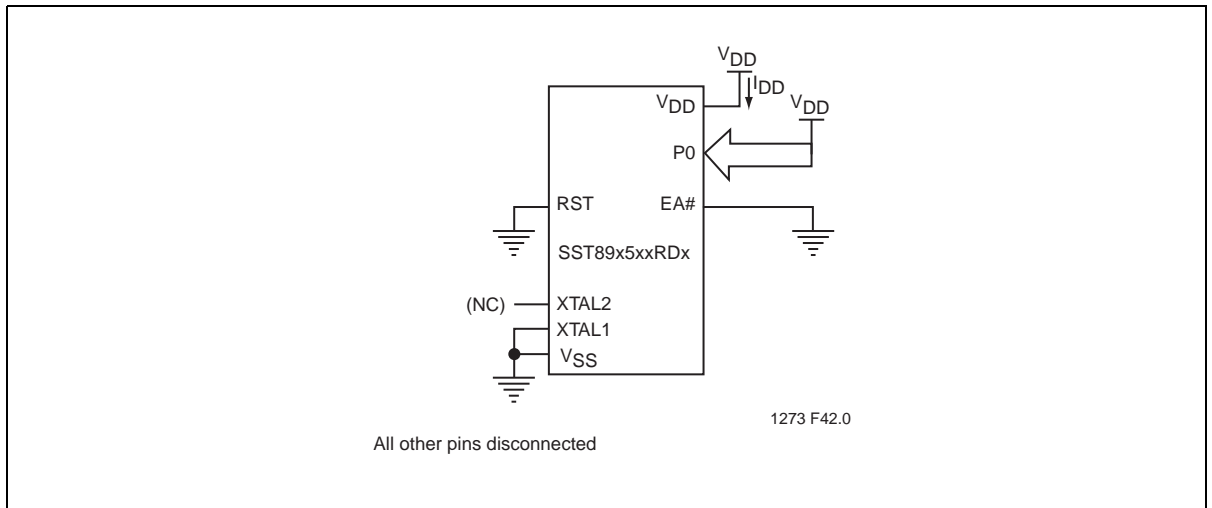

Figure 46: I_{DD} Test Condition, Power-down Mode

Table 41: Flash Memory Programming/Verification Parameters¹

Parameter ²	Max	Units
Chip-Erase Time	150	ms
Block-Erase Time	100	ms
Sector-Erase Time	30	ms
Byte-Program Time ³	50	μ s
Select-Block Program Time	500	ns
Re-map or Security bit Program Time	80	μ s

T0-0.1 25093

1. For IAP operations, the program execution overhead must be added to the above timing parameters.
2. Program and Erase times will scale inversely proportional to programming clock frequency.
3. Each byte must be erased before programming.

Product Ordering Information

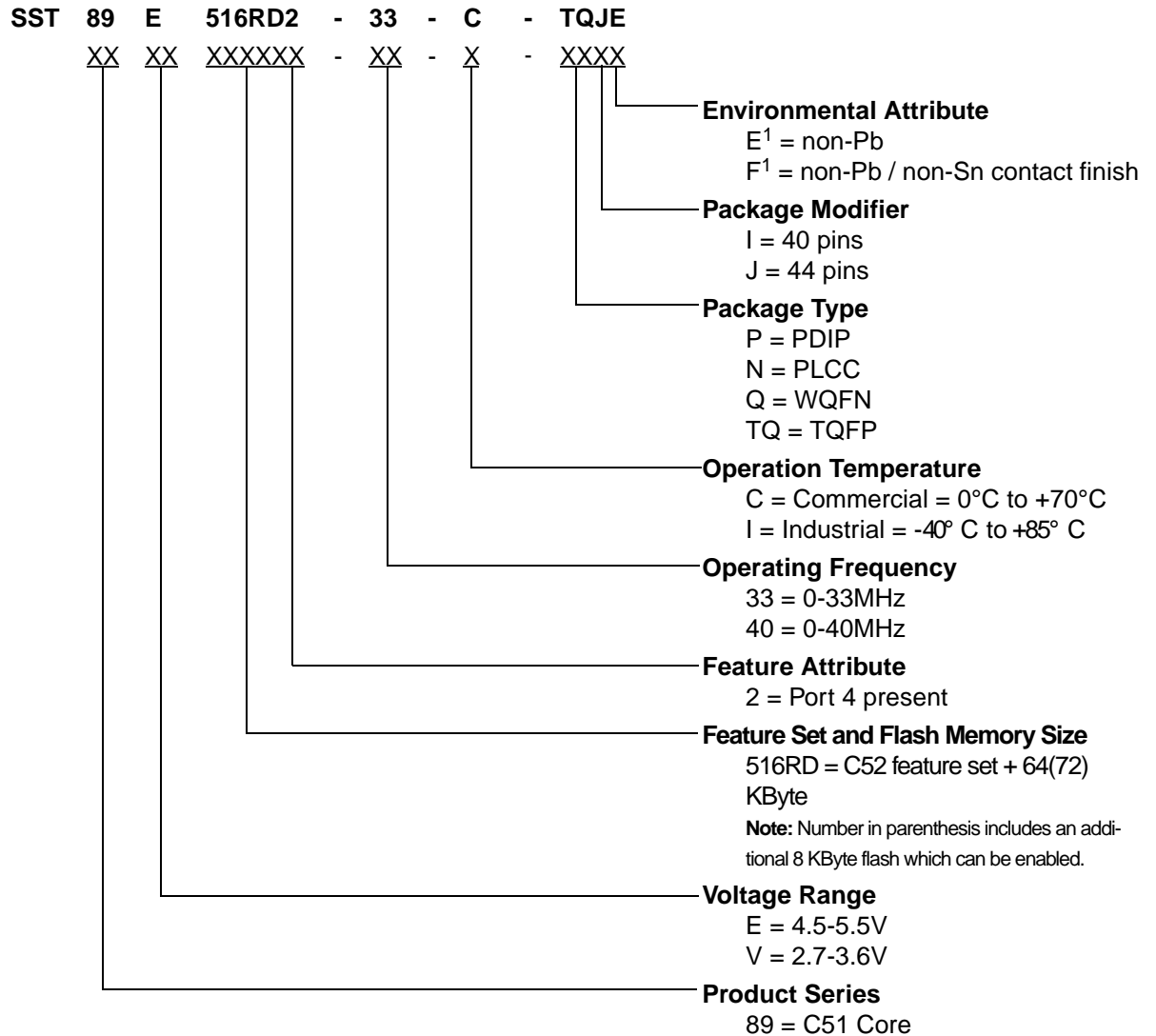

1. Environmental suffix "E" denotes non-Pb solder. Environmental suffix "F" denote non-Pb /non-Sn solder. SST non-Pb / non-Sn solder devices are "RoHS Compliant".

Valid Combinations**Valid combinations for SST89E516RD2**

SST89E516RD2-40-C-NJE SST89E516RD2-40-C-TQJE

SST89E516RD2-40-I-NJE SST89E516RD2-40-I-TQJE

Valid combinations for SST89V516RD2

SST89V516RD2-33-C-NJE SST89V516RD2-33-C-TQJE

SST89V516RD2-33-I-NJE SST89V516RD2-33-I-TQJE

Valid combinations for SST89E516RD

SST89E516RD-40-C-PIE SST89E516RD-40-C-QIF

SST89E516RD-40-I-QIF

Valid combinations for SST89V516RD

SST89V516RD-33-C-PIE SST89V516RD-33-C-QIF

SST89V516RD-33-I-QIF

Note: Valid combinations are those products in mass production or will be in mass production. Consult your SST sales representative to confirm availability of valid combinations and to determine availability of new combinations.

Packaging Diagrams

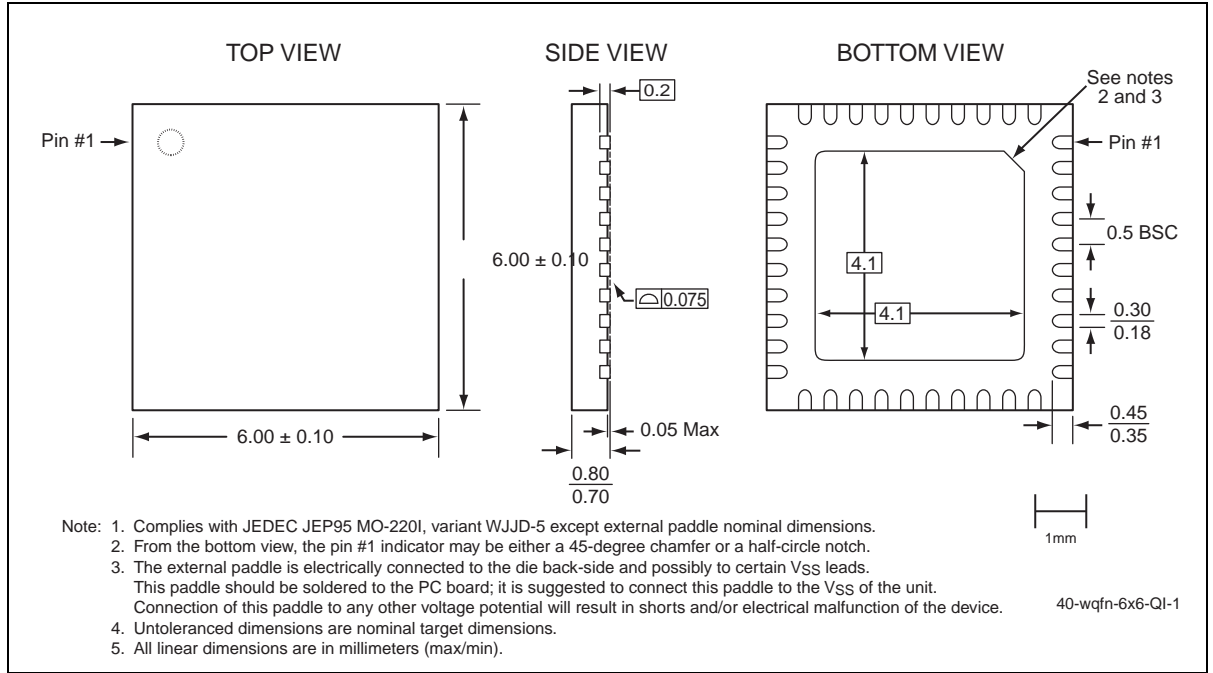

Figure 47:40-contact Very-very-thin Quad Flat No-lead (WQFN)
 SST Package Code: QI

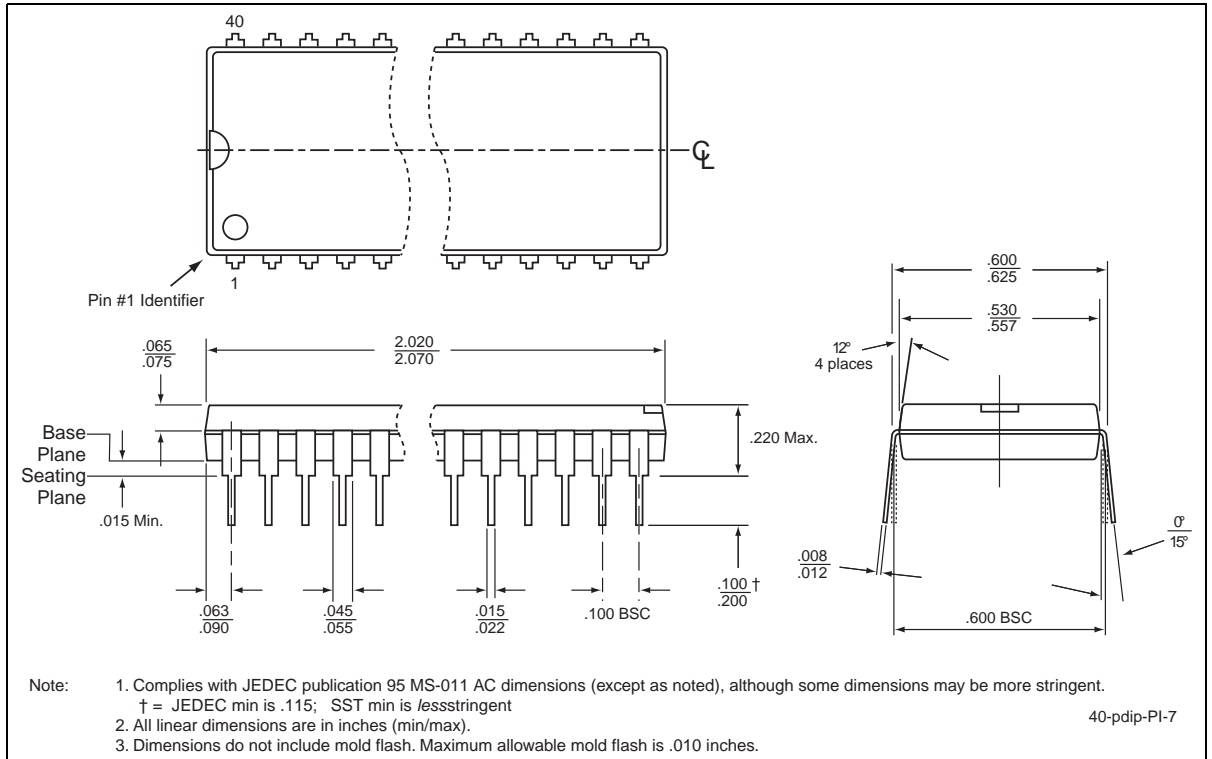

Figure 48: 40-pin Plastic Dual In-line Pins (PDIP)
 SST Package Code: PI

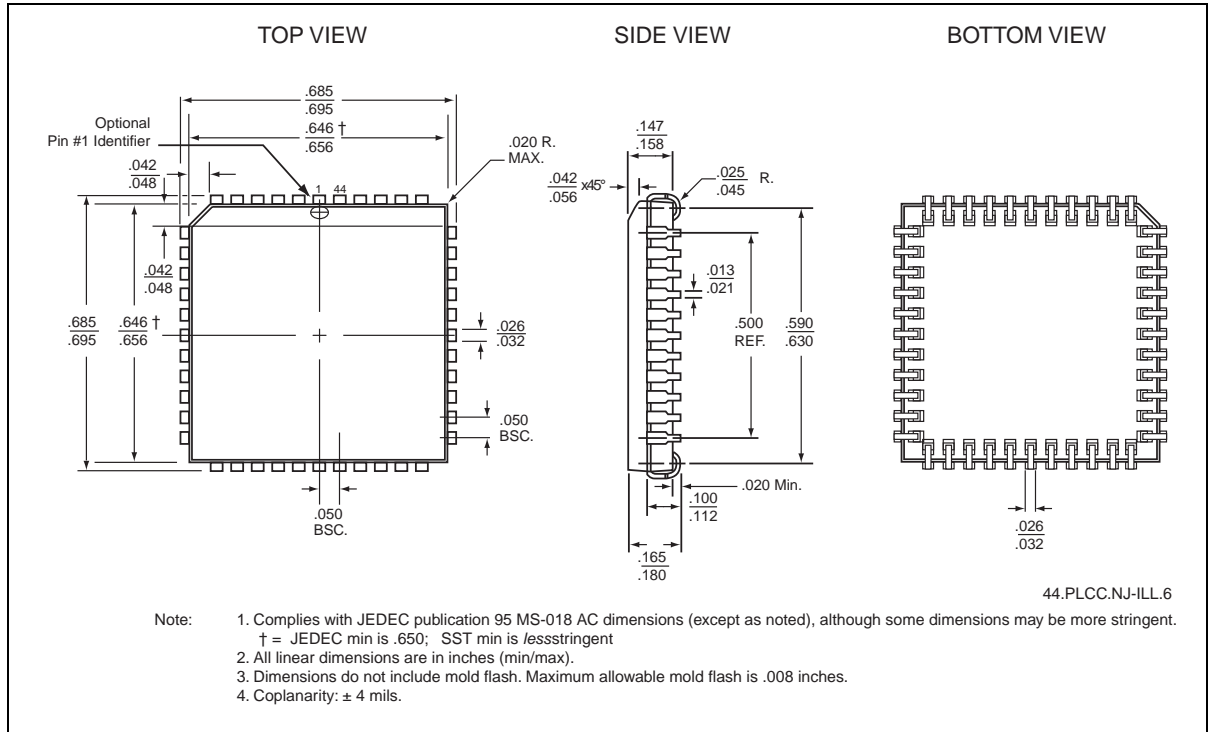

Figure 49:44-lead Plastic Lead Chip Carrier (PLCC)
 SST Package Code: NJ

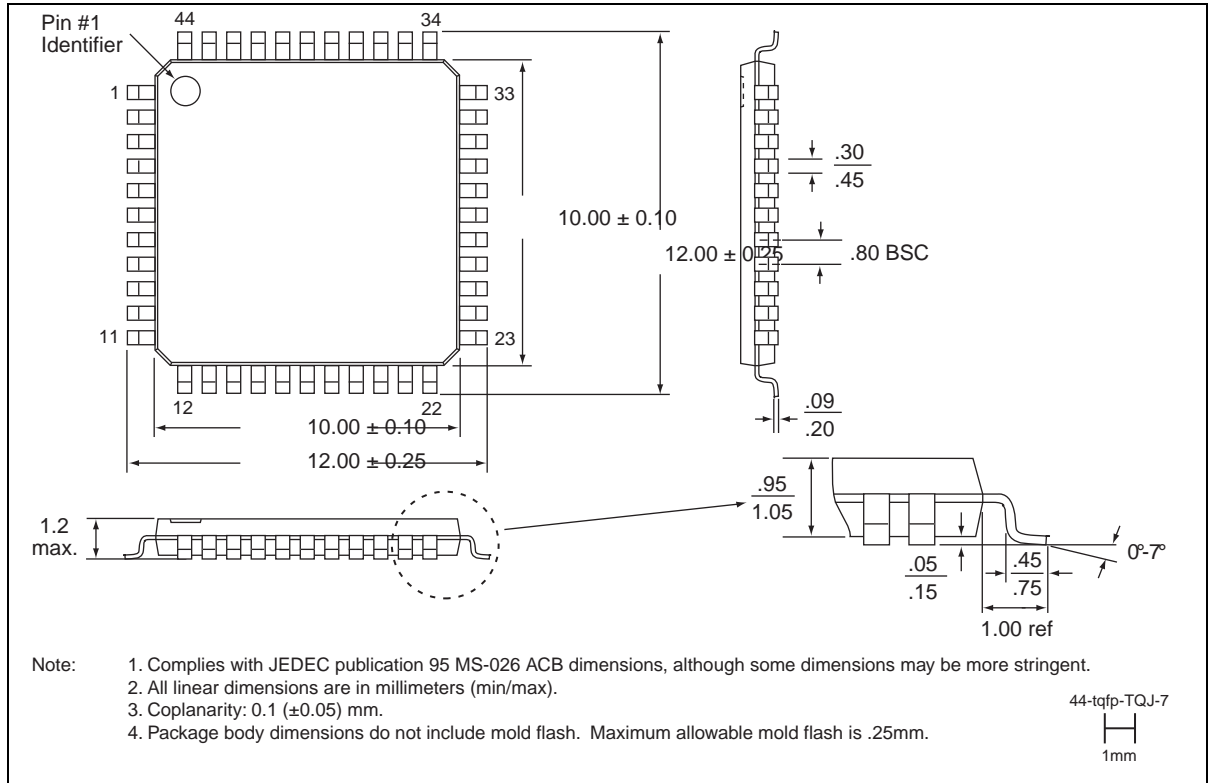

Figure 50:44-lead Thin Quad Flat Pack (TQFP)
 SST Package Code: TQJ

Table 42: Revision History

Revision	Description	Date
00	<ul style="list-style-type: none"> Initial Release of S71273 data sheet. SST89E/V516RD2 devices were previously released in S71255-00-000 S71273 and S71273(01): Added 40-WQFN (QI) package and associated MPNs Added SST89E/V516RD PDIP devices and associated MPNs Clarified the solder temperature profile under “Absolute Maximum Stress Ratings” on page 73 Added RoHS compliance information on page 1 and in the “Product Ordering Information” on page 88 Removed references to External Host Mode programming Corrected MPN breakdown definition for “2” to read “Port 4 present” Corrected the SPI control Register definition for CPHA on page 30 	Mar 2005
01	<ul style="list-style-type: none"> Status change from Preliminary Specifications to Data sheet 	Mar 2005
02	<ul style="list-style-type: none"> Removed NJ, TQJ, and PI from Valid Combinations on page 78 Removed valid combination SST89E516RD-40-I-PIE and SST89V516RD-33-I-PIE on page 78 	Oct 2006
03	<ul style="list-style-type: none"> Replaced FlashFlex51 with FlashFlex globally 	Jan 2007
A	<ul style="list-style-type: none"> Applied new document format Released document under letter revision system Updated spec number from S71273 to DS25093 	Nov 2011
B	<ul style="list-style-type: none"> Removed “Not recommended for new designs” statement on page 1. 	Feb 2013

ISBN: 978-1-62076-989-8

© 2013 Silicon Storage Technology, Inc—a Microchip Technology Company. All rights reserved.

SST, Silicon Storage Technology, the SST logo, SuperFlash, MTP, and FlashFlex are registered trademarks of Silicon Storage Technology, Inc. MPF, SQI, Serial Quad I/O, and Z-Scale are trademarks of Silicon Storage Technology, Inc. All other trademarks and registered trademarks mentioned herein are the property of their respective owners.

Specifications are subject to change without notice. Refer to www.microchip.com for the most recent documentation. For the most current package drawings, please see the Packaging Specification located at <http://www.microchip.com/packaging>.

Memory sizes denote raw storage capacity; actual usable capacity may be less.

SST makes no warranty for the use of its products other than those expressly contained in the Standard Terms and Conditions of Sale.

For sales office locations and information, please see www.microchip.com.

Silicon Storage Technology, Inc.
A Microchip Technology Company
www.microchip.com
