

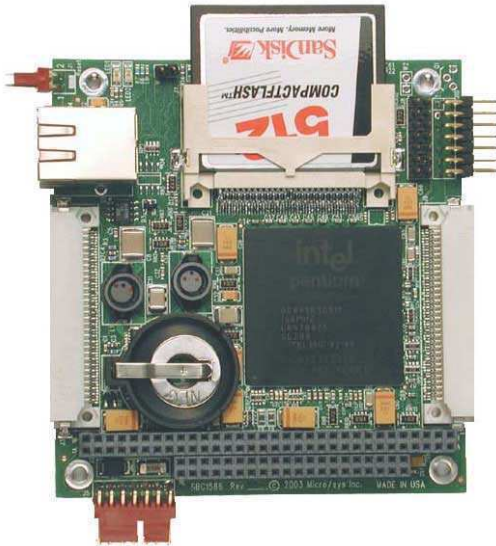

Pentium PC/104 Computer with CompactFlash SBC1586



Features

- ✓ Compact PC/104 footprint
- ✓ Low-Power Pentium, 166 or 266MHz
- ✓ Up to 256MB SDRAM
- ✓ CompactFlash connector
- ✓ Four serial ports
- ✓ One USB port
- ✓ 10/100BASE-T Ethernet
- ✓ PC/104 expansion
- ✓ DOS, Linux, CE, NT, VxWorks®, RTOS

The SBC1586 packs a fast Pentium processor with plenty of memory, and copious amounts of storage into a PC/104-sized board.

With 1MB of on-board flash, accessible as a read/write disk, and up to 256MB of DRAM, many large programs can be run. However, if additional storage capacity is required, the CompactFlash connector allows hundreds of megabytes of removable program and data storage. External IDE drives and floppy drives can also be connected when necessary.

Four serial ports, 10/100BASE-T Ethernet, a printer port, a USB port, an infrared (IrDA) port, three counter/timers, and a watchdog timer mean that the SBC1586 will not require any additional I/O for many applications. However, if additional capabilities are needed, PC/104 expansion allows a wide variety of I/O cards to be stacked on the SBC1586.

Software Support

*DOS emulation
MSDOS 5.0
Linux, CE, NT, VxWorks®
RTOS
Comm Library, CommBLOK™
PID loop library, PidBLOK™
C, compilers
[Items above in Section 6]*

Compatible Hardware

*PC/104 expansion cards
[Items above in Section 4]
RS232/RS485 devices
Custom*

Mounting/Packaging

*Standoffs, STDOFF01
[Items above in Section 5]
Custom*

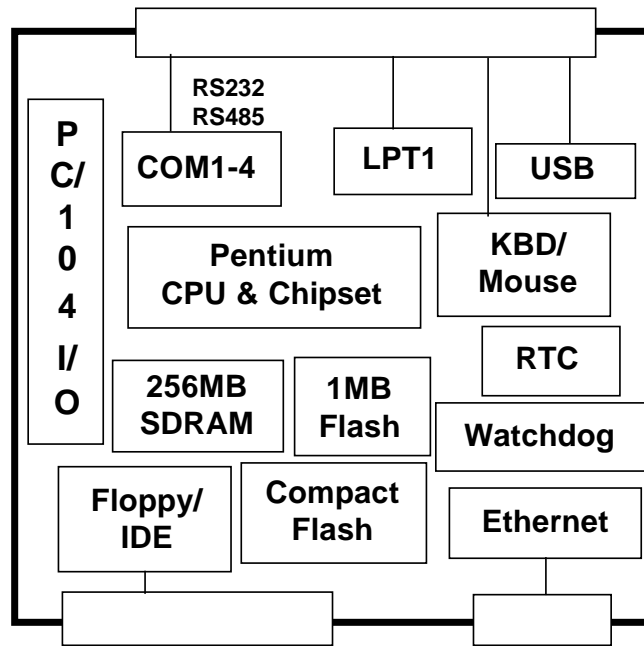

Technical Details:

At the core of the SBC1586 is an Intel Pentium “Tillamook” processor, running at 166 or 266 MHz. The Pentium allows compatibility with both real mode and 32-bit protected mode programs and also integrates a hardware floating point coprocessor.

The Pentium processor is paired with an Intel 430TX chipset. The chipset contains many PC devices, such as a PCI and ISA (PC/104) bus controller, DRAM controller, and USB controller.

The memory subsystem on the SBC1586 allows many programs to be run without any external storage. Up to 256 Mbytes of synchronous DRAM (SDRAM) is more than sufficient for many complex, protected-mode programs and operating systems.

The 1-Mbyte Flash memory chip contains both the BIOS and a user application code space. The user space can be configured as a 768k read/write flash disk.

If a larger program or data storage space is required, or if removability is needed, the CompactFlash interface can provide hundreds of megabytes of storage.

Four serial ports allow communication with many different devices. COM1 through COM4 are 16C550-compatible UARTs (with transmit and receive FIFOs). All four serial ports are capable of speeds up to 115200 baud, have RS-232 transceivers, and have RTS and CTS modem control lines. Additionally, COM4 can be configurable for full-duplex RS-485 communication with jumperable termination resistors.

The PC/104 connector provides support for both 8-bit and 16-bit expansion boards and operates with standard PC/104 bus protocol and timing. The default configuration is non-stackthrough connectors, allowing the SBC1586 to be the bottom card in a stack. The stackthrough option (SBCOPT16ST) allows the SBC1586 to be plugged into a custom-designed OEM I/O board as an automation component.

The SBC1586 can support application development under numerous strategies. If 16-bit DOS or DOS-extended software is sufficient, Micro/sys offers a free DOS-compatible operating system preinstalled on the SBC1586. For a small royalty fee, true MSDOS 5.0 can be preinstalled. Powerful, cost-effective remote debug capabilities are provided through Borland's Turbo Debugger.

For true 32-bit application development, the SBC1586 supports a number of alternatives. Due to its PC compatibility, 32-bit real time operating systems (RTOS) such as Linux, PharLap® ETS, and VxWorks® can be booted on the SBC1586. All support 32-bit linear protected mode operation, and have full tool suites available, including compilers and debuggers.

For pre-configured sets of options, Micro/sys can provide OEMs with a single part number for ordering. In addition, custom versions of the SBC1586 are available. Please call Micro/sys Technical Sales for details.

Specifications:

Mechanical:

- ❑ PC/104 standard (3.55" x 3.775" x .6") except SDRAM DIMM on bottom side has height of .22" and Ethernet connector on top side has height of .535".

Power Requirements:

- ❑ SBC1586: +5v ±5% at 3.7A max
- ❑ SBC1586-ET: +5v ±5% at 3.0A max
- ❑ +12v required only if used by PC/104 modules

Environmental:

Part number	Board Airflow*	Operating Temp
SBC1586	29 cfm	0° to +64°C
SBC1586-ET	0 lfpm	-40° to +65°C
SBC1586-ET	4.8 cfm	-40° to +70°C
SBC1586-ET	9.6 cfm	-40° to +85°C

*Using 80mm fan

- ❑ -40° to +85°C storage
- ❑ 5%-95% relative humidity, non-condensing

Processor Core Section:

- ❑ Intel Low-Power Embedded Pentium
- ❑ 266 MHz (SBC1586) or 166 MHz (SBC1586-ET) clock rate

On-board Memory:

- ❑ 64M SDRAM based at 0, expandable to 256M
- ❑ 1M of Flash at top of memory map with BIOS and operating system installed; 768K available for user application
- ❑ BIOS setup stored in 2Kbyte EEPROM

COM1-COM4 Serial Ports:

- ❑ Four async serial ports, PC compatible
- ❑ COM1-COM4 16550-compatible
- ❑ RTS and CTS modem controls
- ❑ RS232 on all four channels
- ❑ COM4 RS485 full duplex

Serial Port Connector			
Pin	Signal	Signal	Pin
1	RX COM1	RTS COM1	2
3	TX COM1	CTS COM1	4
5	N/C	N/C	6
7	GND	RX COM2	8
9	RTS COM2	TX COM2	10
11	CTS COM2	N/C	12
13	N/C	GND	14

Parallel Printer Port:

- Bi-directional LPT standard

Keyboard, Mouse, and Speaker:

- PS/2-compatible keyboard port
- PS/2-style mouse port
- AT-compatible TTL speaker port

USB:

- USB 1.0 port
- Transfers at 12 or 1.5 Mbit/sec

Floppy Disk Interface:

- Two drives on single cable
- Standard connector pinout on breakout board

IDE:

- Two drives on single cable (CompactFlash counts as one drive)
- Standard 40-pin connector pinout on breakout board
- Hard drive, CD-ROM support
- Flexible BIOS drive setup

Watchdog Timer:

- Program must refresh watchdog timer every 1.6 seconds, or board reset will be issued
- Enabled through software

Real Time Clock:

- RTC with on-board battery
- Driver code in BIOS

PC/104 Interface:

- 8-bit and 16-bit PC/104 module support
- Full IRQ and DRQ support
- Standard mounting holes
- Stackthrough option available

CompactFlash Interface:

- Supports Type I CompactFlash
- Operates in True IDE mode
- CF+ cards not supported
- Not hot-swappable

Main I/O Connector			
Pin	Signal	Signal	Pin
1	GND	RX COM3	2
3	TX+ COM4 RS485	RTS COM3	4
5	TX- COM4 RS485	TX COM3	6
7	RX+ COM4 RS485	CTS COM3	8
9	RX- COM4 RS485	N/C	10
11	N/C	N/C	12
13	N/C	GND	14
15	GND	RX COM4	16
17	LTP STB#	RTS COM4	18
19	LTP ALF#	TX COM4	20
21	LPT D0	CTS COM4	22
23	LPT ERR#	N/C	24
25	LPT D1	N/C	26
27	LPT INIT#	GND	28
29	LPT D2	GND	30
31	LPT SLCTIN#	GND	32
33	LPT 3D	Mouse Clk	34
35	GND	Mouse Data	36
37	LPT D4	+5V	38
39	LPT D5	+5V	40
41	LPT D6	Kbd Data	42
43	LPT D7	Kbd Clk	44
45	LPT ACK#	Speaker	46
47	GND	+5V	48
49	LPT BUSY#	IrDA Tx	50
51	LPT PE	GND	52
53	LPT SLCT	IrDA Rx	54
55	PBRESET#	GND	56
57	+5V	USB +	58
59	IDE Active	USB -	60

DK1586 Development Kit:

- Free with first SBC1586 purchase
- Breakout cables to COM1-COM4
- Download cable and utilities
- Power cable pigtail
- Documentation, schematics, sample software

External Connections:

- ❑ 14-pin header for COM1-COM2
- ❑ 60-pin high-density connector for COM3-COM4, LPT1, keyboard, mouse, IrDA
- ❑ 60-pin high-density connector for IDE, floppy
- ❑ 7-pin locking header for power input
- ❑ 2-pin locking header for pushbutton reset

Disk I/O Connector			
Pin	Signal	Signal	Pin
1	IDE RESET#	GND	2
3	GND	IDE D8	4
5	IDE D7	IDE D9	6
7	IDE D6	IDE D10	8
9	IDE D5	IDE D11	10
11	IDE D4	IDE D12	12
13	IDE D3	IDE D13	14
15	IDE D2	IDE D14	16
17	IDE D1	IDE D15	18
19	IDE D0	GND	20
21	GND	IDE IOW#	22
23	IDE IOR#	IDE DRQ	24
25	IDE IORDY	IDE IRQ	26
27	IDE CSEL1	IDE D0	28
29	IDE DACK#	IDE A1	30
31	IDE DIAG#	IDE A2	32
33	IDE CS1#	IDE DASP#	34
35	IDE CS3#	GND	36
37	GND	FLPY WDATA#	38
39	FLPY	FLPY INDEX#	40
41	FLPY MOTEB#	FLPY DSKCHG#s	42
43	FLPY DRVSA#	FLPY SIDE#	44
45	FLPY DRVSB#	FLPY WPT#	46
47	FLPY MOTEA#	FLPY TRKO#	48
49	GND	FLPY WGATE#	50
51	N/C	FLPY STEP#	52
53	N/C	FLPY DIR#	54

Power Connector	
Pin	Signal
1	+5V
2	GND
3	GND
4	+12V
5	N/C
6	GND
7	+5V

Ordering Information:

Single Board Computer:

SBC1586	Pentium CPU, 266MHz, 64MB RAM, 1M Flash
SBC1586-1	Pentium CPU, 266MHz, 64MB RAM, 1M Flash, Ethernet
SBC1586-ET	Pentium CPU, 166MHz, 64MB RAM, 1M Flash, -40°C to +85°C operating temp
SBC1586-1-ET	Pentium CPU, 166MHz, 64MB RAM, 1M Flash, Ethernet, -40°C to +85°C operating temp
DK1586	Development kit - firmware, cables, docs
SDK-Linux	Linux kit (requires Ethernet and 1586OPT50)
1586OPT3	128MB RAM total
1586OPT4	256MB RAM total
1586OPT14	COM3/COM4, temperature sensor
1586OPT25	MSDOS 5.0 Bootable A: Flash Disk
1586OPT50	Linux startup kernel installed in flash

Accessories:

CA4089	Breakout cable for COM1-COM2 DB9
CA4094	Power connector pigtail, 18"
CA4095	Breakout cable for COM3-COM4, LPT1, keyboard, mouse

CA4096	Breakout cable for IDE, floppy drives
SBCOPT16ST	Stackthrough PC/104
CF-FL128	128MB CompactFlash Card
CF-FL256	256MB CompactFlash Card
CF-FL512	512MB CompactFlash Card

Cables nominally 15", other lengths available.

CommBLOK, PidBLOK trademark Drumlin

IBM, PC trademark IBM Corp.

MSDOS, Microsoft trademark Microsoft Corp.

Turbo Debugger trademark Borland International

VxWorks trademark Wind River