

## Temperature Switch with Selectable Hysteresis

### Features

- Factory Set Temperature Switch
- Available Temperature Switch Thresholds:
  - $T_{SET} = -35^{\circ}\text{C}, -25^{\circ}\text{C}, -15^{\circ}\text{C}, -5^{\circ}\text{C}, 5^{\circ}\text{C}, 15^{\circ}\text{C}, 25^{\circ}\text{C}, 35^{\circ}\text{C}, 45^{\circ}\text{C}, 55^{\circ}\text{C}, 65^{\circ}\text{C}, 75^{\circ}\text{C}, 85^{\circ}\text{C}, 95^{\circ}\text{C}, 105^{\circ}\text{C}, 115^{\circ}\text{C}, 125^{\circ}\text{C}$
- Wide Operating Voltage Range: 2.7V to 5.5V
- Low Supply Current: 25  $\mu\text{A}$  (typical)
- Temperature Switch Accuracy:
  - $\pm 1^{\circ}\text{C}$  (typical)
  - $\pm 4^{\circ}\text{C}$  (maximum)  $-15^{\circ}\text{C}$  to  $+75^{\circ}\text{C}$
  - $\pm 6^{\circ}\text{C}$  (maximum)  $-40^{\circ}\text{C}$  to  $+125^{\circ}\text{C}$
- Switch Threshold Options (Hot/Cold):
  - Rising Temp.: MCP9501/2 (Hot Option)
  - Falling Temp.: MCP9503/4 (Cold Option)
- Output Configuration Options:
  - Active Low, Open-Drain Output: MCP9501/3
    - Uses External Pull-up Resistor
  - Active-High, Push-Pull Output: MCP9502/4
- User Selectable Hysteresis:  $2^{\circ}\text{C}$  or  $10^{\circ}\text{C}$  (typical)
- 5-lead SOT-23 package

### Applications

- Power Supply Critical Temperature Shutdown
- Temperature Alarm
- Thermostat Control
- Fan Control
- Base-Station
- Automotive

### Typical Performance

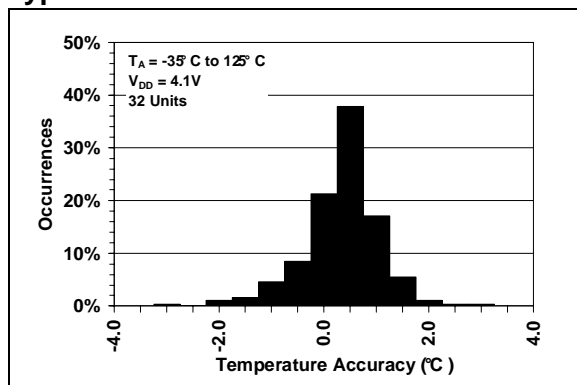

### Description

Microchip Technology's MCP9501/2/3/4 family of devices are temperature switches with  $\pm 1^{\circ}\text{C}$  (typical) accurate factory set output thresholds. These devices are ideal for high power supply systems where an overtemperature protection circuit is needed. These devices do not require external components, consume 25  $\mu\text{A}$  (typical), and the factory set thresholds provide simplicity.

In addition, this family of devices provide user selectable  $2^{\circ}\text{C}$  and  $10^{\circ}\text{C}$  (typical) switch hysteresis, and various output configurations. The MCP9501/2 outputs switch for rising temperatures while the MCP9503/4 switch for falling temperature, with the relative hysteresis at the set thresholds. This family of devices is also available with Active-High Push-Pull and Active-Low Open-Drain outputs, the MCP9502/4 and the MCP9501/3, respectively. The Push-Pull output is ideal for a microcontroller interface while the Open-Drain output can be used for level shifting, wired-OR configuration, or as a heater on/off switch.

The MCP9501/2/3/4 operate from 2.7V to 5.5V supply. This family is available with space saving 5-lead SOT-23 package.

### Package Types



# MCP9501/2/3/4

## OUTPUT FUNCTIONAL DESCRIPTION

### MCP9501, Hot-Option (Open-Drain, Active-Low)

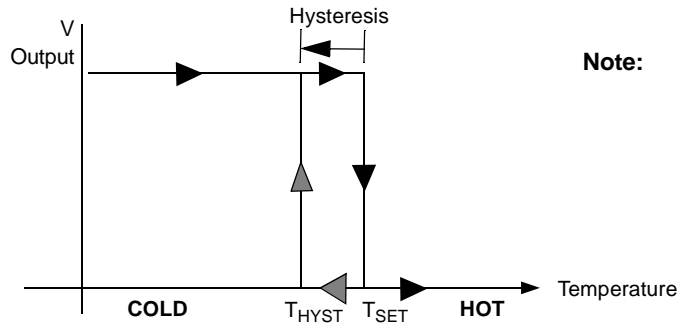

**Note:** Available temperature thresholds for Option P or for rising temperature only: +5°C, +15°C, +25°C, +35°C, +45°C, +55°C, +65°C, +75°C, +85°C, +95°C, +105°C, +115°C, +125°C.

### MCP9502, Hot-Option (Push-Pull, Active-High)

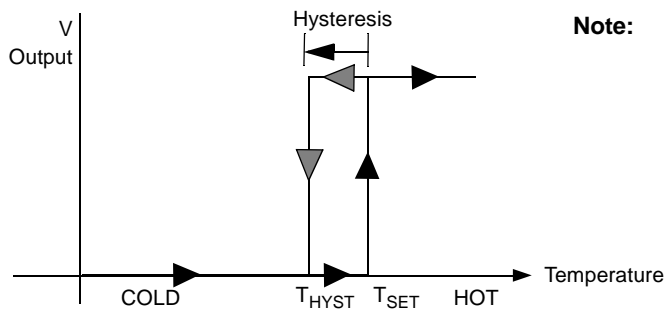

**Note:** Available temperature thresholds for Option P or for rising temperature only: +5°C, +15°C, +25°C, +35°C, +45°C, +55°C, +65°C, +75°C, +85°C, +95°C, +105°C, +115°C, +125°C.

### MCP9503, Cold-Option (Open-Drain, Active-Low)

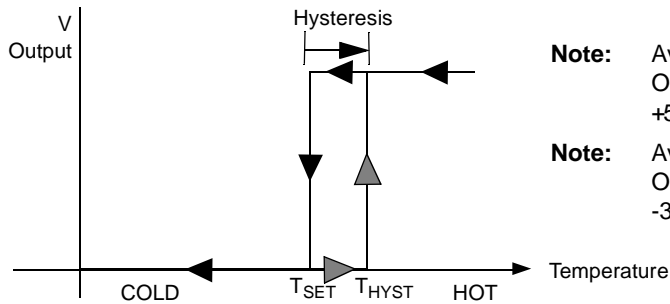

**Note:** Available temperature thresholds for Option P or for rising temperature only: +5°C, +15°C, +25°C.

**Note:** Available temperature thresholds for Option N or for falling temperature only: -35°C, -25°C, -15°C, -5°C.

### MCP9504, Cold-Option (Push-Pull, Active-High)

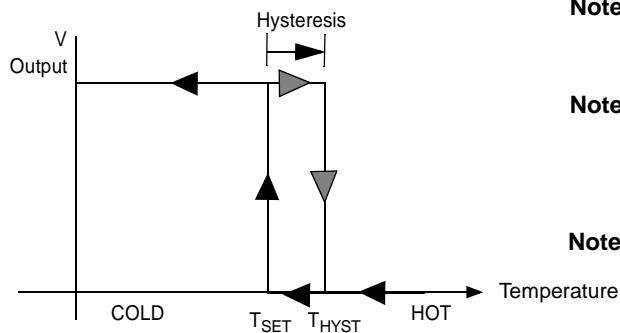

**Note:** Available temperature thresholds for Option P or for rising temperature only: +5°C, +15°C, +25°C.

**Note:** Available temperature thresholds for Option N or for falling temperature only: -35°C, -25°C, -15°C, -5°C.

**Note:** Contact Microchip for all other threshold options.

## 1.0 ELECTRICAL CHARACTERISTICS

Junction Temperature ( $T_J$ ) ..... +150°C  
 ESD protection on all pins (HBM:MM) ..... (4 kV/400V)  
 Latch-Up Current at each pin (25°C) ..... ±200 mA

### Absolute Maximum Ratings †

$V_{DD}$  ..... 6.0V  
 Voltage at all Input/Output pins ..... GND – 0.3V to 6.0V  
 Input/Output Current ..... 20 mA  
 Storage temperature ..... -65° C to +150°C  
 Ambient temp. with power applied ..... -40° C to +125°C

†**Notice:** Stresses above those listed under “Maximum ratings” may cause permanent damage to the device. This is a stress rating only and functional operation of the device at those or any other conditions above those indicated in the operational listings of this specification is not implied. Exposure to maximum rating conditions for extended periods may affect device reliability.

## DC CHARACTERISTICS

**Electrical Specifications:** Unless otherwise indicated,  $V_{DD} = 2.7V$  to  $5.5V$ ,  $T_A = -40^\circ C$  to  $+125^\circ C$ , and GND = Ground.

Parameters	Sym	Min	Typ	Max	Unit	Conditions
<b>Sensor Accuracy</b>						
$-15^\circ C \leq T_A \leq +75^\circ C$		-4	±1	+4	°C	Note 1
$-40^\circ C \leq T_A \leq +125^\circ C$		-6	±2	6	°C	
<b>Power Supply</b>						
Operating Voltage	$V_{DD}$	2.7	—	5.5	V	
Operating Current	$I_{DD}$	—	25	40	µA	
Line-Regulation	$\Delta C / \Delta V$	—	0.2	—	°C/V	$V_{DD} = 2.7V$ to $5.5V$
<b>Hysteresis</b>						
Trip Point Hysteresis	$T_{HYST}$	—	2	—	°C	HYST = GND
		—	10	—	°C	HYST = $V_{DD}$
Hysteresis Select Input	$V_{IH}$	$0.8V_{DD}$	—	—	V	
	$V_{IL}$	—	—	$0.2V_{DD}$	V	
	$I_{Leak}$	—	0.1	—	µA	
Open-Drain Output Leakage	$I_{Leak}$	—	0.1	10	µA	MCP9501/3
Output Voltage High	$V_{OH}$	$0.8V_{DD}$	—	—	V	$I_{OUT} = 5$ mA (MCP9502/4)
Output Voltage Low	$V_{OL}$	—	—	$0.2V_{DD}$	V	$I_{OUT} = 5$ mA
Turn On Time	$T_{ON}$	—	1	—	ms	
SOT23-5	$t_{RES}$	—	1.7	—	s	Time to 63% (89°C). +25° C (Air) to +125°C (oil bath)

**Note 1:** This specification is tested at mid supply of 4.1V for optimum operation across the supply voltage range of 2.7V to 5.5V.

## TEMPERATURE CHARACTERISTICS

**Electrical Specifications:** Unless otherwise indicated,  $V_{DD} = 2.7V$  to  $5.5V$ ,  $T_A = -40^\circ C$  to  $+125^\circ C$ , and GND = Ground.

Parameters	Sym	Min	Typ	Max	Units	Conditions
<b>Temperature Ranges</b>						
Specified Temperature Range	$T_A$	-40	—	+125	°C	(Note 1)
Operating Temperature Range	$T_A$	-40	—	+125	°C	
Storage Temperature Range	$T_A$	-65	—	+150	°C	
<b>Thermal Package Resistances</b>						
Thermal Resistance, 5L-SOT23	$\theta_{JA}$	—	220.7	—	°C/Ω	

**Note 1:** Operation in this range must not cause  $T_J$  to exceed Maximum Junction Temperature (+150°C).

# MCP9501/2/3/4

## 2.0 TYPICAL PERFORMANCE CURVES

**Note:** The graphs and tables provided following this note are a statistical summary based on a limited number of samples and are provided for informational purposes only. The performance characteristics listed herein are not tested or guaranteed. In some graphs or tables, the data presented may be outside the specified operating range (e.g., outside specified power supply range) and therefore outside the warranted range.

**Note:** Unless otherwise indicated,  $V_{DD} = 2.7V$  to  $5.5V$ ,  $T_A = -40^{\circ}C$  to  $+125^{\circ}C$ , GND = Ground,  $R_{PULL-UP} = 10\ k\Omega$  (MCP9501/3 only) and  $0.1\ \mu F$  bypass capacitor.

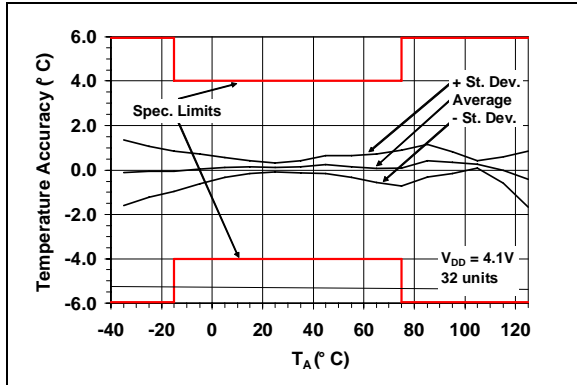

FIGURE 2-1: Temperature Accuracy.

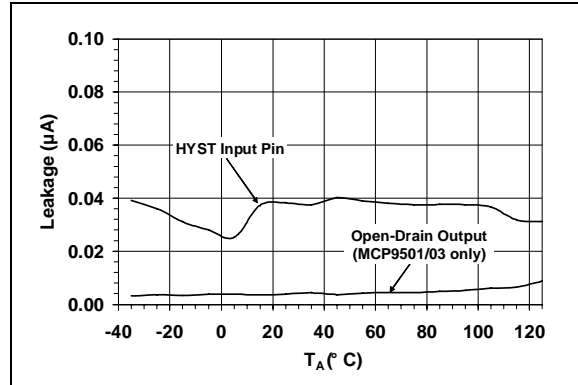

FIGURE 2-4: Leakage vs. Temperature.

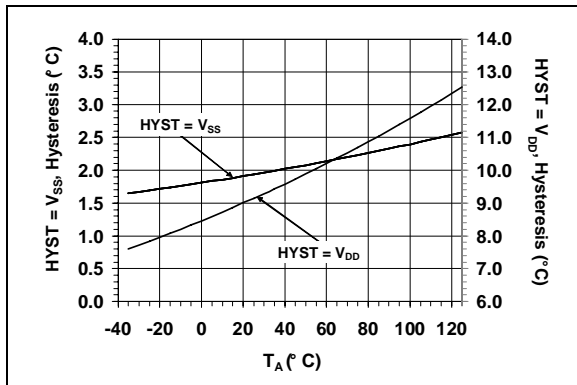

FIGURE 2-2: Hysteresis vs. Temperature.

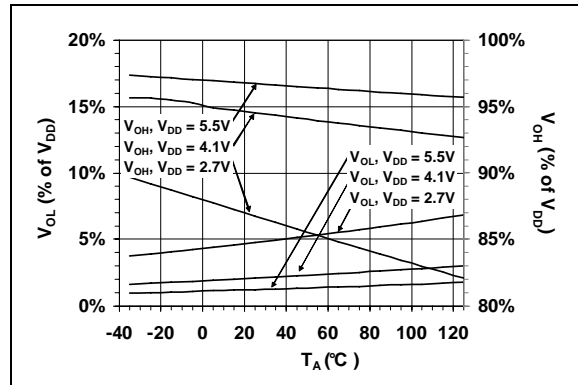

FIGURE 2-5:  $V_{OL}, V_{OH}$  vs. Temperature.

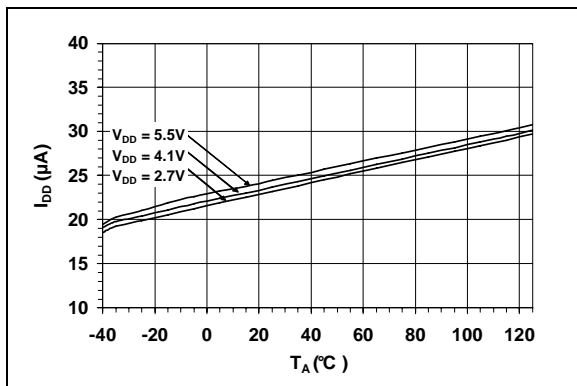

FIGURE 2-3: Supply Current vs. Temperature.

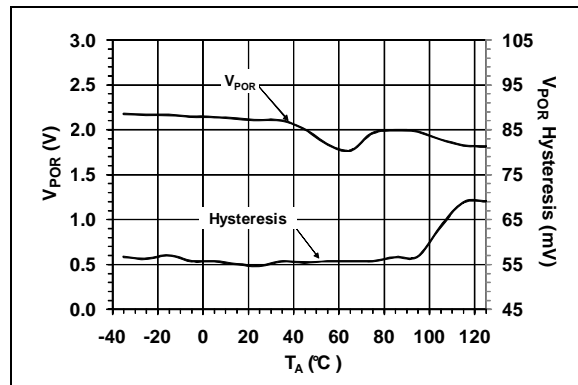
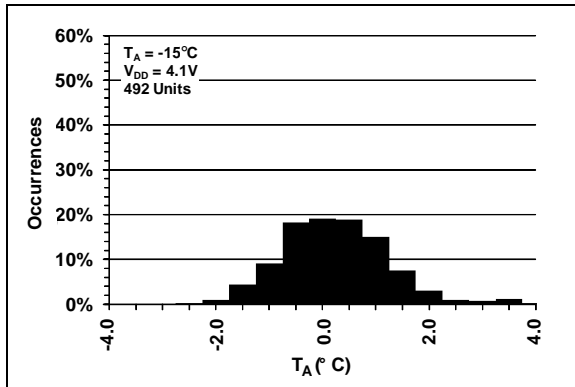
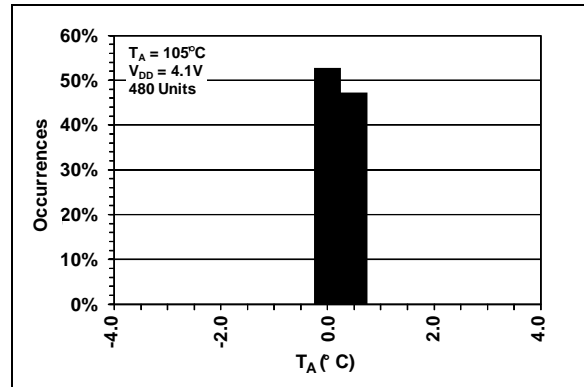

FIGURE 2-6: Power On Reset Threshold vs. Temperature.

**Note:** Unless otherwise indicated,  $V_{DD} = 2.7V$  to  $5.5V$ ,  $T_A = -40^{\circ}C$  to  $+125^{\circ}C$ ,  $GND = \text{Ground}$ ,  $R_{PULL-UP} = 10\text{ k}\Omega$  (MCP9501 only) and  $0.1\text{ }\mu\text{F}$  bypass capacitor.



**FIGURE 2-7:** Temperature Accuracy Distribution at  $-15^{\circ}C$ .



**FIGURE 2-10:** Temperature Accuracy Distribution at  $105^{\circ}C$ .

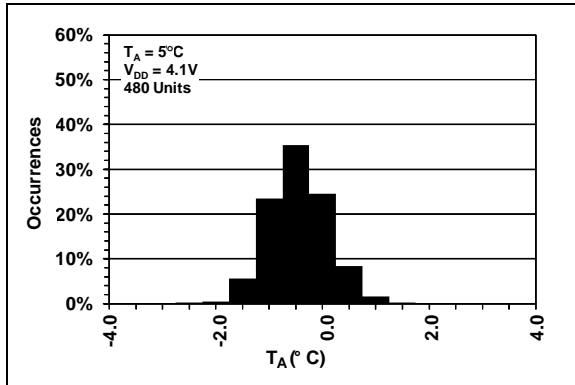

**FIGURE 2-8:** Temperature Accuracy Distribution at  $5^{\circ}C$ .

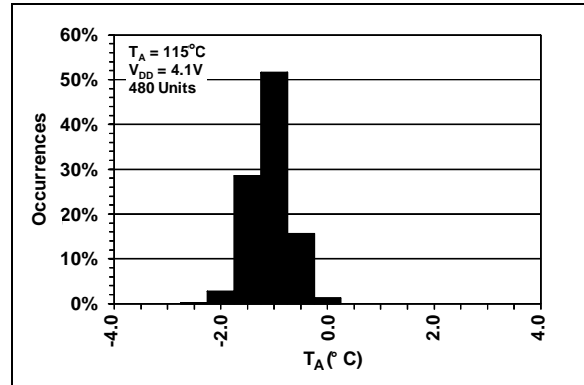

**FIGURE 2-11:** Temperature Accuracy Distribution at  $115^{\circ}C$ .

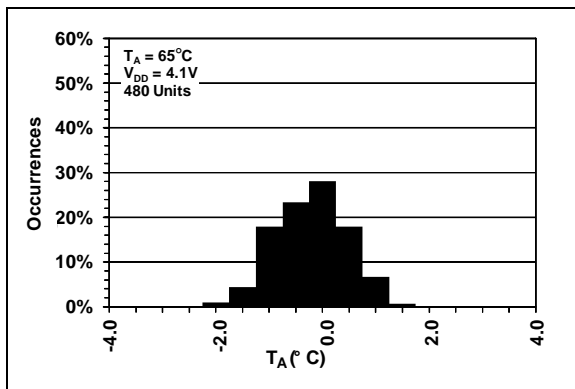

**FIGURE 2-9:** Temperature Accuracy Distribution at  $65^{\circ}C$ .

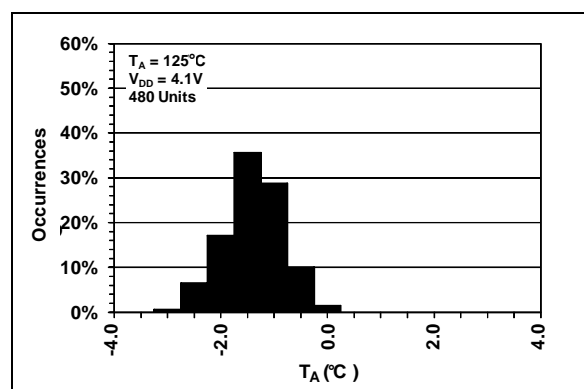

**FIGURE 2-12:** Temperature Accuracy Distribution at  $125^{\circ}C$ .

# MCP9501/2/3/4

## 3.0 PIN DESCRIPTIONS

TABLE 3-1: PIN FUNCTION TABLE

MCP9501/2/3/4	Symbol	Description
SOT-23-5		
1	GND	Ground
2	GND	Ground (must be connected to ground)
3	HYST	Hysteresis Selection Input: HYST = GND → Hysteresis is 2°C (typical) HYST = V <sub>DD</sub> → Hysteresis is 10°C (typical)
4	V <sub>DD</sub>	Power pin
5	Output	Output Options: MCP9501 → Open-Drain, Active-Low Output (Hot-Option) MCP9502 → Push-Pull, Active-High Output (Hot-Option) MCP9503 → Open-Drain, Active-Low Output (Cold-Option) MCP9504 → Push-Pull, Active-High Output (Cold-Option)

### 3.1 Ground (GND)

The GND pin is the system ground pin. Pin 2 must be connected to system ground. Pin 1 can also be connected to system ground which would provide better thermal conduction to the die.

### 3.2 Hysteresis Input (HYS)

This is an input pin which can be connected to V<sub>DD</sub> or GND to select output hysteresis. Either 2°C (HYST = GND) or 10°C (HYST = V<sub>DD</sub>) of typical hysteresis can be selected.

### 3.3 Power Pin (V<sub>DD</sub>)

The operating voltage range, as specified in the DC electrical specification table, is applied on this pin.

### 3.4 Switch Output (Output)

This output is triggered when temperature rises or falls beyond the programmed trip temperature threshold. MCP9501/3 require an external pull-up resistor.

NOTES:

# MCP9501/2/3/4

## 4.0 FUNCTIONAL DESCRIPTION

The MCP9501/2/3/4 temperature switch family integrates a thermal diode, a comparator, and a factory selectable resistive network used to set the temperature thresholds. The available output thresholds range from  $-35^{\circ}\text{C}$  to  $125^{\circ}\text{C}$  at  $10^{\circ}\text{C}$  increments. There is no additional configuration required to operate this device. The selectable output hysteresis is controlled using a single input pin. When this pin is connected to ground, the output hysteresis is  $2^{\circ}\text{C}$  (typical) and when connected to  $V_{\text{DD}}$  the output hysteresis is  $10^{\circ}\text{C}$  (typical). Figure 4-1 shows the functional block diagram.

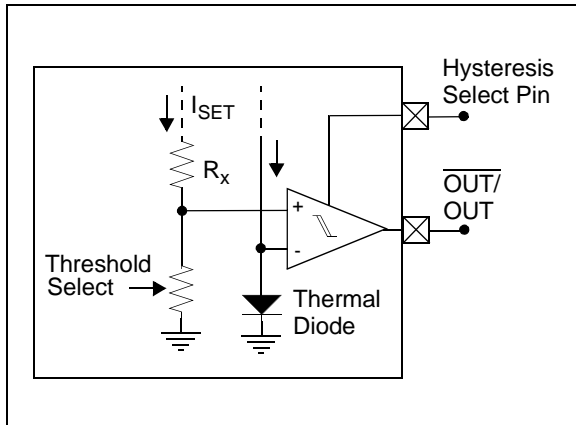

FIGURE 4-1: Functional Block Diagram.

There are two output configurations for this family, a push-pull and an open-drain output with active-high and active-low assertions. These assertion options are referred to as Cold and Hot options, primarily due to the direction of selected hysteresis. For the Cold option, temperature has to fall below the threshold for the output to assert High, and de-assert Low when the temperature rises above the threshold plus the hysteresis. For example, a  $65^{\circ}\text{C}$  threshold and  $2^{\circ}\text{C}$  (typical) hysteresis, when temperature falls below  $65^{\circ}\text{C}$  the output asserts High, and the de-asserts Low when temperature rises above  $67^{\circ}\text{C}$ . For the Hot option, the opposite is true. When temperature rises above  $65^{\circ}\text{C}$ , the output asserts Low, and de-asserts High when the temperature falls below  $63^{\circ}\text{C}$ . Figure 4-2 shows a graphical description for the Hot and Cold options.

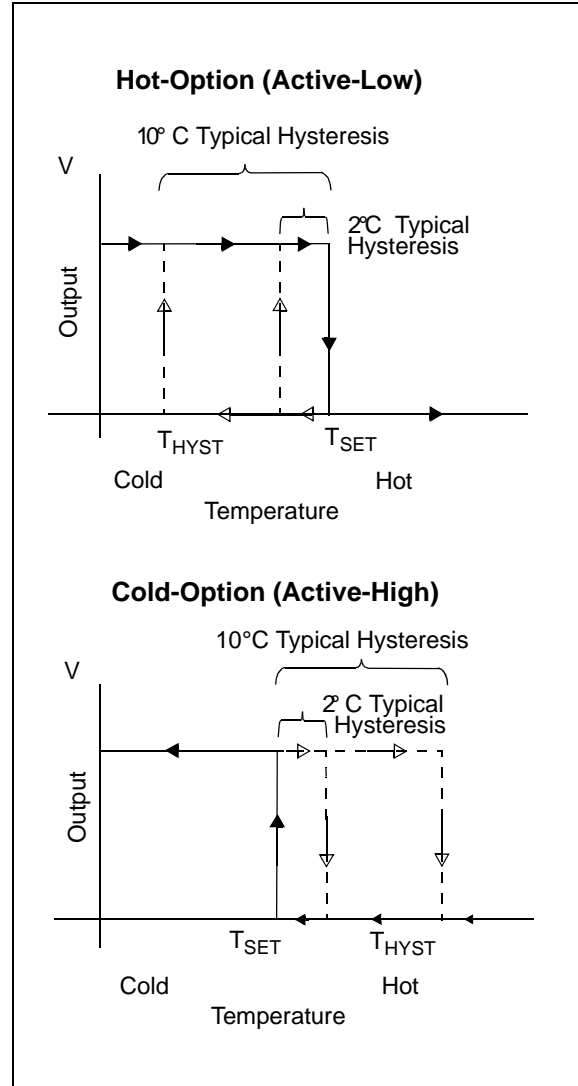

FIGURE 4-2: Output Hysteresis.

The Push-Pull output is ideal for a microcontroller interface using an input/output pin or an interrupt input pin. The open-drain option can be used with multiple sensors in a wired-OR configuration or as a level shifter.



## 4.1 Application Information

The MCP9501/2/3/4 temperature switch family integrates a temperature sensor and a comparator circuit which outputs an alert signal when the factory set temperature threshold is exceeded. No additional component is required for device operation, which provides simplicity to the system designer. The device output options provide design flexibility for various applications such as overtemperature protection circuit or a closed loop temperature control unit. This device can be interfaced to a closed loop fan controller network without the need for a microcontroller.

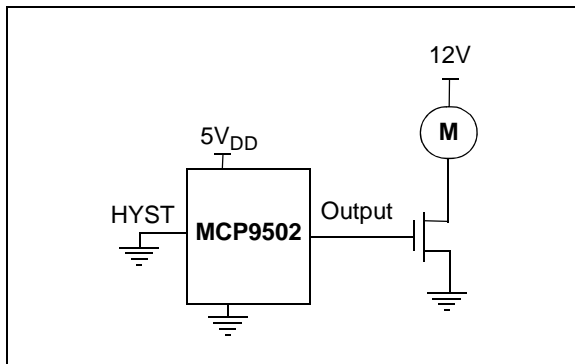

**FIGURE 4-3:** Fan Controller Using MCP9502.

The MCP9501/2/3/4 provide Open-Drain output where multiple sensors from multiple PCB hot-spots can be connected to a single processor I/O input with a wired-OR configuration. The MCP9501 requires an external pull-up resistor which can be used to level-shift the alert signal. For example, if the sensors are powered with  $5V_{DD}$  and the controller or processor is powered with  $3V_{DD}$ , the external resistor can be level-shifted by connecting  $3V_{DD}$  to the pull-up resistor as shown in Figure 4-4.

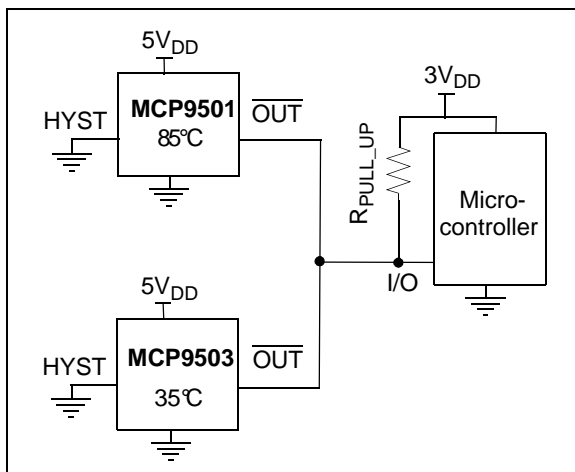

**FIGURE 4-4:** MCP9501 Wired-OR Output Configuration with Level-shift.

### 4.1.1 LAYOUT CONSIDERATION AND THERMAL CONSIDERATION

This family of sensors measures temperature by monitoring the voltage level of a thermal diode located in the die. A low-impedance thermal path between the die and the PCB is provided by the pins. Therefore, the sensor effectively monitors PCB temperature. For efficient performance, it is recommended to layout the device as close to the heat source as possible.

When connecting an external resistor to the MCP9501/3, the current through the pull-up resistor must be considered to prevent self-heat due to power. This can be determined using Equation 4-1.

#### EQUATION 4-1: EFFECT OF SELF-HEATING

$$T_J - T_A = \theta_{JA}(V_{DD} \times I_{DD} + V_{OL} \times I_{OUT})$$

Where:

$T_J$	=	Junction Temperature
$T_A$	=	Ambient Temperature
$\theta_{JA}$	=	Package Thermal Resistance (220.7 °C/W)
$V_{OL}$	=	Sensor Output Low Voltage
$I_{OUT}$	=	Output Current

For example, at room temperature, when the output asserts Active-Low and maximum  $I_{DD} = 50 \mu A$ ,  $V_{DD} = 5.5V$ ,  $V_{OL} = 0.3V$  and  $I_{OUT} = 5 \text{ mA}$  (see the specification table), the self heating due to power dissipation ( $T_J - T_A$ ) is  $\sim 0.4^\circ C$ .

# MCP9501/2/3/4

## 4.1.2 POWER SUPPLY REJECTION

The MCP9501/2/3/4 family does not require any additional components. However, it is recommended that a decoupling capacitor of 0.1  $\mu\text{F}$  to 1  $\mu\text{F}$  be used between the  $V_{\text{DD}}$  and GND pins. A high-frequency ceramic capacitor is recommended. It is necessary for the capacitor to be located as close as possible to the power pins in order to provide effective noise protection.

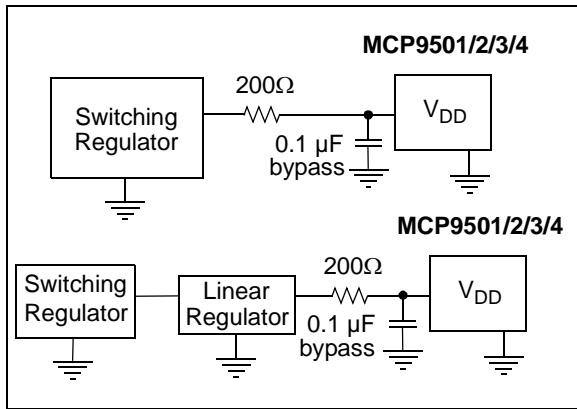

**FIGURE 4-5:** Power-supply Filter using a Single Resistor.

For applications where a switching regulator is used to power the sensor, it is recommended to add a 200 $\Omega$  resistor in series to  $V_{\text{DD}}$  to filter out the switcher noise. It is also recommended to add the series resistor in applications where a linear regulator is used to step-down a switching regulator voltage to power the sensor, as shown in Figure 4-5. For example, if a linearly regulated 3.3V from a 5V switching regulator is used to power the sensor, add a 200 $\Omega$  series resistor.

The MCP9501/2/3/4 family of sensors is designed to prevent false output trigger due to high frequency power supply or system noise. Figure 4-6 shows the device performance with a high frequency signal added on  $V_{\text{DD}}$ . The output is not triggered due to the signal added on  $V_{\text{DD}}$ . With some applications, it is recommended to add a bypass capacitor of 0.1  $\mu\text{F}$  to 1  $\mu\text{F}$ .

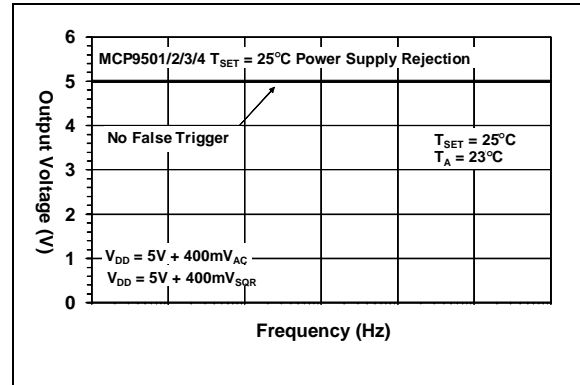

**FIGURE 4-6:** Power Supply Rejection.

NOTES:

# MCP9501/2/3/4

## 5.0 PACKAGING INFORMATION

### 5.1 Package Marking Information

5-Lead SOT-23

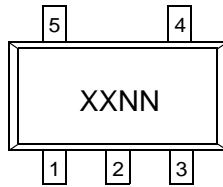

Example:

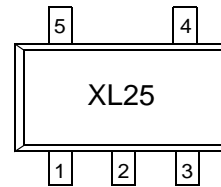

Device	Code	Device	Code
<b>Hot Options</b>			
MCP9501PT-005E/OT	WVNN	MCP9502PT-005E/OT	XLNN
MCP9501PT-015E/OT	WWNN	MCP9502PT-015E/OT	XMNN
MCP9501PT-025E/OT	WXNN	MCP9502PT-025E/OT	XPNN
MCP9501PT-035E/OT	WYNN	MCP9502PT-035E/OT	XQNN
MCP9501PT-045E/OT	WZNN	MCP9502PT-045E/OT	XRNN
MCP9501PT-055E/OT	X1NN	MCP9502PT-055E/OT	XSNN
MCP9501PT-065E/OT	X2NN	MCP9502PT-065E/OT	XTNN
MCP9501PT-075E/OT	X3NN	MCP9502PT-075E/OT	XUNN
MCP9501PT-085E/OT	X4NN	MCP9502PT-085E/OT	XVNN
MCP9501PT-095E/OT	X5NN	MCP9502PT-095E/OT	XWNN
MCP9501PT-105E/OT	X6NN	MCP9502PT-105E/OT	XXNN
MCP9501PT-115E/OT	X7NN	MCP9502PT-115E/OT	XYNN
MCP9501PT-125E/OT	X8NN	MCP9502PT-125E/OT	XZNN
MCP9503PT-005E/OT	XHNN	MCP9501PT-005E/OT	Y9NN
MCP9503PT-015E/OT	XJNN	MCP9501PT-015E/OT	YANN
MCP9503PT-125E/OT	XKNN	MCP9501PT-025E/OT	YBNN
<b>Cold Options</b>			
MCP9503NT-005E/OT	XBNN	MCP9501NT-005E/OT	Y3NN
MCP9503NT-015E/OT	XCNN	MCP9501NT-015E/OT	Y4NN
MCP9503NT-025E/OT	XDNN	MCP9501NT-025E/OT	Y5NN
MCP9503NT-035E/OT	XENN	MCP9501NT-035E/OT	Y6NN

**Note:** Contact Microchip for all other threshold options.

<b>Legend:</b>	XX...X	Customer-specific information
	Y	Year code (last digit of calendar year)
	YY	Year code (last 2 digits of calendar year)
	WW	Week code (week of January 1 is week '01')
	NNN	Alphanumeric traceability code
	(e3)	Pb-free JEDEC designator for Matte Tin (Sn)
	*	This package is Pb-free. The Pb-free JEDEC designator (e3) can be found on the outer packaging for this package.
<b>Note:</b>	In the event the full Microchip part number cannot be marked on one line, it will be carried over to the next line, thus limiting the number of available characters for customer-specific information.	

## 5-Lead Plastic Small Outline Transistor (OT) [SOT-23]

**Note:** For the most current package drawings, please see the Microchip Packaging Specification located at <http://www.microchip.com/packaging>

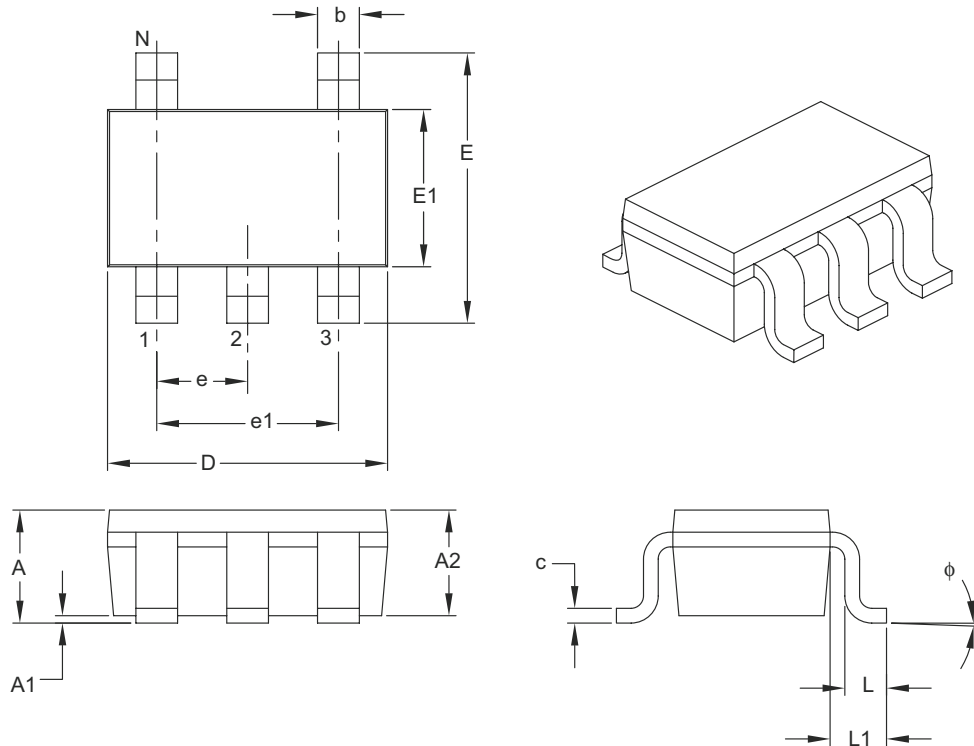

Dimension Limits	Units	MILLIMETERS		
		MIN	NOM	MAX
Number of Pins	N	5		
Lead Pitch	e	0.95 BSC		
Outside Lead Pitch	e1	1.90 BSC		
Overall Height	A	0.90	–	1.45
Molded Package Thickness	A2	0.89	–	1.30
Standoff	A1	0.00	–	0.15
Overall Width	E	2.20	–	3.20
Molded Package Width	E1	1.30	–	1.80
Overall Length	D	2.70	–	3.10
Foot Length	L	0.10	–	0.60
Footprint	L1	0.35	–	0.80
Foot Angle	$\phi$	0°	–	30°
Lead Thickness	c	0.08	–	0.26
Lead Width	b	0.20	–	0.51

**Notes:**

- Dimensions D and E1 do not include mold flash or protrusions. Mold flash or protrusions shall not exceed 0.127 mm per side.
- Dimensioning and tolerancing per ASME Y14.5M.

BSC: Basic Dimension. Theoretically exact value shown without tolerances.

Microchip Technology Drawing C04-091B

# MCP9501/2/3/4

## 5-Lead Plastic Small Outline Transistor (OT) [SOT-23]

**Note:** For the most current package drawings, please see the Microchip Packaging Specification located at <http://www.microchip.com/packaging>

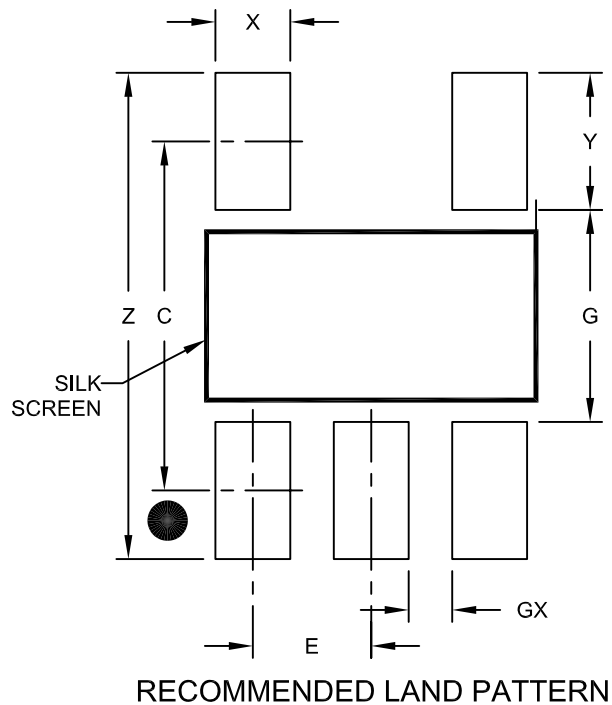

Dimension Limits	Units	MILLIMETERS		
		MIN	NOM	MAX
Contact Pitch	E	0.95 BSC		
Contact Pad Spacing	C		2.80	
Contact Pad Width (X5)	X			0.60
Contact Pad Length (X5)	Y			1.10
Distance Between Pads	G	1.70		
Distance Between Pads	GX	0.35		
Overall Width	Z			3.90

**Notes:**

1. Dimensioning and tolerancing per ASME Y14.5M

BSC: Basic Dimension, Theoretically exact value shown without tolerances.

Microchip Technology Drawing No. C04-2091A

## APPENDIX A: REVISION HISTORY

### Revision A (January 2011)

- Original Release of this Document.

# MCP9501/2/3/4

---

NOTES:



## PRODUCT IDENTIFICATION SYSTEM

To order or obtain information, e.g., on pricing or delivery, refer to the factory or the listed sales office.

<u>PART NO.</u>	<u>-XXXX</u>	<u>X</u>	<u>XX</u>	<b>Examples:</b>
<b>Device</b>	<b>Temperature Switch Threshold</b>	<b>Temperature Range</b>	<b>Package</b>	
Device:	MCP9501P: Resistor Programmable Temperature Switch, Hot Option			a) MCP9501PT-025E/OT: Active-Low, Open-Drain Output, 25° C Switch Threshold, Hot Option, Extended Temp., 5LD SOT-23 pkg.
	MCP9502P: Resistor Programmable Temperature Switch, Hot Option			b) MCP9502PT-025E/OT: Active-High, Push-Pull Output, 25° C Switch Threshold, Hot Option, Extended Temp., 5LD SOT-23 pkg.
	MCP9503N: Resistor Programmable Temperature Switch, Cold Option			c) MCP9503NT-025E/OT: Active-Low, Open-Drain Output, -25° C Switch Threshold, Cold Option, Extended Temp., 5LD SOT-23 pkg.
	MCP9504N: Resistor Programmable Temperature Switch, Cold Option			d) MCP9504NT-025E/OT: Active-High, Push-Pull Output, -25°C Switch Threshold, Cold Option, Extended Temp., 5LD SOT-23 pkg.
Temperature Switch Threshold:	005, 015, 025, 035, 045, 055, 065, 075, 085, 095, 105, 115, 125			e) MCP9501PT-105E/OT: Active-Low, Open-Drain Output, 105°C Switch Threshold, Hot Option, Extended Temp., 5LD SOT-23 pkg.
Temperature Range:	E = -40°C to +125°C			f) MCP9502PT-105E/OT: Active-High, Push-Pull Output, 105°C Switch Threshold, Hot Option, Extended Temp., 5LD SOT-23 pkg.
Package:	OT = Plastic Small Outline Transistor (SOT-23), 5-lead			g) MCP9503NT-035E/OT: Active-Low, Open-Drain Output, -35°C Switch Threshold, Cold Option, Extended Temp., 5LD SOT-23 pkg.
				h) MCP9504NT-035E/OT: Active-High, Push-Pull Output, -35° C Switch Threshold, Cold Option, Extended Temp., 5LD SOT-23 pkg.

# MCP9501/2/3/4

---

NOTES:

---

**Note the following details of the code protection feature on Microchip devices:**

- Microchip products meet the specification contained in their particular Microchip Data Sheet.
- Microchip believes that its family of products is one of the most secure families of its kind on the market today, when used in the intended manner and under normal conditions.
- There are dishonest and possibly illegal methods used to breach the code protection feature. All of these methods, to our knowledge, require using the Microchip products in a manner outside the operating specifications contained in Microchip's Data Sheets. Most likely, the person doing so is engaged in theft of intellectual property.
- Microchip is willing to work with the customer who is concerned about the integrity of their code.
- Neither Microchip nor any other semiconductor manufacturer can guarantee the security of their code. Code protection does not mean that we are guaranteeing the product as "unbreakable."

Code protection is constantly evolving. We at Microchip are committed to continuously improving the code protection features of our products. Attempts to break Microchip's code protection feature may be a violation of the Digital Millennium Copyright Act. If such acts allow unauthorized access to your software or other copyrighted work, you may have a right to sue for relief under that Act.

---

Information contained in this publication regarding device applications and the like is provided only for your convenience and may be superseded by updates. It is your responsibility to ensure that your application meets with your specifications. MICROCHIP MAKES NO REPRESENTATIONS OR WARRANTIES OF ANY KIND WHETHER EXPRESS OR IMPLIED, WRITTEN OR ORAL, STATUTORY OR OTHERWISE, RELATED TO THE INFORMATION, INCLUDING BUT NOT LIMITED TO ITS CONDITION, QUALITY, PERFORMANCE, MERCHANTABILITY OR FITNESS FOR PURPOSE. Microchip disclaims all liability arising from this information and its use. Use of Microchip devices in life support and/or safety applications is entirely at the buyer's risk, and the buyer agrees to defend, indemnify and hold harmless Microchip from any and all damages, claims, suits, or expenses resulting from such use. No licenses are conveyed, implicitly or otherwise, under any Microchip intellectual property rights.

**Trademarks**

The Microchip name and logo, the Microchip logo, dsPIC, KEELOQ, KEELOQ logo, MPLAB, PIC, PICmicro, PICSTART, PIC<sup>32</sup> logo, rPIC and UNI/O are registered trademarks of Microchip Technology Incorporated in the U.S.A. and other countries.

FilterLab, Hampshire, HI-TECH C, Linear Active Thermistor, MXDEV, MXLAB, SEEVAL and The Embedded Control Solutions Company are registered trademarks of Microchip Technology Incorporated in the U.S.A.

Analog-for-the-Digital Age, Application Maestro, CodeGuard, dsPICDEM, dsPICDEM.net, dsPICworks, dsSPEAK, ECAN, ECONOMONITOR, FanSense, HI-TIDE, In-Circuit Serial Programming, ICSP, Mindi, MiWi, MPASM, MPLAB Certified logo, MPLIB, MPLINK, mTouch, Octopus, Omniscient Code Generation, PICC, PICC-18, PICDEM, PICDEM.net, PICkit, PICTail, REAL ICE, rLAB, Select Mode, Total Endurance, TSHARC, UniWinDriver, WiperLock and ZENA are trademarks of Microchip Technology Incorporated in the U.S.A. and other countries.

SQTP is a service mark of Microchip Technology Incorporated in the U.S.A.

All other trademarks mentioned herein are property of their respective companies.

© 2011, Microchip Technology Incorporated, Printed in the U.S.A., All Rights Reserved.

 Printed on recycled paper.

ISBN: 978-1-60932-861-0

*Microchip received ISO/TS-16949:2002 certification for its worldwide headquarters, design and wafer fabrication facilities in Chandler and Tempe, Arizona; Gresham, Oregon and design centers in California and India. The Company's quality system processes and procedures are for its PIC® MCUs and dsPIC® DSCs, KEELOQ® code hopping devices, Serial EEPROMs, microperipherals, nonvolatile memory and analog products. In addition, Microchip's quality system for the design and manufacture of development systems is ISO 9001:2000 certified.*

**QUALITY MANAGEMENT SYSTEM  
CERTIFIED BY DNV  
== ISO/TS 16949:2002 ==**



# MICROCHIP

## Worldwide Sales and Service

### AMERICAS

**Corporate Office**  
2355 West Chandler Blvd.  
Chandler, AZ 85224-6199  
Tel: 480-792-7200  
Fax: 480-792-7277  
Technical Support:  
<http://support.microchip.com>  
Web Address:  
[www.microchip.com](http://www.microchip.com)

**Atlanta**  
Duluth, GA  
Tel: 678-957-9614  
Fax: 678-957-1455

**Boston**  
Westborough, MA  
Tel: 774-760-0087  
Fax: 774-760-0088

**Chicago**  
Itasca, IL  
Tel: 630-285-0071  
Fax: 630-285-0075

**Cleveland**  
Independence, OH  
Tel: 216-447-0464  
Fax: 216-447-0643

**Dallas**  
Addison, TX  
Tel: 972-818-7423  
Fax: 972-818-2924

**Detroit**  
Farmington Hills, MI  
Tel: 248-538-2250  
Fax: 248-538-2260

**Kokomo**  
Kokomo, IN  
Tel: 765-864-8360  
Fax: 765-864-8387

**Los Angeles**  
Mission Viejo, CA  
Tel: 949-462-9523  
Fax: 949-462-9608

**Santa Clara**  
Santa Clara, CA  
Tel: 408-961-6444  
Fax: 408-961-6445

**Toronto**  
Mississauga, Ontario,  
Canada  
Tel: 905-673-0699  
Fax: 905-673-6509

### ASIA/PACIFIC

**Asia Pacific Office**  
Suites 3707-14, 37th Floor  
Tower 6, The Gateway  
Harbour City, Kowloon  
Hong Kong  
Tel: 852-2401-1200  
Fax: 852-2401-3431

**Australia - Sydney**  
Tel: 61-2-9868-6733  
Fax: 61-2-9868-6755

**China - Beijing**  
Tel: 86-10-8528-2100  
Fax: 86-10-8528-2104

**China - Chengdu**  
Tel: 86-28-8665-5511  
Fax: 86-28-8665-7889

**China - Chongqing**  
Tel: 86-23-8980-9588  
Fax: 86-23-8980-9500

**China - Hong Kong SAR**  
Tel: 852-2401-1200  
Fax: 852-2401-3431

**China - Nanjing**  
Tel: 86-25-8473-2460  
Fax: 86-25-8473-2470

**China - Qingdao**  
Tel: 86-532-8502-7355  
Fax: 86-532-8502-7205

**China - Shanghai**  
Tel: 86-21-5407-5533  
Fax: 86-21-5407-5066

**China - Shenyang**  
Tel: 86-24-2334-2829  
Fax: 86-24-2334-2393

**China - Shenzhen**  
Tel: 86-755-8203-2660  
Fax: 86-755-8203-1760

**China - Wuhan**  
Tel: 86-27-5980-5300  
Fax: 86-27-5980-5118

**China - Xian**  
Tel: 86-29-8833-7252  
Fax: 86-29-8833-7256

**China - Xiamen**  
Tel: 86-592-2388138  
Fax: 86-592-2388130

**China - Zhuhai**  
Tel: 86-756-3210040  
Fax: 86-756-3210049

### ASIA/PACIFIC

**India - Bangalore**  
Tel: 91-80-3090-4444  
Fax: 91-80-3090-4123

**India - New Delhi**  
Tel: 91-11-4160-8631  
Fax: 91-11-4160-8632

**India - Pune**  
Tel: 91-20-2566-1512  
Fax: 91-20-2566-1513

**Japan - Yokohama**  
Tel: 81-45-471- 6166  
Fax: 81-45-471-6122

**Korea - Daegu**  
Tel: 82-53-744-4301  
Fax: 82-53-744-4302

**Korea - Seoul**  
Tel: 82-2-554-7200  
Fax: 82-2-558-5932 or  
82-2-558-5934

**Malaysia - Kuala Lumpur**  
Tel: 60-3-6201-9857  
Fax: 60-3-6201-9859

**Malaysia - Penang**  
Tel: 60-4-227-8870  
Fax: 60-4-227-4068

**Philippines - Manila**  
Tel: 63-2-634-9065  
Fax: 63-2-634-9069

**Singapore**  
Tel: 65-6334-8870  
Fax: 65-6334-8850

**Taiwan - Hsin Chu**  
Tel: 886-3-6578-300  
Fax: 886-3-6578-370

**Taiwan - Kaohsiung**  
Tel: 886-7-213-7830  
Fax: 886-7-330-9305

**Taiwan - Taipei**  
Tel: 886-2-2500-6610  
Fax: 886-2-2508-0102

**Thailand - Bangkok**  
Tel: 66-2-694-1351  
Fax: 66-2-694-1350

### EUROPE

**Austria - Wels**  
Tel: 43-7242-2244-39  
Fax: 43-7242-2244-393

**Denmark - Copenhagen**  
Tel: 45-4450-2828  
Fax: 45-4485-2829

**France - Paris**  
Tel: 33-1-69-53-63-20  
Fax: 33-1-69-30-90-79

**Germany - Munich**  
Tel: 49-89-627-144-0  
Fax: 49-89-627-144-44

**Italy - Milan**  
Tel: 39-0331-742611  
Fax: 39-0331-466781

**Netherlands - Drunen**  
Tel: 31-416-690399  
Fax: 31-416-690340

**Spain - Madrid**  
Tel: 34-91-708-08-90  
Fax: 34-91-708-08-91

**UK - Wokingham**  
Tel: 44-118-921-5869  
Fax: 44-118-921-5820

08/04/10