

I²C™ Real-Time Clock/Calendar with SRAM, Unique ID and Battery Switchover

Device Selection Table

Part Number	SRAM (Bytes)	Unique ID
MCP79400	64	Blank
MCP79401	64	EUI-48™
MCP79402	64	EUI-64™

Features:

- Real-Time Clock/Calendar (RTCC), Battery Backed:
 - Hours, Minutes, Seconds, Day of Week, Day, Month and Year
 - Dual alarm with single output
- On-Chip Digital Trimming/Calibration:
 - Range -127 to +127 ppm
 - Resolution 1 ppm
- Programmable Open-Drain Output Control:
 - CLKOUT with 4 selectable frequencies
 - Alarm output
- 64 Bytes SRAM, Battery Backed
- 64-Bit Unique ID:
 - User or factory programmable
 - Protected EEPROM
 - EUI-48™ or EUI-64™ MAC address
 - Custom ID programming
- Automatic VCC Switchover to VBAT Backup Supply
- Power-Fail Time-Stamp for Battery Switchover
- Low-Power CMOS Technology:
 - Dynamic Current: 400 µA max read
 - Dynamic Current: 400 µA max SRAM
 - Battery Backup Current: <700nA @ 1.8V
- 100 kHz and 400 kHz Compatibility
- ESD Protection >4,000V
- 1 Million Erase/Write Cycles for Unique ID
- Packages include 8-Lead SOIC, TSSOP, 2x3 TDFN, MSOP
- Pb-Free and RoHS Compliant
- Temperature Ranges:
 - Industrial (I): -40°C to +85°C

Description:

The MCP7940X series of low-power Real-Time Clocks (RTC) uses digital timing compensation for an accurate clock/calendar, a programmable output control for versatility, a power sense circuit that automatically switches to the backup supply, and nonvolatile memory for data storage. Using a low-cost 32.768 kHz crystal, it tracks time using several internal registers. For communication, the MCP7940X uses the I²C™ bus.

The clock/calendar automatically adjusts for months with fewer than 31 days, including corrections for leap years. The clock operates in either the 24-hour or 12-hour format with an AM/PM indicator and settable alarm(s) to the second, minute, hour, day of the week, date or month. Using the programmable CLKOUT, frequencies of 32.768, 8.192 and 4.096 kHz and 1 Hz can be generated from the external crystal.

Along with the battery-backed SRAM memory, a 64-bit protected EEPROM space is available for a unique ID or MAC address to be programmed at the factory or by the end user.

The device is fully accessible through the serial interface while VCC is between 1.8V and 5.5V, but can operate down to 1.3V for timekeeping and SRAM retention only.

The RTC series of devices are available in the standard 8-lead SOIC, TSSOP, MSOP and 2x3 TDFN packages.

Package Types

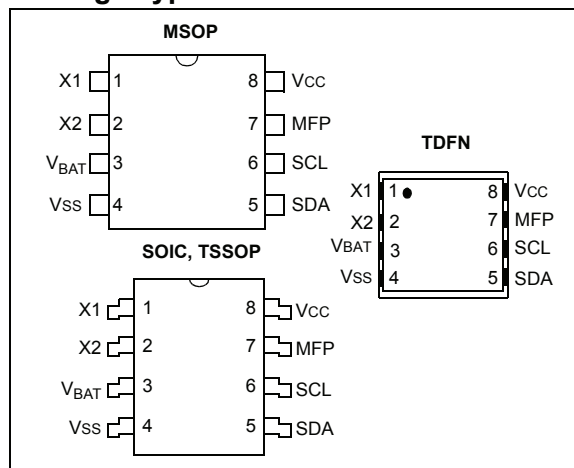

MCP7940X

FIGURE 1-1: TYPICAL OPERATING CIRCUIT

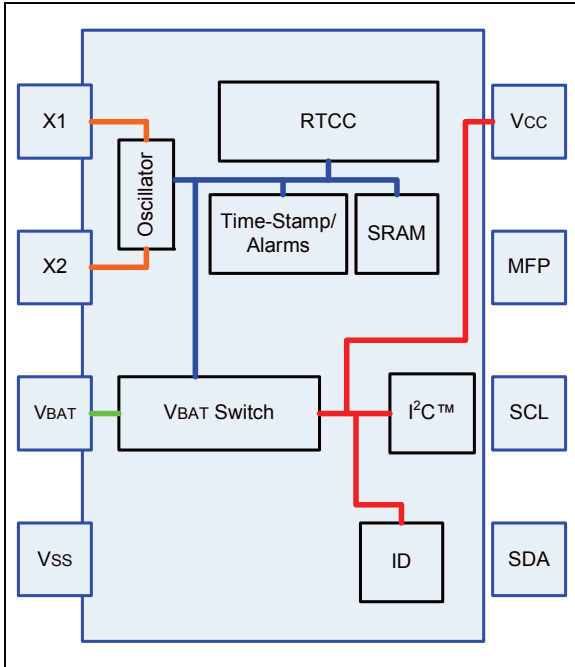
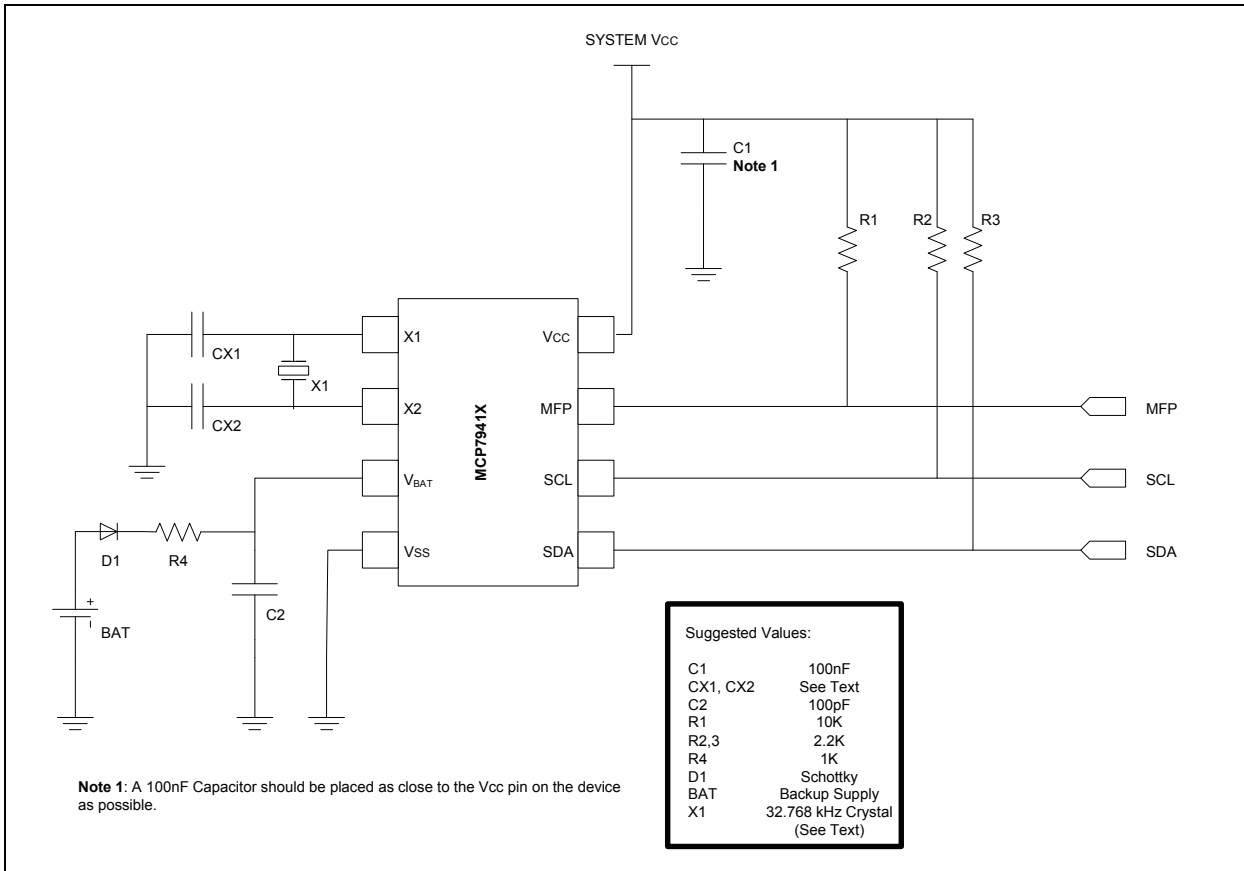

FIGURE 1-2: SCHEMATIC



1.0 ELECTRICAL CHARACTERISTICS

Absolute Maximum Ratings (†)

V _{CC}	6.5V
All inputs and outputs w.r.t. V _{SS}	-0.6V to V _{CC} +1.0V
Storage temperature	-65°C to +150°C
Ambient temperature with power applied.....	-40°C to +125°C
ESD protection on all pins	≥ 4 kV

† NOTICE: Stresses above those listed under “Absolute Maximum Ratings” may cause permanent damage to the device. This is a stress rating only and functional operation of the device at those or any other conditions above those indicated in the operational listings of this specification is not implied. Exposure to maximum rating conditions for extended periods may affect device reliability.

TABLE 1-1: DC CHARACTERISTICS

DC CHARACTERISTICS			Electrical Characteristics: Industrial (I): V _{CC} = +1.8V to 5.5V T _A = -40°C to +85°C				
Param. No.	Sym.	Characteristic	Min.	Typ.	Max.	Units	Conditions
	—	SCL, SDA pins	—		—	—	—
D1	V _{IH}	High-level input voltage	0.7 V _{CC}		—	V	—
D2	V _{IL}	Low-level input voltage	—		0.3 V _{CC} 0.2 V _{CC}	V	V _{CC} = 2.5V to 5.5V
D3	V _{HYS}	Hysteresis of Schmitt Trigger inputs (SDA, SCL pins)	0.05 V _{CC}		—	V	(Note 1)
D4	V _{OL}	Low-level output voltage (MFP, SDA)	—		0.40	V	I _{OL} = 3.0 ma @ V _{CC} = 4.5V I _{OL} = 2.1 ma @ V _{CC} = 2.5V
D5	I _{LI}	Input leakage current	—		±1	μA	V _{IN} = V _{SS} or V _{CC}
D6	I _{LO}	Output leakage current	—		±1	μA	V _{OUT} = V _{SS} or V _{CC}
D7	C _{IN} , C _{OUT}	Pin capacitance (SDA, SCL and MFP)	—		10	pF	V _{CC} = 5.0V (Note 1) T _A = 25°C, f = 400 kHz
D8	I _{CC} Read	Operating current	—		400	μA	V _{CC} = 5.5V, SCL = 400 kHz
	I _{CC} Write	ID	—		3	mA	V _{CC} = 5.5V
D9	I _{CC} Read	Operating current	—		300	μA	V _{CC} = 5.5V, SCL = 400 kHz
	I _{CC} Write	SRAM	—		400	μA	V _{CC} = 5.5V, SCL = 400 kHz
D10	I _{CCS}	Standby current (Note 2)	—		5	μA	V _{CC} = 5.5V, SCL = SDA = V _{CC}
D11	I _{BAT}	V _{BAT} Standby Current (Note 2)	—	700	—	nA	V _{BAT} = 1.8V @ 25°C
D12	V _{TRIP}	V _{BAT} Change Over	1.3		1.7	V	1.5V typical at T _{AMB} = 25°C
D13	V _{CCFT}	V _{CC} Fall Time (Note 1)	300		—	μs	From V _{TRIP} (max) to V _{TRIP} (min)
D14	V _{CCRT}	V _{CC} Rise Time (Note 1)	0		—	μs	From V _{TRIP} (min) to V _{TRIP} (max)
D15	V _{BAT}	V _{BAT} Voltage Range (Note 1)	1.3		5.5	V	—
D16	C _{OSC}	Oscillator Pin Capacitance	—	3	—	pF	(Note 1)

Note 1: This parameter is periodically sampled and not 100% tested.

2: Standby with oscillator running.

MCP7940X

TABLE 1-2: AC CHARACTERISTICS

AC CHARACTERISTICS			Electrical Characteristics: Industrial (I): V _{CC} = +1.8V to 5.5V T _A = -40°C to +85°C			
Param. No.	Symbol	Characteristic	Min.	Max.	Units	Conditions
1	FCLK	Clock frequency	— —	100 400	kHz	1.8V ≤ V _{CC} < 2.5V 2.5V ≤ V _{CC} ≤ 5.5V
2	THIGH	Clock high time	4000 600	— —	ns	1.8V ≤ V _{CC} < 2.5V 2.5V ≤ V _{CC} ≤ 5.5V
3	TLOW	Clock low time	4700 1300	— —	ns	1.8V ≤ V _{CC} < 2.5V 2.5V ≤ V _{CC} ≤ 5.5V
4	TR	SDA and SCL rise time (Note 1)	— —	1000 300	ns	1.8V ≤ V _{CC} < 2.5V 2.5V ≤ V _{CC} ≤ 5.5V
5	TF	SDA and SCL fall time (Note 1)	— —	1000 300	ns	1.8V ≤ V _{CC} < 2.5V 2.5V ≤ V _{CC} ≤ 5.5V
6	THD:STA	Start condition hold time	4000 600	— —	ns	1.8V ≤ V _{CC} < 2.5V 2.5V ≤ V _{CC} ≤ 5.5V
7	TSU:STA	Start condition setup time	4700 600	— —	ns	1.8V ≤ V _{CC} < 2.5V 2.5V ≤ V _{CC} ≤ 5.5V
8	THD:DAT	Data input hold time	0	—	ns	
9	TSU:DAT	Data input setup time	250 100	— —	ns	1.8V ≤ V _{CC} < 2.5V 2.5V ≤ V _{CC} ≤ 5.5V
10	TSU:STO	Stop condition setup time	4000 600	— —	ns	1.8V ≤ V _{CC} < 2.5V 2.5V ≤ V _{CC} ≤ 5.5V
11	TAA	Output valid from clock	— —	3500 900	ns	1.8V ≤ V _{CC} < 2.5V 2.5V ≤ V _{CC} ≤ 5.5V
12	TBUF	Bus free time: Time the bus must be free before a new transmission can start	4700 1300	— —	ns	1.8V ≤ V _{CC} < 2.5V 2.5V ≤ V _{CC} ≤ 5.5V
13	TSP	Input filter spike suppression (SDA and SCL pins)	—	50	ns	(Note 1 and Note 2)
14	TWC	Write cycle time (byte or page)	—	5	ms	—
15	—	Endurance	1M	—	cycles	25°C, V _{CC} = 5.5V Page mode (Note 3)

Note 1: Not 100% tested.

Note 2: The combined TSP and VHYS specifications are due to new Schmitt Trigger inputs, which provide improved noise spike suppression. This eliminates the need for a TI specification for standard operation.

Note 3: This parameter is not tested but ensured by characterization. For endurance estimates in a specific application, please consult the Total Endurance™ Model which can be obtained from Microchip's web site at www.microchip.com.

FIGURE 1-2: BUS TIMING DATA

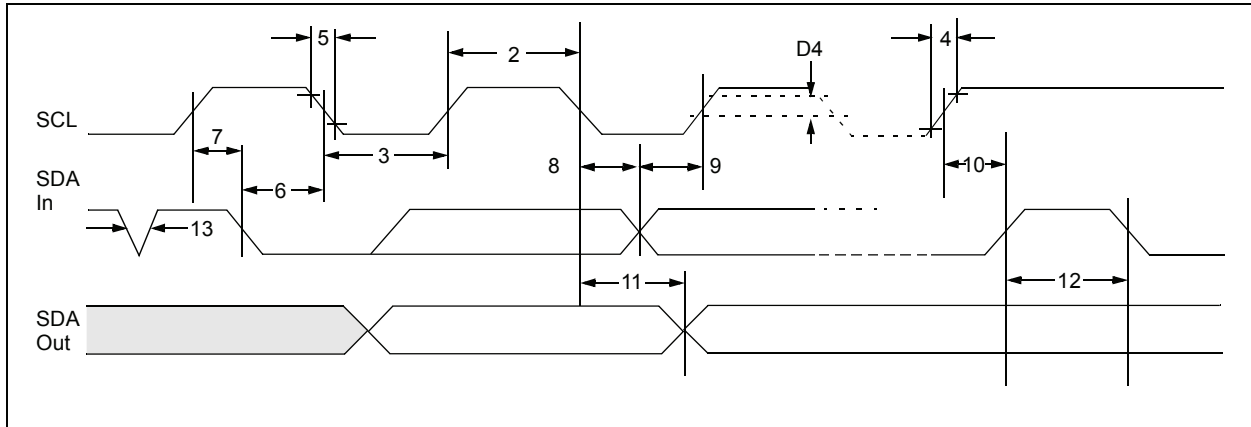

MCP7940X

2.0 PIN DESCRIPTIONS

The descriptions of the pins are listed in [Table 2-1](#).

TABLE 2-1: PIN DESCRIPTIONS

Pin Name	Pin Function
Vss	Ground
SDA	Bidirectional Serial Data
SCL	Serial Clock
X1	Xtal Input, External Oscillator Input
X2	Xtal Output
VBAT	Battery Backup Input (3V Typ)
MFP	Multi Function Pin
Vcc	+1.8V to +5.5V Power Supply

FIGURE 2-1: DEVICE PINOUTS

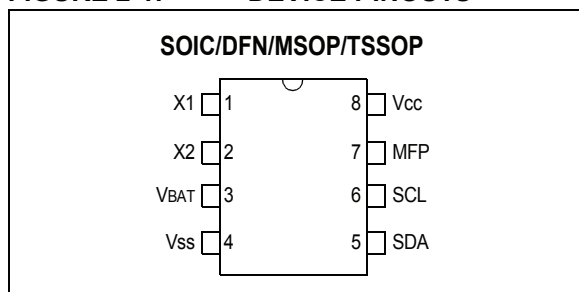

2.1 Serial Data (SDA)

This is a bidirectional pin used to transfer addresses and data into and out of the device. It is an open-drain terminal, therefore, the SDA bus requires a pull-up resistor to Vcc (typically 10 k Ω for 100 kHz, 2 k Ω for 400 kHz). For normal data transfer SDA is allowed to change only during SCL low. Changes during SCL high are reserved for indicating the Start and Stop conditions.

2.2 Serial Clock (SCL)

This input is used to synchronize the data transfer from and to the device.

2.3 X1, X2

External Crystal Pins.

2.4 MFP

Open drain pin used for alarm and clock-out.

2.5 VBAT

Input for backup supply to maintain RTCC and SRAM during the time when Vcc is below VTRIP.

3.0 I²C BUS CHARACTERISTICS

3.1 I²C Interface

The MCP7940X supports a bidirectional 2-wire bus and data transmission protocol. A device that sends data onto the bus is defined as transmitter, and a device receiving data as receiver. The bus has to be controlled by a master device which generates the Start and Stop conditions, while the MCP7940X works as slave. Both master and slave can operate as transmitter or receiver but the master device determines which mode is activated.

3.1.1 BUS CHARACTERISTICS

The following **bus protocol** has been defined:

- Data transfer may be initiated only when the bus is not busy.
- During data transfer, the data line must remain stable whenever the clock line is high. Changes in the data line while the clock line is high will be interpreted as a Start or Stop condition.

Accordingly, the following bus conditions have been defined (Figure 3-1).

3.1.1.1 Bus not Busy (A)

Both data and clock lines remain high.

3.1.1.2 Start Data Transfer (B)

A high-to-low transition of the SDA line while the clock (SCL) is high determines a Start condition. All commands must be preceded by a Start condition.

3.1.1.3 Stop Data Transfer (C)

A low-to-high transition of the SDA line while the clock (SCL) is high determines a Stop condition. All operations must end with a Stop condition.

3.1.1.4 Data Valid (D)

The state of the data line represents valid data when, after a Start condition, the data line is stable for the duration of the high period of the clock signal.

The data on the line must be changed during the low period of the clock signal. There is one bit of data per clock pulse.

Each data transfer is initiated with a Start condition and terminated with a Stop condition. The number of the data bytes transferred between the Start and Stop conditions is determined by the master device.

3.1.1.5 Acknowledge

Each receiving device, when addressed, is obliged to generate an Acknowledge signal after the reception of each byte. The master device must generate an extra clock pulse which is associated with this Acknowledge bit.

Note: The MCP7940X does not generate any Acknowledge bits while an internal Unique ID programming cycle is in progress, but the user may still access the SRAM and RTCC registers.

A device that acknowledges must pull down the SDA line during the Acknowledge clock pulse in such a way that the SDA line is stable-low during the high period of the Acknowledge-related clock pulse. Of course, setup and hold times must be taken into account. During reads, a master must signal an end of data to the slave by NOT generating an Acknowledge bit on the last byte that has been clocked out of the slave. In this case, the slave (MCP7940X) will leave the data line high to enable the master to generate the Stop condition.

FIGURE 3-1: DATA TRANSFER SEQUENCE ON THE SERIAL BUS

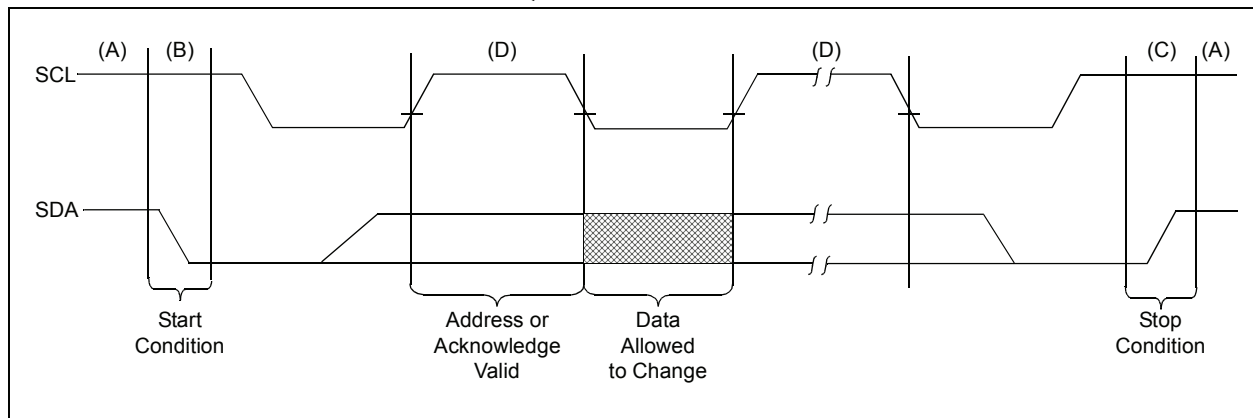

MCP7940X

FIGURE 3-2: ACKNOWLEDGE TIMING

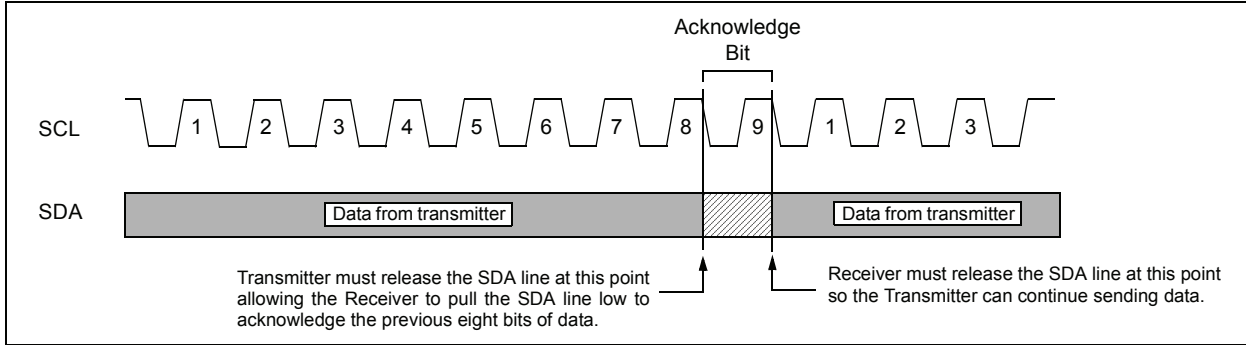

3.1.2 DEVICE ADDRESSING AND OPERATION

A control byte is the first byte received following the Start condition from the master device (Figure 3-2). The control byte consists of a control code; for the MCP7940X this is set as '1010111' for read and write operations for the Unique ID after the correct unlock sequence.

The control byte for accessing the SRAM and RTCC registers are set to '1101111'. The RTCC registers and the SRAM share the same address space.

The last bit of the control byte defines the operation to be performed. When set to a '1' a read operation is selected, and when set to a '0' a write operation is

selected. The next byte received defines the address of the data byte (Figure 3-3). The upper address bits are transferred first, followed by the Least Significant bits (LSb).

Following the Start condition, the MCP7940X monitors the SDA bus, checking the device type identifier being transmitted. Upon receiving an '1010111' or '1101111' code, the slave device outputs an Acknowledge signal on the SDA line. Depending on the state of the R/W bit, the MCP7940X will select a read or write operation.

FIGURE 3-3: ADDRESS SEQUENCE BIT ASSIGNMENTS

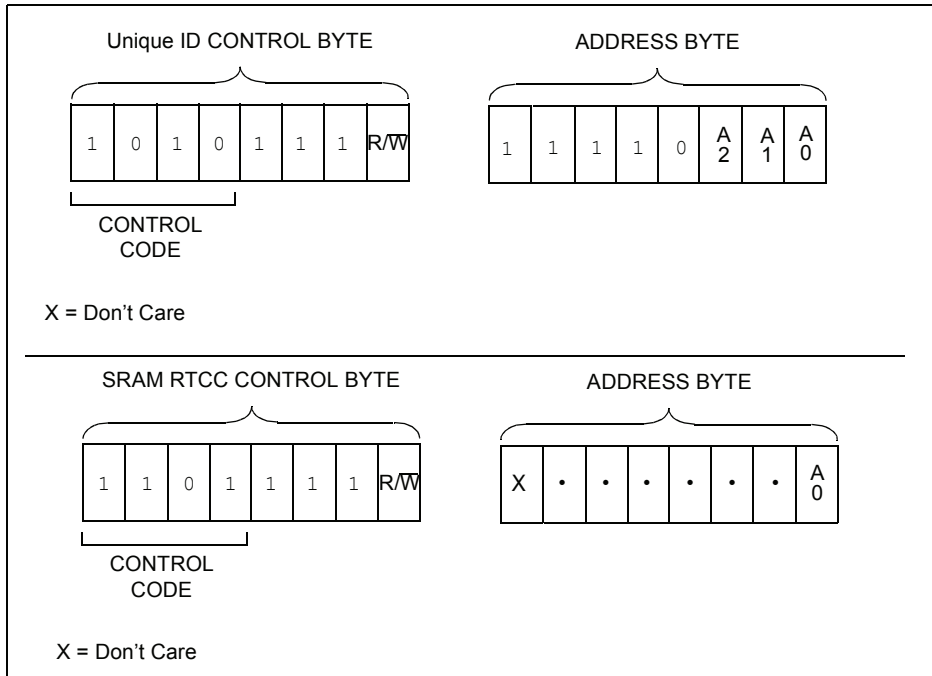

3.1.3 ACKNOWLEDGE POLLING

Since the device will not acknowledge a Unique ID command during an ID write cycle, this can be used to determine when the cycle is complete. This feature can be used to maximize bus throughput. Once the Stop condition for a Write command has been issued from the master, the device initiates the internally timed write cycle. ACK polling can be initiated immediately. This involves the master sending a Start condition, followed by the control byte for a Write command ($R/\overline{W} = 0$). If the device is still busy with the write cycle, then no ACK will be returned. If no ACK is returned, then the Start bit and control byte must be resent. If the cycle is complete, then the device will return the ACK, and the master can then proceed with the next Read or Write command. See [Figure 3-4](#) for the flow diagram.

FIGURE 3-4: ACKNOWLEDGE POLLING FLOW

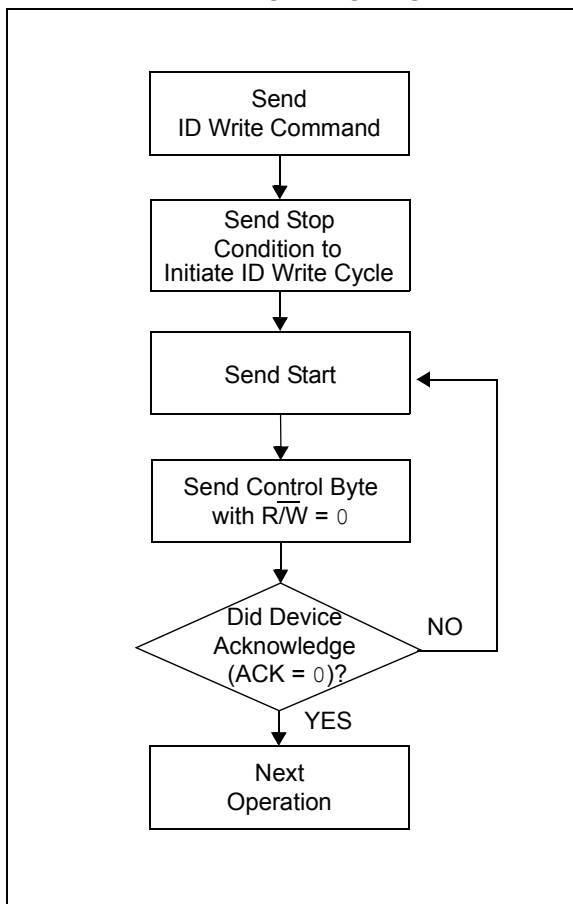

MCP7940X

4.0 RTCC FUNCTIONALITY

The MCP7940X family is a highly integrated RTCC. On-board time and date counters are driven from a low-power oscillator to maintain the time and date. An integrated VCC switch enables the device to maintain the time and date and also the contents of the SRAM during a VCC power failure.

4.1 RTCC MEMORY MAP

The RTCC registers are contained in addresses 0x00h-0x1fh. 64 bytes of user-accessible SRAM are located in the address range 0x20-0x5f. The SRAM memory is a separate block from the RTCC control and Configuration registers. All SRAM locations are battery-backed-up during a VCC power fail. Unused locations are not accessible, MCP7940X will noACK after the address byte if the address is out of range, as shown in the shaded region of the memory map in [Figure 4-1](#). The shaded areas are not implemented and read as '0'. No error checking is provided when loading time and date registers.

- Addresses 0x00h-0x06h are the RTCC Time and Date registers. These are read/write registers. Care must be taken when writing to these registers while the oscillator is running.
- Incorrect data can appear in the Time and Date registers if a write is attempted during the time-frame where these internal registers are being incremented. The user can minimize the likelihood of data corruption by insuring that any writes to the Time and Date registers occur before the contents of the second register reach a value of 0x59H.
- Addresses 0x07h-0x09h are the device Configuration, Calibration and ID Unlock registers.
- Addresses 0x0Ah-0x10h are the Alarm 0 registers. These are used to set up the Alarm 0, the Interrupt polarity and the Alarm 0 compare.
- Addresses 0x11h-0x17h are the same as 0x0Bh-0x11h but are used for Alarm 1.
- Addresses 0x18h-0x1Fh are used for the time-stamp feature.

The detailed memory map is shown in [Table 4-1](#).

FIGURE 4-1: MEMORY MAP

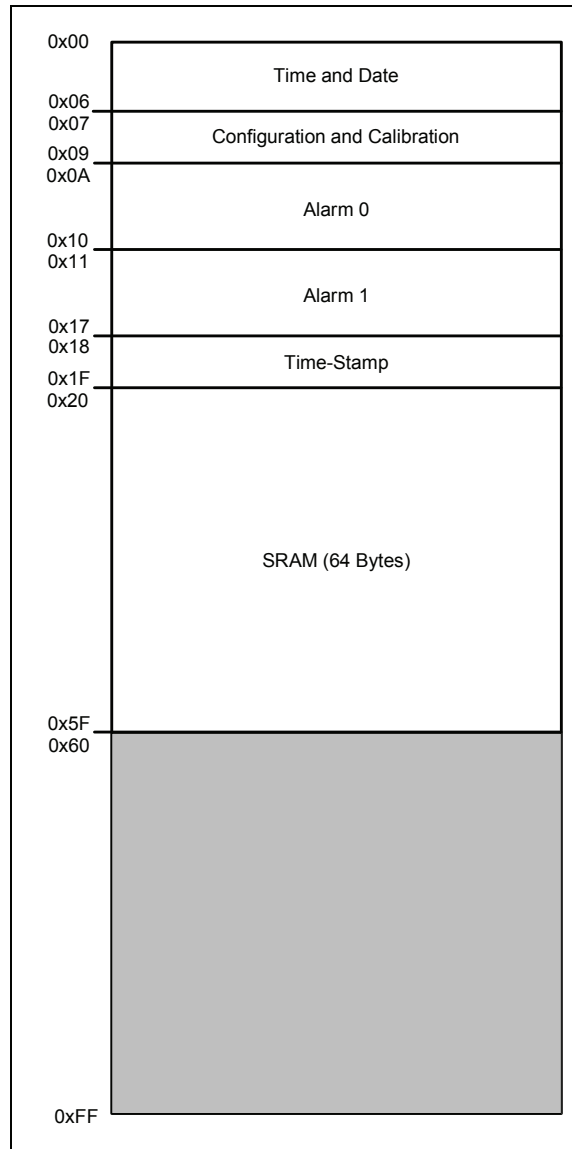

TABLE 4-1: DETAILED RTCC MEMORY MAP

Address	Bit 7	Bit 6	Bit 5	Bit 4	Bit 3	Bit 2	Bit 1	Bit 0	Function	Range	Reset State
00h	ST	10 Seconds			Seconds			Seconds	Seconds	00-59	00h
01h		10 Minutes			Minutes			Minutes	Minutes	00-59	00h
02h		12/24	10 Hour AM/PM	10 Hour	Hour			Hours	Hours	1-12 + AM/PM 00 - 23	00h
03h			OSCON	VBAT	VBATEN	Day			Day	1-7	01h
04h		10 Date			Date			Date	Date	01-31	01h
05h			LP	10 Month	Month			Month	Month	01-12	01h
06h	10 Year				Year			Year	Year	00-99	01h
07h	OUT	SQWE	ALM1	ALM0	EXTOSC	RS2	RS1	RS0	Control Reg.		80h
08h	CALIBRATION								Calibration		00h
09h	UNIQUE UNLOCK ID SEQUENCE								Unlock ID		00h
0Ah		10 Seconds			Seconds			Seconds	Seconds	00-59	00h
0Bh		10 Minutes			Minutes			Minutes	Minutes	00 - 59	00h
0Ch		12/24	10 Hour AM/PM	10 Hours	Hour			Hours	Hours	1-12 + AM/PM 00-23	00h
0Dh	ALM0POL	ALM0C2	ALM0C1	ALM0C0	ALM0IF	Day			Day	1-7	01h
0Eh		10 Date			Date			Date	Date	01-31	01h
0Fh		10 Month			Month			Month	Month	01-12	01h
10h	Reserved – Do not use								Reserved		01h
11h		10 Seconds			Seconds			Seconds	Seconds	00-59	00h
12h		10 Minutes			Minutes			Minutes	Minutes	00-59	00h
13h		12/24	10 Hour AM/PM	10 Hours	Hour			Hours	Hours	1-12 + AM/PM 00-23	00h
14h	ALM1POL	ALM1C2	ALM1C1	ALM1C0	ALM1IF	Day			Day	1-7	01h
15h		10 Date			Date			Date	Date	01-31	01h
16h		10 Month			Month			Month	Month	01-12	01h
17h	Reserved – Do not use								Reserved		01h
18h		10 Minutes			Minutes						00h
19h		12/24	10 Hour AM/PM	10 Hours	Hour						00h
1Ah		10 Date			Date						00h
1Bh	Day			10 Month	Month						00h
1Ch		10 Minutes			Minutes						00h
1Dh		12/24	10 Hour AM/PM	10 Hours	Hour						00h
1Eh		10 Date			Date						00h
1Fh	Day			10 Month	Month						00h

MCP7940X

4.1.1 RTCC REGISTER ADDRESSES

0x00h – Contains the BCD seconds and 10 seconds. The range is 00 to 59. Bit 7 in this register is used to start or stop the on-board crystal oscillator. Setting this bit to a '1' starts the oscillator and clearing this bit to a '0' stops the on-board oscillator.

0x01h – Contains the BCD minutes and 10 minutes. The range is 00 to 59.

0x02h – Contains the BCD hour in bits 3:0. Bits 5:4 contain either the 10 hour in BCD for 24-hour format or the AM/PM indicator and the 10-hour bit for 12-hour format. Bit 6 determines the hour format. Setting this bit to '0' enables 24-hour format, setting this bit to '1' enables 12-hour format.

0x03h – Contains the BCD day. The range is 1-7. Additional bits are also used for configuration and status.

- Bit 3 is the VBATEN bit. If this bit is set, the internal circuitry is connected to the VBAT pin when VCC fails. If this bit is '0' then the VBAT pin is disconnected and the only current drain on the external battery is the VBAT pin leakage.
- Bit 4 is the VBAT bit. This bit is set by hardware when the VCC fails and the VBAT is used to power the Oscillator and the RTCC registers. This bit is cleared by software. Clearing this bit will also clear all the time-stamp registers.
- Bit 5 is the OSCON bit. This is set and cleared by hardware. If this bit is set, the oscillator is running, if cleared, the oscillator is not running. This bit does not indicate that the oscillator is running at the correct frequency. The RTCC will wait 32 oscillator cycles before the bit is set. The RTCC will wait roughly 32 clock cycles to clear this bit.

0x04h – Contains the BCD date and 10 date. The range is 01-31. Bits 5:4 contain 10's date and bits 4:0 contain the date.

0x05h – Contains the BCD month. Bit 4 contains the 10 month. Bit 5 is the Leap Year bit, which is set during a leap year and is read-only.

0x06h – Contains the BCD year and 10 year. The Range is 00-99.

0x07h – Is the Control register.

- Bit 7 is the OUT bit. This sets the logic level on the MFP when not using this as a square wave output.
- Bit 6 is the SQWE bit. Setting this bit enables the divided output from the crystal oscillator.
- Bits 5:4 determine which alarms are active.
 - 00 – No Alarms are active
 - 01 – Alarm 0 is active
 - 10 – Alarm 1 is active
 - 11 – Both Alarms are active
- Bit 3 is the EXTOSC enable bit. Setting this bit will allow an external 32.768 kHz signal to drive the RTCC registers, eliminating the need for an external crystal.
- Bit 2:0 sets the internal divider for the 32.768 kHz oscillator to be driven to the MFP. The duty cycle is 50%. The output is responsive to the Calibration register. The following frequencies are available:
 - 000 – 1 Hz
 - 001 – 4.096 kHz
 - 010 – 8.192 kHz
 - 011 – 32.768 kHz
- 1xx enables the Cal output function. Cal output appears on MFP if SQWE is set (64 Hz Nominal). See [Section 4.2.2 "Calibration"](#) for more details.

Note: The RTCC counters will continue to increment during the calibration.

0x08h is the Calibration register. This is an 8-bit register that is used to add or subtract clocks from the RTCC counter every minute. The MSB is the sign bit and indicates if the count should be added or subtracted. The remaining 7 bits, with each bit adding or subtracting 2 clocks, give the user the ability to add or subtract up to 254 clocks per minute.

0x09h is the unlock sequence address. To unlock write access to the unique ID area in the EEPROM, a sequence must be written to this address in separate commands. The process is fully detailed in [Section 4.2.1 "Unlock Sequence"](#).

0x0Ah-0x0fh and 0x11-0x16h are the Alarm 0 and Alarm 1 registers. The bits are the same as the RTCC bits with the following differences:

Locations 0x10h and 0x17h are reserved and should not be used to allow for future device compatibility.

0x0Dh/0x14h has additional bits for alarm configuration.

- ALMxPOL: This bit specifies the level that the MFP will drive when the alarm is triggered. ALM2POL is a copy of ALM1POL. The default state of the MFP when used for alarms is the inverse of ALM1POL.
- ALMxIF: This is the Alarm Interrupt Flag. This bit is set in hardware if the alarm was triggered. The bit is cleared in software.

- ALMxC2:0: These Configuration bits determine the alarm match. The logic will trigger the alarm based on one of the following match conditions:

- 000 – Seconds match
- 001 – Minutes match
- 010 – Hours match (takes into account 12/24 hour)
- 011 – Matches the current day, interrupt at 12.00.00 a.m. Example: 12 midnight on
- 100 – Date
- 101 – RESERVED
- 110 – RESERVED
- 111 – Seconds, Minutes, Hour, Day, Date, Month

- The 12/24-hour bits 0xCh.6 and 0x13h.6 are copies of the bit in 0x02h.6. The bits are read-only.

0x18h-0x1Bh are used for the timesaver function. These registers are loaded at the time when VCC fails and the RTCC operates on the VBAT. The VBAT bit is also set at this time. These registers are cleared when the VBAT bit is cleared in software.

0x1Ch-0x1Fh are used for the timesaver function. These registers are loaded at the time when VCC is restored and the RTCC switches to VDD. These registers are cleared when the VBAT bit is cleared in software.

Note: It is strongly recommended that the timesaver function only be used when the oscillator is running. This will ensure accurate functionality.

4.2 FEATURES

4.2.1 UNLOCK SEQUENCE

The unique ID location is user accessible by using the unlock ID sequence.

The unique ID location is 64-bits (8 bytes) and is stored in EEPROM locations 0xF0 to 0xF7. This location can be read at any time, however, a write is inhibited until unlocked.

To unlock the write access to this location the following sequence must be completed:

- A single write of 0x55h to address 0x09. Stop
- A single write of 0xAAh to address 0x09. Stop

This will allow the unique EEPROM locations to be written.

After the byte or page write to these locations, the write sequence is initiated by the Stop condition. At this time, the ID locations are locked and no further writes are possible to this location unless a complete unlock sequence is repeated.

MCP7940X

4.2.2 CALIBRATION

The MCP7940X utilizes digital calibration to correct for inaccuracies of the input clock source (either external or crystal). Calibration is enabled by setting the value of the Calibration register at address 08H. Calibration is achieved by adding or subtracting a number of input clock cycles per minute in order to achieve ppm level adjustments in the internal timing function of the MCP7940X.

The MSB of the Calibration register is the sign bit, with a '1' indicating subtraction and a '0' indicating addition. The remaining seven bits in the register indicate the number of input clock cycles (multiplied by two) that are subtracted or added per minute to the internal timing function.

The internal timing function can be monitored using the MFP open-drain output pin by setting bit [6] (SQWE) and bits [2:0] (RS2, RS1, RS0) of the control register at address 07H. Note that the MFP output waveform is disabled when the MCP7940X is running in VBAT mode. With the SQWE bit set to '1', there are two methods that can be used to observe the internal timing function of the MCP7940X:

A. RS2 BIT SET TO '0'

With the RS2 bit set to '0', the RS1 and RS0 bits enable the following internal timing signals to be output on the MFP pin:

RS2	RS1	RS0	Output Signal
0	0	0	1 Hz
0	0	1	4.096 kHz
0	1	0	8.192 kHz
0	1	1	32.768 kHz

The frequencies listed in the table presume an input clock source of exactly 32.768 kHz. In terms of the equivalent number of input clock cycles, the table becomes:

RS2	RS1	RS0	Output Signal
0	0	0	32768
0	0	1	8
0	1	0	4
0	1	1	1

With regards to the calibration function, the Calibration register setting has no impact upon the MFP output clock signal when bits RS1 and RS0 are set to '11'. The setting of the Calibration register to a non-zero value (i.e., values other than 00H or 80H) enables the calibration function which can be observed on the MFP output pin. The calibration function can be expressed in terms of the number of input clock cycles added/subtracted from the internal timing function.

With bits RS1 and RS0 set to '00', the calibration function can be expressed as:

$$T_{\text{output}} = (32768 \pm (2 * \text{CALREG})) T_{\text{input}}$$

where:

$$T_{\text{output}} = \text{clock period of MFP output signal}$$

$$T_{\text{input}} = \text{clock period of input signal}$$

$$\text{CALREG} = \text{decimal value of Calibration register setting and the sign is determined by the MSB of Calibration register.}$$

Since the calibration is done once per minute (i.e., when the internal minute counter is incremented), only one cycle in sixty of the MFP output waveform is affected by the calibration setting. Also note that the duty cycle of the MFP output waveform will not necessarily be at 50% when the calibration setting is applied.

With bits RS1 and RS0 set to '01' or '10', the calibration function can not be expressed in terms of the input clock period. In the case where the MSB of the Calibration register is set to '0', the waveform appearing at the MFP output pin will be "delayed", once per minute, by twice the number of input clock cycles defined in the Calibration register. The MFP waveform will appear as:

FIGURE 4-2: RS1 AND RS0 WITH AND WITHOUT CALIBRATION

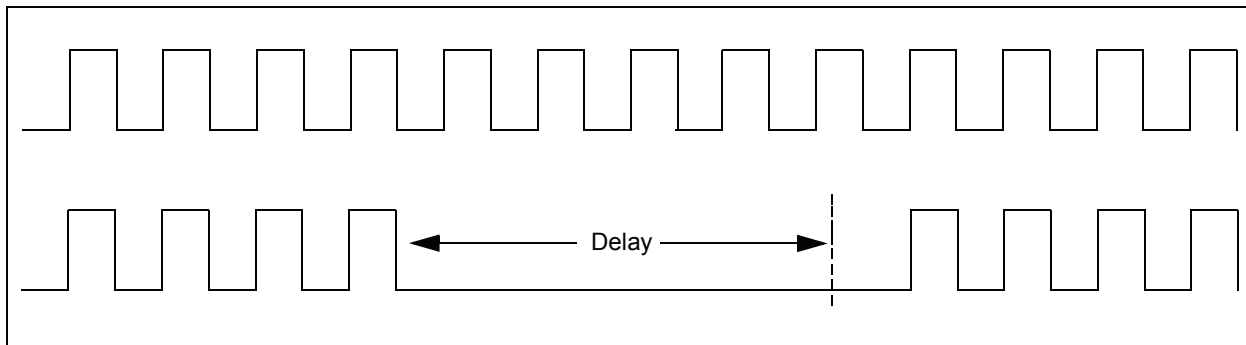

In the case where the MSB of the Calibration register is set to '1', the MFP output waveforms that appear when bits RS1 and RS0 are set to '01' or '10' are not as responsive to the setting of the Calibration register. For example, when outputting the 4.096 kHz waveform (RS1, RS0 set to '01'), the output waveform is generated using only eight input clock cycles. Consequently, attempting to subtract more than eight input clock cycles from this output does not have a meaningful effect on the resulting waveform. Any effect on the output will appear as a modification in both the frequency and duty cycle of the waveform appearing on the MFP output pin.

B.RS2 BIT SET TO '1'

With the RS2 bit set to '1', the following internal timing signal is output on the MFP pin:

RS2	RS1	RS0	Output Signal
1	x	x	64.0 Hz

The frequency listed in the table presumes an input clock source of exactly 32.768 kHz. In terms of the equivalent number of input clock cycles, the table becomes:

RS2	RS1	RS0	Output Signal
1	x	x	512

Unlike the method previously described, the calibration setting is continuously applied and affects every cycle of the output waveform. This results in the modulation of the frequency of the output waveform based upon the setting of the Calibration register.

Using this setting, the calibration function can be expressed as:

$$T_{\text{output}} = (2 * (256 +/- (2 * \text{CALREG}))) T_{\text{input}}$$

where:

$$T_{\text{output}} = \text{clock period of MFP output signal}$$

$$T_{\text{input}} = \text{clock period of input signal}$$

$$\text{CALREG} = \text{decimal value of the Calibration register setting, and the sign is determined by the MSB of the Calibration register.}$$

Since the calibration is done every cycle, the frequency of the output MFP waveform is constant.

4.2.3 MFP

Pin 7 is a multi-function pin and supports the following functions:

- Use of the OUT bit in the Control register for single bit I/O
- Alarm Outputs – Available in VBAT mode
- FOUT mode – driven from a FOSC divider – Not available in VBAT mode

The internal control logic for the MFP is connected to the switched internal supply bus, this allows operation in VBAT mode. The Alarm Output is the only mode that operates in VBAT mode, other modes are suspended.

4.2.4 VBAT

The MCP7940X features an internal switch that will power the clock and the SRAM. In the event that the VCC supply is not available, the voltage applied to the VBAT pin serves as the backup supply. A low-value series resistor is recommended between the external battery and the VBAT pin to limit the current to the internal switch circuit.

The VBAT trip point is the point at which the internal switch operates the device from the VBAT supply and is typically 1.5V (VTRIP specification D12) typical. When VDD falls below 1.5V the system will continue to operate the RTCC and SRAM using the VBAT supply. The following conditions apply:

TABLE 4-2:

Supply Condition	Read/Write Access	Powered By
VCC < VTRIP, VCC < VBAT	No	VBAT
VCC > VTRIP, VCC < VBAT	Yes	VCC
VCC > VTRIP, VCC > VBAT	Yes	VCC

If the VBAT feature is not being used, the VBAT pin must be connected to GND. For more information on VBAT conditions see AN1365, "RTCC Best Practices Application Note" (DS01365).

MCP7940X

4.2.5 CRYSTAL SPECS

The MCP7940X has been designed to operate with a standard 32.768 kHz tuning fork crystal. The on-board oscillator has been characterized to operate with a crystal of maximum ESR of 70K Ohms.

Crystals with a comparable specification are also suitable for use with the MCP7940X.

The table below is given as design guidance and a starting point for crystal and capacitor selection.

Manufacturer	Part Number	Crystal Capacitance	CX1 Value	CX2 Value
Micro Crystal	CM7V-T1A	7pF	10pF	12pF
Citizen	CM200S-32.768KDZB-UT	6pF	10pF	8 pF

Please work with your crystal vendor.

EQUATION 4-1:

$$C_{load} = \frac{CX2 \times CX1}{CX2 + CX1} + C_{stray}$$

The following must also be taken into consideration:

- Pin capacitance (to be included in Cx2 and Cx1)
- Stray Board Capacitance

The recommended board layout for the oscillator area is shown in Figure 4-3. This actual board shows the crystal and the load capacitors. In this example, C2 is CX1, C3 is CX2 and the crystal is designated as Y1.

FIGURE 4-3: BOARD LAYOUT

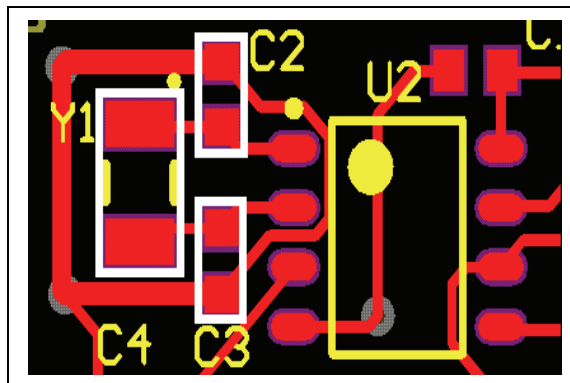

Gerber files are available from www.microchip.com/rfcc.

It is required that the final application should be tested with the chosen crystal and capacitor combinations across all operating and environmental conditions. Please also consult with the crystal specification to observe correct handling and reflow conditions and for information on ideal capacitor values.

For more information please see AN1365, "RTCC Best Practices Application Note" (DS01365).

4.2.6 POWER-FAIL TIME-STAMP

The MCP7941X family of RTCC devices feature a power-fail time-stamp feature. This feature will store the time at which VCC crosses the VTRIP voltage and is shown in Figure 4-4. To use this feature, a VBAT supply must be present and the oscillator must also be running.

There are two separate sets of registers that are used to record this information:

- The first set, located at 0x18h through 0x1Bh, is loaded at the time when VCC falls below VTRIP and the RTCC operates on the VBAT. The VBAT (register 0x03h bit 4) bit is also set at this time.
- The second set of registers, located at 0x1Ch through 0x1Fh, is loaded at the time when VCC is restored and the RTCC switches to VCC.

The power-fail time-stamp registers are cleared when the VBAT bit is cleared in software.

FIGURE 4-4: POWER-FAIL GRAPH

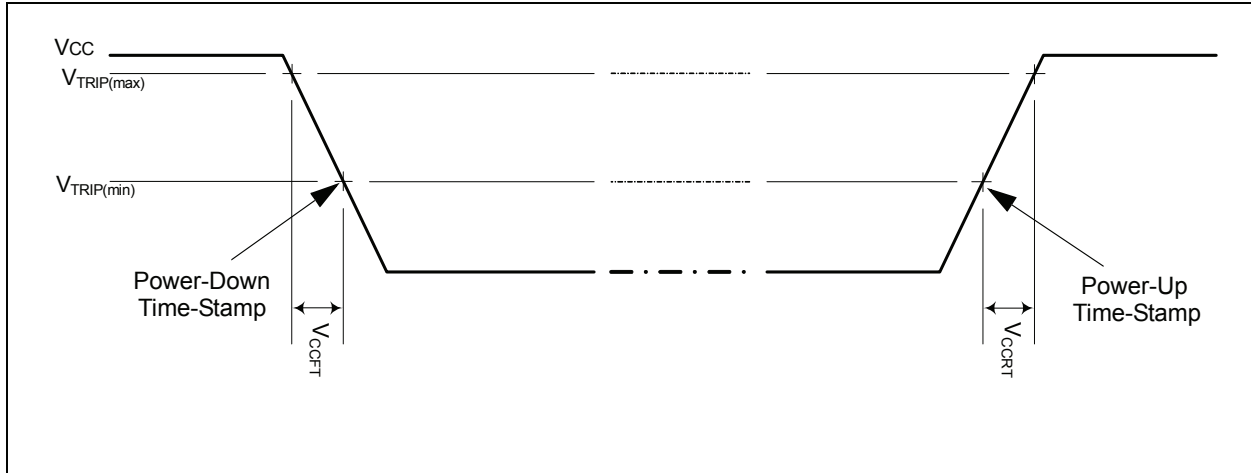

MCP7940X

5.0 ON BOARD MEMORY

The MCP7940X has both on-board Unique ID memory and battery-backed SRAM. The SRAM is arranged as 64 x 8 bytes and is retained when the Vcc supply is

removed, provided the VBAT supply is present and enabled. The Unique ID is nonvolatile memory and does not require the VBAT supply for retention.

5.1 SRAM

FIGURE 5-1: SRAM/RTCC BYTE WRITE

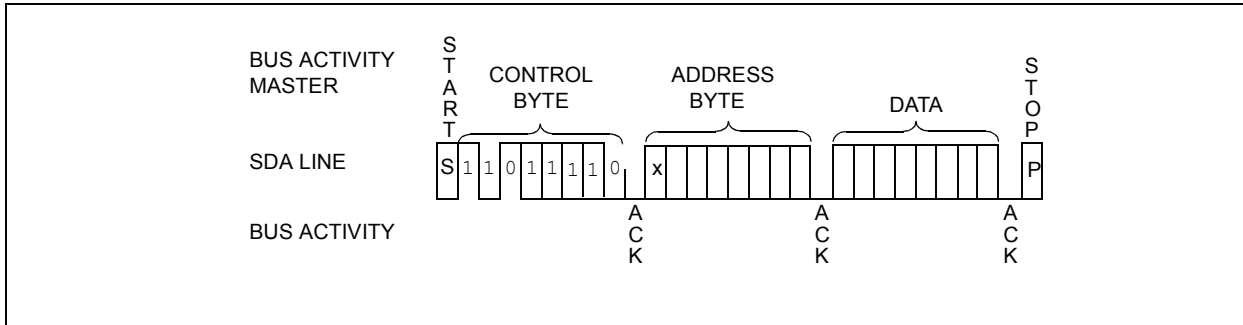
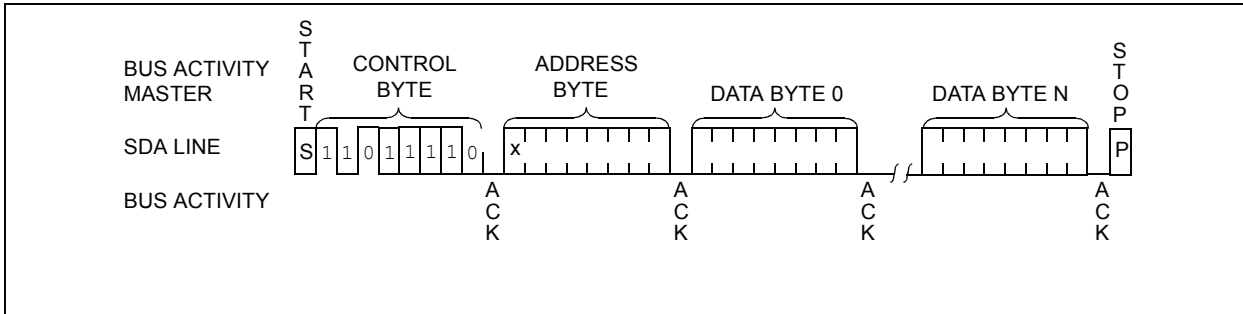

FIGURE 5-2: SRAM/RTCC MULTIPLE BYTE WRITE



The 64 bytes of user SRAM are at location 0x20h and can be accessed during an RTCC update. Upon POR the SRAM will be in an undefined state.

Writing to the SRAM and RTCC is accomplished in a similar way to writing to the EEPROM (as described later in this document) with the following considerations:

- There is no page. The entire 64 bytes of SRAM or 32 bytes of RTCC register can be written in one command.
- The SRAM allows an unlimited number of read/write cycles with no cell wear out.
- The RTCC and SRAM are not accessible when the device is running on the external VBAT.
- The RTCC and SRAM are separate blocks. The SRAM array may be accessed during an RTCC update.
- Read and write access is limited to either the RTCC register block or the SRAM array. The Address Pointer will rollover to the start of the addressed block.
- Data written to the RTCC and SRAM are on a per byte basis.

Note: Entering an address past 5F for an SRAM operation will result in the MCP7940X not acknowledging the address.

5.2 ID

5.2.1 ID BYTE WRITE

Following the Start condition from the master, the control code and the R/W bit (which is a logic low) are clocked onto the bus by the master transmitter. This indicates to the addressed slave receiver that a byte with a word address will follow after it has generated an Acknowledge bit during the ninth clock cycle. Therefore, the next byte transmitted by the master is the word address and will be written into the Address Pointer of the MCP7940X. After receiving another Acknowledge signal from the MCP7940X, the master device transmits the data word to be written into the addressed memory location. The MCP7940X acknowledges again and the master generates a Stop condition. This initiates the internal write cycle, and, during this time, the MCP7940X does not generate Acknowledge signals for Unique ID Write commands. If an attempt is made to write to an address and the protection is set then the device will acknowledge the command but no write cycle will occur, no data will be written, and the device will immediately accept a new command. After a Byte Write command, the internal address counter will point to the address location following the one that was just written.

<p>Note: Addressing undefined ID locations will result in the MCP7940X not acknowledging the address.</p>
--

MCP7940X

FIGURE 5-3: ID BYTE WRITE

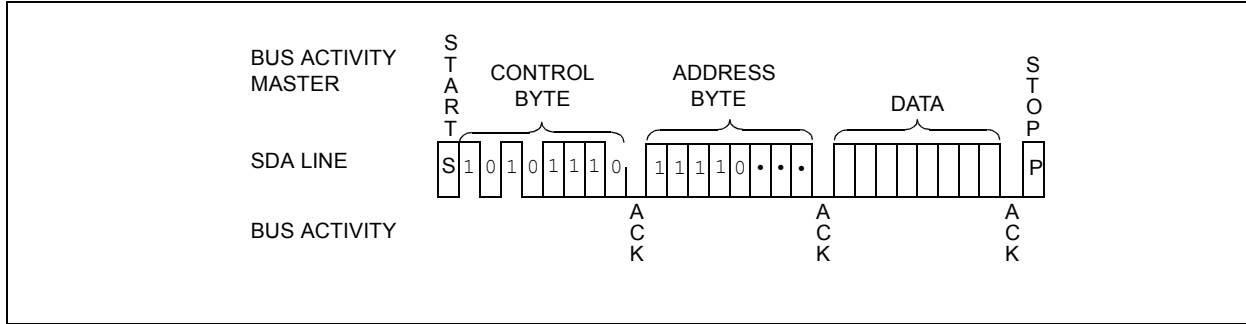

5.2.2 READ OPERATION

Read operations are initiated in the same way as write operations with the exception that the R/\overline{W} bit of the control byte is set to one. There are three basic types of read operations: current address read, random read, and sequential read. The SRAM array can be read in the same way as the ID using the control byte for the SRAM '1101111' with a valid address.

5.2.2.1 Current Address Read

The MCP7940X contains an address counter that maintains the address of the last word accessed, internally incremented by one. Therefore, if the previous read access was to address n (n is any legal address), the next current address read operation would access data from address $n + 1$.

Upon receipt of the control byte with R/\overline{W} bit set to one, the MCP7940X issues an Acknowledge and transmits the 8-bit data word. The master will not acknowledge the transfer but does generate a Stop condition and the MCP7940X discontinues transmission (Figure 5-4).

FIGURE 5-4: CURRENT ADDRESS READ (ID SHOWN)

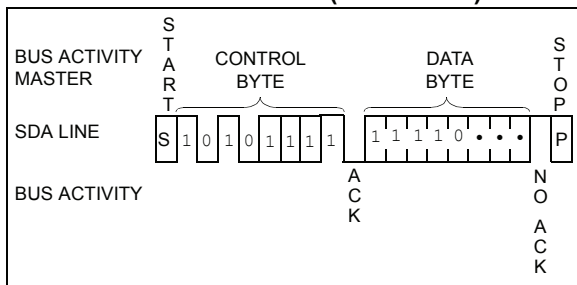

5.2.2.2 Random Read

Random read operations allow the master to access any memory location in a random manner. To perform this type of read operation, first the word address must be set. This is done by sending the word address to the MCP7940X as part of a write operation (R/\overline{W} bit set to '0'). After the word address is sent, the master generates a Start condition following the Acknowledge. This terminates the write operation, but not before the internal Address Pointer is set. Then, the master issues

the control byte again but with the R/\overline{W} bit set to a one. The MCP7940X will then issue an Acknowledge and transmit the 8-bit data word. The master will not acknowledge the transfer but it does generate a Stop condition which causes the MCP7940X to discontinue transmission (Figure 5-5). After a random read command, the internal address counter will point to the address location following the one that was just read.

5.2.2.3 Sequential Read

Sequential reads are initiated in the same way as a random read except that after the MCP7940X transmits the first data byte, the master issues an Acknowledge as opposed to the Stop condition used in a random read. This Acknowledge directs the MCP7940X to transmit the next sequentially addressed 8-bit word (Figure 5-6). Following the final byte transmitted to the master, the master will NOT generate an Acknowledge but will generate a Stop condition. To provide sequential reads, the MCP7940X contains an internal Address Pointer which is incremented by one at the completion of each operation. This Address Pointer allows the entire memory contents to be serially read during one operation. The internal Address Pointer will automatically roll over to the start of the block.

FIGURE 5-5: RANDOM READ (UNIQUE ID SHOWN)

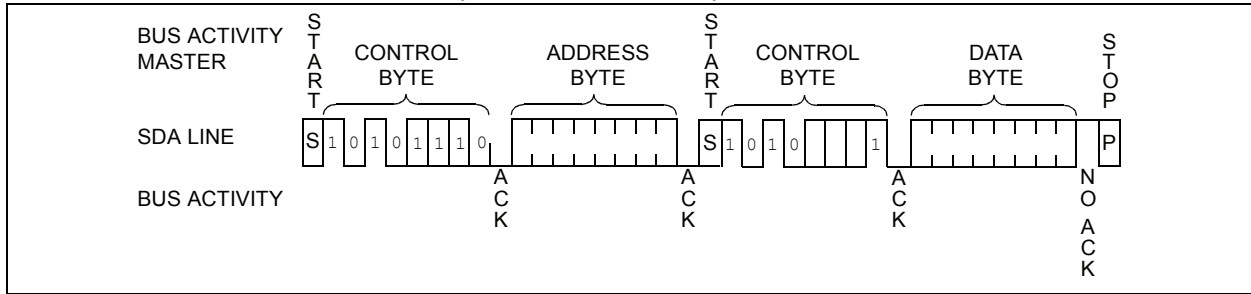
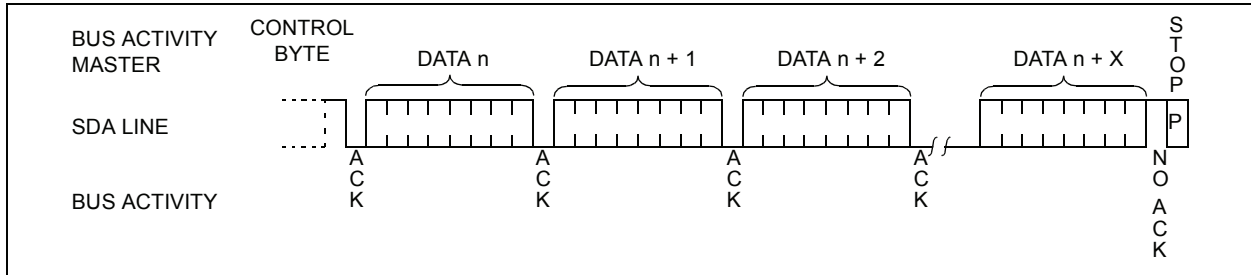

FIGURE 5-6: SEQUENTIAL READ (UNIQUE ID SHOWN)



5.3 Unique ID

The MCP7940X features an additional 64-bit unique ID area.

The unique ID is located at addresses 0xF0 through 0xF7. Reading the unique ID requires the user to simply address these bytes.

The unique ID area is protected to prevent unintended writes to these locations. The unlock sequence is detailed in Section 4.2.1 “Unlock Sequence”.

The unique ID can be factory programmed on some devices to provide a unique IEEE EUI-48 or EUI-64 value. In addition, customer-provided codes can also be programmed.

MCP7940X

6.0 PACKAGING INFORMATION

6.1 Package Marking Information

8-Lead SOIC (3.90 mm)

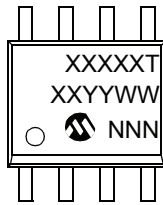

Example:

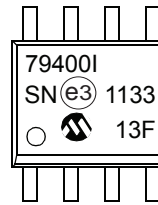

8-Lead TSSOP

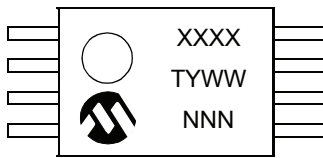

Example:

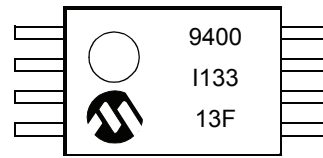

8-Lead MSOP

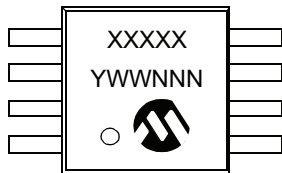

Example:

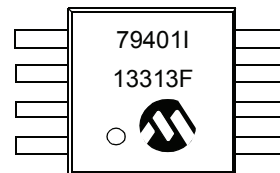

8-Lead 2x3 TDFN

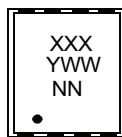

Example:

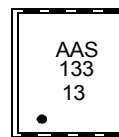

Part Number	1st Line Marking Codes		
	TSSOP	MSOP	TDFN
MCP79400	9400	79400T	AAS
MCP79401	9401	79401T	AAT
MCP79402	9402	79402T	AAU

Note: T = Temperature grade
 NN = Alphanumeric traceability code

Legend: XX...X Customer-specific information
 Y Year code (last digit of calendar year)
 YY Year code (last 2 digits of calendar year)
 WW Week code (week of January 1 is week '01')
 NNN Alphanumeric traceability code
 (e3) Pb-free JEDEC designator for Matte Tin (Sn)
 * This package is Pb-free. The Pb-free JEDEC designator (e3) can be found on the outer packaging for this package.

Note: In the event the full Microchip part number cannot be marked on one line, it will be carried over to the next line, thus limiting the number of available characters for customer-specific information.

8-Lead Plastic Small Outline (SN) - Narrow, 3.90 mm Body [SOIC]

Note: For the most current package drawings, please see the Microchip Packaging Specification located at <http://www.microchip.com/packaging>

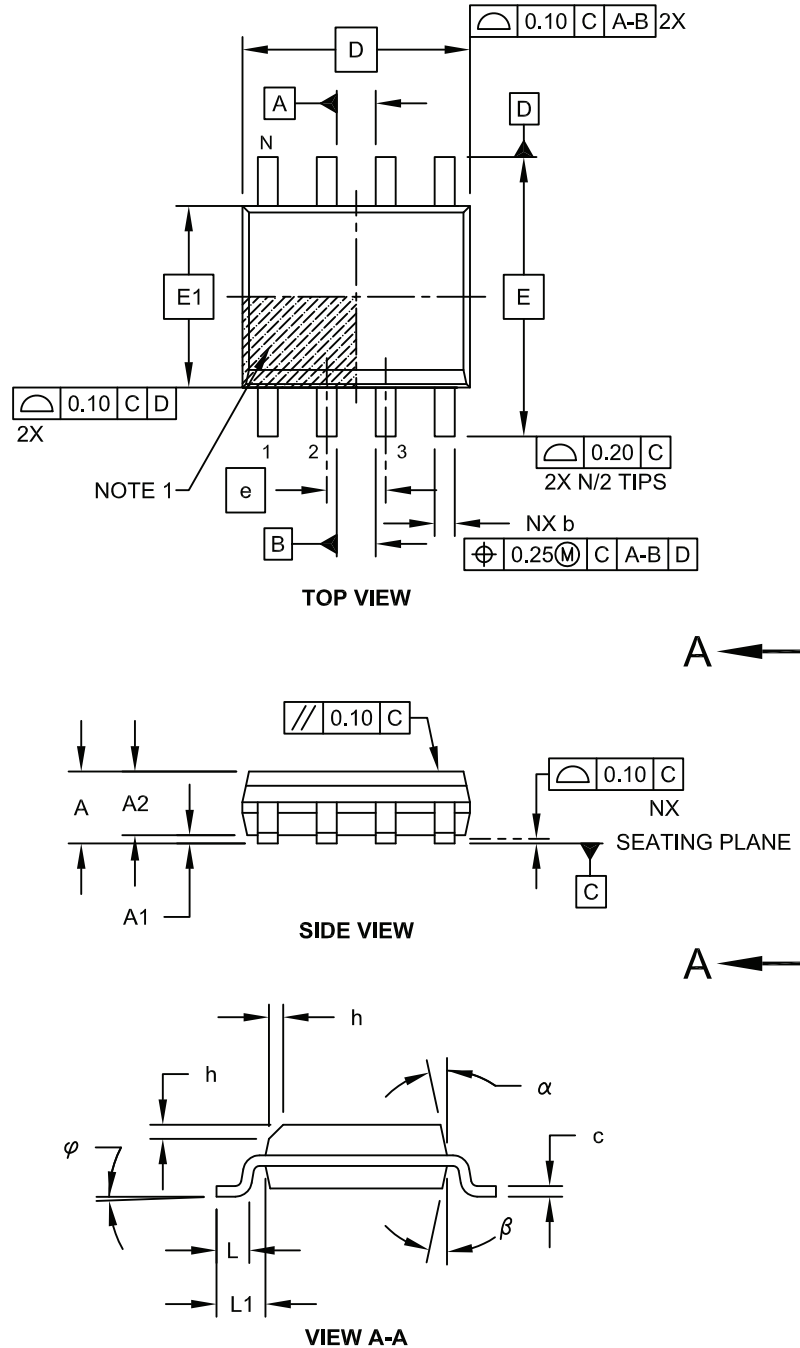

Microchip Technology Drawing No. C04-057C Sheet 1 of 2

MCP7940X

8-Lead Plastic Small Outline (SN) - Narrow, 3.90 mm Body [SOIC]

Note: For the most current package drawings, please see the Microchip Packaging Specification located at <http://www.microchip.com/packaging>

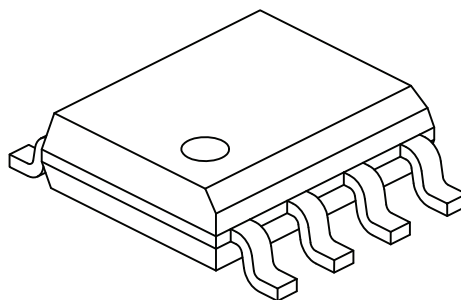

Dimension Limits	Units	MILLIMETERS		
		MIN	NOM	MAX
Number of Pins	N	8		
Pitch	e	1.27 BSC		
Overall Height	A	-	-	1.75
Molded Package Thickness	A2	1.25	-	-
Standoff §	A1	0.10	-	0.25
Overall Width	E	6.00 BSC		
Molded Package Width	E1	3.90 BSC		
Overall Length	D	4.90 BSC		
Chamfer (Optional)	h	0.25	-	0.50
Foot Length	L	0.40	-	1.27
Footprint	L1	1.04 REF		
Foot Angle	φ	0°	-	8°
Lead Thickness	c	0.17	-	0.25
Lead Width	b	0.31	-	0.51
Mold Draft Angle Top	α	5°	-	15°
Mold Draft Angle Bottom	β	5°	-	15°

Notes:

1. Pin 1 visual index feature may vary, but must be located within the hatched area.
2. § Significant Characteristic
3. Dimensions D and E1 do not include mold flash or protrusions. Mold flash or protrusions shall not exceed 0.15mm per side.
4. Dimensioning and tolerancing per ASME Y14.5M

BSC: Basic Dimension. Theoretically exact value shown without tolerances.

REF: Reference Dimension, usually without tolerance, for information purposes only.

Microchip Technology Drawing No. C04-057C Sheet 2 of 2

8-Lead Plastic Small Outline (SN) – Narrow, 3.90 mm Body [SOIC]

Note: For the most current package drawings, please see the Microchip Packaging Specification located at <http://www.microchip.com/packaging>

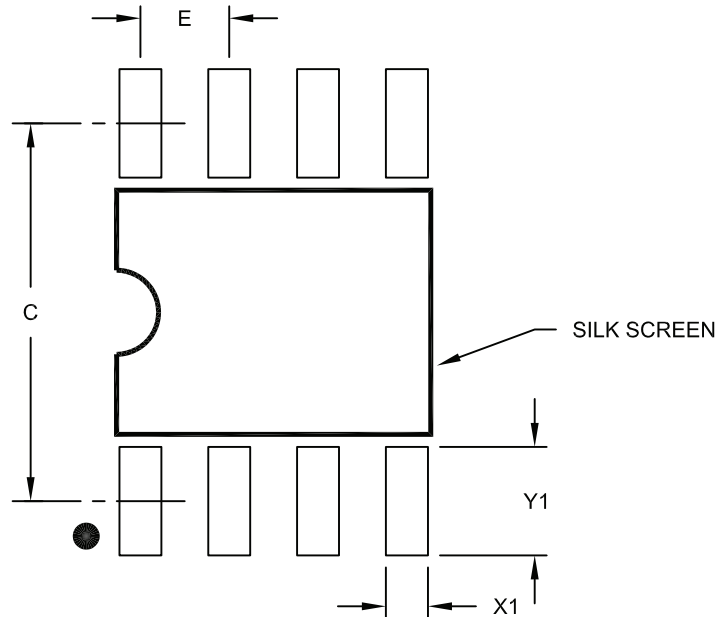

RECOMMENDED LAND PATTERN

Dimension Limits	Units	MILLIMETERS		
		MIN	NOM	MAX
Contact Pitch	E		1.27 BSC	
Contact Pad Spacing	C		5.40	
Contact Pad Width (X8)	X1			0.60
Contact Pad Length (X8)	Y1			1.55

Notes:

1. Dimensioning and tolerancing per ASME Y14.5M

BSC: Basic Dimension. Theoretically exact value shown without tolerances.

Microchip Technology Drawing No. C04-2057A

MCP7940X

8-Lead Plastic Thin Shrink Small Outline (ST) – 4.4 mm Body [TSSOP]

Note: For the most current package drawings, please see the Microchip Packaging Specification located at <http://www.microchip.com/packaging>

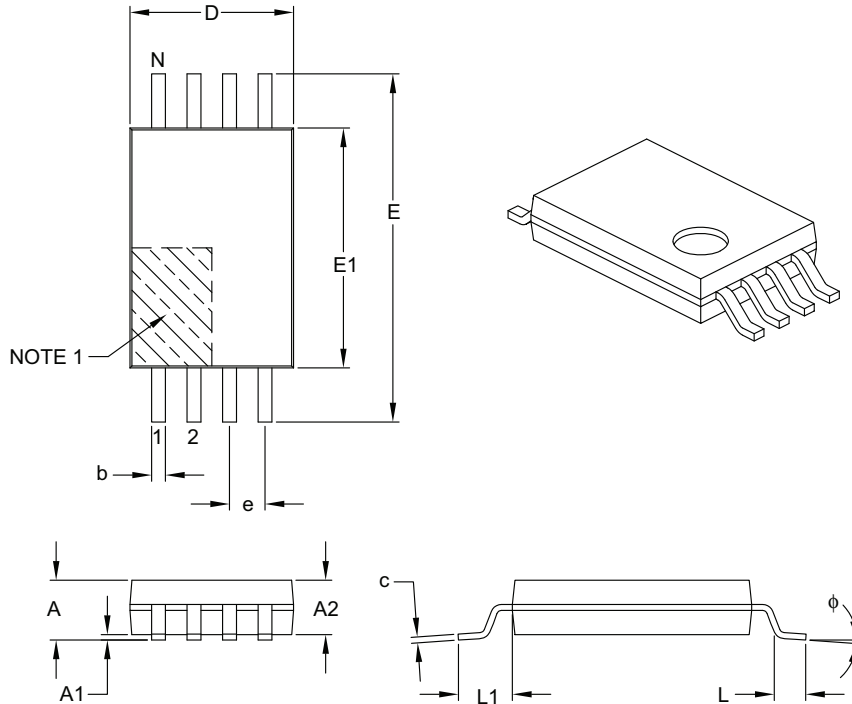

Dimension Limits	Units	MILLIMETERS		
		MIN	NOM	MAX
Number of Pins	N	8		
Pitch	e	0.65 BSC		
Overall Height	A	–	–	1.20
Molded Package Thickness	A2	0.80	1.00	1.05
Standoff	A1	0.05	–	0.15
Overall Width	E	6.40 BSC		
Molded Package Width	E1	4.30	4.40	4.50
Molded Package Length	D	2.90	3.00	3.10
Foot Length	L	0.45	0.60	0.75
Footprint	L1	1.00 REF		
Foot Angle	ϕ	0°	–	8°
Lead Thickness	c	0.09	–	0.20
Lead Width	b	0.19	–	0.30

Notes:

- Pin 1 visual index feature may vary, but must be located within the hatched area.
- Dimensions D and E1 do not include mold flash or protrusions. Mold flash or protrusions shall not exceed 0.15 mm per side.
- Dimensioning and tolerancing per ASME Y14.5M.

BSC: Basic Dimension. Theoretically exact value shown without tolerances.

REF: Reference Dimension, usually without tolerance, for information purposes only.

Microchip Technology Drawing C04-086B

8-Lead Plastic Thin Shrink Small Outline (ST) - 4.4 mm Body [TSSOP]

Note: For the most current package drawings, please see the Microchip Packaging Specification located at <http://www.microchip.com/packaging>

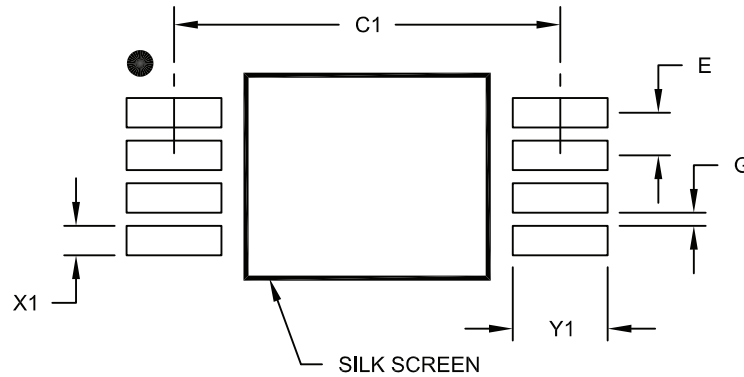

RECOMMENDED LAND PATTERN

Dimension Limits	Units	MILLIMETERS		
		MIN	NOM	MAX
Contact Pitch	E	0.65 BSC		
Contact Pad Spacing	C1		5.90	
Contact Pad Width (X8)	X1			0.45
Contact Pad Length (X8)	Y1			1.45
Distance Between Pads	G	0.20		

Notes:

1. Dimensioning and tolerancing per ASME Y14.5M

BSC: Basic Dimension. Theoretically exact value shown without tolerances.

Microchip Technology Drawing No. C04-2086A

MCP7940X

8-Lead Plastic Micro Small Outline Package (MS) [MSOP]

Note: For the most current package drawings, please see the Microchip Packaging Specification located at <http://www.microchip.com/packaging>

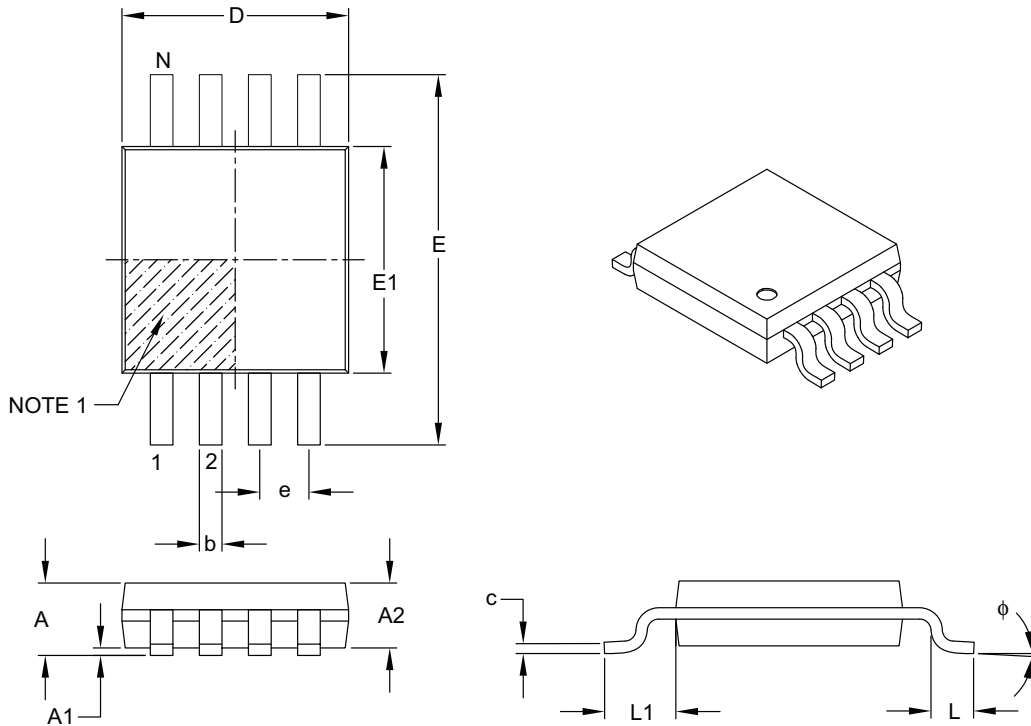

Dimension Limits	Units	MILLIMETERS		
		MIN	NOM	MAX
Number of Pins	N	8		
Pitch	e	0.65 BSC		
Overall Height	A	–	–	1.10
Molded Package Thickness	A2	0.75	0.85	0.95
Standoff	A1	0.00	–	0.15
Overall Width	E	4.90 BSC		
Molded Package Width	E1	3.00 BSC		
Overall Length	D	3.00 BSC		
Foot Length	L	0.40	0.60	0.80
Footprint	L1	0.95 REF		
Foot Angle	ϕ	0°	–	8°
Lead Thickness	c	0.08	–	0.23
Lead Width	b	0.22	–	0.40

Notes:

- Pin 1 visual index feature may vary, but must be located within the hatched area.
- Dimensions D and E1 do not include mold flash or protrusions. Mold flash or protrusions shall not exceed 0.15 mm per side.
- Dimensioning and tolerancing per ASME Y14.5M.

BSC: Basic Dimension. Theoretically exact value shown without tolerances.

REF: Reference Dimension, usually without tolerance, for information purposes only.

Microchip Technology Drawing C04-111B

8-Lead Plastic Micro Small Outline Package (MS) [MSOP]

Note: For the most current package drawings, please see the Microchip Packaging Specification located at <http://www.microchip.com/packaging>

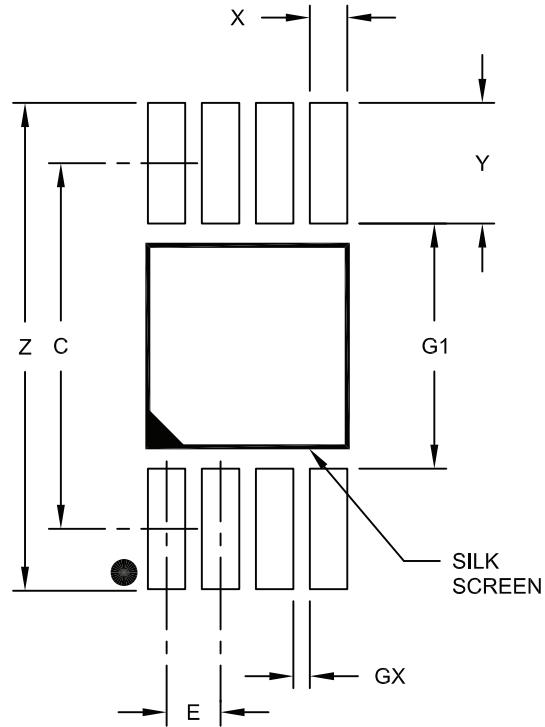

RECOMMENDED LAND PATTERN

Dimension Limits	Units	MILLIMETERS		
		MIN	NOM	MAX
Contact Pitch	E	0.65 BSC		
Contact Pad Spacing	C		4.40	
Overall Width	Z			5.85
Contact Pad Width (X8)	X1			0.45
Contact Pad Length (X8)	Y1			1.45
Distance Between Pads	G1	2.95		
Distance Between Pads	GX	0.20		

Notes:

1. Dimensioning and tolerancing per ASME Y14.5M

BSC: Basic Dimension. Theoretically exact value shown without tolerances.

Microchip Technology Drawing No. C04-2111A

MCP7940X

8-Lead Plastic Dual Flat, No Lead Package (MN) – 2x3x0.75mm Body [TDFN]

Note: For the most current package drawings, please see the Microchip Packaging Specification located at <http://www.microchip.com/packaging>

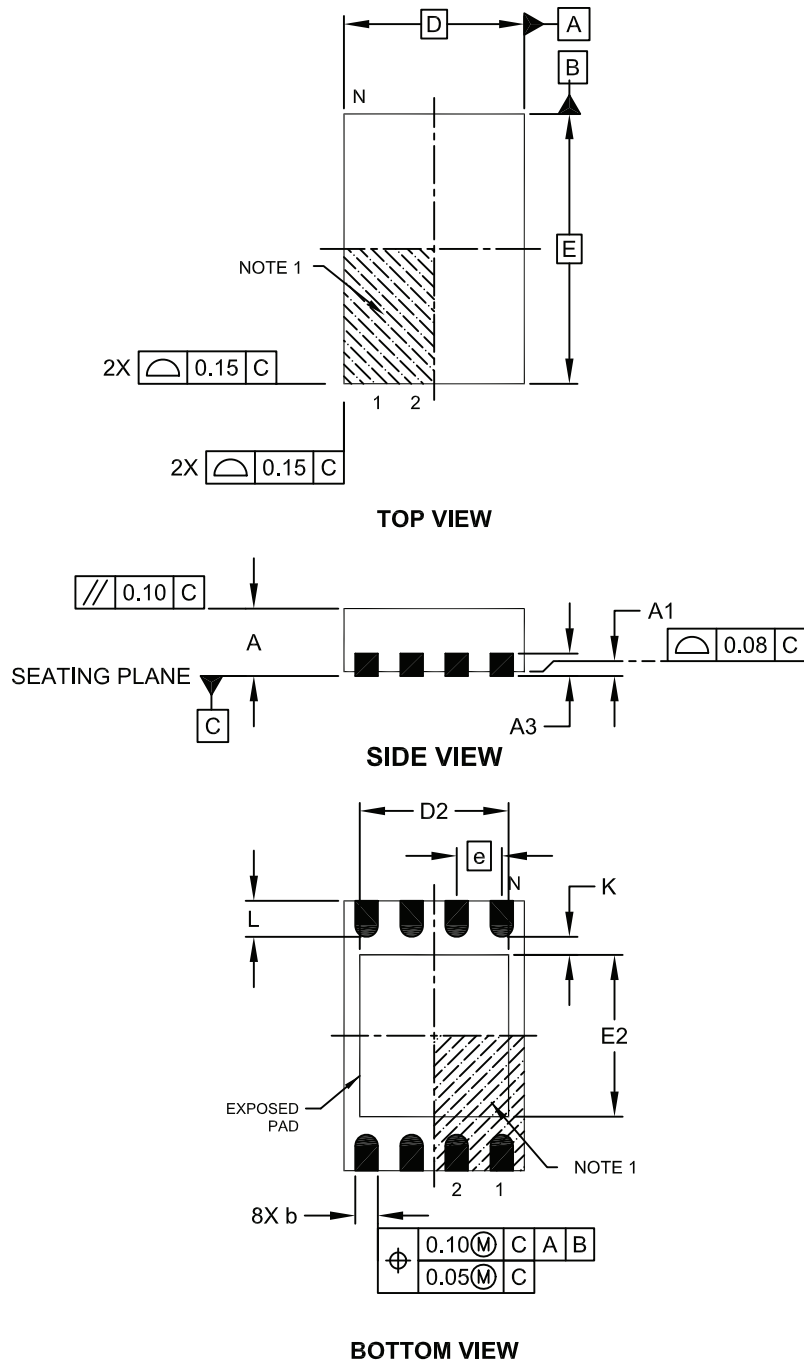

Microchip Technology Drawing No. C04-129C Sheet 1 of 2

8-Lead Plastic Dual Flat, No Lead Package (MN) – 2x3x0.75mm Body [TDFN]

Note: For the most current package drawings, please see the Microchip Packaging Specification located at <http://www.microchip.com/packaging>

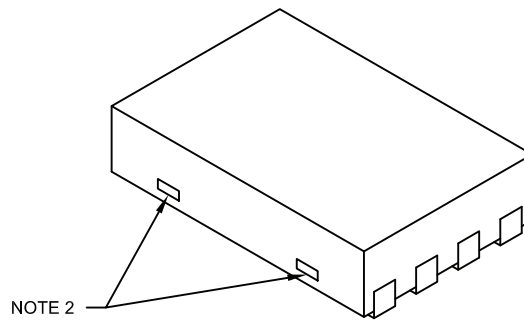

Dimension Limits	Units	MILLIMETERS		
		MIN	NOM	MAX
Number of Pins	N	8		
Pitch	e	0.50 BSC		
Overall Height	A	0.70	0.75	0.80
Standoff	A1	0.00	0.02	0.05
Contact Thickness	A3	0.20 REF		
Overall Length	D	2.00 BSC		
Overall Width	E	3.00 BSC		
Exposed Pad Length	D2	1.20	-	1.60
Exposed Pad Width	E2	1.20	-	1.60
Contact Width	b	0.20	0.25	0.30
Contact Length	L	0.25	0.30	0.45
Contact-to-Exposed Pad	K	0.20	-	-

Notes:

1. Pin 1 visual index feature may vary, but must be located within the hatched area.
2. Package may have one or more exposed tie bars at ends.
3. Package is saw singulated
4. Dimensioning and tolerancing per ASME Y14.5M

BSC: Basic Dimension. Theoretically exact value shown without tolerances.

REF: Reference Dimension, usually without tolerance, for information purposes only.

Microchip Technology Drawing No. C04-129C Sheet 2 of 2

MCP7940X

8-Lead Plastic Dual Flat, No Lead Package (MN) – 2x3x0.75 mm Body [TDFN]

Note: For the most current package drawings, please see the Microchip Packaging Specification located at <http://www.microchip.com/packaging>

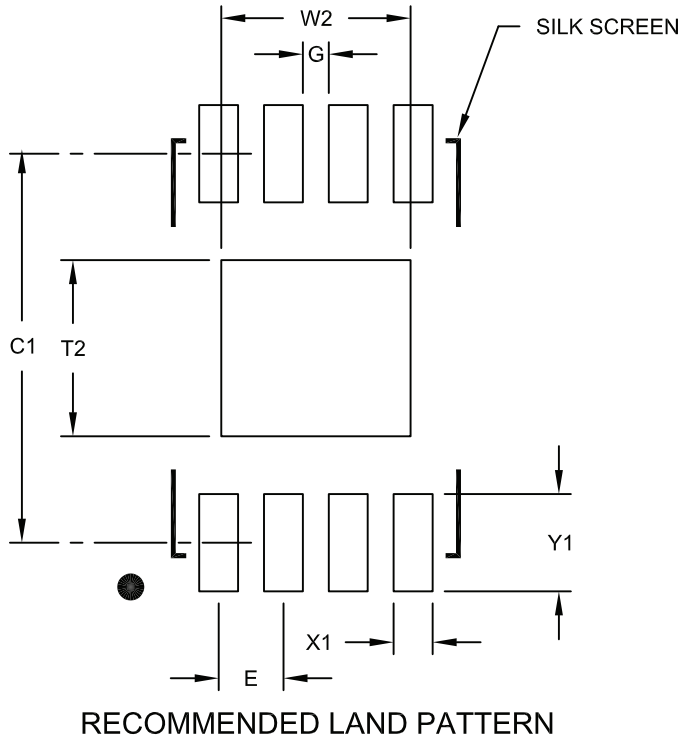

Dimension	Units	MILLIMETERS		
		MIN	NOM	MAX
Dimension Limits				
Contact Pitch	E	0.50 BSC		
Optional Center Pad Width	W2			1.46
Optional Center Pad Length	T2			1.36
Contact Pad Spacing	C1		3.00	
Contact Pad Width (X8)	X1			0.30
Contact Pad Length (X8)	Y1			0.75
Distance Between Pads	G	0.20		

Notes:

1. Dimensioning and tolerancing per ASME Y14.5M

BSC: Basic Dimension. Theoretically exact value shown without tolerances.

Microchip Technology Drawing No. C04-2129A

APPENDIX A: REVISION HISTORY

Revision A (04/2011)

Original release of this document.

Revision B (08/2011)

Added Figure 1-2; Added Parameter D16 to Table 1-1;
Added Sections 2.3-2.5; Added Figure 4.1; Revised
Section 4.1.1; Revised Sections 4.2.4-4.2.6.

MCP7940X

NOTES:

THE MICROCHIP WEB SITE

Microchip provides online support via our WWW site at www.microchip.com. This web site is used as a means to make files and information easily available to customers. Accessible by using your favorite Internet browser, the web site contains the following information:

- **Product Support** – Data sheets and errata, application notes and sample programs, design resources, user's guides and hardware support documents, latest software releases and archived software
- **General Technical Support** – Frequently Asked Questions (FAQ), technical support requests, online discussion groups, Microchip consultant program member listing
- **Business of Microchip** – Product selector and ordering guides, latest Microchip press releases, listing of seminars and events, listings of Microchip sales offices, distributors and factory representatives

CUSTOMER CHANGE NOTIFICATION SERVICE

Microchip's customer notification service helps keep customers current on Microchip products. Subscribers will receive e-mail notification whenever there are changes, updates, revisions or errata related to a specified product family or development tool of interest.

To register, access the Microchip web site at www.microchip.com. Under "Support", click on "Customer Change Notification" and follow the registration instructions.

CUSTOMER SUPPORT

Users of Microchip products can receive assistance through several channels:

- Distributor or Representative
- Local Sales Office
- Field Application Engineer (FAE)
- Technical Support
- Development Systems Information Line

Customers should contact their distributor, representative or field application engineer (FAE) for support. Local sales offices are also available to help customers. A listing of sales offices and locations is included in the back of this document.

Technical support is available through the web site at: <http://microchip.com/support>

MCP79400/MCP79401/MCP79402

READER RESPONSE

It is our intention to provide you with the best documentation possible to ensure successful use of your Microchip product. If you wish to provide your comments on organization, clarity, subject matter, and ways in which our documentation can better serve you, please FAX your comments to the Technical Publications Manager at (480) 792-4150.

Please list the following information, and use this outline to provide us with your comments about this document.

TO: Technical Publications Manager Total Pages Sent _____

RE: Reader Response

From: Name _____

Company _____

Address _____

City / State / ZIP / Country _____

Telephone: (_____) _____ - _____ FAX: (_____) _____ - _____

Application (optional):

Would you like a reply? Y N

Device: MCP7940X

Literature Number: DS25009B

Questions:

1. What are the best features of this document?

2. How does this document meet your hardware and software development needs?

3. Do you find the organization of this document easy to follow? If not, why?

4. What additions to the document do you think would enhance the structure and subject?

5. What deletions from the document could be made without affecting the overall usefulness?

6. Is there any incorrect or misleading information (what and where)?

7. How would you improve this document?

PRODUCT IDENTIFICATION SYSTEM

To order or obtain information, e.g., on pricing or delivery, refer to the factory or the listed sales office. Not every possible ordering combination is listed below.

<u>PART NO.</u>	<u>X</u>	<u>/XX</u>
Device	Temperature Range	Package
<p>Device:</p> <p>MCP79400 = 1.8V - 5.5V I²C™ Serial RTCC MCP79400T = 1.8V - 5.5V I²C Serial RTCC (Tape and Reel) MCP79401 = 1.8V - 5.5V I²C Serial RTCC, EUI-48™ MCP79401T = 1.8V - 5.5V I²C Serial RTCC, EUI-48™ (Tape and Reel) MCP79402 = 1.8V - 5.5V I²C Serial RTCC, EUI-64™ MCP79402T = 1.8V - 5.5V I²C Serial RTCC, EUI-64™ (Tape and Reel)</p> <p>Temperature Range:</p> <p>I = -40°C to +85°C</p> <p>Package:</p> <p>SN = 8-Lead Plastic Small Outline (3.90 mm body) ST = 8-Lead Plastic Thin Shrink Small Outline (4.4 mm) MS = 8-Lead Plastic Micro Small Outline MNY⁽¹⁾ = 8-Lead Plastic Dual Flat, No Lead</p>		
<p>Examples:</p> <p>a) MCP79400-I/SN: Industrial Temperature, SOIC package. b) MCP79400T-I/SN: Industrial Temperature, SOIC package, Tape and Reel. c) MCP79400T-I/MNY: Industrial Temperature, TDFN package. d) MCP79401-I/SN: Industrial Temperature, SOIC package, EUI-48™. e) MCP79401-I/MS: Industrial Temperature MSOP package, EUI-48™. f) MCP79402-I/SN: Industrial Temperature, SOIC package, EUI-64™. g) MCP79402-I/ST: Industrial Temperature, TSSOP package, EUI-64™. h) MCP79402-I/ST: Industrial Temperature, TSSOP package, Tape and Reel, EUI-64™.</p>		
<p>Note 1: 'Y' indicates a Nickel Palladium Gold (NiPdAu) finish.</p>		

MCP7940X

NOTES:

Note the following details of the code protection feature on Microchip devices:

- Microchip products meet the specification contained in their particular Microchip Data Sheet.
- Microchip believes that its family of products is one of the most secure families of its kind on the market today, when used in the intended manner and under normal conditions.
- There are dishonest and possibly illegal methods used to breach the code protection feature. All of these methods, to our knowledge, require using the Microchip products in a manner outside the operating specifications contained in Microchip's Data Sheets. Most likely, the person doing so is engaged in theft of intellectual property.
- Microchip is willing to work with the customer who is concerned about the integrity of their code.
- Neither Microchip nor any other semiconductor manufacturer can guarantee the security of their code. Code protection does not mean that we are guaranteeing the product as "unbreakable."

Code protection is constantly evolving. We at Microchip are committed to continuously improving the code protection features of our products. Attempts to break Microchip's code protection feature may be a violation of the Digital Millennium Copyright Act. If such acts allow unauthorized access to your software or other copyrighted work, you may have a right to sue for relief under that Act.

Information contained in this publication regarding device applications and the like is provided only for your convenience and may be superseded by updates. It is your responsibility to ensure that your application meets with your specifications. MICROCHIP MAKES NO REPRESENTATIONS OR WARRANTIES OF ANY KIND WHETHER EXPRESS OR IMPLIED, WRITTEN OR ORAL, STATUTORY OR OTHERWISE, RELATED TO THE INFORMATION, INCLUDING BUT NOT LIMITED TO ITS CONDITION, QUALITY, PERFORMANCE, MERCHANTABILITY OR FITNESS FOR PURPOSE. Microchip disclaims all liability arising from this information and its use. Use of Microchip devices in life support and/or safety applications is entirely at the buyer's risk, and the buyer agrees to defend, indemnify and hold harmless Microchip from any and all damages, claims, suits, or expenses resulting from such use. No licenses are conveyed, implicitly or otherwise, under any Microchip intellectual property rights.

Trademarks

The Microchip name and logo, the Microchip logo, dsPIC, KEELOQ, KEELOQ logo, MPLAB, PIC, PICmicro, PICSTART, PIC³² logo, rPIC and UNI/O are registered trademarks of Microchip Technology Incorporated in the U.S.A. and other countries.

FilterLab, Hampshire, HI-TECH C, Linear Active Thermistor, MXDEV, MXLAB, SEEVAL and The Embedded Control Solutions Company are registered trademarks of Microchip Technology Incorporated in the U.S.A.

Analog-for-the-Digital Age, Application Maestro, chipKIT, chipKIT logo, CodeGuard, dsPICDEM, dsPICDEM.net, dsPICworks, dsSPEAK, ECAN, ECONOMONITOR, FanSense, HI-TIDE, In-Circuit Serial Programming, ICSP, Mindi, MiWi, MPASM, MPLAB Certified logo, MPLIB, MPLINK, mTouch, Omniscient Code Generation, PICC, PICC-18, PICDEM, PICDEM.net, PICKit, PICtail, REAL ICE, rLAB, Select Mode, Total Endurance, TSHARC, UniWinDriver, WiperLock and ZENA are trademarks of Microchip Technology Incorporated in the U.S.A. and other countries.

SQTP is a service mark of Microchip Technology Incorporated in the U.S.A.

All other trademarks mentioned herein are property of their respective companies.

© 2011, Microchip Technology Incorporated, Printed in the U.S.A., All Rights Reserved.

 Printed on recycled paper.

ISBN: 978-1-61341-579-5

QUALITY MANAGEMENT SYSTEM
CERTIFIED BY DNV
== ISO/TS 16949:2009 ==

Microchip received ISO/TS-16949:2009 certification for its worldwide headquarters, design and wafer fabrication facilities in Chandler and Tempe, Arizona; Gresham, Oregon and design centers in California and India. The Company's quality system processes and procedures are for its PIC[®] MCUs and dsPIC[®] DSCs, KEELOQ[®] code hopping devices, Serial EEPROMs, microperipherals, nonvolatile memory and analog products. In addition, Microchip's quality system for the design and manufacture of development systems is ISO 9001:2000 certified.



MICROCHIP

Worldwide Sales and Service

AMERICAS

Corporate Office
2355 West Chandler Blvd.
Chandler, AZ 85224-6199
Tel: 480-792-7200
Fax: 480-792-7277
Technical Support:
<http://www.microchip.com/support>
Web Address:
www.microchip.com

Atlanta
Duluth, GA
Tel: 678-957-9614
Fax: 678-957-1455

Boston
Westborough, MA
Tel: 774-760-0087
Fax: 774-760-0088

Chicago
Itasca, IL
Tel: 630-285-0071
Fax: 630-285-0075

Cleveland
Independence, OH
Tel: 216-447-0464
Fax: 216-447-0643

Dallas
Addison, TX
Tel: 972-818-7423
Fax: 972-818-2924

Detroit
Farmington Hills, MI
Tel: 248-538-2250
Fax: 248-538-2260

Indianapolis
Noblesville, IN
Tel: 317-773-8323
Fax: 317-773-5453

Los Angeles
Mission Viejo, CA
Tel: 949-462-9523
Fax: 949-462-9608

Santa Clara
Santa Clara, CA
Tel: 408-961-6444
Fax: 408-961-6445

Toronto
Mississauga, Ontario,
Canada
Tel: 905-673-0699
Fax: 905-673-6509

ASIA/PACIFIC

Asia Pacific Office
Suites 3707-14, 37th Floor
Tower 6, The Gateway
Harbour City, Kowloon
Hong Kong
Tel: 852-2401-1200
Fax: 852-2401-3431

Australia - Sydney
Tel: 61-2-9868-6733
Fax: 61-2-9868-6755

China - Beijing
Tel: 86-10-8569-7000
Fax: 86-10-8528-2104

China - Chengdu
Tel: 86-28-8665-5511
Fax: 86-28-8665-7889

China - Chongqing
Tel: 86-23-8980-9588
Fax: 86-23-8980-9500

China - Hangzhou
Tel: 86-571-2819-3187
Fax: 86-571-2819-3189

China - Hong Kong SAR
Tel: 852-2401-1200
Fax: 852-2401-3431

China - Nanjing
Tel: 86-25-8473-2460
Fax: 86-25-8473-2470

China - Qingdao
Tel: 86-532-8502-7355
Fax: 86-532-8502-7205

China - Shanghai
Tel: 86-21-5407-5533
Fax: 86-21-5407-5066

China - Shenyang
Tel: 86-24-2334-2829
Fax: 86-24-2334-2393

China - Shenzhen
Tel: 86-755-8203-2660
Fax: 86-755-8203-1760

China - Wuhan
Tel: 86-27-5980-5300
Fax: 86-27-5980-5118

China - Xian
Tel: 86-29-8833-7252
Fax: 86-29-8833-7256

China - Xiamen
Tel: 86-592-2388138
Fax: 86-592-2388130

China - Zhuhai
Tel: 86-756-3210040
Fax: 86-756-3210049

ASIA/PACIFIC

India - Bangalore
Tel: 91-80-3090-4444
Fax: 91-80-3090-4123

India - New Delhi
Tel: 91-11-4160-8631
Fax: 91-11-4160-8632

India - Pune
Tel: 91-20-2566-1512
Fax: 91-20-2566-1513

Japan - Yokohama
Tel: 81-45-471- 6166
Fax: 81-45-471-6122

Korea - Daegu
Tel: 82-53-744-4301
Fax: 82-53-744-4302

Korea - Seoul
Tel: 82-2-554-7200
Fax: 82-2-558-5932 or
82-2-558-5934

Malaysia - Kuala Lumpur
Tel: 60-3-6201-9857
Fax: 60-3-6201-9859

Malaysia - Penang
Tel: 60-4-227-8870
Fax: 60-4-227-4068

Philippines - Manila
Tel: 63-2-634-9065
Fax: 63-2-634-9069

Singapore
Tel: 65-6334-8870
Fax: 65-6334-8850

Taiwan - Hsin Chu
Tel: 886-3-5778-366
Fax: 886-3-5770-955

Taiwan - Kaohsiung
Tel: 886-7-536-4818
Fax: 886-7-330-9305

Taiwan - Taipei
Tel: 886-2-2500-6610
Fax: 886-2-2508-0102

Thailand - Bangkok
Tel: 66-2-694-1351
Fax: 66-2-694-1350

EUROPE

Austria - Wels
Tel: 43-7242-2244-39
Fax: 43-7242-2244-393

Denmark - Copenhagen
Tel: 45-4450-2828
Fax: 45-4485-2829

France - Paris
Tel: 33-1-69-53-63-20
Fax: 33-1-69-30-90-79

Germany - Munich
Tel: 49-89-627-144-0
Fax: 49-89-627-144-44

Italy - Milan
Tel: 39-0331-742611
Fax: 39-0331-466781

Netherlands - Drunen
Tel: 31-416-690399
Fax: 31-416-690340

Spain - Madrid
Tel: 34-91-708-08-90
Fax: 34-91-708-08-91

UK - Wokingham
Tel: 44-118-921-5869
Fax: 44-118-921-5820

08/02/11