



High Input Voltage Travel Charger for Single-cell Li-Ion Batteries

The MC34674 is a fully integrated single-cell Li-Ion and Li-Polymer battery charger optimized for travel charger applications. The few external components required include a dual-color LED for charge-status indication, a negative temperature coefficient (NTC) thermistor circuit for setting the charge temperature window, and two decoupling capacitors. The high input voltage, up to 28 V, allows low-cost AC/DC converters to be used for further system cost reduction. A typical charge cycle of the MC34674 includes trickle, constant-current (CC) and constant-voltage (CV) charge modes. The CC-mode current is selectable from 50 mA to 1.05 A with 8% accuracy and the constant-output voltage in the CV-mode is fixed at 4.2 V with 0.4% accuracy over -20°C to 70°C temperature range.

The MC34674 has all the features such as trickle charging for a deeply discharged battery, an internal timer for termination to prevent charging a failed battery, charger current thermal foldback for thermal protection, and smart battery connection verification to prevent charging in case there is no battery connected. It also protects the system with its input over-voltage protection (OVP) feature. In addition, it has a 2.6 V falling power-on-reset (POR) threshold, making it perfect to work with current limited power supplies. When the charger is disabled, the BAT pin leaks less than 1.0 μ A current from the battery. All the above functions are fit into a small 8-lead 2X3 UDFN package.

34674

POWER MANAGEMENT IC



ORDERING INFORMATION		
Device	Temperature Range (T _A)	Package
Refer to Table 1. Device Variations	-40° C to 85° C	8 UDFN-EP

Features

- No external MOSFET, reverse-blocking diode or current-sense resistor are required
- 28 V maximum input voltage rating with 11 V over-voltage protection threshold
- Factory programmable charge current
- Trickle charge for fully discharged batteries
- $\pm 0.4\%$ voltage accuracy over -20°C to 70°C
- Driving a dual-color LED and smart battery connection verification optimized for travel charger applications
- Interface to NTC thermistor
- Internal timer and thermal current limit
- Small 2X3 mm² thermally enhanced UDFN package
- Pb-free packaging designated by suffix code EP

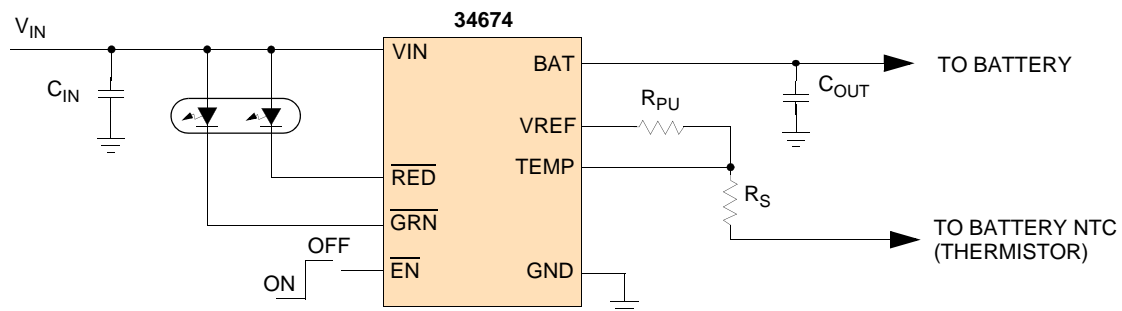

Figure 1. 34674 Simplified Application Diagram

This document contains certain information on a new product. Specifications and information herein are subject to change without notice.

© Freescale Semiconductor, Inc., 2007-8. All rights reserved.



DEVICE VARIATIONS

Table 1. Device Variations

Freescale Part No. ⁽¹⁾	CC-Mode Current (I_{CHG})	Reference Location
MC34674AEP/R2	1.05A	Table 6
MC34674BEP/R2	850mA	Table 6
MC34674CEP/R2	650mA	Table 6
MC34674DEP/R2	450mA	Table 6

Notes

1. Freescale offers a series of MC34674 variations. Each variation has an increment of 50 mA or 100 mA for the CC-mode current.

INTERNAL BLOCK DIAGRAM

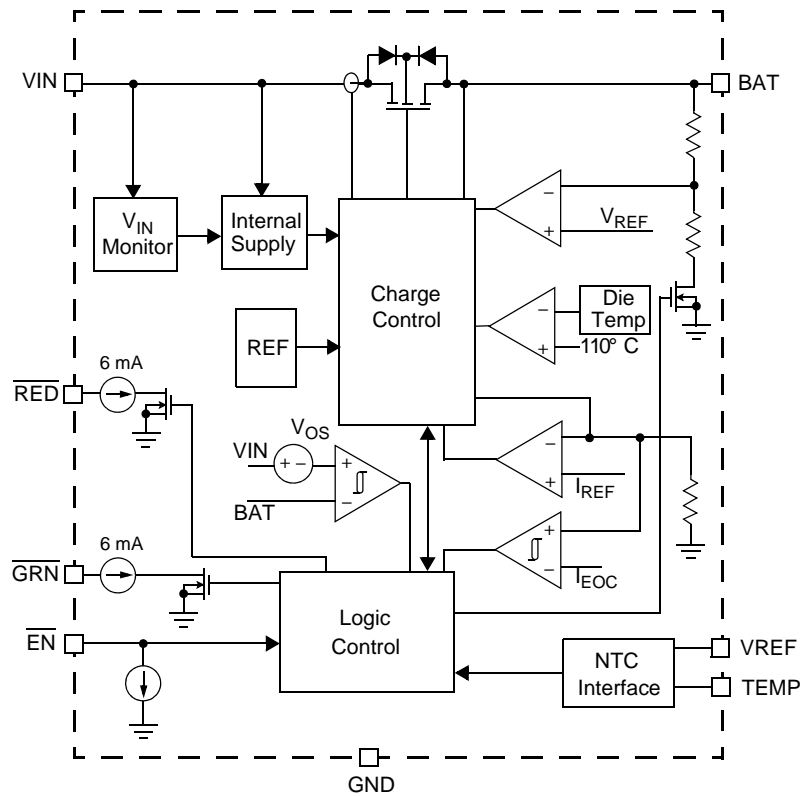

Figure 2. 34674 Simplified Internal Block Diagram

PIN CONNECTIONS

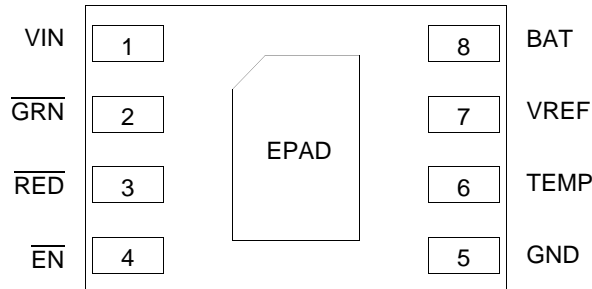

Figure 3. 34674 Pin Connections

Table 2. 34674 Pin Definitions

A functional description of each pin can be found in the Functional Pin Description section beginning on [page 12](#).

Pin Number	Pin Name	Pin Function	Formal Name	Definition
1	VIN	Input	Input supply	The supply input.
2	GRN	Output	Green indicator	Indication of the charge status. Open drain output with 6 mA current limit.
3	RED	Output	Red indicator	Indication of the charge status. Open drain output with 6 mA current limit.
4	EN	Input	Enable	Active-low enable logic input.
5	GND	Ground	Ground	Ground.
6	TEMP	Input	NTC interface input	The NTC thermistor interface pin.
7	VREF	Output	NTC interface bias voltage	The bias voltage for the NTC interface circuit.
8	BAT	Output	Charger output	The charger output pin to the battery.
EPAD	EPAD	N/A	Exposed pad	Exposed pad for thermal dissipation enhancement. Must be soldered on the large ground plane on the PCB to increase the thermal dissipation. The pad must be connected to GND electrically.

ELECTRICAL CHARACTERISTICS

MAXIMUM RATINGS

Table 3. Maximum Ratings

All voltages are with respect to ground unless otherwise noted. Exceeding these ratings may cause a malfunction or permanent damage to the device.

Ratings	Symbol	Value	Unit
ELECTRICAL RATINGS			
Input voltage range VIN Pin GRN and RED Pins EN, BAT, REF and TEMP Pins	V _{IN} V _{GRN} , V _{RED} V _{EN} , V _{BAT} , V _{REF} , V _{TEMP}	-0.3 to 28 -0.3 to 12 -0.3 to 5.5	V
ESD Voltage ⁽²⁾ Human Body Model (HBM) Machine Model (MM)	V _{ESD}	±2000 ±200	V
THERMAL RATINGS			
Operating Temperature Ambient Junction	T _A T _J	-40 to 85 -40 to 150	°C
Storage Temperature	T _{STG}	-65 to 150	°C
Thermal Resistance ⁽³⁾ Junction-to-Case Junction-to-Ambient	R _{θJC} R _{θJA}	10 70	°C/W
Peak Package Reflow Temperature During Reflow ^{(4),(5)}	T _{PPRT}	Note 5	°C

Notes

- ESD testing is performed in accordance with the Human Body Model (HBM) (C_{ZAP} = 100 pF, R_{ZAP} = 1500 Ω), and the Machine Model (MM) (C_{ZAP} = 200 pF, R_{ZAP} = 0 Ω).
- Device mounted on the Freescale EVB test board per JEDEC DESD51-2.
- Pin soldering temperature limit is for 10 seconds maximum duration. Not designed for immersion soldering. Exceeding these limits may cause malfunction or permanent damage to the device.
- Freescale's Package Reflow capability meets Pb-free requirements for JEDEC standard J-STD-020C. For Peak Package Reflow Temperature and Moisture Sensitivity Levels (MSL), Go to www.freescale.com, search by part number [e.g. remove prefixes/suffixes and enter the core ID to view all orderable parts. (i.e. MC33xxxD enter 33xxx), and review parametrics.

STATIC ELECTRICAL CHARACTERISTICS

Table 4. Static Electrical Characteristics

Characteristics noted under conditions $V_{IN} = 5.0\text{ V}$, $-40^{\circ}\text{C} \leq T_A \leq 85^{\circ}\text{C}$, $C_{IN} = C_{OUT} = 1.0\ \mu\text{F}$ (see [Figure 1](#)), unless otherwise noted. Typical values noted reflect the approximate parameter means at $V_{IN} = 5.0\text{ V}$ and $T_A = 25^{\circ}\text{C}$ under nominal conditions, unless otherwise noted.

Characteristic	Symbol	Min	Typ	Max	Unit
POWER INPUT					
Input Voltage Range ⁽⁶⁾	V_{IN}	4.3		10	V
VIN Pin Supply Current	I_{IN}				μA
Charger enabled ⁽⁷⁾		-	1400	-	
Charger disabled		-	300	350	
Power On Reset	V_{POR}				V
Rising V_{IN} threshold		3.0	-	3.9	
Falling V_{IN} threshold		-	2.4	2.6	
Over-voltage Protection Rising Threshold	V_{OVP}	10	11	12	V
Over-voltage-Protection Threshold Hysteresis	V_{OVPHYS}	-	400	-	mV
VIN-BAT Offset Voltage	V_{OS}				mV
Rising threshold		-	-	60	
Falling threshold		1.0	-	22	
OUTPUT					
Regulated Output Voltage ⁽⁸⁾	V_{BAT}				V
$V_{IN} = 5.0\text{ V}$; $I_{BAT} = 10\text{ mA}$; $T_A = 25^{\circ}\text{C}$		4.190	4.20	4.210	
$V_{IN} = 5.0\text{ V}$; $I_{BAT} = 10\text{ mA}$; $T_A = -20\text{ to }70^{\circ}\text{C}$		4.183	4.20	4.217	
$V_{IN} = 5.0\text{ V}$; $I_{BAT} = 10\text{ mA}$; $T_A = -40\text{ to }85^{\circ}\text{C}$		4.179	4.20	4.221	
Power MOSFET On Resistance	$R_{DS(ON)}$				$\text{m}\Omega$
$V_{BAT} = 4.0\text{ V}$; $I_{BAT} = 0.5\text{ A}$; $I_{CHG} = 1.05\text{ A}$		-	265	450	
BAT Pin Standby Current	I_{STDBY}				μA
VIN not powered or charger disabled		-	-	1.0	
VIN powered and in charge completion state (average over 2 seconds) ⁽⁷⁾		-2.0	-	4.0	
CHARGE CURRENT					
Constant-Current-Mode Charge Current	I_{CHG}				mA
MC34674A		966	1050	1134	
MC34674B		782	850	918	
MC34674C		598	650	702	
MC34674D		414	450	486	
Trickle-Mode Charge Current ⁽⁹⁾	I_{TRKL}				I_{CHG}
MC34674A		74	105	136	
MC34674B		60	85	110	
MC34674C		46	65	84	
MC34674D		32	45	58	

Notes

- Refer to the Power-on-Reset parameter for V_{IN} turn on and turn off values.
- Supply current does not include the current delivered to the battery through the BAT pin.
- In the test mode, the charger still operates in CV mode after EOC.
- Characterized over the temperature range $-40^{\circ}\text{C} \leq T_A \leq 85^{\circ}\text{C}$

34674

Table 4. Static Electrical Characteristics (continued)

Characteristics noted under conditions $V_{IN} = 5.0\text{ V}$, $-40^{\circ}\text{C} \leq T_A \leq 85^{\circ}\text{C}$, $C_{IN} = C_{OUT} = 1.0\ \mu\text{F}$ (see [Figure 1](#)), unless otherwise noted. Typical values noted reflect the approximate parameter means at $V_{IN} = 5.0\text{ V}$ and $T_A = 25^{\circ}\text{C}$ under nominal conditions, unless otherwise noted.

Characteristic	Symbol	Min	Typ	Max	Unit
End-of-Charge (EOC) Threshold	I_{EOC}				mA
MC34674A		84	105	126	
MC34674B		68	85	102	
MC34674C		52	65	78	
MC34674D		34	45	57	

CHARGE THRESHOLDS

Trickle-mode Rising Threshold Voltage	V_{TRKL}	2.8	2.9	3.0	V
Trickle-mode Threshold Voltage Hysteresis	$V_{TRKLHYS}$	-	100	-	mV
Recharge Falling Threshold Voltage	V_{RECH}	4.07	4.10	4.135	V
Recharge Threshold Voltage Hysteresis	V_{THRCHG}	-	25	50	mV

BATTERY CONNECTION VERIFICATION

Battery Connection Verification Discharge Current (Over 0.8 to 5.0 V) ⁽¹⁰⁾	I_{DCHG}	4.5	6.0	7.5	mA
Output Current in Charge Completion State ⁽¹⁰⁾	I_{CHGCM}	-	24	-	μA
Discharge Current in Charge Completion State During the 82 ms ⁽¹⁰⁾	I_{DCC}	-	585	-	μA

NTC INTERFACE

Low Temperature Rising Threshold ⁽¹¹⁾	V_{LTRT}	0.6592	2/3	0.6741	VREF
Low Temperature Falling Threshold ⁽¹¹⁾	V_{LTFT}	-	0.6468	-	VREF
High Temperature Falling Threshold ⁽¹¹⁾	V_{HTFT}	0.3297	1/3	0.3389	VREF
High Temperature Rising Threshold ⁽¹¹⁾	V_{HTRT}	-	0.3441	-	VREF
Die Thermal Limit	T_{LIM}	95	110	125	$^{\circ}\text{C}$

LOGIC INPUT AND OUTPUT

$\overline{\text{EN}}$ Input High Threshold Voltage	V_{IH}	1.5	-	-	V
$\overline{\text{EN}}$ Input Low Threshold Voltage	V_{IL}	-	-	0.5	V
$\overline{\text{EN}}$ Pin Internal Pull-down Current	$I_{\overline{\text{EN}}}$	-	2.0	7.5	μA
$\overline{\text{GRN}}$ and $\overline{\text{RED}}$ Sink Current Pin voltage is between 0.8 V and 5.0 V	I_{GRSINK}	5.0	6.0	7.0	mA
Open-Drain Off Leakage Biased at 5.0 V	I_{ODLEAK}	-	-	1.0	μA

Notes

- Not tested. Guaranteed by design.
- These threshold parameters are specified as a ratio of V_{TEMP}/V_{REF} . Due to the negative temperature coefficient thermistor, V_{TEMP} rises when the temperature is falling from high to low, and V_{TEMP} falls when the temperature is rising from low to high.

DYNAMIC ELECTRICAL CHARACTERISTICS

Table 5. Dynamic Electrical Characteristics

Characteristics noted under conditions $V_{IN} = 5.0\text{ V}$, $-40^{\circ}\text{C} \leq T_A \leq 85^{\circ}\text{C}$, $C_{IN} = C_{OUT} = 1.0\ \mu\text{F}$ (see [Figure 1](#)), unless otherwise noted. Typical values noted reflect the approximate parameter means at $V_{IN} = 5.0\text{ V}$ and $T_A = 25^{\circ}\text{C}$ under nominal conditions, unless otherwise noted.

Characteristic	Symbol	Min	Typ	Max	Unit
END OF CHARGE					
EOC Filtering Time ⁽¹²⁾	t_{EOC}	500	-	1000	ms
OSCILLATOR					
Oscillator Frequency	f_{OSC}	40.0	50.0	60.0	kHz
INTERNAL TIMER					
Safety Timer for Fast Charge Mode	t_{FCM}	3.68	4.6	5.52	Hour
Safety Timer for Trickle Charge Mode	t_{TCM}	0.46	0.575	0.69	Hour
ENABLE VERIFICATION					
Enable Verification Time	t_{EV}	-	100	-	ms
BATTERY CONNECTION VERIFICATION					
Discharge Time in Charge Completion State ⁽¹²⁾	t_{DCCC}	-	82	-	ms
Discharge Repeating Time ⁽¹²⁾	t_{DR}	-	1968	-	ms

Notes

12. Not tested. Guaranteed by design.

ELECTRICAL PERFORMANCE CURVES

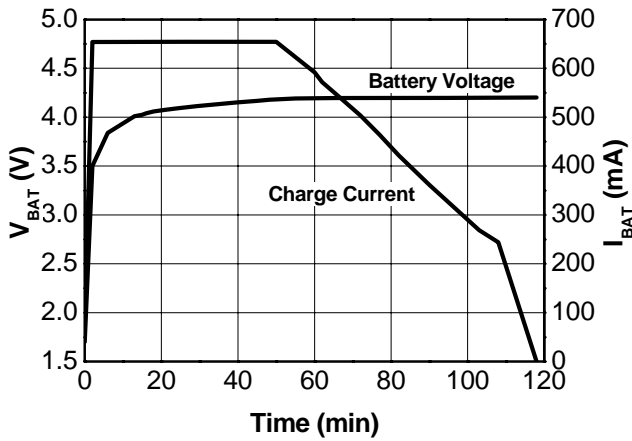

Figure 4. Complete Charge Cycle
 $V_{IN} = 5.0\text{ V}$, $I_{CHG} = 650\text{ mA}$, $T_A = 25^\circ\text{C}$

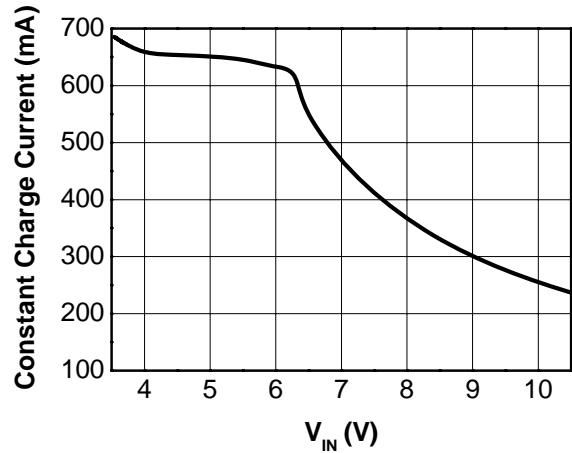

Figure 7. Constant Charge Current vs V_{IN}
 $I_{CHG} = 650\text{ mA}$, $V_{BAT} = 3.0\text{ V}$, $T_A = 25^\circ\text{C}$

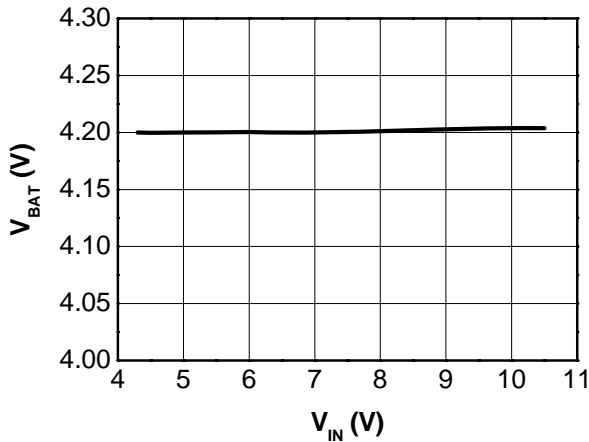

Figure 5. V_{BAT} vs V_{IN}
 $I_{CHG} = 650\text{ mA}$, $I_{BAT} = 0\text{ mA}$, $T_A = 25^\circ\text{C}$

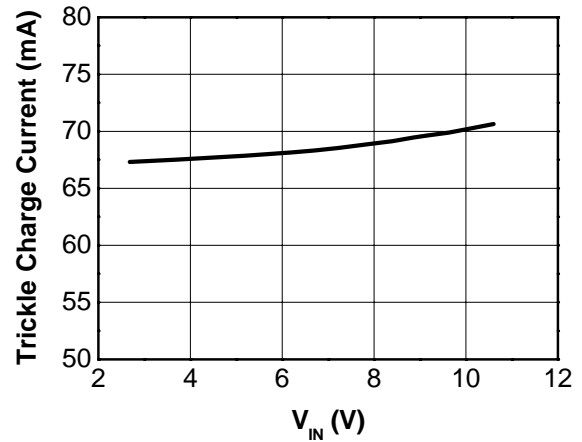

Figure 8. Trickle Charge Current vs V_{IN}
 $I_{CHG} = 650\text{ mA}$, $V_{BAT} = 2.0\text{ V}$, $T_A = 25^\circ\text{C}$

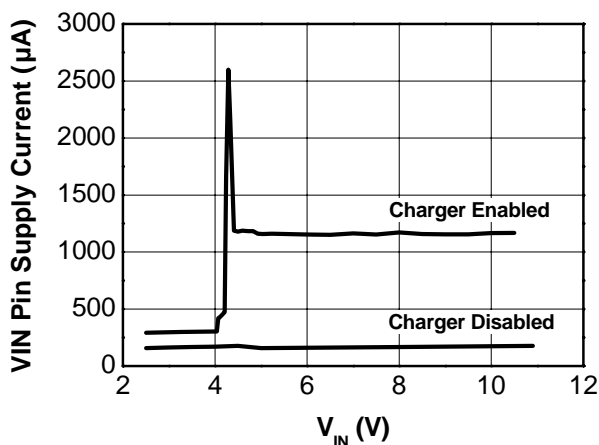

Figure 6. V_{IN} Pin Supply Current vs V_{IN}
 $I_{CHG} = 650\text{ mA}$, $I_{BAT} = 100\text{ mA}$, $T_A = 25^\circ\text{C}$

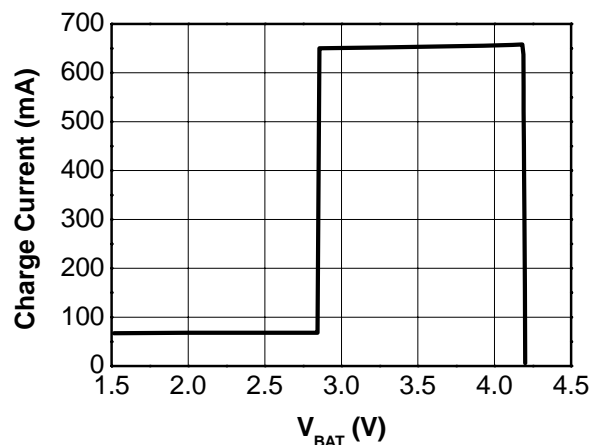

Figure 9. Charge Current vs V_{BAT}
 $I_{CHG} = 650\text{ mA}$, $V_{IN} = 5.0\text{ V}$, $T_A = 25^\circ\text{C}$

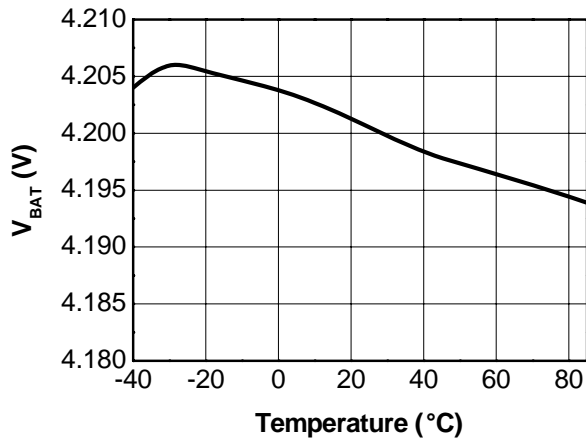

Figure 10. V_{BAT} vs Temperature
 $V_{IN} = 5.0\text{ V}$, $I_{CHG} = 650\text{ mA}$, $I_{BAT} = 100\text{ mA}$

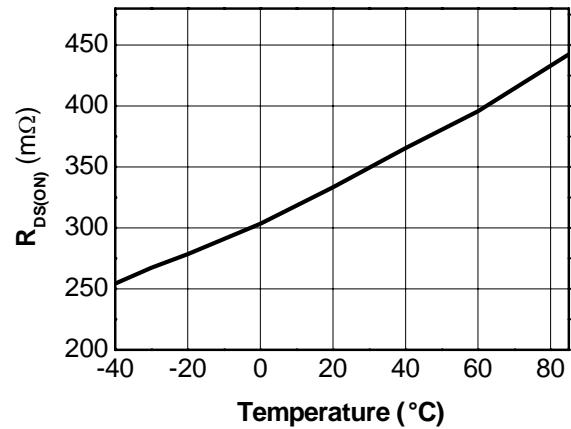

Figure 13. $R_{DS(ON)}$ vs Temperature
 $I_{CHG} = 650\text{ mA}$, $V_{BAT} = 4.0\text{ V}$, $I_{BAT} = 600\text{ mA}$

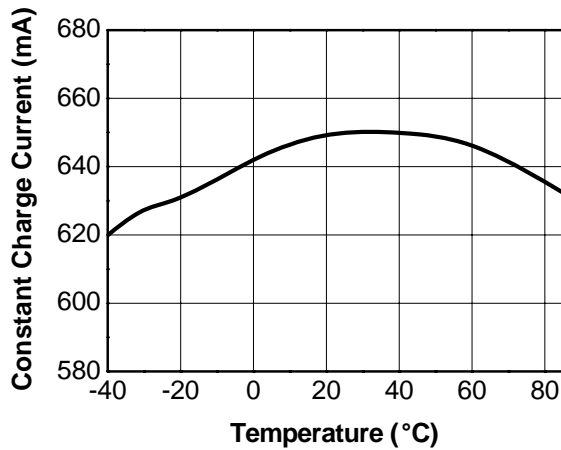

Figure 11. Constant Charge Current vs Temperature
 $I_{CHG} = 650\text{ mA}$, $V_{IN} = 5.0\text{ V}$, $V_{BAT} = 3.9\text{ V}$

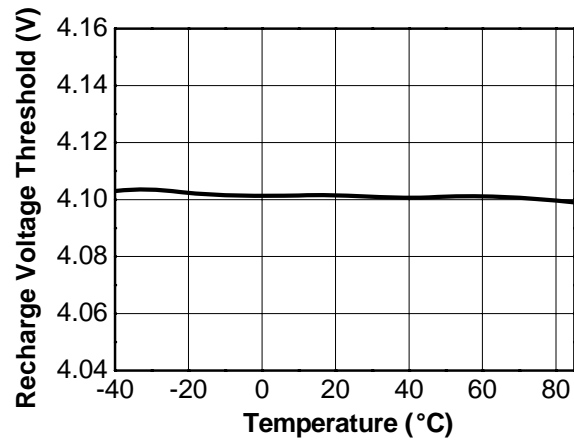

Figure 14. Recharge Voltage Threshold vs Temperature
 $V_{IN} = 5.0\text{ V}$, $I_{CHG} = 650\text{ mA}$

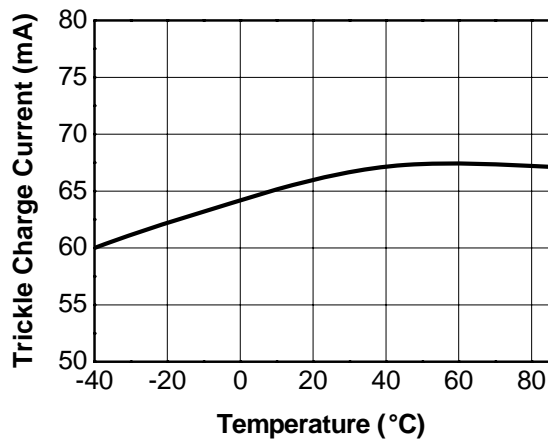

Figure 12. Trickle Charge Current vs Temperature
 $I_{CHG} = 650\text{ mA}$, $V_{IN} = 5.0\text{ V}$, $V_{BAT} = 2\text{ V}$

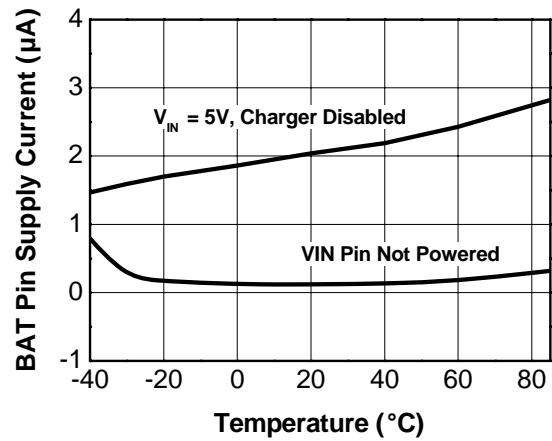

Figure 15. BAT Pin Supply Current vs Temperature
 $I_{CHG} = 650\text{ mA}$, $V_{BAT} = 5.0\text{ V}$

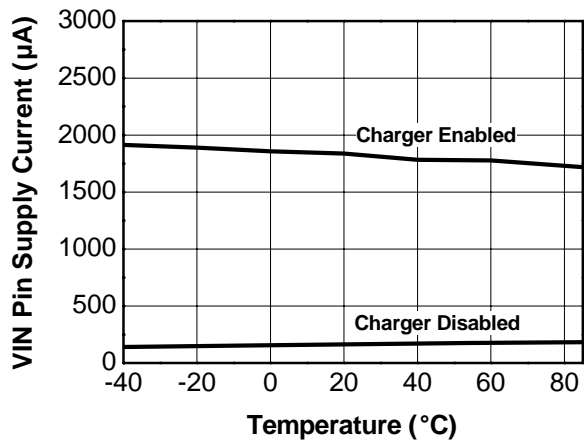

Figure 16. VIN Pin Supply Current vs Temperature
 $I_{CHG} = 650 \text{ mA}$, $V_{BAT} = 5.0 \text{ V}$, $I_{BAT} = 0 \text{ mA}$

FUNCTIONAL DESCRIPTION

INTRODUCTION

The MC34674 is a fully-integrated Li-Ion and Li-Polymer battery charger optimized for travel charger or cradle charger applications. It offers 28 V input-voltage rating for protection against failed AC/DC converters, 0.2% output voltage accuracy at room temperature, and the ability to operate with a current-limited AC/DC output for minimum heat generation.

The MC34674 follows the standard charging profile with trickle, constant-current (CC) and constant-voltage (CV) charge modes, as shown in Figure 17. The trickle-mode current I_{TRKL} is pre-set to 10% of the CC-mode current I_{CHG} when the battery voltage is lower than the trickle-mode threshold V_{TRKL} . In the CC-mode, the output voltage increases until it reaches 4.2 V. Then the charger enters the CV-mode with the output voltage regulated at 4.2 V. The end-of-charge (EOC) current threshold I_{EOC} , which is utilized to indicate the termination of a charge cycle, is preset to 10% of the CC-mode current.

Other features include automatic recharging, internal thermal regulation to prevent overheating the device, an

external NTC interface to prevent charging when the ambient temperature is out of a set window, an internal timer for safety, and smart battery connection verification.

Two indication outputs make it easy to report the input power status and the charge status to users via LEDs.

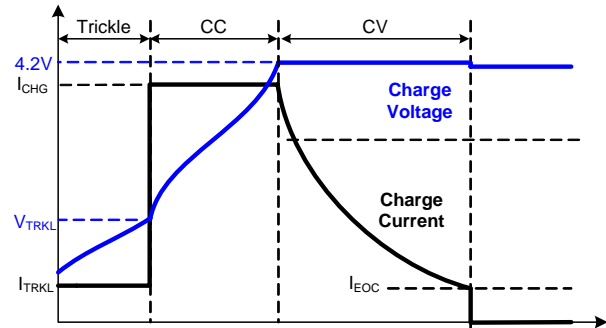

Figure 17. Charge Profile

FUNCTIONAL PIN DESCRIPTION

INPUT SUPPLY VOLTAGE (VIN)

The supply input. This pin should be bypassed to ground with a 1.0 μ F capacitor.

GREEN INDICATOR ($\overline{\text{GRN}}$)

Open-drain logic output to indicate the charging status. This pin drives the green-color LED in a dual-color LED pack with an internal 6.0 mA current source.

RED INDICATOR ($\overline{\text{RED}}$)

Open-drain logic output to indicate the charging status. This pin drives the red-color LED in a dual-color LED pack with an internal 6.0 mA current source.

ENABLE ($\overline{\text{EN}}$)

Active-low enable logic input. This pin is internally pulled to ground by a weak current source. When the pin is left floating, the charger is enabled. Pulling this pin to high voltage externally disables the charger.

GROUND (GND)

Ground.

NTC INTERFACE INPUT (TEMP)

Negative temperature coefficient (NTC) thermistor interface pin. This pin is connected to an NTC thermistor in the battery pack to monitor the battery temperature. A pull-up resistor is required between the TEMP pin and VREF pin.

NTC INTERFACE BIAS VOLTAGE (VREF)

To supply bias voltage for the NTC interface circuit.

CHARGER OUTPUT (BAT)

Charger output pin. Connect this pin to the battery. This pin should be bypassed to ground with a 1.0 μ F or higher capacitor.

EXPOSED PAD (EPAD)

Exposed pad. The pad must be soldered on the large ground plane on the PCB to enhance the thermal conductivity. The pad must be connected to GND electrically.

FUNCTIONAL INTERNAL BLOCK DESCRIPTION

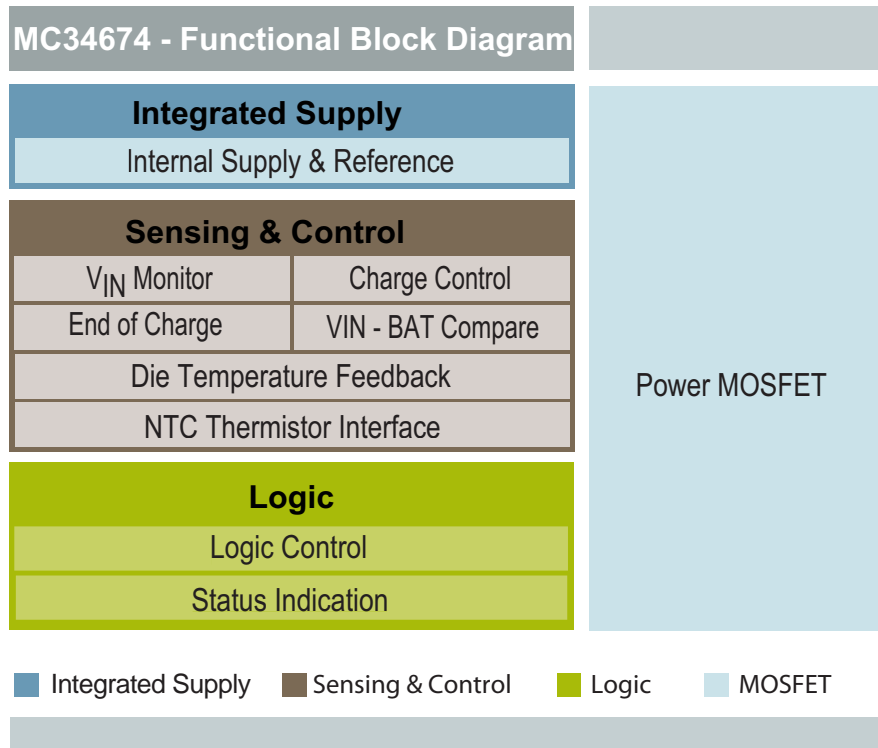

Figure 18. 34674 Functional Internal Block Diagram

INTEGRATED SUPPLY

INTERNAL SUPPLY AND REFERENCE

The internal supply and reference block steps down the high input voltage to a lower voltage to power all the internal control blocks. In addition, this block generates the reference voltages for other functional blocks.

SENSING AND CONTROL

VIN MONITOR

The VIN monitor block monitors the input voltage for two thresholds, power-on-reset (POR) and over-voltage protection (OVP). If the input is lower than the POR or higher than the OVP threshold, this block outputs a logic signal to disable the charger.

CHARGE CONTROL

The charge-control block controls the gate voltage of the power MOSFET to regulate the charge current, the battery voltage, or the die temperature. It can also completely turn off the power MOSFET to stop the current flow between the input and the battery.

EOC (END OF CHARGE)

The EOC block monitors the charge current and the battery voltage for the EOC conditions. Once the EOC

conditions are reached, this block outputs a logic signal to indicate the end of the charge.

VIN-BAT COMPARATOR

The VIN-BAT comparator monitors the voltage difference between the input voltage V_{IN} and the battery voltage V_{BAT} , as shown in [Figure 2](#). The input voltage has to be higher than the battery voltage for the charger to be enabled. If the input voltage falls below the battery voltage, this block outputs a signal to disable the charger to prevent the leakage current from the battery to the input. Due to the intrinsic input offset voltage of the VIN-BAT comparator, a small voltage, V_{OS} , is added. The added V_{OS} guarantees that the power MOSFET is turned off when the input voltage is lower than the battery voltage.

DIE TEMPERATURE FEEDBACK

The die temperature feedback block monitors the die temperature. Once the die temperature reaches a threshold of 110°C, the charge-control block can reduce the charge current to prevent further temperature rise.

NTC INTERFACE

The NTC interface block offers an interface to an external NTC thermistor circuit to monitor the battery temperature and to set the charge temperature window.

LOGIC

LOGIC CONTROL AND STATUS INDICATION

The logic control block determines the on and off states of the charger. It takes the signals from the VIN Monitor, VIN-BAT comparator, EOC, NTC interface blocks, and the external enable signal EN, and determines the on and off

states as well as the charge status indication outputs of the charger. This block also contains the logic circuit for the battery connection verification and the internal timer.

POWER MOSFET

The power MOSFET passes the charging current from the input to the output.

FUNCTIONAL DEVICE OPERATION

OPERATIONAL MODES

The MC34674 moves through various charge states after being powered, as shown in [Figure 23](#). The following describes each state in detail.

POWER-ON RESET (POR)

When the input voltage rises above the rising power-on-reset (POR) threshold, the charger resets the internal timer, preparing for the start of a charging cycle. The falling edge of the POR threshold is less than 2.6 V, making the MC34674 ideal for working with a current-limited AC/DC converter.

POWER-PRESENCE VERIFICATION

After the POR, the MC34674 indicates the power presence to the users via a dual-color LED driven by the $\overline{\text{GRN}}$ and $\overline{\text{RED}}$ pins. The indication is a sequence of four colors using the dual-color LED in the sequence of red, green, yellow (by turning on both colors) and OFF (by turning off both colors). Each color is on for 0.5 seconds.

ENABLE/DISABLE VERIFICATION

The charger then tries to validate the logic level of the $\overline{\text{EN}}$ input. The $\overline{\text{EN}}$ input is an active-low input with a weak internal pull-down circuit. Leaving the $\overline{\text{EN}}$ pin floating is equivalent to a low input. If the $\overline{\text{EN}}$ stays at the low state for more than 100ms, the charger is enabled. This 100ms filter applies to both the rising and the falling edges of the $\overline{\text{EN}}$ input to prevent mis-triggering of the $\overline{\text{EN}}$ signal by any transient event such as an ESD event. The $\overline{\text{EN}}$ input has to stay in a new state continuously for more than 100ms for the new state to be recognized.

The VIN-BAT comparator output is also a condition for enabling the charger. When the input voltage V_{IN} is lower than the BAT pin voltage V_{BAT} by the V_{OS} , the charger is disabled and stays in the Enable Verification state.

BATTERY CONNECTION VERIFICATION

Once enabled, the charger starts to verify if a battery is connected. The battery connection verification takes 0.5 seconds, during which the dual-color LED and the charger are off. If a battery is found, the charger starts to enter the trickle-charge mode; otherwise, it turns on the yellow color LED for 1 second, then turns off the LED for 0.5 seconds, and then tries to verify the connection again. The verification flow creates an equivalent 0.5 Hz yellow blinking LED indication if there is no battery connected. Once a battery is inserted, the charger will detect it and enter the trickle-charge mode.

TRICKLE-CHARGE MODE

The charger always starts charging with the trickle-charge mode. The trickle-charge mode current is set to 10% of the constant-current (CC) charge mode current that is described next. In trickle-charge mode the charger is on and the LED indicates the red color. When entering the trickle-charge

mode, an internal timer is reset to start counting the total trickle-charge time. In the meantime, the charger begins to measure the battery voltage. If the battery voltage rises above the trickle-charge threshold before the timer finishes, the charge cycle will enter the fast-charge mode that is described next. If the timer expires before the voltage reaching the trickle-charge threshold, the battery is determined to be a faulty battery and a TIMEOUT fault indication is issued. Then the charger turns off and the LED indicates a yellow color.

FAST CHARGE MODE

The fast charge contains two modes, the constant-current (CC)-mode and the constant-voltage (CV)-mode. As shown in [Figure 17](#), the charge current is regulated at a constant value in the CC-mode and the charger output voltage is regulated at a constant 4.2 V in the CV-mode. The charge current can be reduced by the die temperature regulation loop when the die temperature reached 110°C. The CC-mode current is set internally by Freescale. Available values are given in [Table 6](#). Consult Freescale for values that are not listed in [Table 1](#).

Table 6. Customer Selectable CC-Mode Current Values.

No.	I _{CHG} (mA)	No.	I _{CHG} (mA)
1	50	9	450
2	100	10	500
3	150	11	550
4	200	12	650
5	250	13	750
6	300	14	850
7	350	15	950
8	400	16	1050

When entering the fast charge mode, the internal timer is reset again to limit the total fast charge time. The time limit for the fast charge mode is 8 times of that of the trickle-charge mode. When the charge completion conditions are detected or when the total charge time limit is reached, the charger enters the charge completion state.

The LED indicates the red color in the fast charge mode.

CHARGE COMPLETION

The criterion for the charge completion is for the charge current to drop below the end-of-charge (EOC) threshold in the CV-mode. The EOC threshold is set to 10% of the CC-mode current. To ensure that no transient current will mis-trigger the EOC indication, two additional criteria are required to be met. The first one is, the battery voltage needs to be above the recharge threshold. The second is, the charge

current needs to stay below the EOC threshold for more than 0.5 seconds. The charger is turned off and the LED indication is green when charge completes.

If the total fast charge time limit is exceeded, the charger also enters the charge completion state.

RECHARGE MODE

If the battery voltage drops below the recharge threshold after charge completion, the charger will try to recharge the battery to 4.2 V. Because the battery voltage drop can also be caused by the removal of the battery, before starting recharge, the charger tries to verify if the battery is still present. If the battery is not found, then the connection fault is issued again. If the battery is still connected, the charger restarts charging to bring the battery to a full state. The LED indication remains green in this mode.

The recharge mode has the same total charge time limit as the fast charge mode. For any reason the battery voltage falls below the trickle-charge threshold in the recharge mode, the charger will enter the battery connection verification state again, as shown in [Figure 23](#).

TEMPERATURE AND OVER-VOLTAGE FAULT

The NTC interface block offers an interface to an external NTC thermistor circuit to monitor the battery temperature. When the battery temperature is out of a user-programmable window, the charger is disabled and a fault condition is issued with a yellow LED indication. When the fault conditions are removed, the charger enters the battery connection verification state. More detailed description on the NTC interface is offered later in this datasheet.

The charger has an 11 V (typ.) input OVP threshold. When the input voltage is higher than this threshold, the charging is stopped and a fault condition is issued with a yellow LED indication. When the input voltage falls below the OVP threshold, the charger restarts charging and resets the internal digital logic control block.

TIMEOUT FAULT

The TIMEOUT fault can only occur when the charger stays in the trickle-charge mode for a period longer than the time limit. The charger is turned off and a yellow LED indication is issued when this fault occurs. The only path to exit this fault is by toggling the EN input or by recycling the power input.

DETAILED FUNCTIONAL DEVICE OPERATION

NTC INTERFACE

The MC34674 offers an interface to an external NTC thermistor to monitor the battery temperature.

The low and high temperature thresholds in the [Table 4](#) allow users to set a temperature window (such as 0°C to 50°C), within which the charging is allowed. If the battery temperature is out of such a window, a temperature fault is issued and the LED indicates a yellow color.

[Figure 19](#) shows the internal equivalent circuit for the NTC interface and the external NTC thermistor circuit. An internal resistor divider that is powered by the VREF pin voltage, V_{VREF} , creates two reference voltages, $1/3 V_{VREF}$ and $2/3 V_{VREF}$. An external resistor divider also powered by V_{VREF} generates the voltage V_{TEMP} to represent the battery temperature. Because the resistance of the NTC thermistor, R_{NTC} , decreases as temperature rises, as shown in [Figure 20](#), V_{TEMP} decreases as the battery temperature increases. Assume T_{COLD} and T_{HOT} are the two temperature thresholds, such as 0°C and 50°C. When the battery temperature falls below T_{COLD} , V_{TEMP} rises above $2/3 V_{VREF}$ and an under-temperature fault is issued. Similarly, when the battery temperature rises above T_{HOT} , V_{TEMP} falls below $1/3 V_{VREF}$, so an over-temperature fault is issued. The relationship between the internal and the external divider voltages at the triggering points can be expressed as the following:

$$\frac{R_{NTC} + R_S}{R_{NTC} + R_S + R_U} = K_X \quad \text{equ. 1}$$

where R_{NTC} is the thermistor resistance at the given temperature, and K_X is the ratio of the internal divider at the given triggering points (see [Table 4](#)). R_U and R_S represent a pull-up resistor and a series resistor in the external resistor divider respectively.

The resistance selection of R_U and R_S can be figured out by the following two equations:

$$\frac{R_{HOT} + R_S}{R_{HOT} + R_S + R_U} = K_{HOT} \quad \text{equ. 2}$$

$$\frac{R_{COLD} + R_S}{R_{COLD} + R_S + R_U} = K_{COLD} \quad \text{equ. 3}$$

where K_{HOT} and K_{COLD} are the resistor divider ratios for the temperature thresholds T_{HOT} and T_{COLD} respectively; R_{HOT} and R_{COLD} are the NTC thermistor resistance at T_{HOT} and T_{COLD} respectively. The typical values for K_{HOT} and K_{COLD} are $1/3$ and $2/3$ respectively, as given in [Table 4](#).

Refer to the Application Information section for more details regarding the R_U and R_S selection.

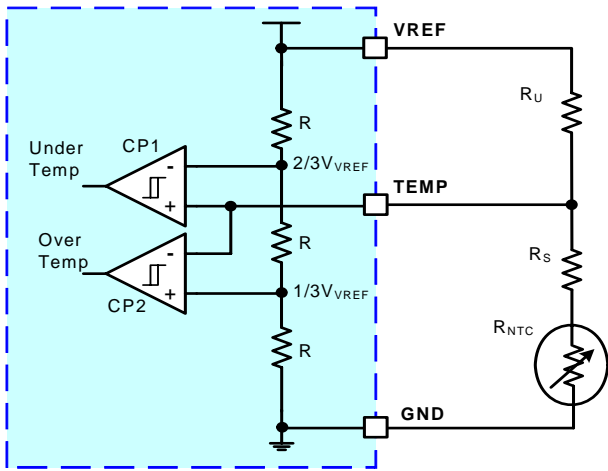

Figure 19. Equivalent Circuit for the NTC Interface

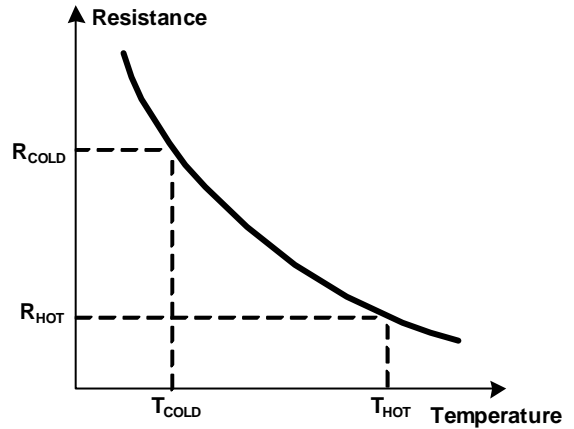

Figure 20. NTC Thermistor Resistance Characteristics

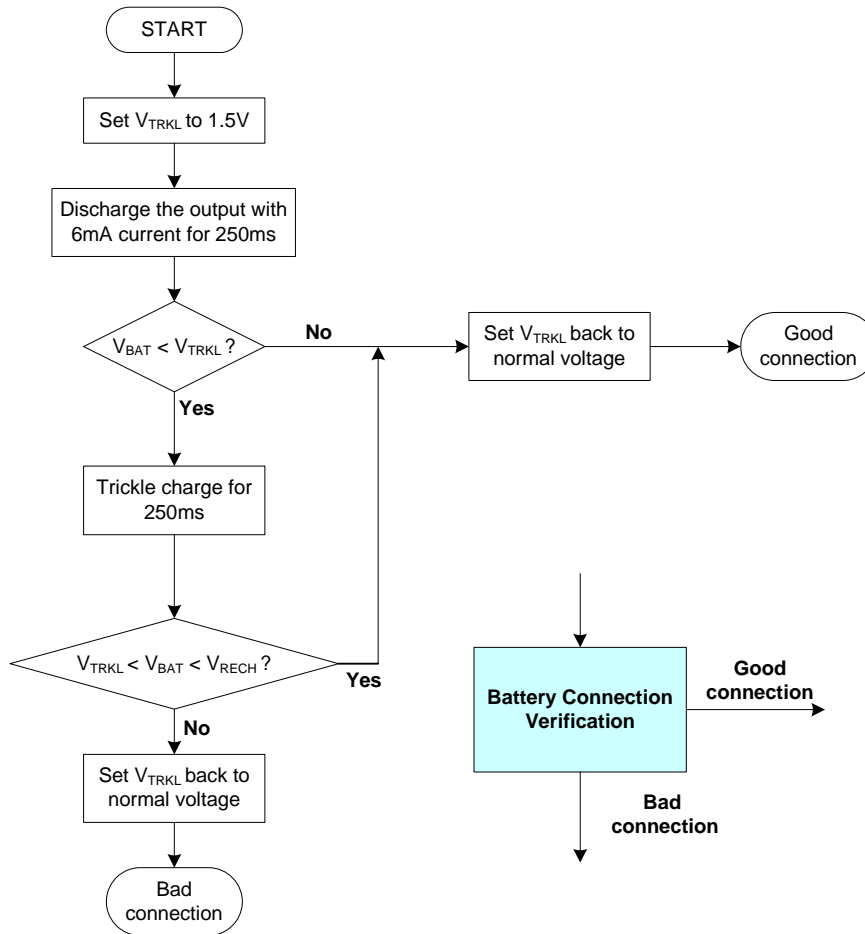

Figure 21. Battery Connection Verification Flow Chart

BATTERY CONNECTION VERIFICATION

Battery connection verification is to ensure that the battery is properly connected before the charging starts. The charger does not start if the battery is short-circuited or open-circuited. A fault indication is issued if the battery is not connected properly. During the connection fault state, the connection verification operates every 2 seconds in order for the charger to recognize a newly inserted battery within 2 seconds.

The verification utilizes the fact that a battery voltage cannot change very fast when being charged or discharged. The charger first discharges the battery with 6mA current for 250 ms. If the battery voltage does not fall below the 1.5 V threshold, then the battery is connected. Otherwise, the charger charges the battery. If the voltage moves above the recharge threshold or stays below 1.5 V within 250 ms, then the battery is not connected properly (either open-circuited or short-circuited). [Figure 21](#) shows the flow chart for the battery connection verification.

The MC34674 has a built-in mechanism to detect if the battery is removed within 1.968 seconds during the charge completion state. [Figure 22](#) shows the simplified analog circuit for this function. In each 1.968 second period, the MC34674 tries to discharge the output with a 585 μA current for 82ms. If during the 82 ms, the output voltage drops below the recharge threshold, the charger will enter the battery connection verification state. Otherwise, the charger remains in the charge completion state. To compensate for the discharge caused by the 585 μA current, the charger outputs a 24 μA current to the output during the whole 1.968 seconds. Both the current and time values for this purpose are well matched, the net output current is guaranteed within $-4.0 \mu\text{A}$ to $+2.0 \mu\text{A}$ to the output.

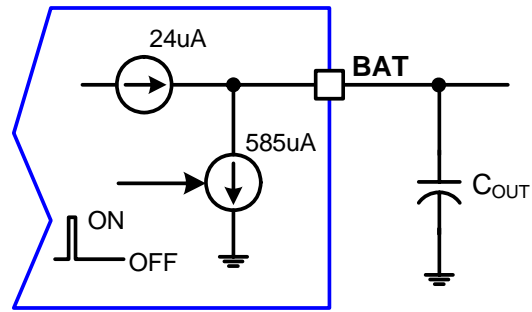

Figure 22. Simplified Battery Removal Detection Circuit.

THERMAL REGULATION

The charger has an internal thermal regulation loop. When the internal temperature reaches 110°C, the charger starts to reduce the charge current to prevent further temperature rise. The current is reduced just enough to maintain the internal temperature at 110°C. The thermal regulation loop removes the concern of thermal failure.

INTERNAL TIMER

An internal timer is offered to set the time reference for the charge time limit. The fast charge time is limited to 4.6 hours (typ.) and the trickle-charge time is limited to 1/8 of the above time.

FLEXIBLE LED INDICATION

The MC34674 has multiple LED indication schemes built in. Consult Freescale for additional indication schemes.

CURRENT-LIMITED AC/DC REGULATOR

The MC34674 has a special low thermal charging operation when powered with a current-limited AC/DC regulator. In the operation, the charge current is limited by the AC/DC regulator and the MC34674 operates as a switch during the CC-mode to minimize the heat generation. Refer to the [Typical Applications](#) section for more details.

STATE DIAGRAMS

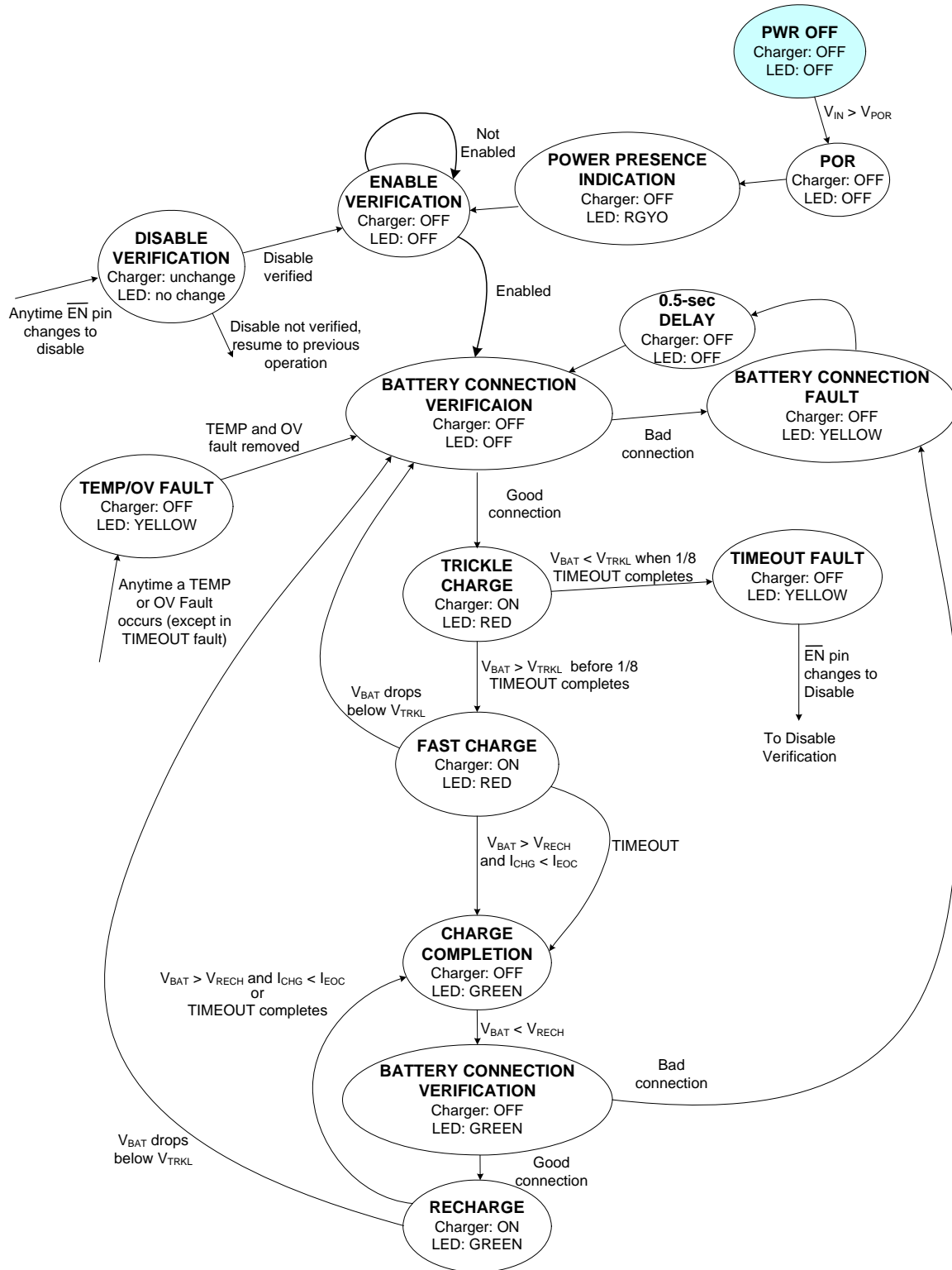

Figure 23. 34674 Flow Chart

TYPICAL APPLICATIONS

INTRODUCTION

The MC34674 can be used as a regular linear charger with the charge current set internally. However, the best way of using this device in the travel charger application is to use this IC together with a current-limited AC/DC regulator. Select a version with the internally set current higher than the target charge current and then power the charger with an AC/DC regulator whose output current is limited to a value lower. This section introduces how to use the MC34674 with a current-limited AC/DC regulator. Also discussed in this section is the application information.

CURRENT-LIMITED AC/DC REGULATOR

A current-limited AC/DC regulator has an output current and voltage characteristics shown in Figure 24. The regulator outputs a no load voltage, V_{NL} , when the supply is not loaded. As the load current increases, the output voltage remains relatively constant. When the load current reaches the current limit of the regulator, I_{LIM} , the regulator output behaves as a constant current source. Usually a current-limited regulator output is specified in a range, as the range limited by the dotted lines.

OPERATION WITH CURRENT-LIMITED AC/DC REGULATOR

The operation of the MC34674 when powered by a current-limited regulator is dependent on the battery voltage. Figure 25 and Figure 26 assist the explanation of the operation.

When the battery voltage is lower than the trickle-charge threshold, the MC34674 is in the trickle mode. The trickle mode current is typically lower than the current limit, I_{LIM} , and hence the AC/DC regulator output is a constant-voltage. The MC34674 operates same as a regular linear charger.

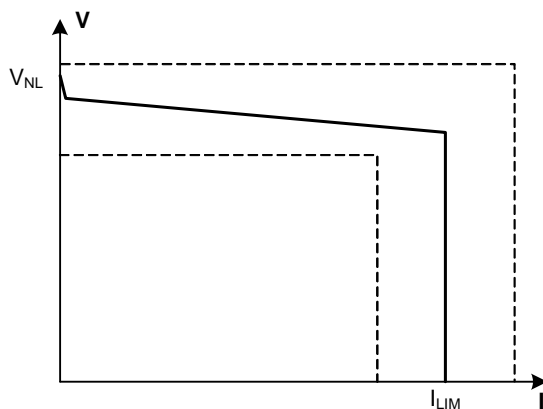

Figure 24. AC/DC Regulator Output I/V Characteristics.

The trickle-charge mode can be illustrated both on the I/V characteristics plot in Figure 25 and the time domain charge curve in Figure 26. In the I/V characteristics trajectory, the battery voltage moves from point a to point b, representing that the current remains at the trickle mode charge current, I_{TRKL} while the battery voltage moves from a value below the trickle-charge threshold, V_{TRKL} , to the trickle-charge threshold. The AC/DC regulator output stays at point A during the trickle mode with no changes for its output current and voltage.

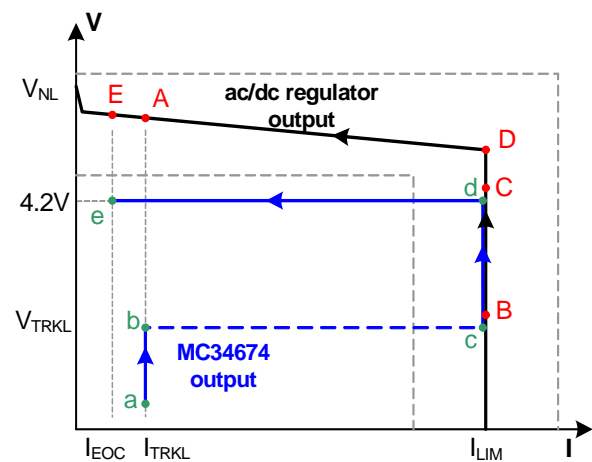

Figure 25. AC/DC Regulator Output and MC34674 Output I/V Characteristics.

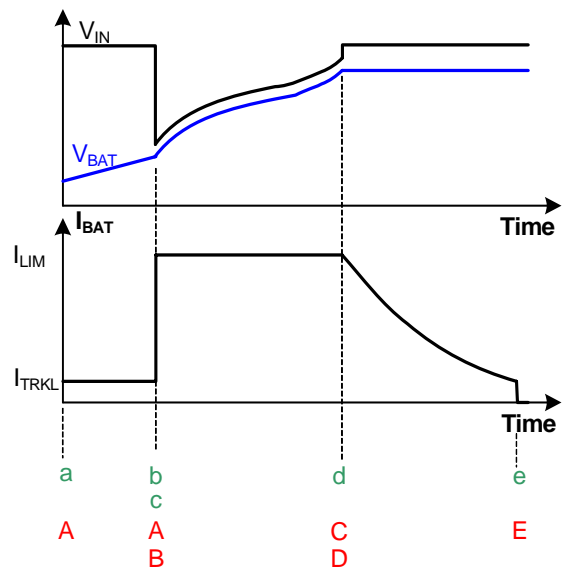

Figure 26. Charging Waveforms When Powered with Current-Limited Regulators.

When the battery voltage rises above the trickle charge threshold, the charger enters the CC-mode. The MC34674 tries to raise the charge current to the internally set reference, such as 1.05 A, by enhancing the power MOSFET. However, since the current provided by the AC/DC regulator is limited and can never reach the set reference, the charger will keep enhancing the MOSFET until it is fully enhanced and is fully turned on. In this mode, the internal power MOSFET behaves as a switch instead of a linearly regulating device. The voltage difference between the input and the output is determined by the on resistance, $R_{DS(ON)}$, of the power MOSFET and the limited output current of the ad/dc regulator.

$$V_{IN} - V_{OUT} = I_{LIM} \times R_{DS(ON)}$$

The power dissipation, P_D , in the MOSFET can be calculated as,

$$P_D = I_{LIM} \times I_{LIM} \times R_{DS(ON)}$$

The charge current in CC-mode is not determined by the MC34674, instead, it is determined by the AC/DC regulator current limit, I_{LIM} , which is a value lower than the charger internally set current reference. The internally set current reference is used as a secondary protection threshold, in case if an AC/DC regulator with a wrong current limit is connected to the input.

The key advantage of using the MC34674 with a current-limited AC/DC regulator is the significant reduction of the power dissipation during the CC-mode. Figure 26 illustrates the small voltage difference between the input and the output of the charger, which is directly proportional to the power dissipation.

When entering the CC-mode, the charger output I/V trajectory jumps from point *b* to *c* and then moves from *c* to *d* as the battery voltage rises to 4.2 V. The AC/DC regulator output trajectory moves from *B* to *C*, as shown in Figure 25.

When the battery voltage reaches the target 4.2V, the charger enters the CV-mode. The charge current starts to decline and the AC/DC regulator output enters its constant-voltage mode. The charger then operates as a regular linear charger again until the charging completes. The battery I/V trajectory moves from *d* to the EOC moment (point *e*) while the AC/DC regulator output trajectory jumps from *C* to *D* and then moves to *E* at the EOC moment.

BALANCING YELLOW COLOR IN LED

The red and the green colors in the LED are driven by two matched 6.0 mA current sources. Such design ensured a consistent brightness of the LED over a large range of the input voltage. When both colors are turned on, the resulting color should be yellow. One can adjust the resulting color by adjusting the brightness of the individual color. A resistor can be added to reduce the brightness of one color, such as the R_1 shown in Figure 27.

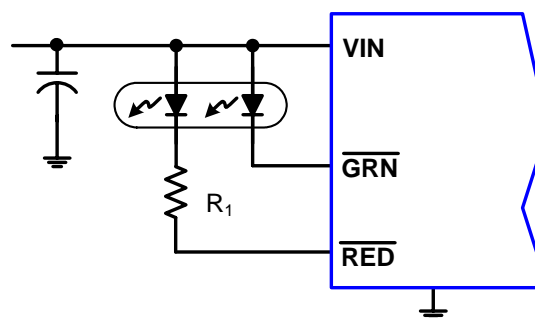

Figure 27. LED Color Balancing Scheme.

INPUT CAPACITOR

The input capacitor is used to reduce the input voltage transient that may cause instability. A 1.0 μ F, X5R, 16 V rated ceramic capacitor is recommended for most applications.

OUTPUT CAPACITOR

For stable operation, an X5R ceramic capacitor with a minimum 1.0 μ F nominal value is recommended at the output. The output capacitance should not be larger than 240 μ F to allow the 585 μ A current to discharge the capacitor voltage to the recharge threshold within 82 ms.

NTC INTERFACE DESIGN

The NTC interface is designed to be able to work with most types of NTC thermistors. This section describes in details how to select the two resistors R_U and R_S shown in Figure 19. In addition, the hysteresis and the tolerance of the temperature thresholds are discussed. The NCP15W104F03RC from Murata is used as an example for the calculations in this section. The partial temperature characteristics of the NCP15W104F03RC are given in Table 7.

Table 7. NTC Thermistor Temperature Characteristics.

Temp (°C)	R-low (k Ω)	R-center (k Ω)	R-high (k Ω)
-2	389.2453	398.6521	408.2455
-1	368.4960	377.1927	386.0560
0	348.9722	357.0117	365.1999
2	313.2543	320.1216	327.1067
3	296.9408	303.2866	309.7370
...			
46	38.4596	39.2132	39.9778
47	36.8626	37.6010	28.3503
50	32.5022	33.1946	33.8983
53	28.7183	29.3660	30.0253
54	27.5694	28.2026	28.8474

R_U and R_S Calculation

The two equations (equ. 2 and equ. 3) on page 16 can be further simplified as the following by substituting the K_{HOT} and K_{COLD} with their typical values:

$$R_S = (R_{COLD} - (4 \times R_{HOT}))/3 \quad \text{equ. 4}$$

$$R_U = 2 \times (R_{COLD} - R_{HOT})/3 \quad \text{equ. 5}$$

The R_S equation requires

$$R_{COLD} \geq 4 \times R_{HOT}$$

otherwise, the R_S calculation results in a negative value.

Assuming the target temperature window is from 0°C to 50°C, from Table 7 it can be found that R_{HOT} = 33.1946 kΩ and R_{COLD} = 357.0117 kΩ. Using equ. 4 and equ. 5, one can find that

$$R_S = 74.74 \text{ k}\Omega$$

$$R_U = 215.9 \text{ k}\Omega$$

Temperature Hysteresis

The thermistor resistance can be found with equ. 1 on page 16, which can be simplified as

$$R_{NTC} = \frac{K_X \cdot (R_S + R_U) - R_S}{1 - K_X} \quad \text{equ. 6}$$

Since the R_S and R_U have already been determined, the thermistor resistance can be found by replacing the K_X with the Low Temperature Falling Threshold and the High Temperature Rising Threshold given in Table 4. The thermistor resistance at these two thresholds can be found as

$$R'_{HOT} = 38.51 \text{ k}\Omega$$

$$R'_{COLD} = 320.6 \text{ k}\Omega$$

From Table 7 it is found that rising threshold for the cold temperature is about 2°C and the falling threshold for the hot temperature is between 46 to 47°C. Therefore the hysteresis for the cold and the hot temperature is 2°C and 2 to 3°C respectively.

Temperature Tolerance

The equ. 6 is also the basis for tolerance calculation. The errors of the internal voltage thresholds, external resistors and the thermistor resistance all contribute to the temperature error. For the low temperature threshold, T_{COLD}, the maximum thermistor resistance happens when the internal threshold is at its maximum, R_U at its maximum and the R_S at its minimum value. Assuming 1% accuracy for both R_U and R_S and taking the maximum value for the low temperature threshold from Table 4, the maximum thermistor resistance at the cold temperature is found to be

$$R_{COLD, MAX} = \quad \text{equ. 7}$$

$$\frac{0.6741 \times (74.74 \times 0.99 + 215.9 \times 1.01) - (74.74 \times 0.99)}{1 - 0.6741}$$

$$= 377.0 \text{ k}\Omega$$

which corresponds to -1.4°C in the R-low column of Table 7.

Similarly, the minimum thermistor resistance at the hot temperature, R_{HOT, MIN}, happens when the internal threshold is at its minimum, R_U at this minimum, and the R_S at its maximum. Using the same method, the R_{HOT, MIN} can be found to be 29.73 kΩ, which corresponds to 53°C approximately.

Based on the above calculation, the tolerances for the cold and the hot temperatures are about 1.4°C and 3°C respectively.

ESD ENHANCEMENT

All pins in the MC34674 are rated 2.0 kV for the ESD performance with the Human Body Model (HBM). The end product usually requires higher ESP performance for the nodes that can be touched by human hands in normal usage of the end product. Three additional capacitors can be used to pass the ESD tests. Figure 28 shows how the three capacitors (C₃, C₄, and C₅) are connected in the circuit.

APPLICATIONS

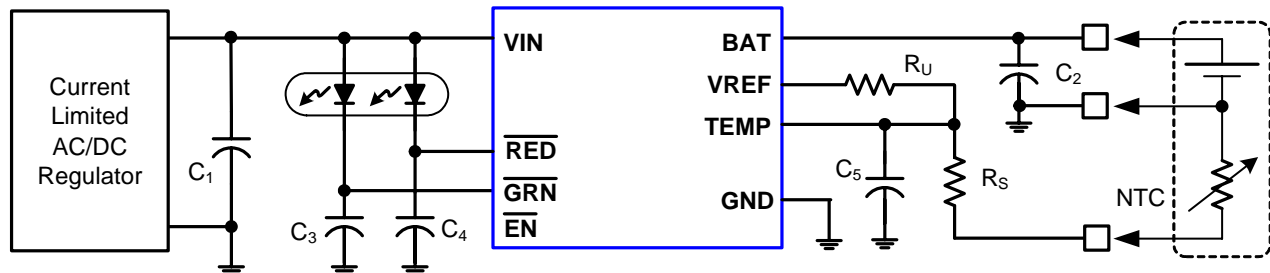

Figure 28. 34674 Typical Application Circuit

C1 and C2 are for decoupling purposes. C3, C4 and C5 are to enhance the ESD performance of the travel charger or

the cradle charger. C1 = 1.0 μF/16 V/X5R, C2 = 1.0 μF/6.3 V/X5R, C3 = C4 = 0.1 μF/16 V/X5R, C5 = 0.1 μF/6.3 V/X5R.

PACKAGING

PACKAGING DIMENSIONS

For the most current package revision, visit www.freescale.com and perform a keyword search using the "98A" listed below.

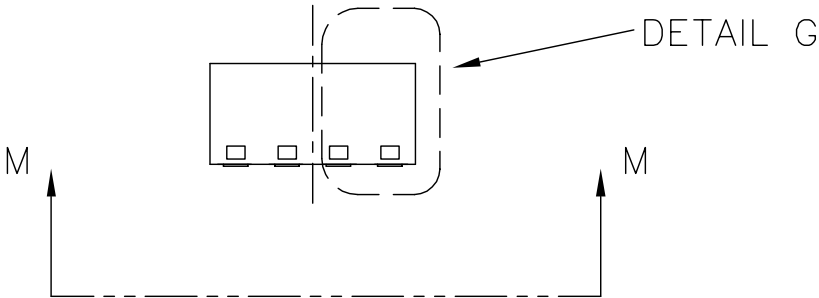
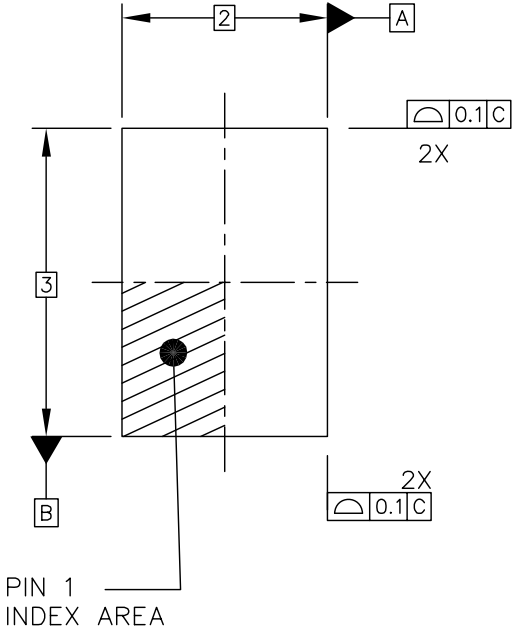

© FREESCALE SEMICONDUCTOR, INC. ALL RIGHTS RESERVED.	MECHANICAL OUTLINE	PRINT VERSION NOT TO SCALE	
TITLE: THERMALLY ENHANCED PLASTIC ULTRA THIN DUAL FLAT NO LEAD PACKAGE (UDFN) 8 TERMINAL, 0.5 PITCH (2 X 3 X 0.65)	DOCUMENT NO: 98ASA10774D	REV: 0	
	CASE NUMBER: 1924-01	14 MAY 2007	
	STANDARD: NON-JEDEC		

EP SUFFIX
8-PIN
98ASA10774D
REVISION 0

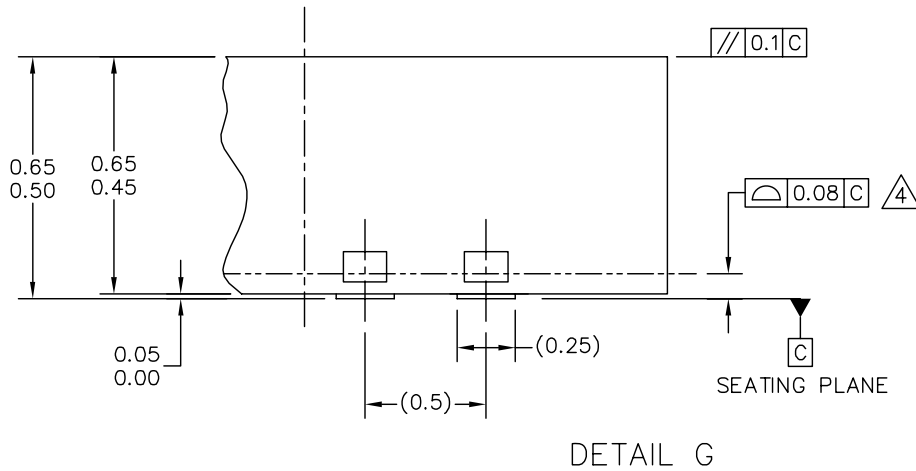
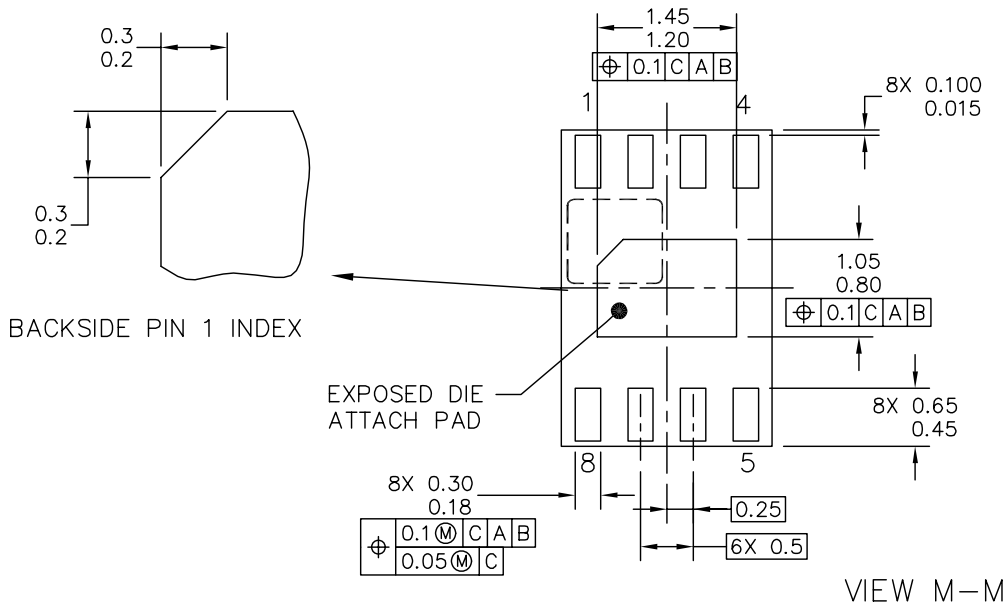

© FREESCALE SEMICONDUCTOR, INC. ALL RIGHTS RESERVED.	MECHANICAL OUTLINE	PRINT VERSION NOT TO SCALE	
TITLE: THERMALLY ENHANCED PLASTIC ULTRA THIN DUAL FLAT NO LEAD PACKAGE (UDFN) 8 TERMINAL, 0.5 PITCH (2 X 3 X 0.65)	DOCUMENT NO: 98ASA10774D	REV: 0	
	CASE NUMBER: 1924-01	14 MAY 2007	
	STANDARD: NON-JEDEC		

EP SUFFIX
8-PIN
98ASA10774D
REVISION 0

REVISION HISTORY

REVISION	DATE	DESCRIPTION OF CHANGES
1.0	1/2007	<ul style="list-style-type: none">Initial Release
2.0	11/2008	<ul style="list-style-type: none">Updated Freescale form and styleAdded Device VariationsMade corrections to coincide with Device Variation table

How to Reach Us:

Home Page:

www.freescale.com

Web Support:

<http://www.freescale.com/support>

USA/Europe or Locations Not Listed:

Freescale Semiconductor, Inc.
Technical Information Center, EL516
2100 East Elliot Road
Tempe, Arizona 85284
+1-800-521-6274 or +1-480-768-2130
www.freescale.com/support

Europe, Middle East, and Africa:

Freescale Halbleiter Deutschland GmbH
Technical Information Center
Schatzbogen 7
81829 Muenchen, Germany
+44 1296 380 456 (English)
+46 8 52200080 (English)
+49 89 92103 559 (German)
+33 1 69 35 48 48 (French)
www.freescale.com/support

Japan:

Freescale Semiconductor Japan Ltd.
Headquarters
ARCO Tower 15F
1-8-1, Shimo-Meguro, Meguro-ku,
Tokyo 153-0064
Japan
0120 191014 or +81 3 5437 9125
support.japan@freescale.com

Asia/Pacific:

Freescale Semiconductor Hong Kong Ltd.
Technical Information Center
2 Dai King Street
Tai Po Industrial Estate
Tai Po, N.T., Hong Kong
+800 2666 8080
support.asia@freescale.com

For Literature Requests Only:

Freescale Semiconductor Literature Distribution Center
P.O. Box 5405
Denver, Colorado 80217
1-800-441-2447 or 303-675-2140
Fax: 303-675-2150
LDCForFreescaleSemiconductor@hibbertgroup.com

Information in this document is provided solely to enable system and software implementers to use Freescale Semiconductor products. There are no express or implied copyright licenses granted hereunder to design or fabricate any integrated circuits or integrated circuits based on the information in this document.

Freescale Semiconductor reserves the right to make changes without further notice to any products herein. Freescale Semiconductor makes no warranty, representation or guarantee regarding the suitability of its products for any particular purpose, nor does Freescale Semiconductor assume any liability arising out of the application or use of any product or circuit, and specifically disclaims any and all liability, including without limitation consequential or incidental damages. "Typical" parameters that may be provided in Freescale Semiconductor data sheets and/or specifications can and do vary in different applications and actual performance may vary over time. All operating parameters, including "Typicals", must be validated for each customer application by customer's technical experts. Freescale Semiconductor does not convey any license under its patent rights nor the rights of others. Freescale Semiconductor products are not designed, intended, or authorized for use as components in systems intended for surgical implant into the body, or other applications intended to support or sustain life, or for any other application in which the failure of the Freescale Semiconductor product could create a situation where personal injury or death may occur. Should Buyer purchase or use Freescale Semiconductor products for any such unintended or unauthorized application, Buyer shall indemnify and hold Freescale Semiconductor and its officers, employees, subsidiaries, affiliates, and distributors harmless against all claims, costs, damages, and expenses, and reasonable attorney fees arising out of, directly or indirectly, any claim of personal injury or death associated with such unintended or unauthorized use, even if such claim alleges that Freescale Semiconductor was negligent regarding the design or manufacture of the part.

Freescale™ and the Freescale logo are trademarks of Freescale Semiconductor, Inc. All other product or service names are the property of their respective owners.

© Freescale Semiconductor, Inc., 2007-8. All rights reserved.