



# Low-Charge Injection, 8-Channel, High-Voltage Analog Switches

## General Description

The MAX4800/MAX4801/MAX4802 provide high-voltage switching on eight channels for ultrasonic imaging and printer applications. The devices utilize BCDMOS process technology to provide eight high-voltage low-charge-injection SPST switches, controlled by a digital interface. Data is clocked into an internal 8-bit shift register and retained by a programmable latch with enable and clear inputs. A power-on reset function ensures that all switches are open on power-up.

The MAX4800/MAX4801/MAX4802 operate with a wide range of high-voltage supplies including:  $V_{PP}/V_{NN} = +100V/-100V$ ,  $+185V/-15V$ , and  $+40V/-160V$ . The digital interface operates from a separate  $V_{DD}$  supply from  $+2.7V$  to  $+13.2V$ . Digital inputs DIN, CLK,  $\overline{LE}$ , and CLR are  $+13.2V$  tolerant, independent of the  $V_{DD}$  supply voltage. The MAX4802 provides integrated  $35k\Omega$  bleed resistors on each switch terminal to discharge capacitive loads.

The MAX4800 and MAX4802 are drop-in replacements for the Supertex HV20220 and HV232. The devices are available in the 48-pin TQFP, 26-bump CSBGA, 28-pin PLCC, and 48-pin TQFN packages. The MAX4801 is a drop-in replacement for the Supertex HV20320 and is available in the 28-pin PLCC package. All devices are specified for the commercial  $0^{\circ}C$  to  $+70^{\circ}C$  temperature range.

## Applications

Ultrasound Imaging  
Printers

## Features

- ◆ Pin-Compatible Replacement for Supertex HV20220 (MAX4800)
- ◆ Pin-Compatible Replacement for Supertex HV20320 (MAX4801)
- ◆ Pin-Compatible Replacement for Supertex HV232 (MAX4802)
- ◆ Flexible High-Voltage Supplies Up to  $V_{PP} - V_{NN} = 200V$
- ◆ Low-Charge Injection, Low-Capacitance  $22\Omega$  Switches
- ◆ DC to 10MHz Analog-Signal Frequency Range
- ◆ -77dB Off Isolation at 5MHz
- ◆ Low  $10\mu A$  Quiescent Current
- ◆ Integrated Bleed Resistors (MAX4802)
- ◆ Available in PLCC, TQFP, TQFN, and CSBGA Packages

MAX4800/MAX4801/MAX4802

## Ordering Information/Selector Guide

PART	BLEED RESISTORS	SECOND SOURCE	PIN-PACKAGE	PACKAGE CODE
MAX4800CCM	No	HV20220FG	48 TQFP	C48-6
MAX4800CQI	No	HV20220PJ	28 PLCC	Q28-4
MAX4800CTM*	No	HV220**	48 TQFN	T4866-1
MAX4800CXZ*	No	HV220**	26 CSBGA	X07265-1
MAX4801CQI*	No	HV20320PJ	28 PLCC	Q28-4
MAX4802CCM	Yes	HV232FG	48 TQFP	C48-6
MAX4802CQI	Yes	HV232PJ	28 PLCC	Q28-4
MAX4802CTM*	Yes	HV230**	48 TQFN	T4866-1
MAX4802CXZ*	Yes	HV230GA	26 CSBGA	X07265-1

**Note:** All devices are specified over the commercial  $0^{\circ}C$  to  $+70^{\circ}C$  temperature range.

\*Future product—contact factory for availability.

\*\*Not pin-for-pin compatible.



Maxim Integrated Products 1

**For pricing, delivery, and ordering information, please contact Maxim/Dallas Direct! at 1-888-629-4642, or visit Maxim's website at [www.maxim-ic.com](http://www.maxim-ic.com).**

# Low-Charge Injection, 8-Channel, High-Voltage Analog Switches

## ABSOLUTE MAXIMUM RATINGS

(All voltages referenced to GND.)

V <sub>DD</sub> Logic-Supply Voltage	.....-0.5V to +15V
V <sub>PP</sub> - V <sub>NN</sub> Supply Voltage	.....220V
V <sub>PP</sub> Positive-Supply Voltage	.....-0.5V to V <sub>NN</sub> + 220V
V <sub>NN</sub> Negative-Supply Voltage	.....+0.5V to -220V
Logic Inputs $\overline{LE}$ , CLR, CLK, DIN	.....-0.5V to +15V
DOUT	.....-0.5V to V <sub>DD</sub> + 0.5V
RGND (MAX4802)	.....-4.5V to +0.5V
COM <sub>-</sub> , NO <sub>-</sub>	.....V <sub>NN</sub> to V <sub>PP</sub>
Continuous Power Dissipation (T <sub>A</sub> = +70°C)	
28-Pin PLCC (derate 10.5mW/°C above +70°C)	.....842mW

48-Pin TQFP (derate 22.7mW/°C above +70°C)	.....1818mW
48-Pin TQFN (derate 27.8mW/°C above +70°C)	.....2222mW
26-Pin CSBGA (derate 11.8mW/°C above +70°C)	.....941mW
Operating Temperature Range	.....0°C to +70°C
Storage Temperature Range	.....-65°C to +150°C
Junction Temperature Range	.....+150°C
Lead Temperature (Soldering, 10s)	.....+300°C
Bump Temperature (Soldering) Lead-Free	.....+260°C
Bump Temperature (Soldering) Lead	.....+245°C

Stresses beyond those listed under "Absolute Maximum Ratings" may cause permanent damage to the device. These are stress ratings only, and functional operation of the device at these or any other conditions beyond those indicated in the operational sections of the specifications is not implied. Exposure to absolute maximum rating conditions for extended periods may affect device reliability.

## ELECTRICAL CHARACTERISTICS

(V<sub>DD</sub> = +2.7V to +13.2V, V<sub>PP</sub> = +40V to V<sub>NN</sub> + 200V, V<sub>NN</sub> = -15V to -160V, T<sub>A</sub> = T<sub>MIN</sub> to T<sub>MAX</sub>, unless otherwise noted. Typical values are at T<sub>A</sub> = +25°C.) (Note 1)

PARAMETER	SYMBOL	CONDITIONS		MIN	TYP	MAX	UNITS
<b>ANALOG SWITCH</b>							
Analog Signal Range	V <sub>COM-</sub> , V <sub>NO-</sub>	(Note 2)		V <sub>NN</sub> + 10		V <sub>PP</sub> - 10	V
Small-Signal Switch On-Resistance	R <sub>ONS</sub>	V <sub>PP</sub> = +40V, V <sub>NN</sub> = -160V, V <sub>COM-</sub> = 0	I <sub>COM</sub> = 5mA	T <sub>A</sub> = 0°C		30	Ω
				T <sub>A</sub> = +25°C	26	38	
				T <sub>A</sub> = +70°C		48	
			I <sub>COM</sub> = 200mA	T <sub>A</sub> = 0°C		25	
				T <sub>A</sub> = +25°C	22	27	
				T <sub>A</sub> = +70°C		32	
		V <sub>PP</sub> = +100V, V <sub>NN</sub> = -100V, V <sub>COM-</sub> = 0	I <sub>COM</sub> = 5mA	T <sub>A</sub> = 0°C		25	
				T <sub>A</sub> = +25°C	22	27	
				T <sub>A</sub> = +70°C		30	
			I <sub>COM</sub> = 200mA	T <sub>A</sub> = 0°C		18	
				T <sub>A</sub> = +25°C	18	24	
				T <sub>A</sub> = +70°C		27	
V <sub>PP</sub> = +160V, V <sub>NN</sub> = -40V or V <sub>PP</sub> = +185V, V <sub>NN</sub> = -15V, V <sub>COM-</sub> = 0	I <sub>COM</sub> = 5mA	T <sub>A</sub> = 0°C		23			
		T <sub>A</sub> = +25°C	20	25			
		T <sub>A</sub> = +70°C		30			
	I <sub>COM</sub> = 200mA	T <sub>A</sub> = 0°C		22			
		T <sub>A</sub> = +25°C	16	25			
		T <sub>A</sub> = +70°C		27			
Small-Signal Switch On-Resistance Matching	ΔR <sub>ONS</sub>	V <sub>PP</sub> = +100V, V <sub>NN</sub> = -100V, V <sub>COM-</sub> = 0, I <sub>COM</sub> = 5mA			5	20	%
Large-Signal Switch On-Resistance	R <sub>ONL</sub>	V <sub>COM-</sub> = V <sub>PP</sub> - 10V, I <sub>COM</sub> = 1A			15		Ω
Shunt Resistance	R <sub>INT</sub>	NO <sub>-</sub> or COM <sub>-</sub> to RGND (MAX4802), switch off		30	35	50	kΩ

# Low-Charge Injection, 8-Channel, High-Voltage Analog Switches

MAX4800/MAX4801/MAX4802

## ELECTRICAL CHARACTERISTICS (continued)

( $V_{DD} = +2.7V$  to  $+13.2V$ ,  $V_{PP} = +40V$  to  $V_{NN} + 200V$ ,  $V_{NN} = -15V$  to  $-160V$ ,  $T_A = T_{MIN}$  to  $T_{MAX}$ , unless otherwise noted. Typical values are at  $T_A = +25^\circ C$ .) (Note 1)

PARAMETER	SYMBOL	CONDITIONS	MIN	TYP	MAX	UNITS
Switch-Off Leakage	$I_{COM\_OFF}$ , $I_{NO\_OFF}$	$V_{COM\_}$ , $V_{NO\_} = V_{PP} - 10V$ or unconnected; RGND unconnected (MAX4802)	$T_A = +25^\circ C$	1	4	$\mu A$
			$T_A = T_{MIN}$ to $T_{MAX}$		10	
Switch-Off DC Offset		$R_L = 100k\Omega$ (MAX4800/MAX4801), No load (MAX4802)		100	300	mV
Switch-On DC Offset		$R_L = 100k\Omega$ (MAX4800/MAX4801), No load (MAX4802)		100	500	mV
Switch-Output Peak Current (Note 3)		$I_{COM\_}$ duty cycle $\leq 0.1\%$	$T_A = 0^\circ C$	3		A
			$T_A = +25^\circ C$	2	3	
			$T_A = +70^\circ C$	2		
Switch-Output Isolation Diode Current (Note 3)		300ns pulse width, 2% duty cycle	$V_{PP} - V_{NN} \leq 200V$ $COM\_$ , NO1-NO7	300		mA
			$V_{PP} - V_{NN} \leq 200V$ , NO0	30		
			$V_{PP} - V_{NN} \leq 160V$ $COM\_$ , NO_	750		
<b>SWITCH DYNAMIC CHARACTERISTICS</b>						
Off-Isolation (Note 3)	$V_{ISO}$	$f = 5MHz$ , $R_L = 1k\Omega$ , $C_L = 15pF$	-30	-33		dB
		$f = 5MHz$ , $R_L = 50\Omega$	-58	-77		
Crosstalk (Note 3)	$V_{CT}$	$f = 5MHz$ , $R_L = 50\Omega$	-60	-80		dB
$COM\_$ , $NO\_$ Off-Capacitance (Note 3)	$C_{COM\_}$ (OFF), $C_{NO\_}$ (OFF)	$V_{COM\_} = 0$ , $V_{NO\_} = 0$ , $f = 1MHz$	4	11	18	pF
$COM\_$ On-Capacitance (Note 3)	$C_{COM\_}$ (ON)	$V_{COM\_} = 0$ , $f = 1MHz$	20	36	56	pF
Output-Voltage Spike (Note 3)	$V_{SPK}$	$R_L = 50\Omega$	-150		+150	mV
Charge Injection	Q	$V_{PP} = +40V$ , $V_{NN} = -160V$ , $V_{COM\_} = 0$		820		pC
		$V_{PP} = +100V$ , $V_{NN} = -100V$ , $V_{COM\_} = 0$		600		
		$V_{PP} = +160V$ , $V_{NN} = -40V$ , $V_{COM\_} = 0$		350		
<b>LOGIC LEVELS</b>						
Logic-Input Low Voltage	$V_{IL}$	$V_{DD} \geq +4.5V$			1.5	V
		$V_{DD} < +4.5V$			0.75	
Logic-Input High Voltage	$V_{IH}$	$V_{DD} \geq +4.5V$		$V_{DD} - 1.5$		V
		$V_{DD} < +4.5V$		$V_{DD} - 0.75$		
Logic-Input Capacitance (Note 3)	$C_{IN}$				10	pF
Logic-Input Leakage	$I_{IN}$		-1		+1	$\mu A$
DOUT Low Voltage	$V_{OL}$	$V_{DD} \geq +4.5V$ , $I_{SINK} = 1mA$			0.4	V
		$V_{DD} < +4.5V$ , $I_{SINK} = 0.5mA$			0.4	V

# Low-Charge Injection, 8-Channel, High-Voltage Analog Switches

## ELECTRICAL CHARACTERISTICS (continued)

( $V_{DD} = +2.7V$  to  $+13.2V$ ,  $V_{PP} = +40V$  to  $V_{NN} + 200V$ ,  $V_{NN} = -15V$  to  $-160V$ ,  $T_A = T_{MIN}$  to  $T_{MAX}$ , unless otherwise noted. Typical values are at  $T_A = +25^\circ C$ .) (Note 1)

PARAMETER	SYMBOL	CONDITIONS		MIN	TYP	MAX	UNITS
DOOUT High Voltage	$V_{OH}$	$V_{DD} \geq +4.5V$ , $I_{SOURCE} = 0.5mA$		$V_{DD} - 0.5$			V
		$V_{DD} < +4.5V$ , $I_{SOURCE} = 0.25mA$		$V_{DD} - 0.5$			V
<b>POWER SUPPLIES</b>							
$V_{DD}$ Supply Voltage				2.7		13.2	V
$V_{PP}$ Supply Voltage				40		$V_{NN} + 200$	V
$V_{NN}$ Supply Voltage				-160		-15	V
$V_{DD}$ Supply Quiescent Current	$I_{DDQ}$	$V_{IL} = 0$ , $V_{IH} = V_{DD}$ , $f_{CLK} = 0$				15	$\mu A$
$V_{DD}$ Supply Dynamic Current	$I_{DD}$	$V_{DD} = +5V$ , $V_{IL} = 0$ , $V_{IH} = +5V$ , $f_{CLK} = 5MHz$				4	mA
$V_{PP}$ Supply Quiescent Current	$I_{PPQ}$	All switches remain on or off, $I_{COM}(ON) = 5mA$			10	50	$\mu A$
$V_{PP}$ Supply Dynamic Current	$I_{PP}$	50kHz output switching frequency with no load	$V_{PP} = +40V$ , $V_{NN} = -160V$	$T_A = 0^\circ C$		6.5	mA
				$T_A = +25^\circ C$		6.5	
				$T_A = +70^\circ C$		6.5	
			$V_{PP} = +100V$ , $V_{NN} = -100V$	$T_A = 0^\circ C$		4.0	
				$T_A = +25^\circ C$		4.0	
				$T_A = +70^\circ C$		4.0	
			$V_{PP} = +160V$ , $V_{NN} = -40V$	$T_A = 0^\circ C$		4.0	
				$T_A = +25^\circ C$		4.0	
				$T_A = +70^\circ C$		4.0	
$V_{NN}$ Supply Quiescent Current	$I_{NNQ}$	All switches remain on or off, $I_{COM}(ON) = 5mA$			10	50	$\mu A$
$V_{NN}$ Supply Dynamic Current	$I_{NN}$	50kHz output switching frequency with no load	$V_{PP} = +40V$ , $V_{NN} = -160V$	$T_A = 0^\circ C$		6.5	mA
				$T_A = +25^\circ C$		6.5	
				$T_A = +70^\circ C$		6.5	
			$V_{PP} = +100V$ , $V_{NN} = -100V$	$T_A = 0^\circ C$		4.0	
				$T_A = +25^\circ C$		4.0	
				$T_A = +70^\circ C$		4.0	
			$V_{PP} = +160V$ , $V_{NN} = -40V$	$T_A = 0^\circ C$		4.0	
				$T_A = +25^\circ C$		4.0	
				$T_A = +70^\circ C$		4.0	

# Low-Charge Injection, 8-Channel, High-Voltage Analog Switches

MAX4800/MAX4801/MAX4802

## TIMING CHARACTERISTICS

( $V_{DD} = +2.7V$  to  $+13.2V$ ,  $V_{PP} = +40V$  to  $V_{NN} + 200V$ ,  $V_{NN} = -15V$  to  $-160V$ ,  $T_A = T_{MIN}$  to  $T_{MAX}$ , unless otherwise noted. Typical values are at  $T_A = +25^\circ C$ .) (Note 1)

PARAMETER	SYMBOL	CONDITIONS	MIN	TYP	MAX	UNITS
<b>ANALOG SWITCH</b>						
Turn-On Time	$t_{ON}$	$V_{NO\_} = V_{PP} - 10V$ , $R_L = 10k\Omega$ , $V_{NN} = -40V$ to $-160V$			5	$\mu s$
Turn-Off Time	$t_{OFF}$	$V_{NO\_} = V_{PP} - 10V$ , $R_L = 10k\Omega$ , $V_{NN} = -40V$ to $-160V$			5	$\mu s$
Output Switching Frequency	$f_{SW}$	Duty cycle = 50%			50	kHz
Maximum $V_{COM\_}$ , $V_{NO\_}$ Slew Rate	$dV/dt$	(Note 3)	20			V/ns
<b>LOGIC TIMING</b> (Figure 1)						
CLK Frequency	$f_{CLK}$	Daisy chaining	$V_{DD} \geq +4.5V$		5	MHz
			$V_{DD} \leq +4.5V$		2.5	
		No daisy chaining	$V_{DD} \geq +4.5V$		10	
			$V_{DD} < +4.5V$		4	
DIN to CLK Setup Time	$t_{DS}$	$V_{DD} \geq +4.5V$	15			ns
		$V_{DD} < +4.5V$	40			
DIN to CLK Hold Time	$t_{DH}$	$V_{DD} \geq +4.5V$	35			ns
		$V_{DD} < +4.5V$	60			
CLK to $\overline{LE}$ Setup Time	$t_{CS}$	$V_{DD} \geq +4.5V$	150			ns
		$V_{DD} < +4.5V$	300			
$\overline{LE}$ Low-Pulse Width	$t_{WL}$	$V_{DD} \geq +4.5V$	150			ns
		$V_{DD} < +4.5V$	300			
CLR High-Pulse Width	$t_{WC}$	$V_{DD} \geq +4.5V$	150			ns
		$V_{DD} < +4.5V$	300			
CLK Rise and Fall Times	$t_R, t_F$	$V_{DD} \geq +4.5V$ (Note 3)			1	$\mu s$
		$V_{DD} < +4.5V$ (Note 3)			1	
CLK to DOUT Delay	$t_{DO}$	$V_{DD} = +5V \pm 10\%$ , $C_L \leq 50pF$	$T_A = 0^\circ C$	55	150	ns
			$T_A = +25^\circ C$	60	150	
			$T_A = +70^\circ C$	70	150	
		$V_{DD} = +3V \pm 10\%$ , $C_L \leq 50pF$	$T_A = T_{MIN}$ to $T_{MAX}$	70	280	

**Note 1:** Specifications at  $0^\circ C$  are guaranteed by correlation and design. Electrical parameters are tested at worst case conditions.

**Note 2:** The analog signal input  $V_{COM\_}$  and  $V_{NO\_}$  must satisfy  $V_{NN} \leq (V_{COM\_}, V_{NO\_}) \leq V_{PP}$ , or remain unconnected during power-up and power-down.

**Note 3:** Guaranteed by characterization; not production tested.

# Low-Charge Injection, 8-Channel, High-Voltage Analog Switches

## Typical Operating Characteristics

( $V_{DD} = +5V$ ,  $V_{PP} = +100V$ ,  $V_{NN} = -100V$ ,  $T_A = +25^\circ C$ , unless otherwise noted.)

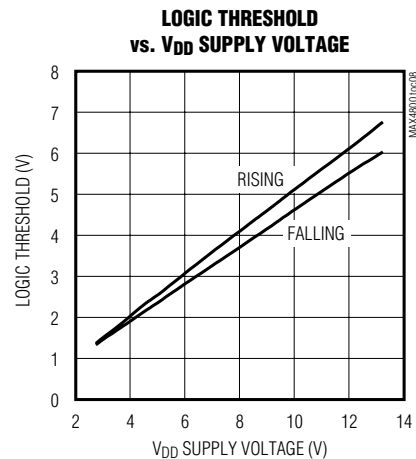
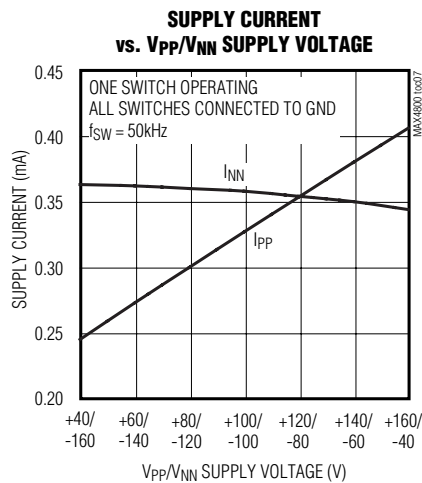
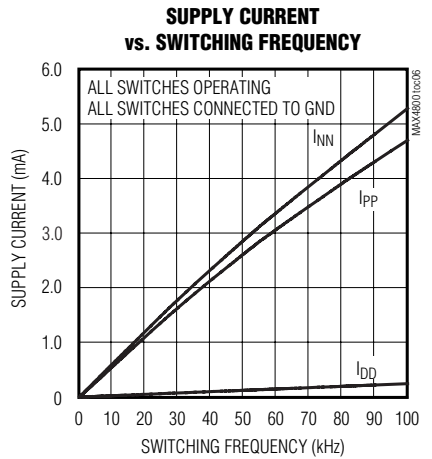
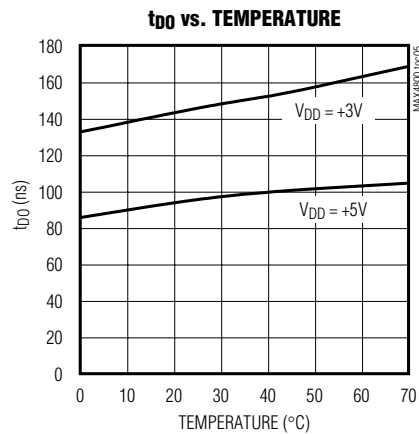
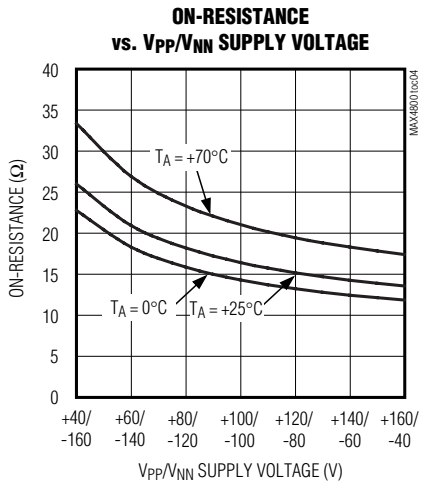
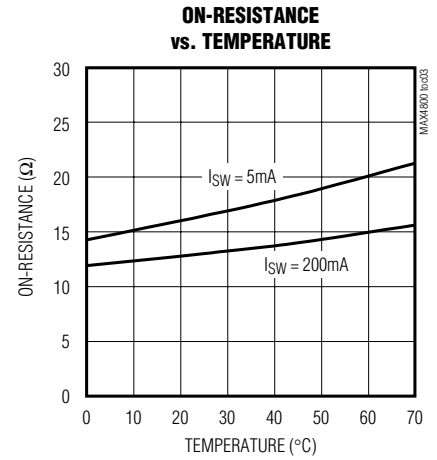
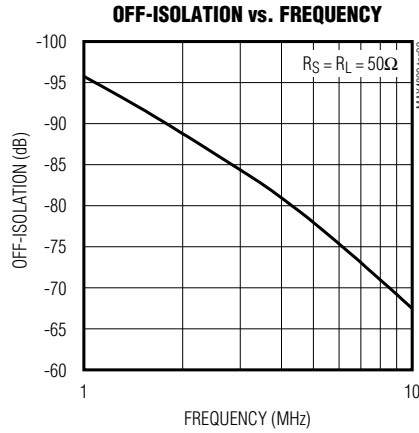
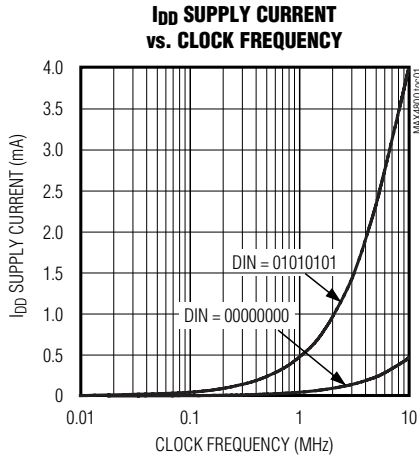

# Low-Charge Injection, 8-Channel, High-Voltage Analog Switches

## Pin Descriptions

MAX4800/MAX4801/MAX4802

PIN					NAME	FUNCTION
MAX4800 TQFP	MAX4800 TQFN	MAX4800 CSBGA	MAX4800 PLCC	MAX4801 PLCC		
1	48	E4	26	26	COM5	Analog Switch 5
2, 4, 6, 7, 9, 11, 13, 15, 17, 19, 21, 23, 26, 27, 30, 31, 32, 38, 40, 42, 44, 46, 48	1, 2, 4, 6, 7, 9, 11, 13, 15, 17, 19, 21, 23, 25, 27, 34, 37, 39, 41, 43, 45, 47	D6	9, 11, 15	11, 14, 15	N.C.	No Connection. Not connected internally.
3	3	E1	27	27	COM4	Analog Switch 4 – Common Terminal
5	5	E3	28	28	NO4	Analog Switch 4 – Normally Open Terminal
8	8	D1	1	1	COM3	Analog Switch 3 – Common Terminal
10	10	D3	2	2	NO3	Analog Switch 3 – Normally Open Terminal
12	12	D4	3	3	COM2	Analog Switch 2 – Common Terminal
14	14	C3	4	4	NO2	Analog Switch 2 – Normally Open Terminal
16	16	C4	5	5	COM1	Analog Switch 1 – Common Terminal
18	18	A4	6	6	NO1	Analog Switch 1 – Normally Open Terminal
20	20	C5	7	7	COM0	Analog Switch 0 – Common Terminal
22	22	D5	8	8	NO0	Analog Switch 0 – Normally Open Terminal
24	24	C6	10	9	V <sub>PP</sub>	Positive High-Voltage Supply. Bypass V <sub>PP</sub> to GND with a 0.1μF or greater ceramic capacitor.
25	26	C7	12	10	V <sub>NN</sub>	Negative High-Voltage Supply. Bypass V <sub>NN</sub> to GND with a 0.1μF or greater ceramic capacitor.
28	29	D7	13	12	GND	Ground
29	30	D9	14	13	V <sub>DD</sub>	Digital-Supply Voltage. Bypass V <sub>DD</sub> to GND with a 0.1μF or greater ceramic capacitor.
33	31	E9	16	16	DIN	Serial Data Input
34	32	E7	17	17	CLK	Serial Clock Input
35	33	E6	18	18	$\overline{LE}$	Latch Enable Input, Active Low
36	35	F7	19	19	CLR	Latch Clear Input
37	36	F6	20	20	DOUT	Serial Data Output
39	38	E5	21	21	COM7	Analog Switch 7 – Common Terminal
41	40	F5	22	22	NO7	Analog Switch 7 – Normally Open Terminal
43	42	F4	23	23	COM6	Analog Switch 6 – Common Terminal
45	44	H4	24	24	NO6	Analog Switch 6 – Normally Open Terminal
47	46	F3	25	25	NO5	Analog Switch 5 – Normally Open Terminal
—	EP	—	—	—	EP	Exposed Paddle. Connect exposed paddle to V <sub>NN</sub> .

# Low-Charge Injection, 8-Channel, High-Voltage Analog Switches

## Pin Descriptions (continued)

MAX4800/MAX4801/MAX4802

PIN				NAME	FUNCTION
MAX4802 TQFP	MAX4802 TQFN	MAX4802 CSBGA	MAX4802 PLCC		
1	48	E4	26	COM5	Analog Switch 5
2, 4, 6, 7, 9, 11, 13, 15, 17, 19, 21, 23, 26, 30, 31, 32, 38, 40, 42, 44, 46, 48	1, 2, 4, 6, 7, 9, 11, 13, 15, 17, 19, 21, 23, 25, 27, 34, 37, 39, 41, 43, 45, 47	—	9, 15	N.C.	Not Connected Internally
3	3	E1	27	COM4	Analog Switch 4 – Common Terminal
5	5	E3	28	NO4	Analog Switch 4 – Normally Open Terminal
8	8	D1	1	COM3	Analog Switch 3 – Common Terminal
10	10	D3	2	NO3	Analog Switch 3 – Normally Open Terminal
12	12	D4	3	COM2	Analog Switch 2 – Common Terminal
14	14	C3	4	NO2	Analog Switch 2 – Normally Open Terminal
16	16	C4	5	COM1	Analog Switch 1 – Common Terminal
18	18	A4	6	NO1	Analog Switch 1 – Normally Open Terminal
20	20	C5	7	COM0	Analog Switch 0 – Common Terminal
22	22	D5	8	NO0	Analog Switch 0 – Normally Open Terminal
24	24	C6	10	V <sub>PP</sub>	Positive High-Voltage Supply. Bypass V <sub>PP</sub> to GND with a 0.1μF or greater ceramic capacitor.
25	26	C7	12	V <sub>NN</sub>	Negative High-Voltage Supply. Bypass V <sub>NN</sub> to GND with a 0.1μF or greater ceramic capacitor.
27	28	D6	11	RGND	Bleed Resistor Ground
28	29	D7	13	GND	Ground
29	30	D9	14	V <sub>DD</sub>	Digital-Supply Voltage. Bypass V <sub>DD</sub> to GND with a 0.1μF or greater ceramic capacitor.
33	31	E9	16	DIN	Serial Data Input
34	32	E7	17	CLK	Serial Clock Input
35	33	E6	18	$\overline{LE}$	Latch Enable Input, Active Low
36	35	F7	19	CLR	Latch Clear Input
37	36	F6	20	DOUT	Serial Data Output
39	38	E5	21	COM7	Analog Switch 7 – Common Terminal
41	40	F5	22	NO7	Analog Switch 7 – Normally Open Terminal
43	42	F4	23	COM6	Analog Switch 6 – Common Terminal
45	44	H4	24	NO6	Analog Switch 6 – Normally Open Terminal
47	46	F3	25	NO5	Analog Switch 5 – Normally Open Terminal
—	EP	—	—	EP	Exposed Paddle. Connect exposed paddle to V <sub>NN</sub> .



# Low-Charge Injection, 8-Channel, High-Voltage Analog Switches

MAX4800/MAX4801/MAX4802

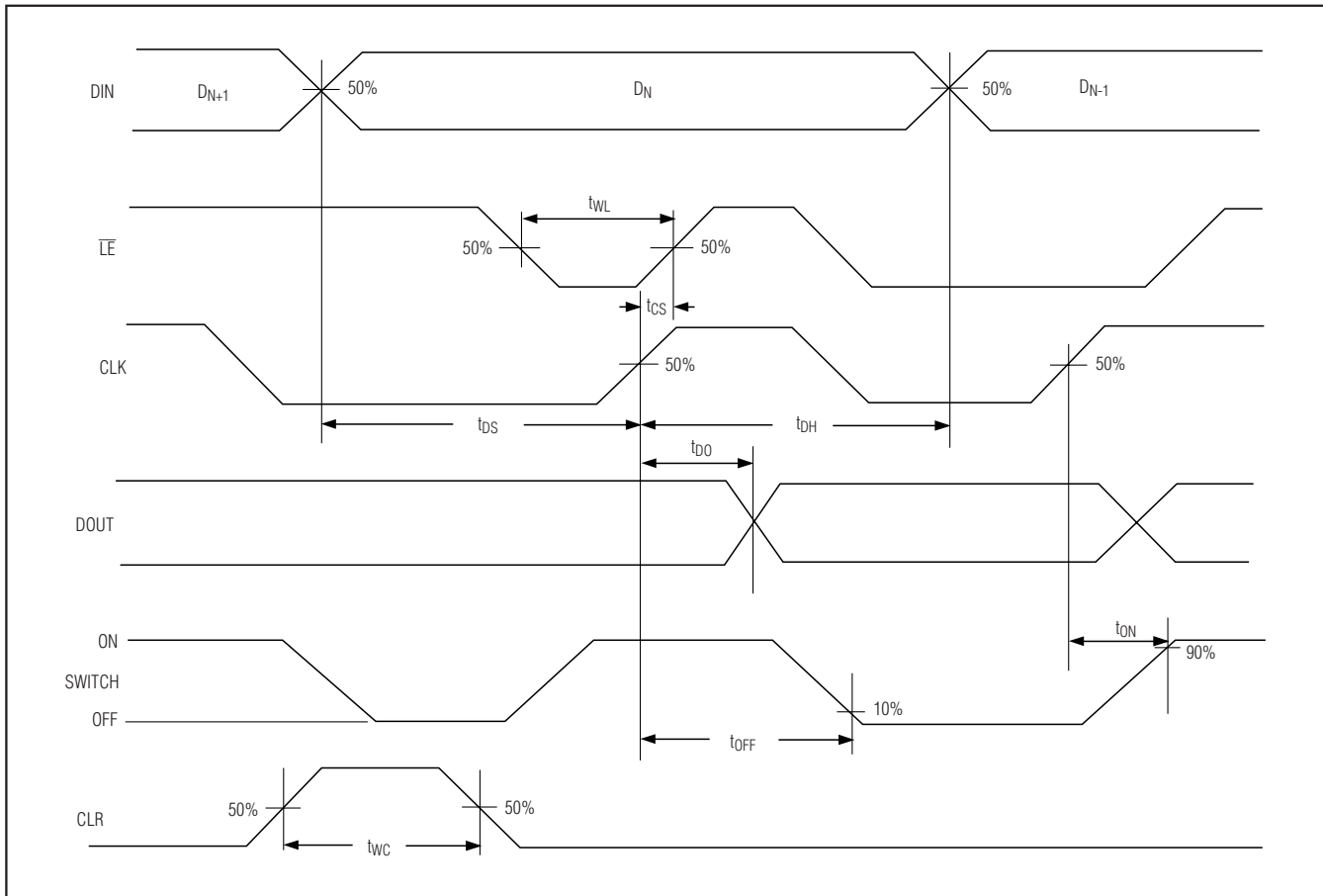

Figure 1. Serial Interface Timing

## Detailed Description

The MAX4800/MAX4801/MAX4802 provide high-voltage switching on eight channels for ultrasound imaging and printer applications. The devices utilize BCDMOS process technology to provide eight high-voltage low-charge-injection SPST switches, controlled by a digital interface. Data is clocked into an internal 8-bit shift register and retained by a programmable latch with enable and clear inputs. A power-on reset function ensures that all switches are open on power-up.

The MAX4800/MAX4801/MAX4802 operate with a wide range of high-voltage supplies including:  $V_{PP}/V_{NN} = +100V/-100V$ ,  $+185V/-15V$ , or  $+40V/-160V$ . The digital interface operates from a separate  $V_{DD}$  supply from  $+2.7V$  to  $+13.2V$ . Digital inputs DIN, CLK,  $\overline{LE}$ , and CLR are  $+13.2V$  tolerant, independent of the  $V_{DD}$  supply voltage. The MAX4802 provides integrated  $35k\Omega$  bleed

resistors on each switch terminal to discharge capacitive loads.

The MAX4800 and MAX4802 are drop-in replacements for the Supertex HV20220 and HV232, respectively. The MAX4801 is a drop-in replacement for the Supertex HV20320.

## Analog Switch

The MAX4800/MAX4801/MAX4802 allow a peak-to-peak analog signal range from  $V_{NN} + 10V$  to  $V_{PP} - 10V$ . Analog switch inputs must be unconnected, or satisfy  $V_{NN} \leq (V_{COM\_}, V_{NO\_}) \leq V_{PP}$  during power-up and power-down.

## High-Voltage Supplies

The MAX4800/MAX4801/MAX4802 allow a wide range of high-voltage supplies. The devices operate with  $V_{NN}$  from  $-160V$  to  $-15V$  and  $V_{PP}$  from  $+40V$  to  $V_{NN} + 200V$ .

## Low-Charge Injection, 8-Channel, High-Voltage Analog Switches

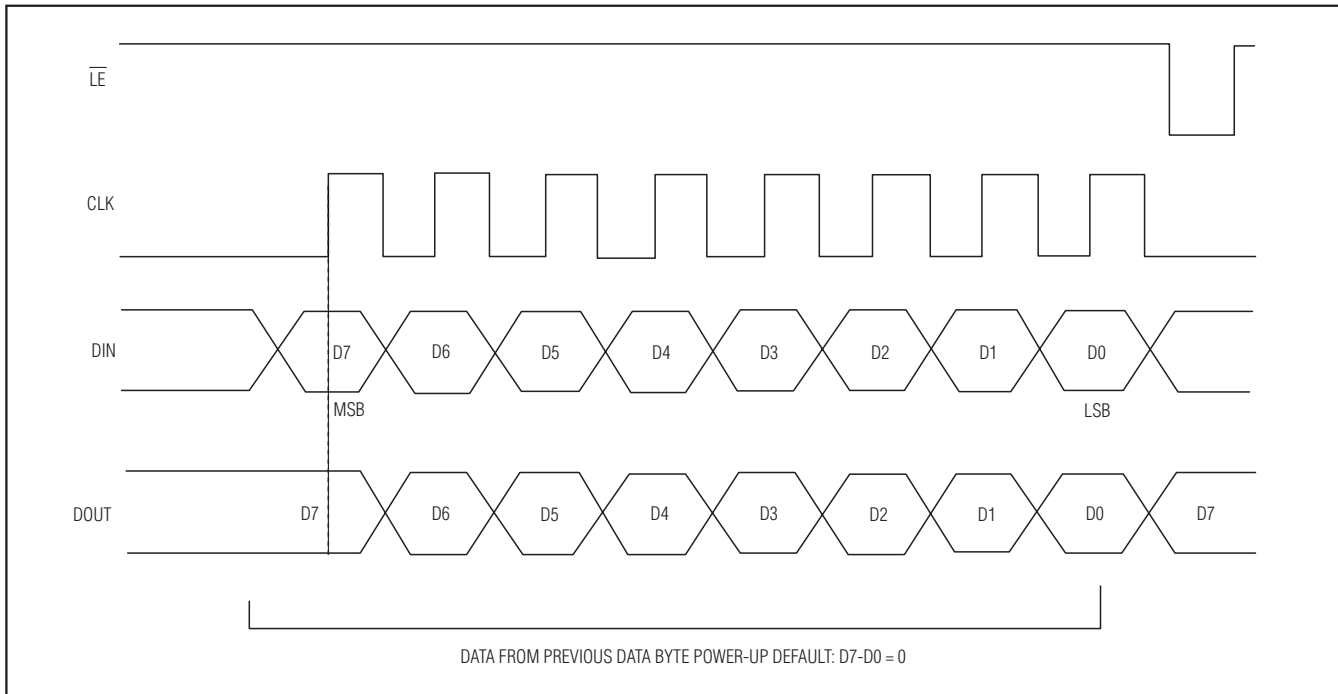

Figure 2. Latch Enable Interface Timing

When  $V_{NN}$  is connected to GND (single-supply applications), the devices operate with  $V_{PP}$  up to +200V. The  $V_{PP}$  and  $V_{NN}$  high-voltage supplies are not required to be symmetrical, but the voltage difference  $V_{PP} - V_{NN}$  must not exceed 200V.

### Bleed Resistors (MAX4802)

The MAX4802 features integrated 35k $\Omega$  bleed resistors to discharge capacitive loads such as piezoelectric transducers. Each analog switch terminal is connected to RGND with a bleed resistor.

### Serial Interface

The MAX4800/MAX4801/MAX4802 are controlled by a serial interface with an 8-bit serial shift register and transparent latch. Each of the eight data bits controls a single analog switch (see Table 1). Data on DIN is clocked with the most significant bit (MSB) first into the shift register on the rising edge of CLK. Data is clocked out of the shift register onto DOUT on the rising edge of CLK. DOUT reflects the status of DIN, delayed by eight clock cycles (see Figures 1 and 2).

### Latch Enable ( $\overline{LE}$ )

Drive  $\overline{LE}$  logic-low to change the contents of the latch and update the state of the high-voltage switches (Figure 2). Drive  $\overline{LE}$  logic-high to freeze the contents of the latch and prevent changes to the switch states. To reduce noise due to clock feedthrough, drive  $\overline{LE}$  logic-high while data is clocked into the shift register. After the data shift register is loaded with valid data, pulse  $\overline{LE}$  logic-low to load the contents of the shift register into the latch.

### Latch Clear (CLR)

The MAX4800/MAX4801/MAX4802 feature a latch clear input. Drive CLR logic-high to reset the contents of the latch to zero and open all switches. CLR does not affect the contents of the data shift register. Pulse  $\overline{LE}$  logic-low to reload the contents of the shift register into the latch.

### Power-On Reset

The MAX4800/MAX4801/MAX4802 feature a power-on reset circuit to ensure all switches are open at power-on. The internal 8-bit serial shift register and latch are set to zero on power-up.

# Low-Charge Injection, 8-Channel, High-Voltage Analog Switches

MAX4800/MAX4801/MAX4802

**Table 1. Serial Interface Programming**

DATA BITS								CONTROL BITS		FUNCTION							
D0 (LSB)	D1	D2	D3	D4	D5	D6	D7 (MSB)	$\overline{LE}$	CLR	SW0	SW1	SW2	SW3	SW4	SW5	SW6	SW7
L								L	L	OFF							
H								L	L	ON							
	L							L	L		OFF						
	H							L	L		ON						
		L						L	L			OFF					
		H						L	L			ON					
			L					L	L				OFF				
			H					L	L				ON				
				L				L	L					OFF			
				H				L	L					ON			
					L			L	L						OFF		
					H			L	L						ON		
						L		L	L								OFF
							H	L	L								ON
X	X	X	X	X	X	X	X	H	L	HOLD PREVIOUS STATE							
X	X	X	X	X	X	X	X	X	H	OFF	OFF	OFF	OFF	OFF	OFF	OFF	OFF

X = Don't Care

## Applications Information

### Logic Levels

The MAX4800/MAX4801/MAX4802 digital interface inputs CLK, DIN,  $\overline{LE}$ , and CLR are tolerant of up to +13.2V, independent of the V<sub>DD</sub> supply voltage, allowing compatibility with higher voltage controllers.

### Daisy Chaining Multiple Devices

Digital output DOUT is provided to allow the connection of multiple MAX4800/MAX4801/MAX4802 devices by daisy chaining (Figure 3). Connect each DOUT to the DIN of the subsequent device in the chain. Connect CLK,  $\overline{LE}$ , and CLR inputs of all devices, and drive  $\overline{LE}$  logic-low to update all devices simultaneously. Drive CLR high to open all the switches simultaneously. Additional shift registers may be included anywhere in series with the MAX4800/MAX4801/MAX4802 data chain.

### Supply Sequencing and Bypassing

The MAX4800/MAX4801/MAX4802 do not require special sequencing of the V<sub>DD</sub>, V<sub>PP</sub>, and V<sub>NN</sub> supply voltages; however, analog switch inputs must be unconnected, or satisfy  $V_{NN} \leq (V_{COM\_}, V_{NO\_}) \leq V_{PP}$  during power-up and power-down. Bypass V<sub>DD</sub>, V<sub>NN</sub>, and V<sub>PP</sub> to GND with a 0.1μF ceramic capacitor as close to the device as possible.

### Exposed Paddle

The MAX4800 and MAX4802 provide an exposed paddle for improved thermal performance in the TQFN package. Connect the exposed paddle to V<sub>NN</sub>.

### Chip Information

PROCESS: BCDMOS

CONNECT EXPOSED PADDLE TO V<sub>NN</sub>

# Low-Charge Injection, 8-Channel, High-Voltage Analog Switches

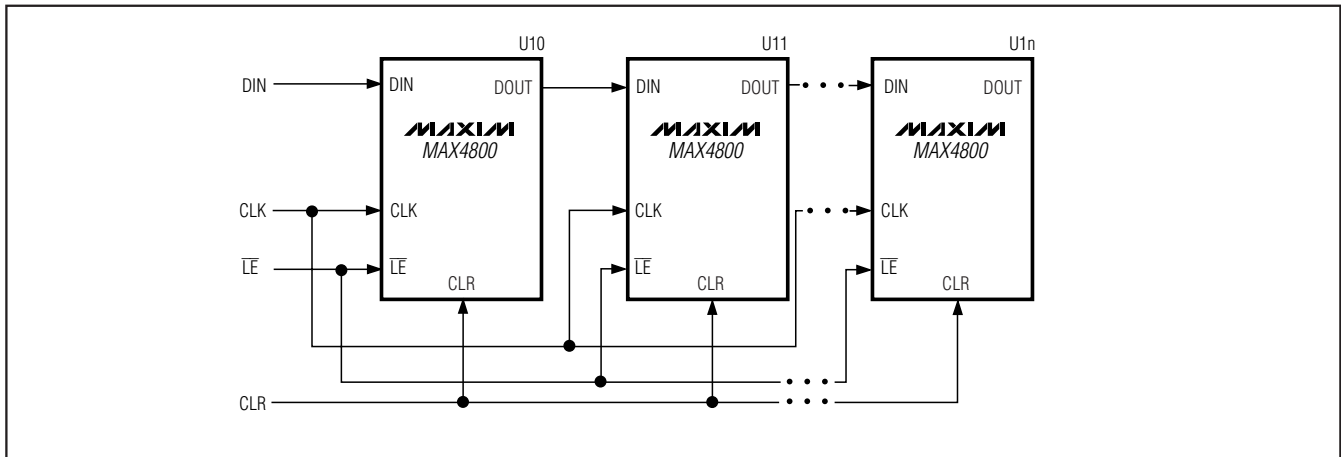
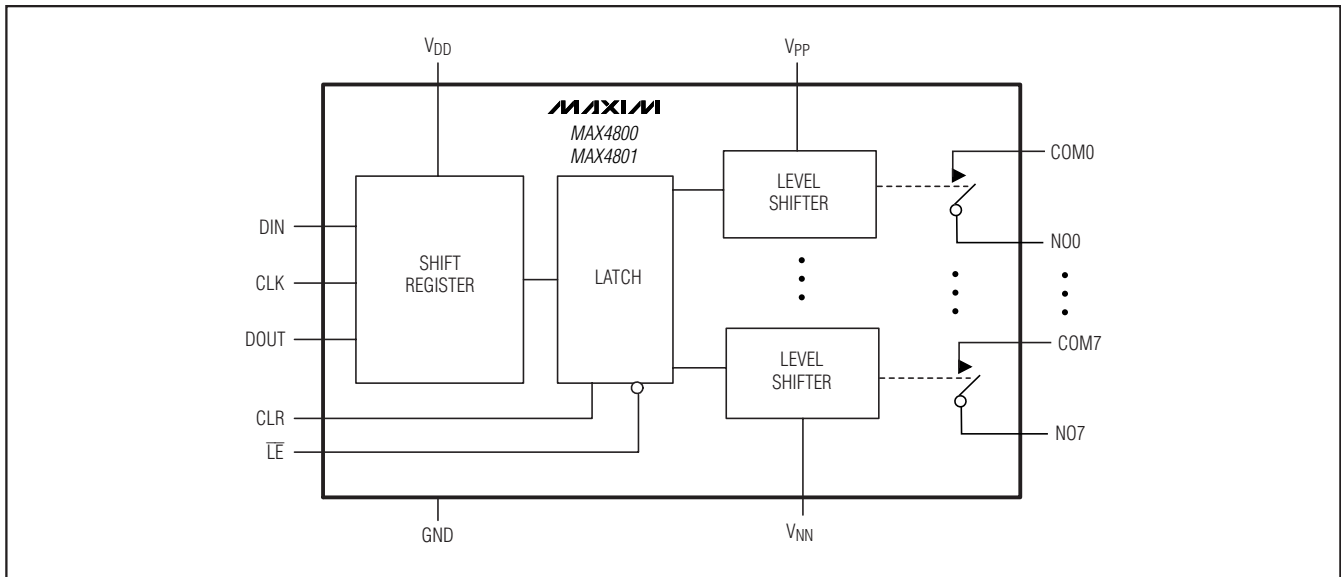

Figure 3. Interfacing Multiple Devices by Daisy-Chaining

## Functional Diagrams



# Low-Charge Injection, 8-Channel, High-Voltage Analog Switches

## Functional Diagrams (continued)

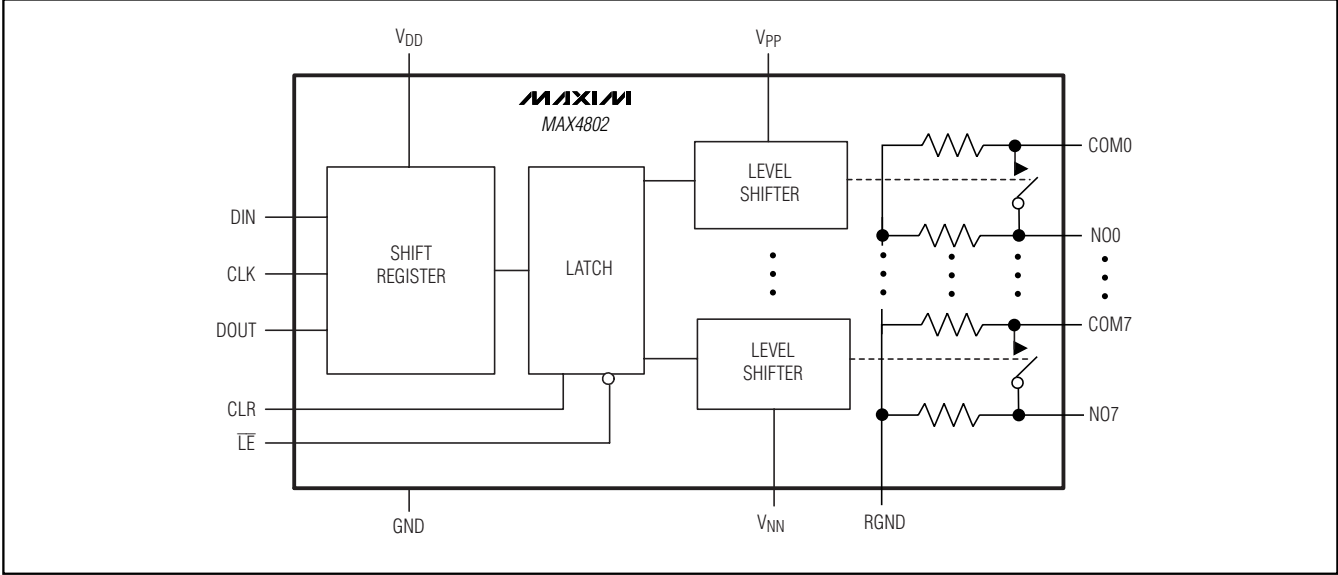

MAX4800/MAX4801/MAX4802

# Low-Charge Injection, 8-Channel, High-Voltage Analog Switches

## Pin Configurations

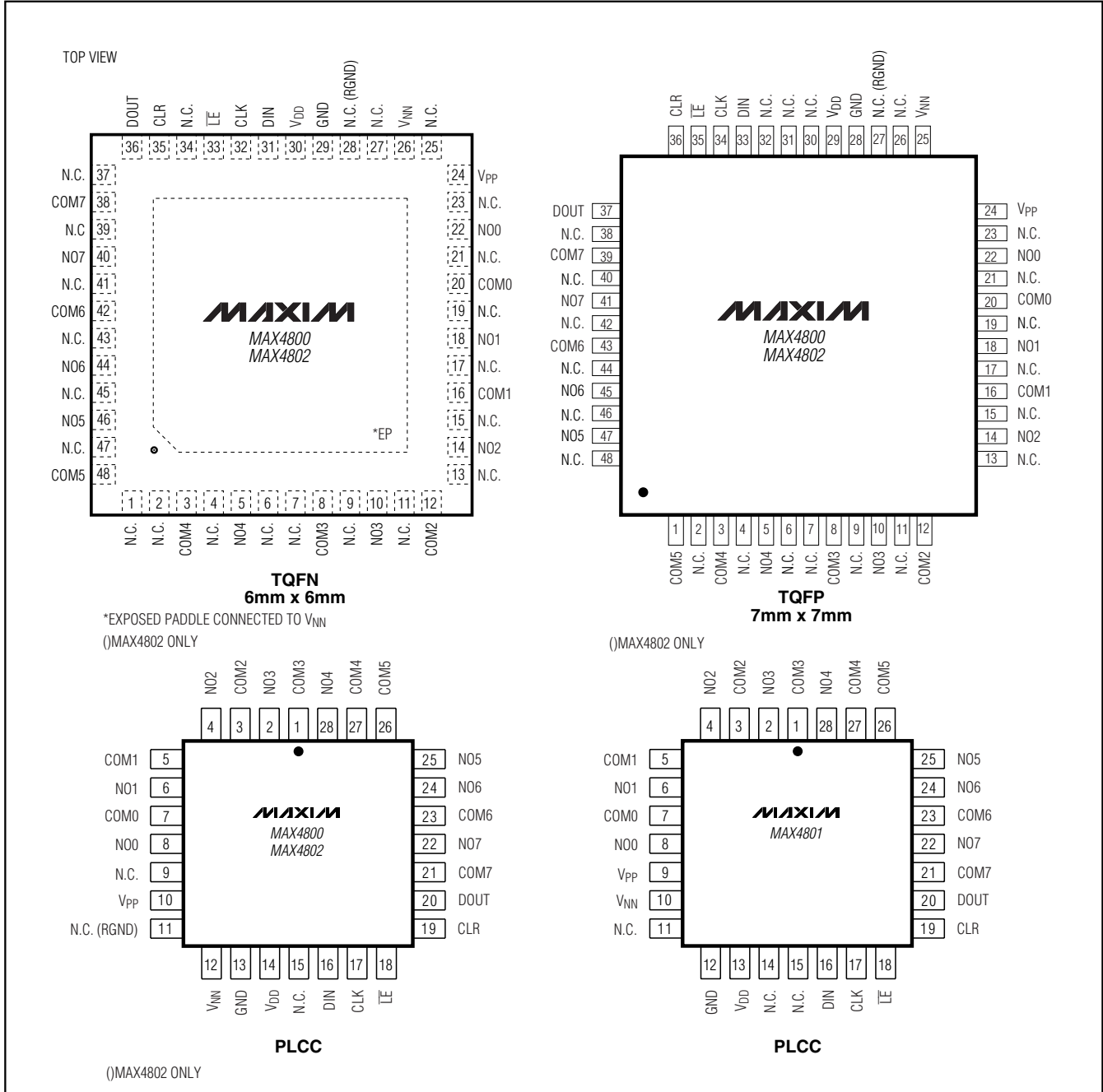

# Low-Charge Injection, 8-Channel, High-Voltage Analog Switches

## Pin Configurations (continued)

**MAX4800/MAX4801/MAX4802**

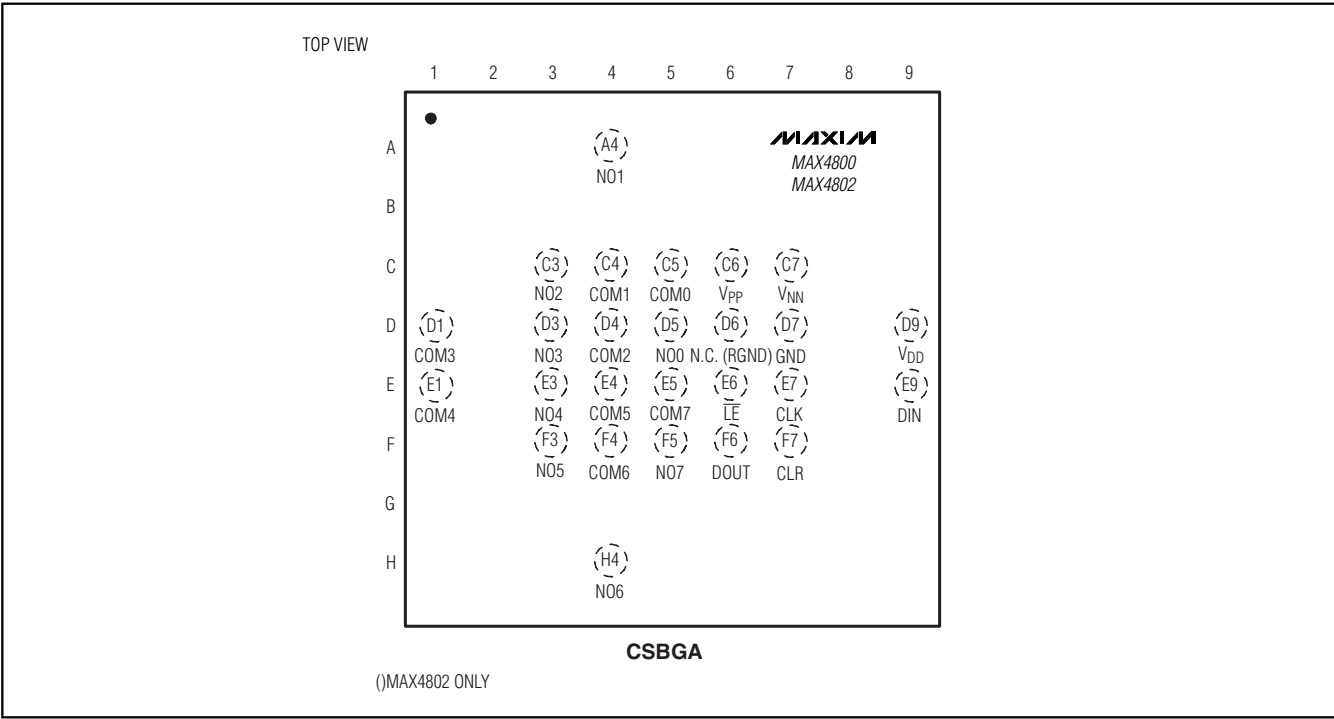

# Low-Charge Injection, 8-Channel, High-Voltage Analog Switches

## Package Information

(The package drawing(s) in this data sheet may not reflect the most current specifications. For the latest package outline information, go to [www.maxim-ic.com/packages](http://www.maxim-ic.com/packages).)

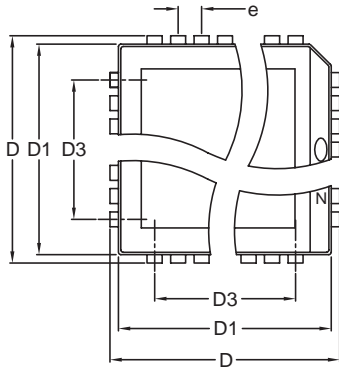

	INCHES		MILLIMETERS	
	MIN	MAX	MIN	MAX
A	0.165	0.180	4.20	4.57
A1	0.090	0.120	2.29	3.04
A2	0.145	0.156	3.69	3.96
A3	0.020	---	0.51	---
B	0.013	0.021	0.33	0.53
B1	0.026	0.032	0.66	0.81
C	0.009	0.011	0.23	0.28
e	0.050		1.27	

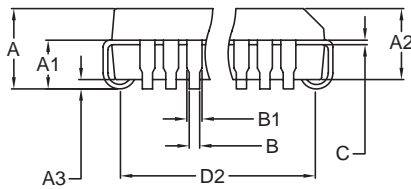

	INCHES		MILLIMETERS		N	MO047
	MIN	MAX	MIN	MAX		
D	0.385	0.395	9.78	10.03	20	AA
D1	0.350	0.356	8.89	9.04		
D2	0.290	0.330	7.37	8.38		
D3	0.200	REF	5.08	REF		

D	0.485	0.495	12.32	12.57	28	AB
D1	0.450	0.456	11.43	11.58		
D2	0.390	0.430	9.91	10.92		
D3	0.300	REF	7.62	REF		

D	0.685	0.695	17.40	17.65	44	AC
D1	0.650	0.656	16.51	16.66		
D2	0.590	0.630	14.99	16.00		
D3	0.500	REF	12.70	REF		

D	0.785	0.795	19.94	20.19	52	AD
D1	0.750	0.756	19.05	19.20		
D2	0.690	0.730	17.53	18.54		
D3	0.600	REF	15.24	REF		

D	0.985	0.995	25.02	25.27	68	AE
D1	0.950	0.958	24.13	24.33		
D2	0.890	0.930	22.61	23.62		
D3	0.800	REF	20.32	REF		

NOTES:

1. D1 DOES NOT INCLUDE MOLD FLASH.
2. MOLD FLASH OR PROTRUSIONS NOT TO EXCEED .20mm (.008") PER SIDE.
3. LEADS TO BE COPLANAR WITHIN .10mm.
4. CONTROLLING DIMENSION: MILLIMETER
5. MEETS JEDEC MO047-XX AS SHOWN IN TABLE.
6. N = NUMBER OF PINS.

<small>PROPRIETARY INFORMATION</small>	
TITLE: FAMILY PACKAGE OUTLINE: 20L, 28L, 44L, 52L, 68L PLCC	
APPROVAL	DOCUMENT CONTROL NO. 21-0049
REV. D	1/1

PLCC.EPS



# Low-Charge Injection, 8-Channel, High-Voltage Analog Switches

## Package Information (continued)

(The package drawing(s) in this data sheet may not reflect the most current specifications. For the latest package outline information, go to [www.maxim-ic.com/packages](http://www.maxim-ic.com/packages).)

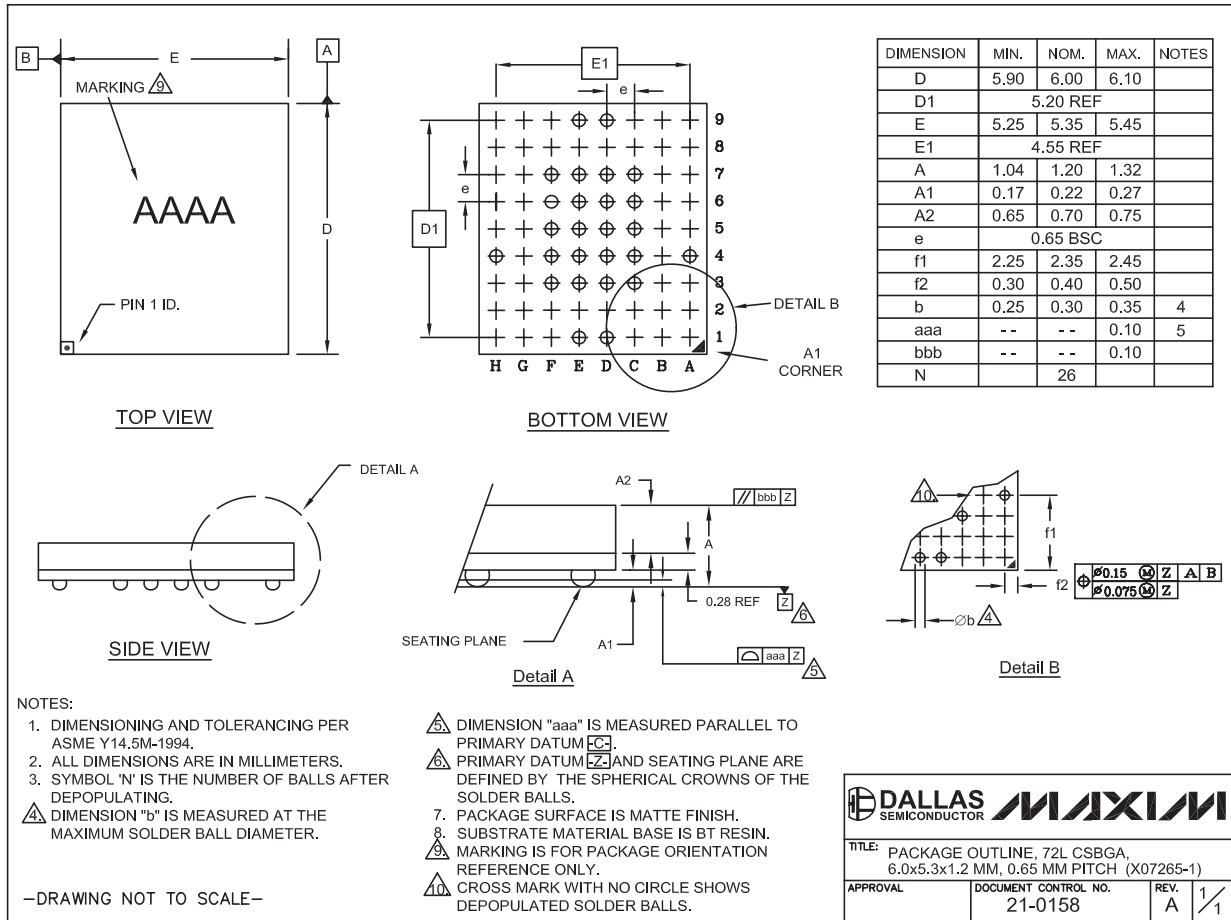

72L CSBGA EPS

MAX4800/MAX4801/MAX4802

# Low-Charge Injection, 8-Channel, High-Voltage Analog Switches

## Package Information (continued)

(The package drawing(s) in this data sheet may not reflect the most current specifications. For the latest package outline information, go to [www.maxim-ic.com/packages](http://www.maxim-ic.com/packages).)

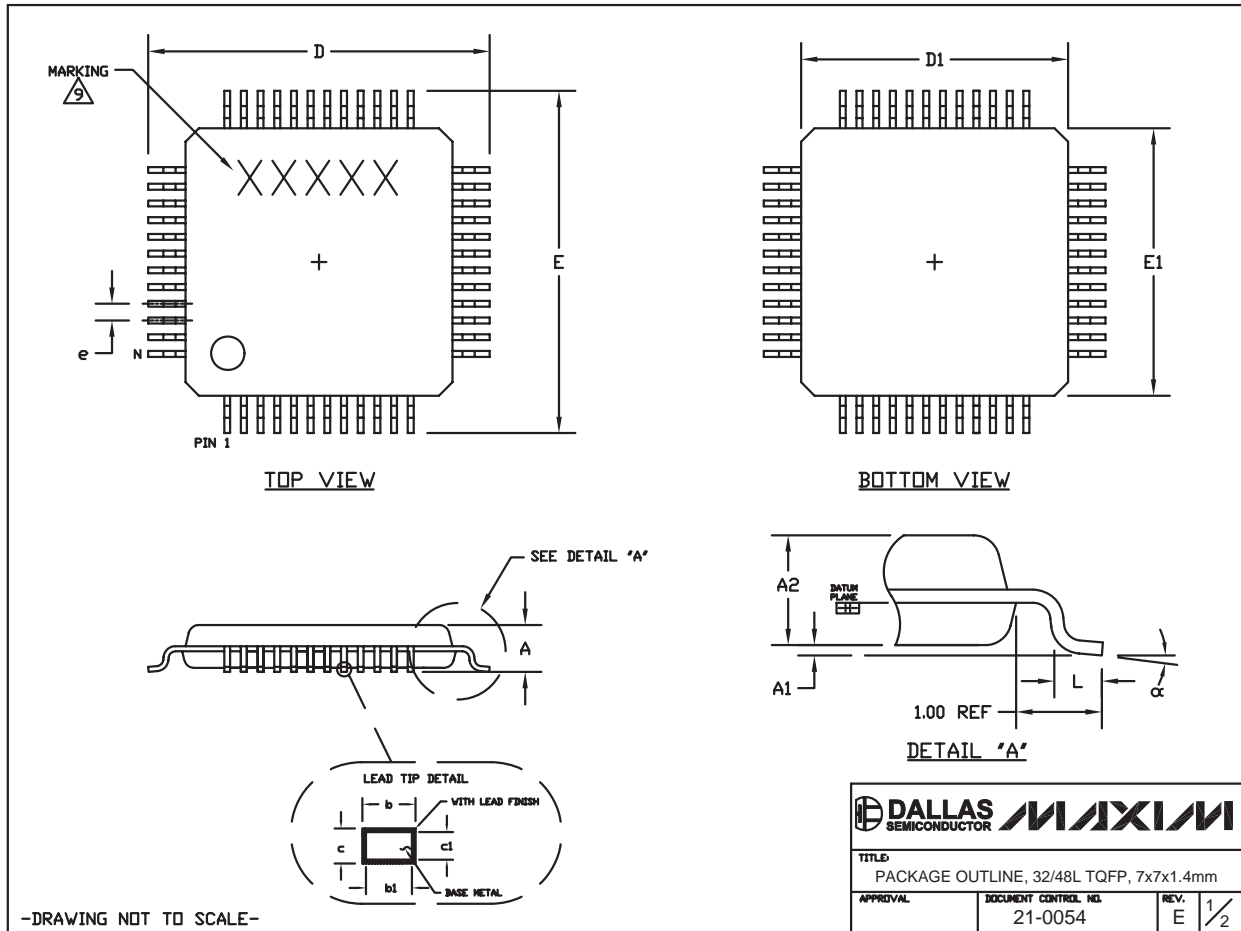

TQFPPO.EPS

TITLE: PACKAGE OUTLINE, 32/48L TQFP, 7x7x1.4mm		
APPROVAL:	DOCUMENT CONTROL NO: 21-0054	REV: E 1/2

# Low-Charge Injection, 8-Channel, High-Voltage Analog Switches

## Package Information (continued)

(The package drawing(s) in this data sheet may not reflect the most current specifications. For the latest package outline information, go to [www.maxim-ic.com/packages](http://www.maxim-ic.com/packages).)

MAX4800/MAX4801/MAX4802

### NOTES:

1. ALL DIMENSIONING AND TOLERANCING CONFORM TO ANSI Y14.5-1982.
2. DATUM PLANE  $\square$  IS LOCATED AT MOLD PARTING LINE AND COINCIDENT WITH LEAD, WHERE LEAD EXITS PLASTIC BODY AT BOTTOM OF PARTING LINE.
3. DIMENSIONS D1 AND E1 DO NOT INCLUDE MOLD PROTRUSION. ALLOWABLE MOLD PROTRUSION IS 0.25 MM ON D1 AND E1 DIMENSIONS.
4. THE TOP OF PACKAGE IS SMALLER THAN THE BOTTOM OF PACKAGE BY 0.15 MILLIMETERS.
5. DIMENSION b DOES NOT INCLUDE DAMBAR PROTRUSION. ALLOWABLE DAMBAR PROTRUSION SHALL BE 0.08 MM TOTAL IN EXCESS OF THE b DIMENSION AT MAXIMUM MATERIAL CONDITION.
6. ALL DIMENSIONS ARE IN MILLIMETERS.
7. THIS OUTLINE CONFORMS TO JEDEC PUBLICATION 95, REGISTRATION MS-026.
8. LEADS SHALL BE COPLANAR WITHIN .004 INCH.
9. MARKING SHOWN IS FOR PACKAGE ORIENTATION REFERENCE ONLY.
10. NUMBER OF LEADS ARE SHOWN FOR REFERENCE ONLY.

	BBA		BBC	
	MIN.	MAX.	MIN.	MAX.
A	--	1.60	--	1.60
A1	0.05	0.15	0.05	0.15
A2	1.35	1.45	1.35	1.45
D	8.90	9.10	8.90	9.10
D1	6.90	7.10	6.90	7.10
E	8.90	9.10	8.90	9.10
E1	6.90	7.10	6.90	7.10
e	0.8 BSC.		0.5 BSC.	
L	0.45	0.75	0.45	0.75
b	0.30	0.45	0.17	0.27
b1	0.30	0.40	0.17	0.23
c	0.09	0.20	0.09	0.20
c1	0.09	0.16	0.09	0.16
N	32		48	
$\alpha$	0°	7°	0°	7°

-DRAWING NOT TO SCALE-

	
<b>TITLE:</b> PACKAGE OUTLINE, 32/48L TQFP, 7x7x1.4mm	
<b>APPROVAL</b>	<b>DOCUMENT CONTROL NO.</b> 21-0054
<b>REV.</b> E	<b>REV.</b> 2/2

# Low-Charge Injection, 8-Channel, High-Voltage Analog Switches

## Package Information (continued)

(The package drawing(s) in this data sheet may not reflect the most current specifications. For the latest package outline information, go to [www.maxim-ic.com/packages](http://www.maxim-ic.com/packages).)

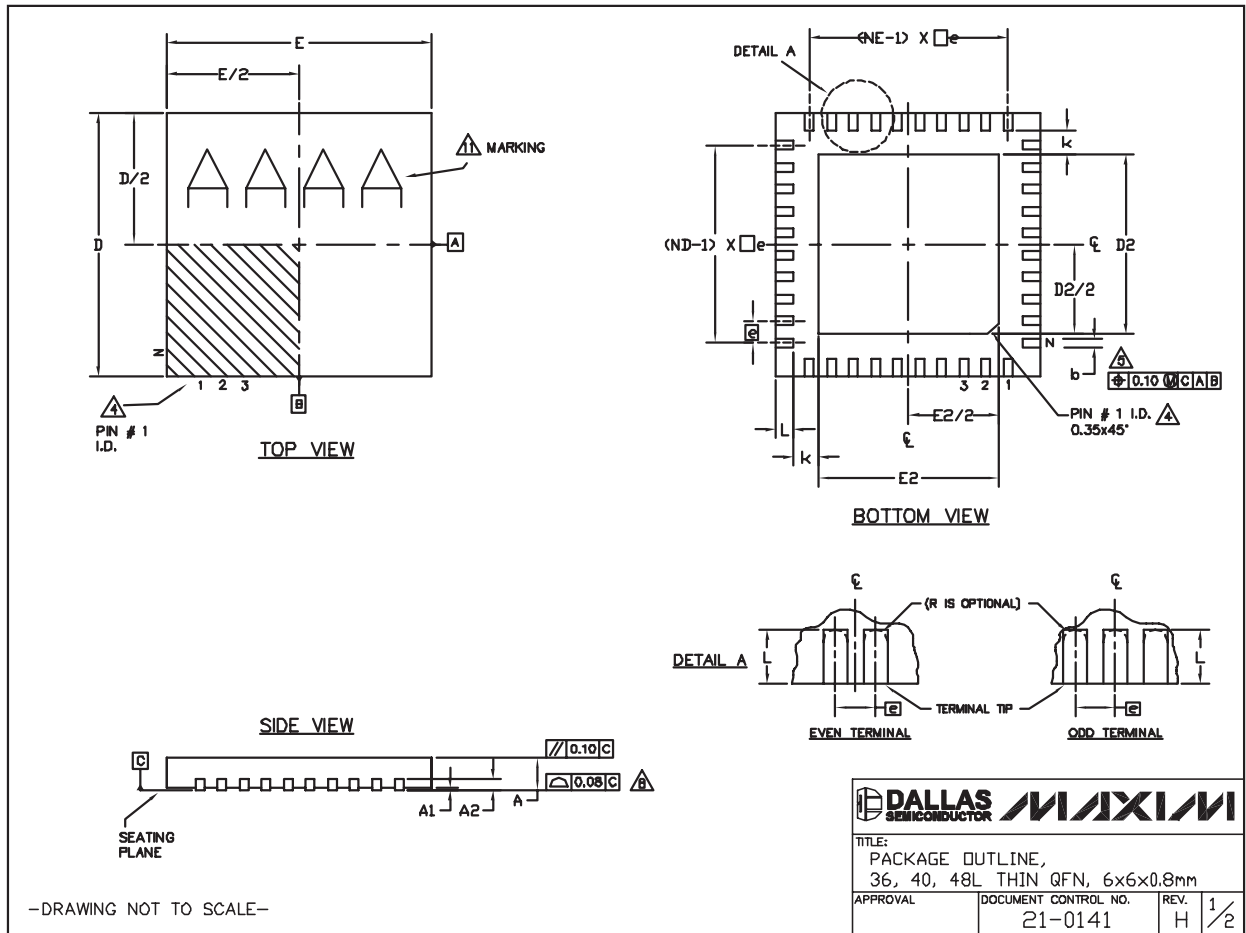

# Low-Charge, Injection 8-Channel, High-Voltage Analog Switches

## Package Information (continued)

(The package drawing(s) in this data sheet may not reflect the most current specifications. For the latest package outline information, go to [www.maxim-ic.com/packages](http://www.maxim-ic.com/packages).)

MAX4800/MAX4801/MAX4802

COMMON DIMENSIONS									
PKG.	36L 6x6			40L 6x6			48L 6x6		
SYMBOL	MIN.	NOM.	MAX.	MIN.	NOM.	MAX.	MIN.	NOM.	MAX.
A	0.70	0.75	0.80	0.70	0.75	0.80	0.70	0.75	0.80
A1	0	0.02	0.05	0	0.02	0.05	0	-	0.05
A2	0.20 REF.			0.20 REF.			0.20 REF.		
b	0.20	0.25	0.30	0.20	0.25	0.30	0.15	0.20	0.25
D	5.90	6.00	6.10	5.90	6.00	6.10	5.90	6.00	6.10
E	5.90	6.00	6.10	5.90	6.00	6.10	5.90	6.00	6.10
e	0.50 BSC.			0.50 BSC.			0.40 BSC.		
k	0.25	-	-	0.25	-	-	0.25	-	-
L	0.45	0.55	0.65	0.30	0.40	0.50	0.30	0.40	0.50
N	36			40			48		
ND	9			10			12		
NE	9			10			12		
JEDEC	WJJD-1			WJJD-2			-		

EXPOSED PAD VARIATIONS						
PKG. CODES	D2			E2		
	MIN.	NOM.	MAX.	MIN.	NOM.	MAX.
T3666-2	3.60	3.70	3.80	3.60	3.70	3.80
T3666-3	3.60	3.70	3.80	3.60	3.70	3.80
T3666N-1	3.60	3.70	3.80	3.60	3.70	3.80
T3666MN-1	3.60	3.70	3.80	3.60	3.70	3.80
T4066-2	4.00	4.10	4.20	4.00	4.10	4.20
T4066-3	4.00	4.10	4.20	4.00	4.10	4.20
T4066-4	4.00	4.10	4.20	4.00	4.10	4.20
T4066-5	4.00	4.10	4.20	4.00	4.10	4.20
T4866-1	4.40	4.50	4.60	4.40	4.50	4.60
T4866-2	4.40	4.50	4.60	4.40	4.50	4.60

### NOTES:

- DIMENSIONING & TOLERANCING CONFORM TO ASME Y14.5M-1994.
- ALL DIMENSIONS ARE IN MILLIMETERS. ANGLES ARE IN DEGREES.
- N IS THE TOTAL NUMBER OF TERMINALS.
- THE TERMINAL #1 IDENTIFIER AND TERMINAL NUMBERING CONVENTION SHALL CONFORM TO JESD 95-1 SPP-012. DETAILS OF TERMINAL #1 IDENTIFIER ARE OPTIONAL, BUT MUST BE LOCATED WITHIN THE ZONE INDICATED. THE TERMINAL #1 IDENTIFIER MAY BE EITHER A MOLD OR MARKED FEATURE.
- DIMENSION b APPLIES TO METALLIZED TERMINAL AND IS MEASURED BETWEEN 0.25 mm AND 0.30 mm FROM TERMINAL TIP.
- ND AND NE REFER TO THE NUMBER OF TERMINALS ON EACH D AND E SIDE RESPECTIVELY.
- DEPOPULATION IS POSSIBLE IN A SYMMETRICAL FASHION.
- COPLANARITY APPLIES TO THE EXPOSED HEAT SINK SLUG AS WELL AS THE TERMINALS.
- DRAWING CONFORMS TO JEDEC MO220, EXCEPT FOR 0.4mm LEAD PITCH PACKAGE T4866-1.
- WARPAGE SHALL NOT EXCEED 0.10 mm.
- MARKING IS FOR PACKAGE ORIENTATION REFERENCE ONLY.
- NUMBER OF LEADS SHOWN FOR REFERENCE ONLY.

-DRAWING NOT TO SCALE-

TITLE: PACKAGE OUTLINE, 36, 40, 48L THIN QFN, 6x6x0.8mm	
APPROVAL	DOCUMENT CONTROL NO. 21-0141
REV. H	2/2

## Revision History

Pages changed at Rev 1: 1, 7, 8, 14, 18, 19, 20, 21

Maxim cannot assume responsibility for use of any circuitry other than circuitry entirely embodied in a Maxim product. No circuit patent licenses are implied. Maxim reserves the right to change the circuitry and specifications without notice at any time.

Maxim Integrated Products, 120 San Gabriel Drive, Sunnyvale, CA 94086 408-737-7600 \_\_\_\_\_ 21