

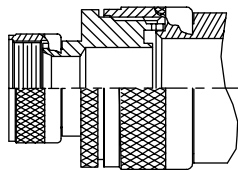

## AS85049/7 and MS3189B Environmental Backshells

### Glenair Connector Designator A

**MIL-DTL-5015 Series 3400,  
MIL-DTL-26482 Series 2,  
AS81703 Series 3,  
MIL-DTL-83723 Series I &  
III, 40M39569, DEF 5326-3,  
EN 2997, EN 3646,  
ESC 10, ESC 11, LN 29504,  
NFC93422 Series HE302,  
PAN 6432-1, PAN 6432-2,  
PATT 602**



**STYLE 2**

1. For complete dimensions see applicable Military Specification.
2. Metric dimensions (mm) are indicated in parentheses.
3. When maximum cable entry is exceeded, Style 2 will be supplied.
4. Cable range is defined as the accommodations range for the wire bundle or cable.  
Dimensions shown are not intended for inspection criteria.

**M85049/7-21 N**  
Basic Part No. \_\_\_\_\_  
Dash No. \_\_\_\_\_

Finish and Material  
B = Black Cadmium, Stainless Steel  
N = Electroless Nickel, Aluminum  
S = Passivated Stainless Steel  
W = 1,000 Hr. Cad. Olive Drab Over Electroless Nickel

**MS3189B 21 N** **Superceded Part Number**  
Basic Part No. \_\_\_\_\_  
Dash No. \_\_\_\_\_

Finish (Material is Aluminum Only)  
A = Cadmium Olive Drab over Nickel  
C = Cadmium Olive Drab  
N = Electroless Nickel

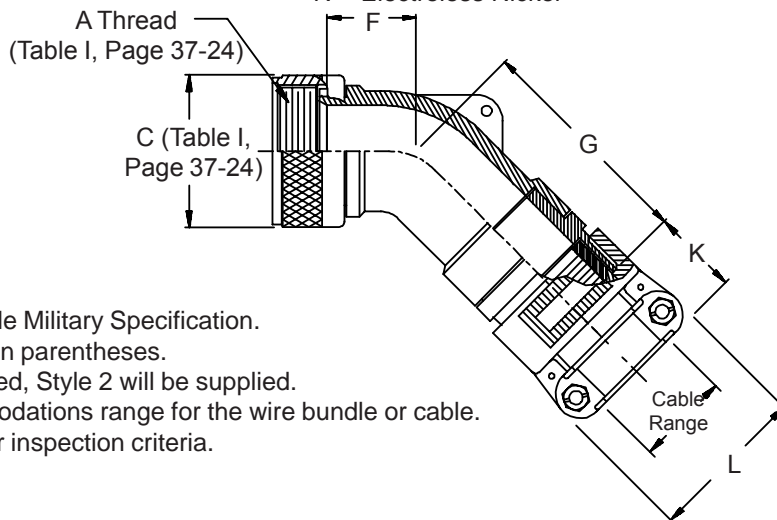

**TABLE II**

Dash No.	Shell Size	F		G		K		L		Cable Range		M85049/42 Ref		
		Max	(mm)	Max	(mm)	Ref.	(mm)	Max	(mm)	Min	Max			
1	03	.688	(17.5)	1.852	(47.0)	1.027	(26.1)	.957	(24.3)	.125	(3.2)	.250	(6.4)	4
2	03	1.500	(38.1)	1.972	(50.1)	1.027	(26.1)	1.145	(29.1)	.250	(6.4)	.437	(11.1)	6
3	08	.625	(15.9)	1.244	(31.6)	1.027	(26.1)	.957	(24.3)	.125	(3.2)	.250	(6.4)	4
4	10	.688	(17.5)	1.912	(48.6)	1.027	(26.1)	.957	(24.3)	.125	(3.2)	.312	(7.9)	4
5	10	.688	(17.5)	1.307	(33.2)	1.027	(26.1)	1.145	(29.1)	.250	(6.4)	.375	(9.5)	6
6	12	.750	(19.1)	1.972	(50.1)	1.027	(26.1)	.957	(24.3)	.125	(3.2)	.312	(7.9)	4
7	12	.750	(19.1)	1.972	(50.1)	1.027	(26.1)	1.145	(29.1)	.250	(6.4)	.437	(11.1)	6
8	12	.750	(19.1)	1.972	(50.1)	1.027	(26.1)	1.332	(33.8)	.350	(8.9)	.500	(12.7)	10
9	14	.812	(20.6)	2.062	(52.4)	1.027	(26.1)	1.145	(29.1)	.250	(6.4)	.437	(11.1)	6
10	14	.812	(20.6)	1.717	(43.6)	1.027	(26.1)	1.332	(33.8)	.350	(8.9)	.575	(14.6)	10
11	16	.906	(23.0)	2.172	(55.2)	1.027	(26.1)	1.145	(29.1)	.250	(6.4)	.437	(11.1)	6
12	16	.906	(23.0)	1.812	(46.0)	1.059	(26.9)	1.551	(39.4)	.500	(12.7)	.700	(17.8)	12
13	18	1.093	(27.8)	2.362	(60.0)	1.027	(26.1)	1.332	(33.8)	.350	(8.9)	.625	(15.9)	10
14	18	1.093	(27.8)	2.000	(50.8)	1.156	(29.4)	1.770	(45.0)	.625	(15.9)	.779	(19.8)	16
15	20	1.093	(27.8)	2.362	(60.0)	1.027	(26.1)	1.332	(33.8)	.350	(8.9)	.625	(15.9)	10
16	20	1.093	(27.8)	2.000	(50.8)	1.156	(29.4)	1.770	(45.0)	.625	(15.9)	.904	(23.0)	16
17	22	1.188	(30.2)	2.512	(63.8)	1.059	(26.9)	1.551	(39.4)	.500	(12.7)	.750	(19.1)	12
18	22	1.188	(30.2)	2.155	(54.7)	1.375	(34.9)	2.113	(53.7)	.875	(22.2)	1.029	(26.1)	20
19	24	1.188	(30.2)	2.512	(63.8)	1.059	(26.9)	1.551	(39.4)	.500	(12.7)	.750	(19.1)	12
20	24	1.188	(30.2)	2.155	(54.7)	1.375	(34.9)	2.113	(53.7)	.875	(22.2)	1.144	(29.1)	20
21	28	1.312	(33.3)	2.562	(65.1)	1.156	(33.7)	1.770	(45.0)	.625	(15.9)	.937	(23.8)	16

# AS85049/7 and MS3189B Environmental Backshells



Environmental  
Backshells

**TABLE II (Continued)**

Dash No.	Shell Size	F		G		K Ref.	L Max	Cable Range				M85049/42 Ref		
		Max	( )	Max	( )			Min	( )	Max	( )			
22	28	1.312	(33.3)	2.218	(56.3)	1.500	(38.1)	2.363	(60.0)	1.000	(25.4)	1.375	(34.9)	24
23	32	1.375	(34.9)	2.662	(67.6)	1.156	(29.4)	1.770	(45.0)	.625	(15.9)	.937	(23.8)	16
24	32	1.375	(34.9)	2.662	(67.6)	1.375	(34.9)	2.113	(53.7)	.875	(22.2)	1.250	(31.8)	20
25	32	1.375	(34.9)	2.312	(58.7)	1.781	(45.2)	2.770	(70.4)	1.250	(31.8)	1.625	(41.3)	28
26	36	1.406	(35.7)	2.752	(69.9)	1.156	(29.4)	1.770	(45.0)	.625	(15.9)	.937	(23.8)	16
27	36	1.406	(35.7)	2.752	(69.9)	1.500	(38.1)	2.363	(60.0)	1.000	(25.4)	1.375	(34.9)	24
28	36	1.406	(35.7)	2.406	(61.1)	1.830	(46.5)	3.020	(76.7)	1.437	(36.5)	1.840	(46.7)	32
29	40	2.156	(54.8)	2.752	(69.9)	1.156	(29.4)	1.770	(45.0)	.625	(15.9)	.937	(23.8)	16
30	40	2.156	(54.8)	2.752	(69.9)	1.500	(38.1)	2.363	(60.0)	1.000	(25.4)	1.375	(34.9)	24
31	40	2.156	(54.8)	2.406	(61.1)	1.830	(46.5)	3.020	(76.7)	1.437	(36.5)	1.875	(47.6)	32
32	44	2.156	(54.8)	2.752	(69.9)	1.156	(29.4)	1.770	(45.0)	.625	(15.9)	.937	(23.8)	16
33	44	2.156	(54.8)	2.752	(69.9)	1.500	(38.1)	2.363	(60.0)	1.000	(25.4)	1.375	(34.9)	24
34	44	2.156	(54.8)	2.406	(61.1)	1.830	(46.5)	3.020	(76.7)	1.437	(36.5)	1.875	(47.6)	32
35	48	2.156	(54.8)	2.752	(69.9)	1.156	(29.4)	1.770	(45.0)	.625	(15.9)	.937	(23.8)	16
36	48	2.156	(54.8)	2.752	(69.9)	1.500	(38.1)	2.363	(60.0)	1.000	(25.4)	1.375	(34.9)	24
37	48	2.156	(54.8)	2.406	(61.1)	1.830	(46.5)	3.020	(76.7)	1.437	(36.5)	1.875	(47.6)	32
38	61	1.188	(30.2)	2.512	(63.8)	1.059	(26.9)	1.551	(39.4)	.500	(12.7)	.750	(19.1)	12
39	61	1.188	(30.2)	2.155	(54.7)	1.375	(34.9)	2.113	(53.7)	.875	(22.2)	1.184	(30.1)	20
40	16	.906	(23.0)	2.172	(55.2)	1.027	(26.1)	1.332	(33.8)	.350	(8.9)	.625	(15.9)	10
41	18	1.093	(27.8)	2.362	(60.0)	1.027	(26.1)	.957	(24.3)	.125	(3.2)	.312	(7.9)	4
42	18	1.093	(27.8)	2.362	(60.0)	1.027	(26.1)	1.145	(29.1)	.250	(6.4)	.437	(11.1)	6
43	20	1.093	(27.8)	2.362	(60.0)	1.027	(26.1)	1.145	(29.1)	.250	(6.4)	.437	(11.1)	6
44	22	1.188	(30.2)	2.512	(63.8)	1.027	(26.1)	.957	(24.3)	.125	(3.2)	.312	(7.9)	4
45	22	1.188	(30.2)	2.512	(63.8)	1.027	(26.1)	1.145	(29.1)	.250	(6.4)	.437	(11.1)	6
46	24	1.188	(30.2)	2.512	(63.8)	1.027	(26.1)	1.332	(33.8)	.350	(8.9)	.625	(15.9)	10
47	36	1.406	(35.7)	2.752	(69.9)	1.059	(26.9)	1.551	(39.4)	.500	(12.7)	.750	(19.1)	12
48	40	2.156	(54.8)	2.752	(69.9)	1.059	(26.9)	1.551	(39.4)	.500	(12.7)	.750	(19.1)	12
49*	10	1.500	(38.1)	1.972	(50.1)	1.027	(26.1)	1.145	(29.1)	.250	(6.4)	.437	(11.1)	6
50*	14	1.842	(46.8)	2.362	(60.0)	1.059	(26.9)	1.551	(39.4)	.500	(12.7)	.750	(19.1)	12
51*	16	1.938	(49.2)	2.512	(63.8)	1.156	(29.4)	1.770	(45.0)	.625	(15.9)	.937	(23.8)	16
52	18	1.093	(27.8)	2.362	(60.0)	1.059	(26.9)	1.551	(39.4)	.500	(12.7)	.750	(19.1)	12
53	61	1.188	(30.2)	2.512	(63.8)	1.156	(29.4)	1.770	(45.0)	.625	(15.9)	.937	(23.8)	16
54	20	1.093	(27.8)	2.362	(60.0)	1.059	(26.9)	1.551	(39.4)	.500	(12.7)	.750	(19.1)	12
55*	20	2.061	(52.3)	2.562	(65.1)	1.375	(34.9)	2.113	(53.7)	.875	(22.2)	1.250	(31.8)	20
56	22	1.188	(30.2)	2.512	(63.8)	1.027	(26.1)	1.332	(33.8)	.350	(8.9)	.625	(15.9)	10
57	22	1.188	(30.2)	2.512	(63.8)	1.156	(29.4)	1.770	(45.0)	.625	(15.9)	.937	(23.8)	16
58*	22	2.061	(52.3)	2.562	(65.1)	1.375	(34.9)	2.113	(53.7)	.875	(22.2)	1.250	(31.8)	20
59	24	1.188	(30.2)	2.512	(63.8)	1.156	(29.4)	1.770	(45.0)	.625	(15.9)	.937	(23.8)	16
60	28	1.312	(33.3)	2.562	(65.1)	1.059	(26.9)	1.551	(39.4)	.500	(12.7)	.750	(19.1)	12
61	28	1.312	(33.3)	2.562	(65.1)	1.375	(34.9)	2.113	(53.7)	.875	(22.2)	1.250	(31.8)	20
62	32	1.375	(34.9)	2.662	(67.6)	1.500	(38.1)	2.363	(60.0)	1.000	(25.4)	1.375	(34.9)	24
63	36	1.406	(35.7)	2.752	(69.9)	1.375	(34.9)	2.113	(53.7)	.875	(22.2)	1.250	(31.8)	20
64	36	1.406	(35.7)	2.752	(69.9)	1.781	(45.2)	2.770	(70.4)	1.250	(31.8)	1.625	(41.3)	28
65	40	2.156	(54.8)	2.752	(69.9)	1.375	(34.9)	2.113	(53.7)	.875	(22.2)	1.250	(31.8)	20
66	40	2.156	(54.8)	2.752	(69.9)	1.781	(45.2)	2.770	(70.4)	1.250	(31.8)	1.625	(41.3)	28
67	44	2.156	(54.8)	2.752	(69.9)	1.375	(34.9)	2.113	(53.7)	.875	(22.2)	1.250	(31.8)	20
68	44	2.156	(54.8)	2.752	(69.9)	1.781	(45.2)	2.770	(70.4)	1.250	(31.8)	1.625	(41.3)	28
69	48	2.156	(54.8)	2.752	(69.9)	1.375	(34.9)	2.113	(53.7)	.875	(22.2)	1.250	(31.8)	20
70	48	2.156	(54.8)	2.752	(69.9)	1.781	(45.2)	2.770	(70.4)	1.250	(31.8)	1.625	(41.3)	28
71*	12	1.654	(42.0)	2.173	(55.2)	1.027	(26.1)	1.332	(33.8)	.350	(8.9)	.625	(15.9)	10
72*	18	1.938	(49.2)	2.512	(63.8)	1.156	(29.4)	1.770	(45.0)	.625	(15.9)	.937	(23.8)	16
73*	24	2.061	(52.3)	2.562	(65.1)	1.375	(34.9)	2.113	(53.7)	.875	(22.2)	1.250	(31.8)	20
74	14	.812	(20.6)	2.062	(52.4)	1.027	(26.1)	.957	(24.3)	.125	(3.2)	.312	(7.9)	4
75	16	.906	(23.0)	2.172	(55.2)	1.027	(26.1)	.957	(24.3)	.125	(3.2)	.312	(7.9)	4

© 2005 Glenair, Inc.

CAGE Code 06324

Printed in U.S.A.

**GLENAIR, INC. • 1211 AIR WAY • GLENDALE, CA 91201-2497 • 818-247-6000 • FAX 818-500-9912**  
**www.glenair.com**      \* Denotes Style 2      **37-21**      **E-Mail: sales@glenair.com**