

Customer Information Sheet

DRAWING No. M60-606XX45

SHEET 2 OF 2

IF IN DOUBT - ASK

(C)

NOT TO SCALE

THIRD ANGLE PROJECTION

ALL DIMENSIONS IN mm

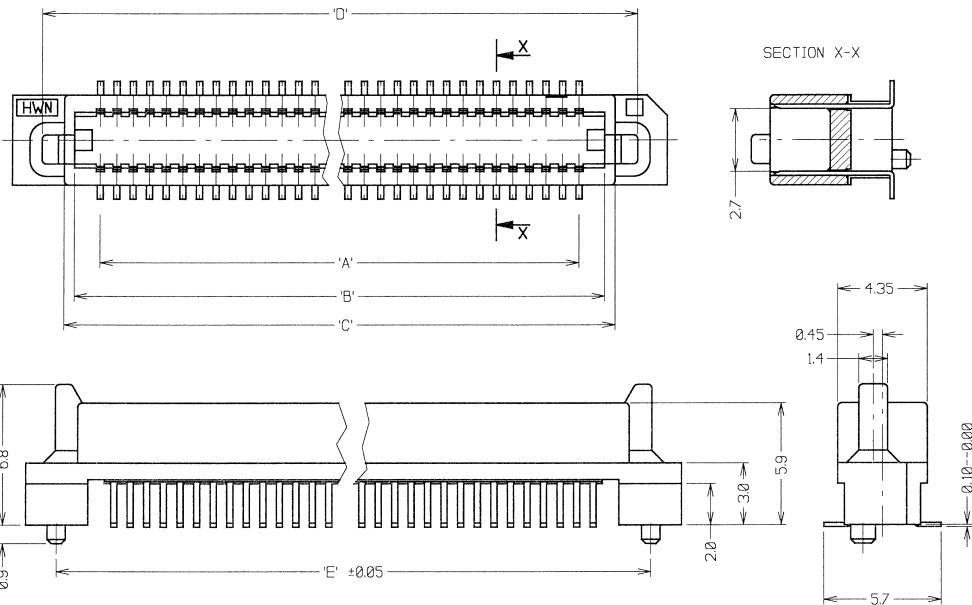

PART No.	No. OF CONTACTS	'A'	'B'	'C'	'D'	'E'	'F'
M60-6061045	10 + 10	7.2	9.7	10.7	12.9	12.8	15.8
M60-6061545	15 + 15	11.2	13.7	14.7	16.9	16.8	19.8
M60-6062045	20 + 20	15.2	17.7	18.7	20.9	20.8	23.8
M60-6062545	25 + 25	19.2	21.7	22.7	24.9	24.8	27.8
M60-6063045	30 + 30	23.2	25.7	26.7	28.9	28.8	31.8
M60-6064045	40 + 40	31.2	33.7	34.7	36.9	36.8	39.8
M60-6065045	50 + 50	39.2	41.7	42.7	44.9	44.8	47.8

SPECIFICATIONS:

MATERIAL:
 MOULDING = LCP, UL94V-0
 CONTACTS = PHOSPHOR BRONZE

FINISH:
 CONTACTS:
 0.05µ MIN GOLD OVER 127µ MIN NICKEL
 0.5µ MIN GOLD ON CONTACT AREA.

ELECTRICAL:
 CURRENT RATING = 0.5 AMPS
 VOLTAGE RATING = 100V AC
 DIELECTRIC WITHSTANDING VOLTAGE = 300V AC (1 MINUTE)
 INSULATION RESISTANCE = 1000 MEGOHMS MIN (250V DC)
 CONTACT RESISTANCE = 40 MILLIOHMS MAX

MECHANICAL:
 DURABILITY = 30 CYCLES

ENVIRONMENTAL:
 TEMPERATURE RANGE = -55°C TO +100°C
 PACKING = TUBE

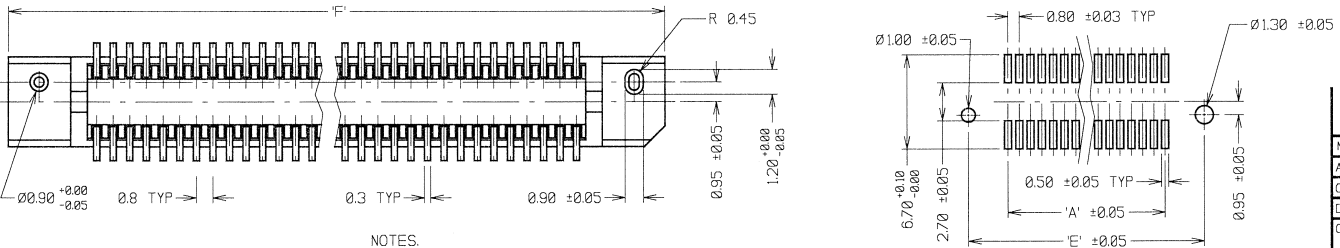

- NOTES:**
- MATES WITH M60-614XX45 OR M60-616XX45 TO GIVE BOARD-TO-BOARD HEIGHTS OF 7mm AND 9mm RESPECTIVELY.
 - ALL TOLERANCES ±0.30 UNLESS OTHERWISE STATED.

JMB	9	17.07.06	9324
NAME	ISS.	DATE	C/NOTE
APPROVED:	J.S.		
CHECKED:	W.J.B.		
DRAWN:	WJ BOURNE		
CUSTOMER REF.:			
ASSEMBLY DRG.:			

ORDER CODE: **M60-606XX45**

No. OF CONTACTS PER ROW
 10, 15, 20, 25, 30, 40, 50

HARWIN

HARWIN USA TEL: 603 893 5376 FAX: 603 893 5396 mis@harwin.com	HARWIN Europe (UK) TEL: 023 9231 4545 FAX: 023 9231 4590 mis@harwin.co.uk	HARWIN Asia TEL: +65 6 779 4909 FAX: +65 6 779 3668 mis@harwin.com.sg
--	--	--

THIS DRAWING AND ANY INFORMATION OR DESCRIPTIVE MATTER SET OUT HEREON ARE CONFIDENTIAL AND COPYRIGHT PROPERTY OF THE HARWIN GROUP AND MUST NOT BE DISCLOSED, LOANED, COPIED OR USED FOR MANUFACTURING, TENDERING OR FOR ANY OTHER PURPOSE WITHOUT THEIR WRITTEN PERMISSION.

TOLERANCES
X = ±1mm
X.X = ±0.25mm
X.XX = ±0.10mm
X.XXX = ±0.05mm
ANGLES = ±5° UNLESS STATED

MATERIAL:
SEE ABOVE

FINISH: SEE ABOVE

S/AREA: mm²

TITLE: 0.80mm PITCH SMT SOCKET CONNECTOR (6mm HIGH)

DRAWING NUMBER: M60-606XX45

SHT 2 OF 2