

To our customers,

Old Company Name in Catalogs and Other Documents

On April 1st, 2010, NEC Electronics Corporation merged with Renesas Technology Corporation, and Renesas Electronics Corporation took over all the business of both companies. Therefore, although the old company name remains in this document, it is a valid Renesas Electronics document. We appreciate your understanding.

Renesas Electronics website: <http://www.renesas.com>

April 1st, 2010
Renesas Electronics Corporation

Issued by: Renesas Electronics Corporation (<http://www.renesas.com>)

Send any inquiries to <http://www.renesas.com/inquiry>.



Notice

1. All information included in this document is current as of the date this document is issued. Such information, however, is subject to change without any prior notice. Before purchasing or using any Renesas Electronics products listed herein, please confirm the latest product information with a Renesas Electronics sales office. Also, please pay regular and careful attention to additional and different information to be disclosed by Renesas Electronics such as that disclosed through our website.
2. Renesas Electronics does not assume any liability for infringement of patents, copyrights, or other intellectual property rights of third parties by or arising from the use of Renesas Electronics products or technical information described in this document. No license, express, implied or otherwise, is granted hereby under any patents, copyrights or other intellectual property rights of Renesas Electronics or others.
3. You should not alter, modify, copy, or otherwise misappropriate any Renesas Electronics product, whether in whole or in part.
4. Descriptions of circuits, software and other related information in this document are provided only to illustrate the operation of semiconductor products and application examples. You are fully responsible for the incorporation of these circuits, software, and information in the design of your equipment. Renesas Electronics assumes no responsibility for any losses incurred by you or third parties arising from the use of these circuits, software, or information.
5. When exporting the products or technology described in this document, you should comply with the applicable export control laws and regulations and follow the procedures required by such laws and regulations. You should not use Renesas Electronics products or the technology described in this document for any purpose relating to military applications or use by the military, including but not limited to the development of weapons of mass destruction. Renesas Electronics products and technology may not be used for or incorporated into any products or systems whose manufacture, use, or sale is prohibited under any applicable domestic or foreign laws or regulations.
6. Renesas Electronics has used reasonable care in preparing the information included in this document, but Renesas Electronics does not warrant that such information is error free. Renesas Electronics assumes no liability whatsoever for any damages incurred by you resulting from errors in or omissions from the information included herein.
7. Renesas Electronics products are classified according to the following three quality grades: "Standard", "High Quality", and "Specific". The recommended applications for each Renesas Electronics product depends on the product's quality grade, as indicated below. You must check the quality grade of each Renesas Electronics product before using it in a particular application. You may not use any Renesas Electronics product for any application categorized as "Specific" without the prior written consent of Renesas Electronics. Further, you may not use any Renesas Electronics product for any application for which it is not intended without the prior written consent of Renesas Electronics. Renesas Electronics shall not be in any way liable for any damages or losses incurred by you or third parties arising from the use of any Renesas Electronics product for an application categorized as "Specific" or for which the product is not intended where you have failed to obtain the prior written consent of Renesas Electronics. The quality grade of each Renesas Electronics product is "Standard" unless otherwise expressly specified in a Renesas Electronics data sheets or data books, etc.
 - "Standard": Computers; office equipment; communications equipment; test and measurement equipment; audio and visual equipment; home electronic appliances; machine tools; personal electronic equipment; and industrial robots.
 - "High Quality": Transportation equipment (automobiles, trains, ships, etc.); traffic control systems; anti-disaster systems; anti-crime systems; safety equipment; and medical equipment not specifically designed for life support.
 - "Specific": Aircraft; aerospace equipment; submersible repeaters; nuclear reactor control systems; medical equipment or systems for life support (e.g. artificial life support devices or systems), surgical implantations, or healthcare intervention (e.g. excision, etc.), and any other applications or purposes that pose a direct threat to human life.
8. You should use the Renesas Electronics products described in this document within the range specified by Renesas Electronics, especially with respect to the maximum rating, operating supply voltage range, movement power voltage range, heat radiation characteristics, installation and other product characteristics. Renesas Electronics shall have no liability for malfunctions or damages arising out of the use of Renesas Electronics products beyond such specified ranges.
9. Although Renesas Electronics endeavors to improve the quality and reliability of its products, semiconductor products have specific characteristics such as the occurrence of failure at a certain rate and malfunctions under certain use conditions. Further, Renesas Electronics products are not subject to radiation resistance design. Please be sure to implement safety measures to guard them against the possibility of physical injury, and injury or damage caused by fire in the event of the failure of a Renesas Electronics product, such as safety design for hardware and software including but not limited to redundancy, fire control and malfunction prevention, appropriate treatment for aging degradation or any other appropriate measures. Because the evaluation of microcomputer software alone is very difficult, please evaluate the safety of the final products or system manufactured by you.
10. Please contact a Renesas Electronics sales office for details as to environmental matters such as the environmental compatibility of each Renesas Electronics product. Please use Renesas Electronics products in compliance with all applicable laws and regulations that regulate the inclusion or use of controlled substances, including without limitation, the EU RoHS Directive. Renesas Electronics assumes no liability for damages or losses occurring as a result of your noncompliance with applicable laws and regulations.
11. This document may not be reproduced or duplicated, in any form, in whole or in part, without prior written consent of Renesas Electronics.
12. Please contact a Renesas Electronics sales office if you have any questions regarding the information contained in this document or Renesas Electronics products, or if you have any other inquiries.

(Note 1) "Renesas Electronics" as used in this document means Renesas Electronics Corporation and also includes its majority-owned subsidiaries.

(Note 2) "Renesas Electronics product(s)" means any product developed or manufactured by or for Renesas Electronics.

To all our customers

Regarding the change of names mentioned in the document, such as Mitsubishi Electric and Mitsubishi XX, to Renesas Technology Corp.

The semiconductor operations of Hitachi and Mitsubishi Electric were transferred to Renesas Technology Corporation on April 1st 2003. These operations include microcomputer, logic, analog and discrete devices, and memory chips other than DRAMs (flash memory, SRAMs etc.) Accordingly, although Mitsubishi Electric, Mitsubishi Electric Corporation, Mitsubishi Semiconductors, and other Mitsubishi brand names are mentioned in the document, these names have in fact all been changed to Renesas Technology Corp. Thank you for your understanding. Except for our corporate trademark, logo and corporate statement, no changes whatsoever have been made to the contents of the document, and these changes do not constitute any alteration to the contents of the document itself.

Note : Mitsubishi Electric will continue the business operations of high frequency & optical devices and power devices.

Renesas Technology Corp.
Customer Support Dept.
April 1, 2003

M5M51008DFP,VP,RV,KV -55HI, -70HI

1048576-BIT(131072-WORD BY 8-BIT)CMOS STATIC RAM

DESCRIPTION

The M5M51008DFP,VP,RV,KV are a 1048576-bit CMOS static RAM organized as 131072 word by 8-bit which are fabricated using high-performance quadruple-polysilicon and double metal CMOS technology. The use of thin film transistor (TFT) load cells and CMOS periphery result in a high density and low power static RAM.

They are low standby current and low operation current and ideal for the battery back-up application.

The M5M51008DVP,RV,KV are packaged in a 32-pin thin small outline package which is a high reliability and high density surface mount device(SMD). Two types of devices are available. M5M51008DVP(normal lead bend type package), M5M51008DRV(reverse lead bend type package). Using both types of devices, it becomes very easy to design a printed circuit board.

FEATURES

Type name	Access time (max)	Power supply current	
		Active (1MHz) (max)	stand-by (max)
M5M51008DFP,VP,RV,KV-55H	55ns	15mA (1MHz)	40 μ A (V _{cc} =5.5V)
M5M51008DFP,VP,RV,KV-70H	70ns		

- Directly TTL compatible : All inputs and outputs
- Easy memory expansion and power down by \bar{S}_1, \bar{S}_2
- Data hold on +2V power supply
- Three-state outputs : OR - tie capability
- \bar{OE} prevents data contention in the I/O bus
- Common data I/O
- Package
 - M5M51008DFP 32pin 525mil SOP
 - M5M51008DVP,RV 32pin 8 X 20 mm² TSOP
 - M5M51008DKV 32pin 8 X 13.4 mm² TSOP

APPLICATION

Small capacity memory units

PIN CONFIGURATION (TOP VIEW)

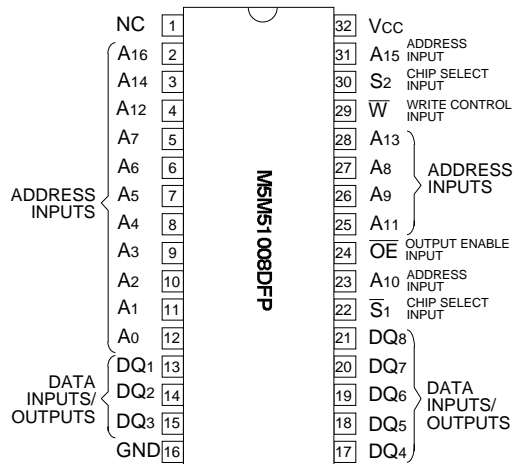

Outline 32P2M-A(FP)

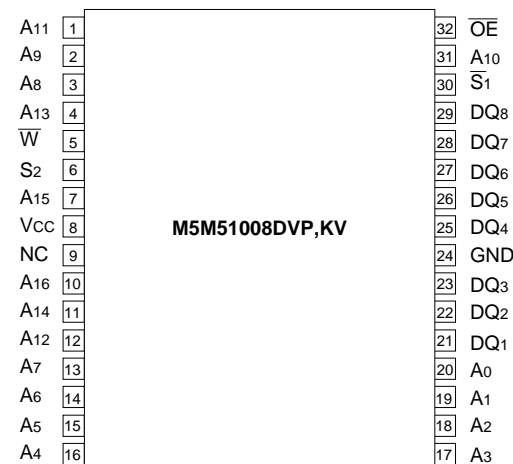

Outline 32P3H-E(VP), 32P3K-B(KV)

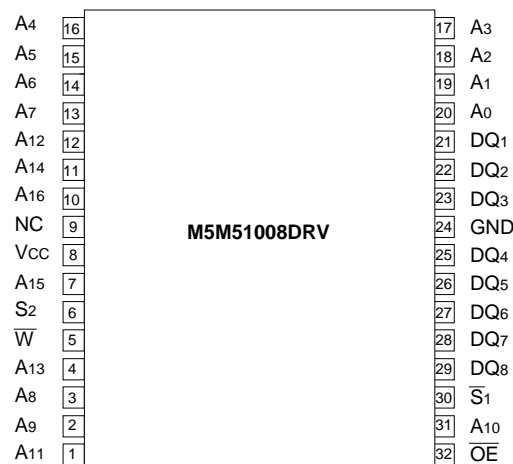

Outline 32P3H-F(RV)

NC : NO CONNECTION

FUNCTION

The operation mode of the M5M51008D series are determined by a combination of the device control inputs $\bar{S}_1, \bar{S}_2, \bar{W}$ and \bar{OE} .

Each mode is summarized in the function table.

A write cycle is executed whenever the low level \bar{W} overlaps with the low level \bar{S}_1 and the high level \bar{S}_2 . The address must be set up before the write cycle and must be stable during the entire cycle. The data is latched into a cell on the trailing edge of \bar{W}, \bar{S}_1 or \bar{S}_2 , whichever occurs first, requiring the set-up and hold time relative to these edge to be maintained. The output enable input \bar{OE} directly controls the output stage. Setting the \bar{OE} at a high level, the output stage is in a high-impedance state, and the data bus contention problem in the write cycle is eliminated.

A read cycle is executed by setting \bar{W} at a high level and \bar{OE} at a low level while \bar{S}_1 and \bar{S}_2 are in an active state ($\bar{S}_1=L, \bar{S}_2=H$).

When setting \bar{S}_1 at a high level or \bar{S}_2 at a low level, the chip are in a non-selectable mode in which both reading and writing are disabled. In this mode, the output stage is in a high-impedance state, allowing OR-tie with other chips and memory expansion by \bar{S}_1 and \bar{S}_2 . The power supply current is reduced as low as the stand-by current which is specified as I_{CC3} or I_{CC4} , and the memory data can be held at +2V power supply, enabling battery back-up operation during power failure or power-down operation in the non-selected mode.

FUNCTION TABLE

\bar{S}_1	\bar{S}_2	\bar{W}	\bar{OE}	Mode	DQ	I_{CC}
X	L	X	X	Non selection	High-impedance	Stand-by
H	X	X	X	Non selection	High-impedance	Stand-by
L	H	L	X	Write	Din	Active
L	H	H	L	Read	Dout	Active
L	H	H	H		High-impedance	Active

Note 1: "H" and "L" in this table mean VIH and VIL, respectively.

2: "X" in this table should be "H" or "L".

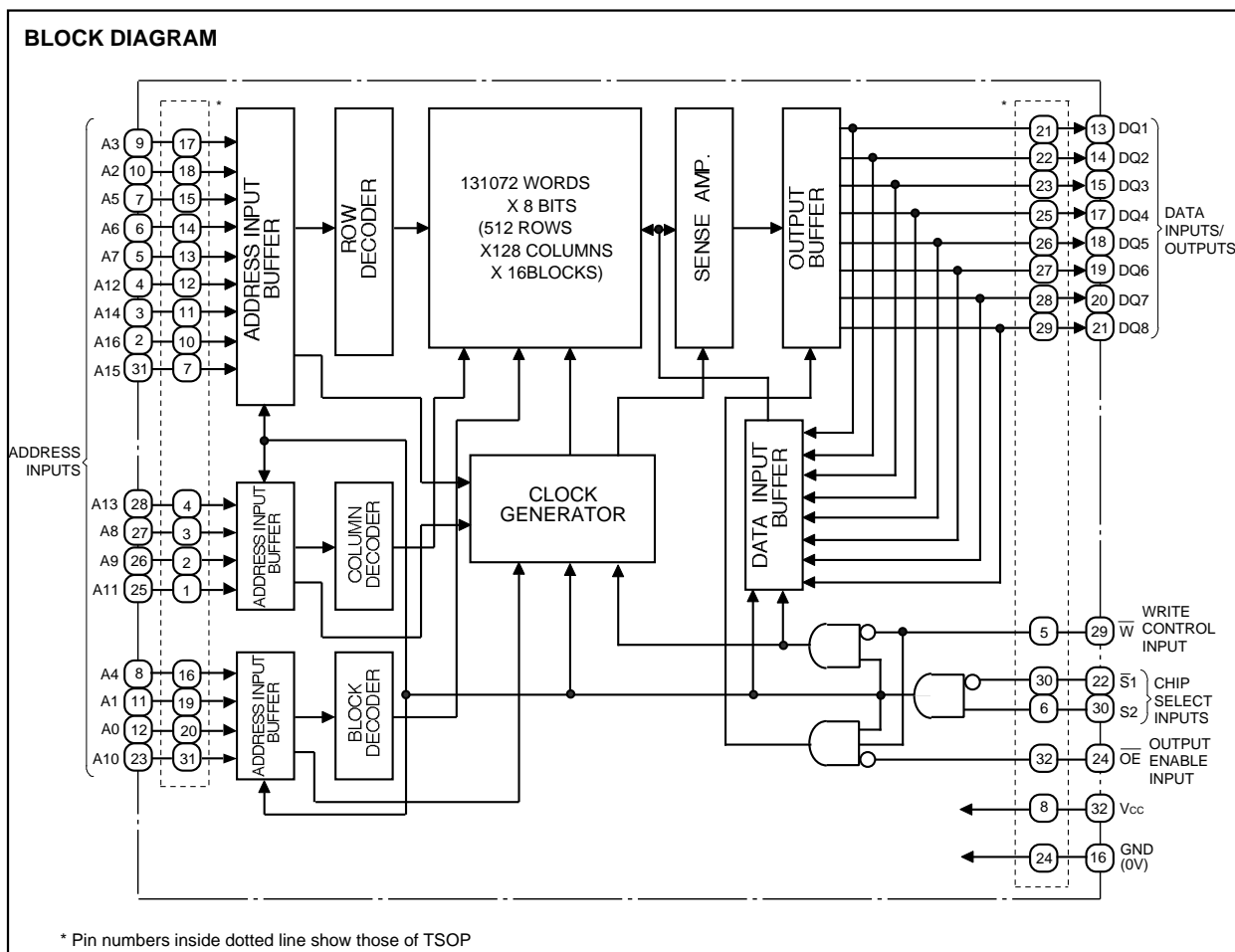

Ver. 1.1
MITSUBISHI LSIs
M5M51008DFP,VP,RV,KV -55HI, -70HI
1048576-BIT(131072-WORD BY 8-BIT)CMOS STATIC RAM

ABSOLUTE MAXIMUM RATINGS

Symbol	Parameter	Conditions	Ratings	Unit
V _{CC}	Supply voltage	With respect to GND	- 0.3*~7	V
V _I	Input voltage		- 0.3*~V _{CC} + 0.3	V
V _O	Output voltage		0~V _{CC}	V
P _d	Power dissipation	T _a =25°C	700	mW
T _{opr}	Operating temperature		- 40~85	°C
T _{stg}	Storage temperature		- 65~150	°C

* -3.0V in case of AC (Pulse width ≤ 50ns)

DC ELECTRICAL CHARACTERISTICS (T_a= -40~85°C, V_{CC}=5V±10%, unless otherwise noted)

Symbol	Parameter	Test conditions	Limits			Unit
			Min	Typ	Max	
V _{IH}	High-level input voltage		2.2		V _{CC} + 0.3	V
V _{IL}	Low-level input voltage		-0.3*		0.8	V
V _{OH}	High-level output voltage	I _{OH} = -1.0mA	2.4			V
		I _{OH} = -0.1mA	V _{CC} - 0.5			V
V _{OL}	Low-level output voltage	I _{OL} =2mA			0.4	V
I _I	Input current	V _I =0~V _{CC}			±1	μA
I _O	Output current in off-state	$\bar{S}_1=V_{IH}$ or $S_2=V_{IL}$ or $\overline{OE}=V_{IH}$ V _{I/O} =0~V _{CC}			±1	μA
I _{CC1}	Active supply current (AC, MOS level)	$\bar{S}_1 \leq 0.2V, S_2 \geq V_{CC}-0.2V$ other inputs ≤ 0.2V or ≥ V _{CC} -0.2V Output-open(duty 100%)	55ns	39	80	mA
			70ns	34	70	
			1MHz	4	15	
I _{CC2}	Active supply current (AC, TTL level)	$\bar{S}_1=V_{IL}, S_2=V_{IH}$, other inputs=V _{IH} or V _{IL} Output-open(duty 100%)	55ns	42	85	mA
			70ns	37	70	
			1MHz	5	15	
I _{CC3}	Stand-by current	1) S ₂ ≤ 0.2V, other inputs=0~V _{CC} 2) $\bar{S}_1 \geq V_{CC}-0.2V$, S ₂ ≥ V _{CC} -0.2V, other inputs=0~V _{CC}	-HI	~25°C	2	μA
				~40°C	6	
				~70°C	20	
				~85°C	40	
I _{CC4}	Stand-by current	$\bar{S}_1=V_{IH}$ or $S_2=V_{IL}$, other inputs=0~V _{CC}			3	mA

* -3.0V in case of AC (Pulse width ≤ 50ns)

CAPACITANCE (T_a= -40~85°C, V_{CC}=5V±10% unless otherwise noted)

Symbol	Parameter	Test conditions	Limits			Unit
			Min	Typ	Max	
C _I	Input capacitance	FP,VP,RV,KV V _I =GND, V _I =25mVrms, f=1MHz			8	pF
C _O	Output capacitance	FP,VP,RV,KV V _O =GND, V _O =25mVrms, f=1MHz			10	pF

Note 3: Direction for current flowing into an IC is positive (no mark).

4: Typical value is V_{CC} = 5V, T_a = 25°C

Ver. 1.1
MITSUBISHI LSIs
M5M51008DFP,VP,RV,KV -55HI, -70HI
1048576-BIT(131072-WORD BY 8-BIT)CMOS STATIC RAM

AC ELECTRICAL CHARACTERISTICS (Ta= -40~85°C, 5V±10% unless otherwise noted)

(1) MEASUREMENT CONDITIONS

Input pulse level $V_{IH}=2.4V, V_{IL}=0.6V$ (-70HI)
 $V_{IH}=3.0V, V_{IL}=0.0V$ (-55HI)
 Input rise and fall time 5ns
 Reference level $V_{OH}=V_{OL}=1.5V$
 Output loads Fig.1, $C_L=100pF$ (-70HI)
 $C_L=30pF$ (-55HI)
 $C_L=5pF$ (for t_{en}, t_{dis})
 Transition is measured ± 500mV from steady state voltage. (for t_{en}, t_{dis})

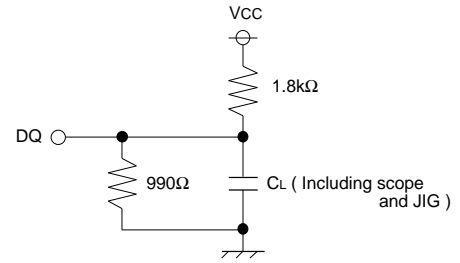

Fig.1 Output load

(2) READ CYCLE

Symbol	Parameter	Limits				Unit
		-55HI		-70HI		
		Min	Max	Min	Max	
t _{CR}	Read cycle time	55		70		ns
t _{a(A)}	Address access time		55		70	ns
t _{a(S1)}	Chip select 1 access time		55		70	ns
t _{a(S2)}	Chip select 2 access time		55		70	ns
t _{a(OE)}	Output enable access time		30		35	ns
t _{dis(S1)}	Output disable time after $\overline{S_1}$ high		20		25	ns
t _{dis(S2)}	Output disable time after S_2 low		20		25	ns
t _{dis(OE)}	Output disable time after \overline{OE} high		20		25	ns
t _{en(S1)}	Output enable time after $\overline{S_1}$ low	5		10		ns
t _{en(S2)}	Output enable time after S_2 high	5		10		ns
t _{en(OE)}	Output enable time after \overline{OE} low	5		5		ns
t _{V(A)}	Data valid time after address	5		10		ns

(3) WRITE CYCLE

Symbol	Parameter	Limits				Unit
		-55HI		-70HI		
		Min	Max	Min	Max	
t _{cw}	Write cycle time	55		70		ns
t _{w(W)}	Write pulse width	45		50		ns
t _{su(A)}	Address setup time	0		0		ns
t _{su(A-WH)}	Address setup time with respect to \overline{W}	50		55		ns
t _{su(S1)}	Chip select 1 setup time	50		55		ns
t _{su(S2)}	Chip select 2 setup time	50		55		ns
t _{su(D)}	Data setup time	25		30		ns
t _{h(D)}	Data hold time	0		0		ns
t _{rec(W)}	Write recovery time	0		0		ns
t _{dis(W)}	Output disable time from \overline{W} low		20		25	ns
t _{dis(OE)}	Output disable time from \overline{OE} high		20		25	ns
t _{en(W)}	Output enable time from \overline{W} high	5		5		ns
t _{en(OE)}	Output enable time from \overline{OE} low	5		5		ns

(4) TIMING DIAGRAMS

Read cycle

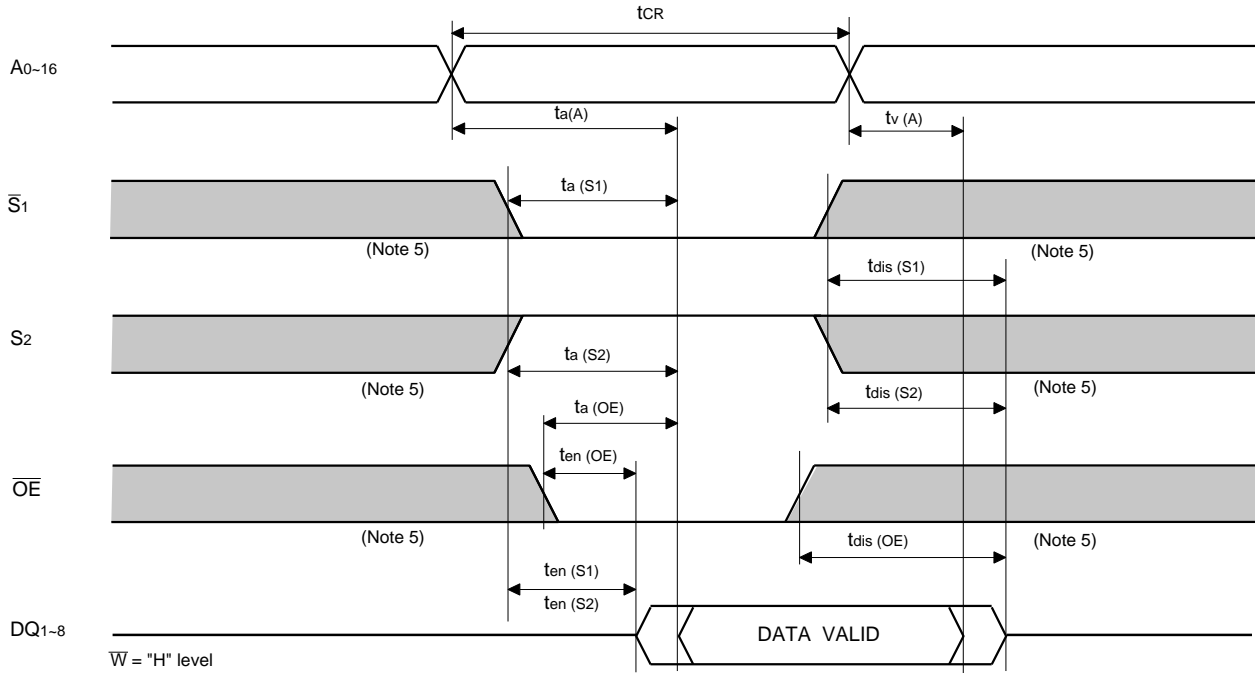

Write cycle (W control mode)

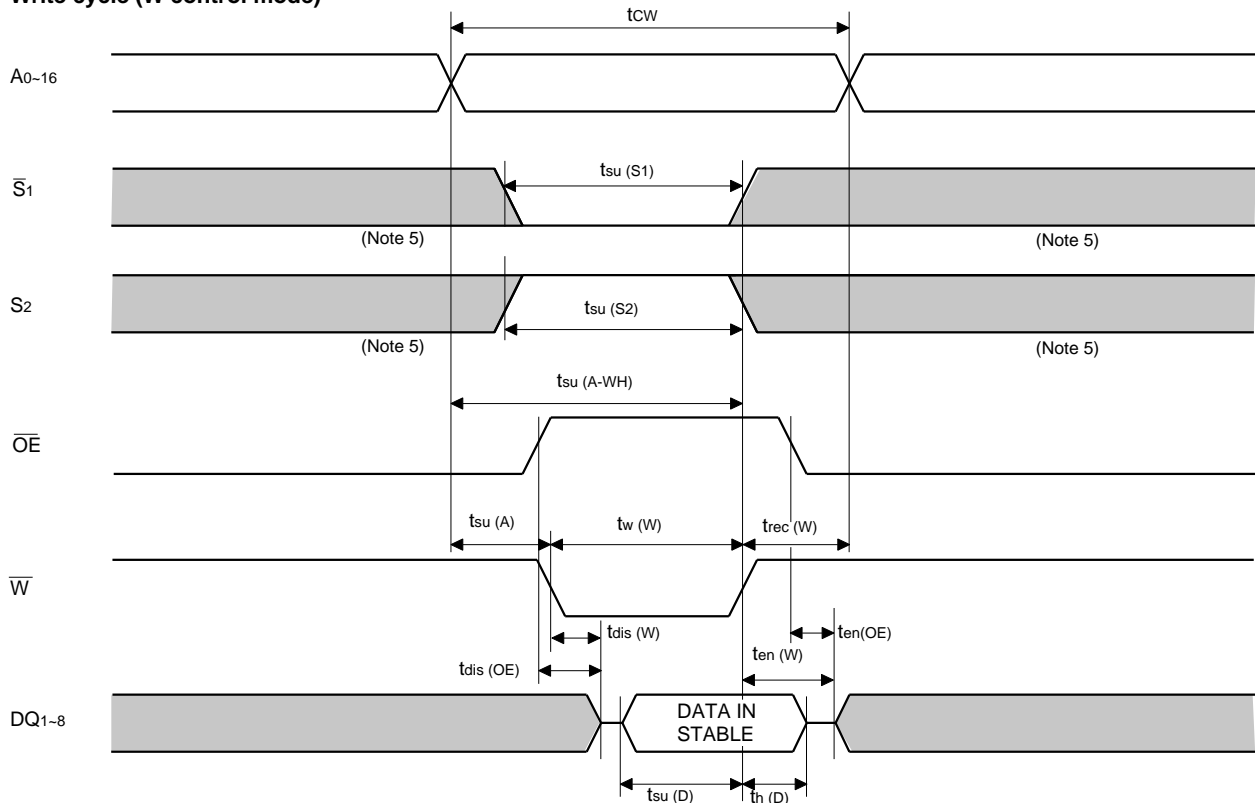

Write cycle (\bar{S}_1 control mode)

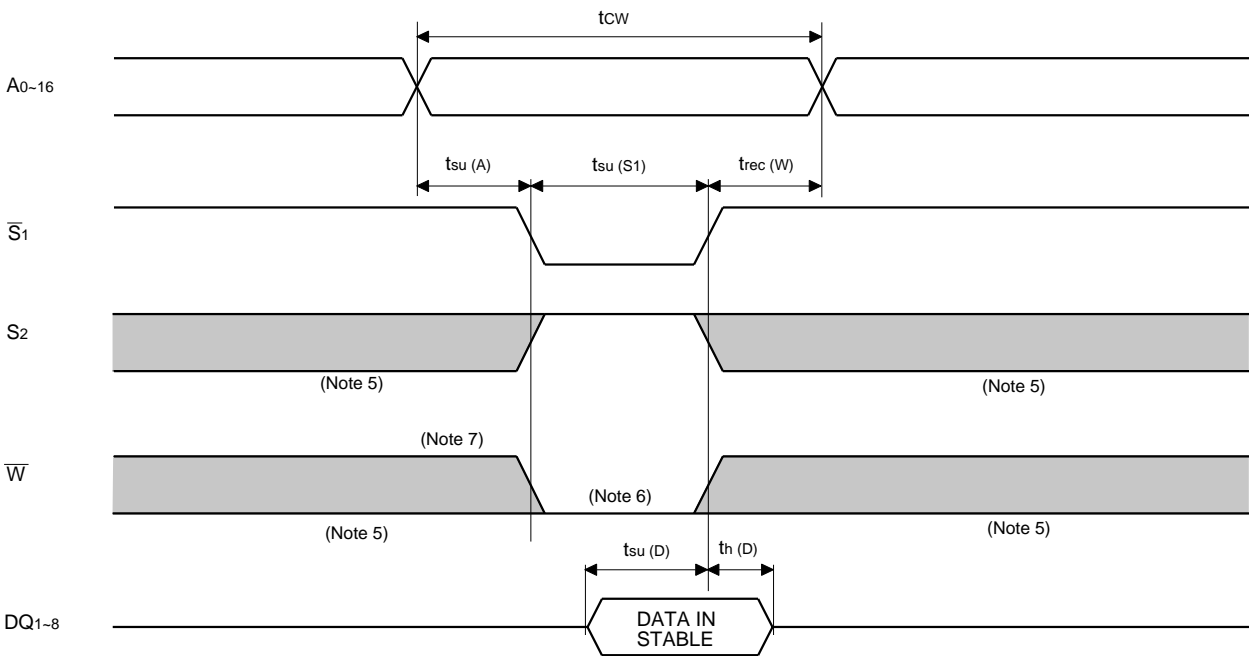

Write cycle (S_2 control mode)

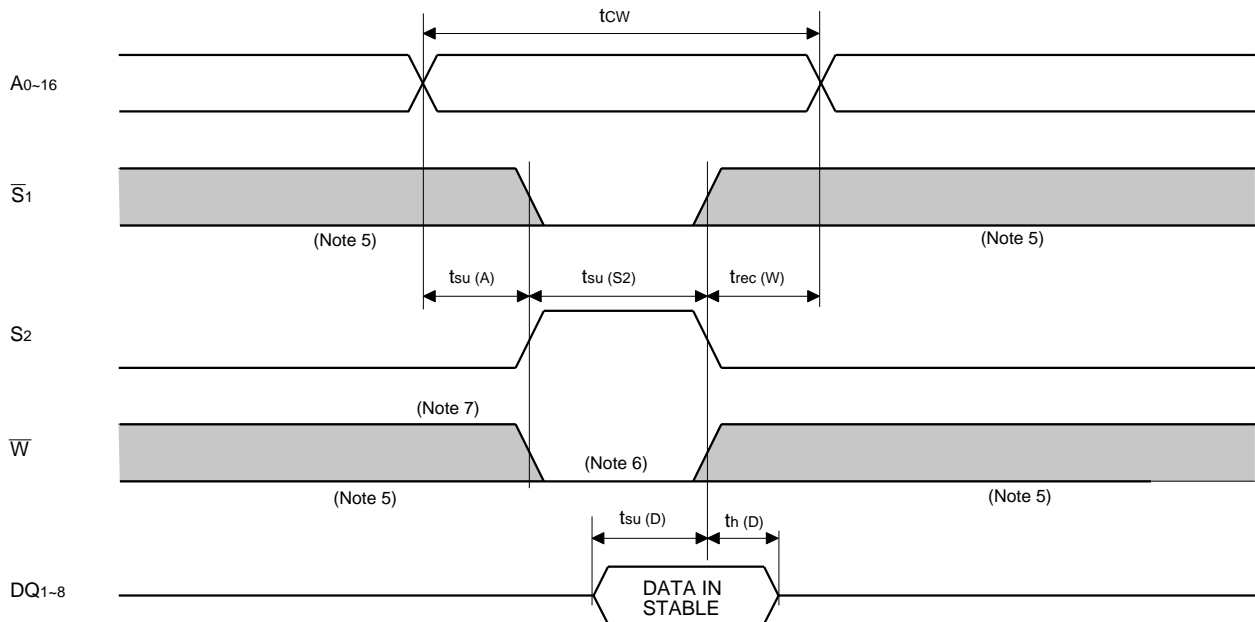

- Note 5: Hatching indicates the state is "don't care".
 6: Writing is executed while S_2 high overlaps \bar{S}_1 and \bar{W} low.
 7: When the falling edge of \bar{W} is simultaneously or prior to the falling edge of \bar{S}_1 or rising edge of S_2 , the outputs are maintained in the high impedance state.
 8: Don't apply inverted phase signal externally when DQ pin is output mode.

POWER DOWN CHARACTERISTICS**(1) ELECTRICAL CHARACTERISTICS** ($T_a = -40 \sim 85^\circ\text{C}$, unless otherwise noted)

Symbol	Parameter	Test conditions	Limits			Unit	
			Min	Typ	Max		
V_{CC} (PD)	Power down supply voltage		2.0			V	
V_I (S1)	Chip select input \bar{S}_1	$2.2\text{V} \leq V_{CC}(\text{PD})$	2.2			V	
		$2\text{V} \leq V_{CC}(\text{PD}) \leq 2.2\text{V}$		$V_{CC}(\text{PD})$			
V_I (S2)	Chip select input S_2	$4.5\text{V} \leq V_{CC}(\text{PD})$			0.8	V	
		$V_{CC}(\text{PD}) < 4.5\text{V}$			0.2		
I_{CC} (PD)	Power down supply current	$V_{CC} = 3\text{V}$ 1) $S_2 \leq 0.2\text{V}$, other inputs = $0 \sim 3\text{V}$ 2) $\bar{S}_1 \geq V_{CC} - 0.2\text{V}$, $S_2 \geq V_{CC} - 0.2\text{V}$ other inputs = $0 \sim 3\text{V}$	-HI	-25°C		1	μA
				-40°C		3	
				-70°C		10	
				-85°C		20	

(2) TIMING REQUIREMENTS ($T_a = -40 \sim 85^\circ\text{C}$, unless otherwise noted)

Symbol	Parameter	Test conditions	Limits			Unit
			Min	Typ	Max	
t_{su} (PD)	Power down set up time		0			ns
t_{rec} (PD)	Power down recovery time		5			ms

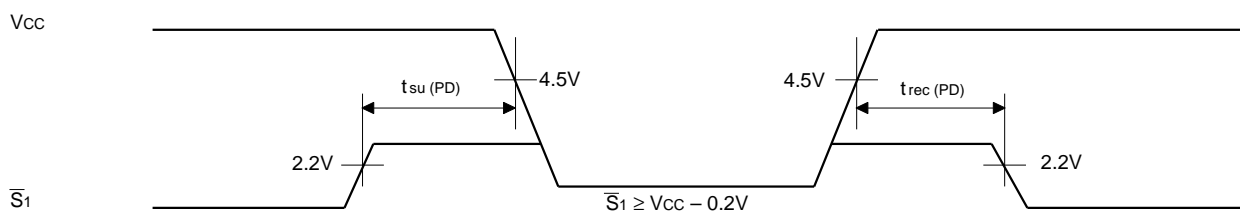
(3) POWER DOWN CHARACTERISTICS **\bar{S}_1 control mode**

Note 9: On the power down mode by controlling \bar{S}_1 , the input level of S_2 must be $S_2 \geq V_{CC} - 0.2\text{V}$ or $S_2 \leq 0.2\text{V}$. The other pins (Address, I/O, \bar{WE} , \bar{OE}) can be in high impedance state.

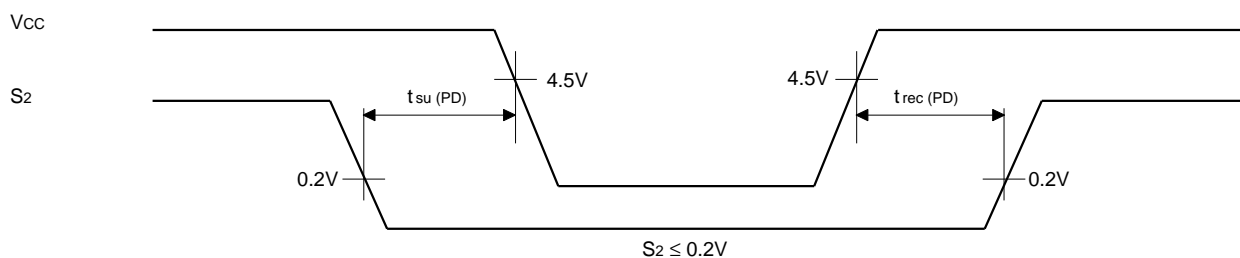
 S_2 control mode

Keep safety first in your circuit designs!

Mitsubishi Electric Corporation puts the maximum effort into making semiconductor products better and more reliable, but there is always the possibility that trouble may occur with them. Trouble with semiconductors may lead to personal injury, fire or property damage. Remember to give due consideration to safety when making your circuit designs, with appropriate measures such as (i) placement of substitutive, auxiliary circuits, (ii) use of non-flammable material or (iii) prevention against any malfunction or mishap.

Notes regarding these materials

These materials are intended as a reference to assist our customers in the selection of the Mitsubishi semiconductor product best suited to the customer's application; they do not convey any license under any intellectual property rights, or any other rights, belonging to Mitsubishi Electric Corporation or a third party.

Mitsubishi Electric Corporation assumes no responsibility for any damage, or infringement of any third-party's rights, originating in the use of any product data, diagrams, charts, programs, algorithms, or circuit application examples contained in these materials.

All information contained in these materials, including product data, diagrams, charts, programs and algorithms represents information on products at the time of publication of these materials, and are subject to change by Mitsubishi Electric Corporation without notice due to product improvements or other reasons. It is therefore recommended that customers contact Mitsubishi Electric Corporation or an authorized Mitsubishi Semiconductor product distributor for the latest product information before purchasing a product listed herein.

The information described here may contain technical inaccuracies or typographical errors. Mitsubishi Electric Corporation assumes no responsibility for any damage, liability, or other loss arising from these inaccuracies or errors.

Please also pay attention to information published by Mitsubishi Electric Corporation by various means, including the Mitsubishi Semiconductor home page (<http://www.mitsubishichips.com>).

When using any or all of the information contained in these materials, including product data, diagrams, charts, programs, and algorithms, please be sure to evaluate all information as a total system before making a final decision on the applicability of the information and products. Mitsubishi Electric Corporation assumes no responsibility for any damage, liability or other loss resulting from the information contained herein.

Mitsubishi Electric Corporation semiconductors are not designed or manufactured for use in a device or system that is used under circumstances in which human life is potentially at stake. Please contact Mitsubishi Electric Corporation or an authorized Mitsubishi Semiconductor product distributor when considering the use of a product contained herein for any specific purposes, such as apparatus or systems for transportation, vehicular, medical, aerospace, nuclear, or undersea repeater use.

The prior written approval of Mitsubishi Electric Corporation is necessary to reprint or reproduce in whole or in part these materials.

If these products or technologies are subject to the Japanese export control restrictions, they must be exported under a license from the Japanese government and cannot be imported into a country other than the approved destination. Any diversion or reexport contrary to the export control laws and regulations of Japan and/or the country of destination is prohibited.

Please contact Mitsubishi Electric Corporation or an authorized Mitsubishi Semiconductor product distributor for further details on these materials or the products contained therein.