

P/N PREFIX/SUFFIX TABLE		
LCM-X	DX	DESCRIPTION
STANDARD	S	SR STN, REFLECTIVE
	SF	SF STN, TRANSFLECTIVE(W/ BACKLIGHT)
HIGH TEMP.	H	TR TN, REFLECTIVE
	TF	TF TN, TRANSFLECTIVE(W/ BACKLIGHT)

CAUTION: STATIC SENSITIVE DEVICE
FOLLOW PROPER E.S.D. HANDLING PROCEDURES
WHEN WORKING WITH THIS PART.

CHARACTER DETAIL

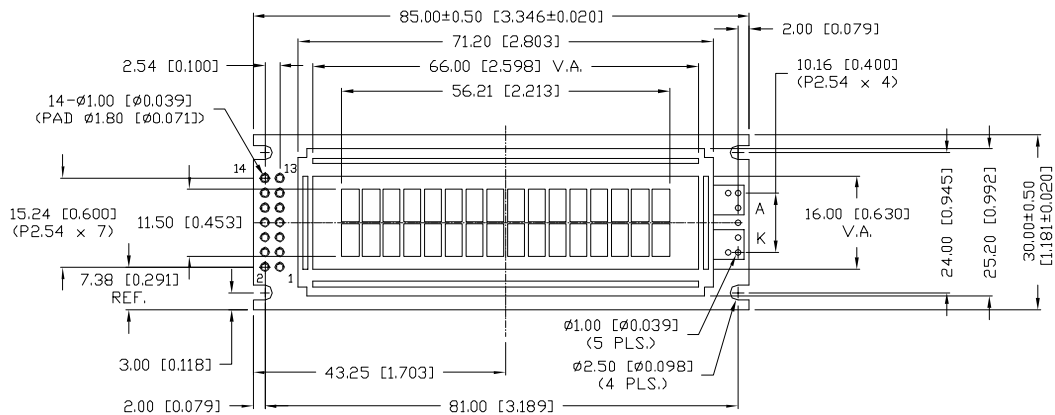
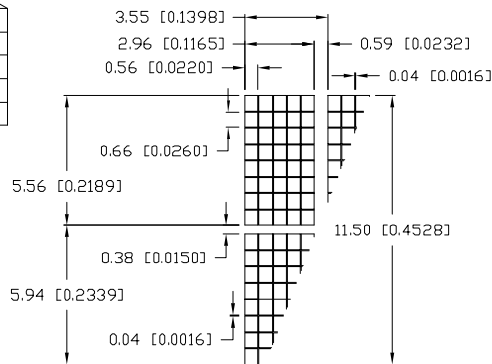

TYPE	DIM.	A	B
WITH BACKLIGHT		12.7	8.8
NO BACKLIGHT		8.9	4.8

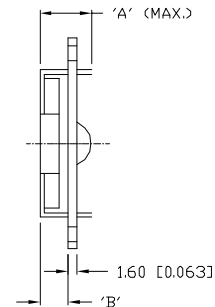

*UNLESS OTHERWISE SPECIFIED TOLERANCE IS ±0.25mm (±0.010")

REV. A	PART NUMBER LCM-X01602DXX/C
5.56mm CHARACTER HEIGHT, 5 x 8 DOT MATRIX, 16 x 2 LCD MODULE, 1/16 DUTY, 1/5 BIAS.	

CONFIDENTIAL INFORMATION
THE INFORMATION CONTAINED IN THIS DOCUMENT IS THE PROPERTY OF LUMEX INC. EXCEPT AS SPECIFICALLY AUTHORIZED IN WRITING BY LUMEX INC., THE HOLDER OF THIS DOCUMENT SHALL KEEP ALL INFORMATION CONTAINED HEREIN CONFIDENTIAL AND SHALL PROTECT SAME IN WHOLE OR IN PART FROM DISCLOSURE AND DISSEMINATION TO ALL THIRD PARTIES.

RELIABILITY NOTE
OUR MANY YEARS OF EXPERIENCE DATA ACCUMULATION INDICATE THAT SOLDER HEAT IS A MAJOR CAUSE OF EARLY AND FUTURE FAILURE. PLEASE PAY ATTENTION TO YOUR SOLDERING PROCESS.

		290 E. HELLEN ROAD PALATINE, ILLINOIS 60067 PHONE: 1-847-359-2790 WEB: HTTP://WWW.LUMEX.COM	
		DRAWN BY: SA/BC	CHECKED BY:

UNCONTROLLED DOCUMENT

PART NUMBER		REV.
LCM-X01602DXX/C		A
REV.	E.C.N. NUMBER AND REVISION COMMENTS	DATE
	SEE PAGE #1./	

PIN CONFIGURATION			
PIN NO.	SYMBOL	LEVEL	FUNCTION
1	V _{DD}	-	POWER SUPPLY 5V GND (0V) FOR LCD DRIVE
2	V _{SS}	-	
3	V _a	-	
4	RS	H/L	REGISTER SELECT SIGNAL H: DATA INPUT L: INSTRUCTION INPUT
5	R/W	H/L	H: DATA READ (MODULE-->MPU) L: DATA WRITE (MODULE<--MPU)
6	E	H,H->L	ENABLE
7~14	DB0~DB7	H/L	DATA BUS-SOFTWARE SELECTABLE 4 OR 8 BIT MODE.

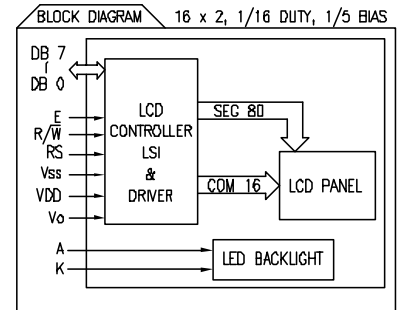
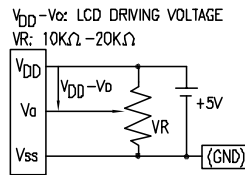

ELECTRICAL CHARACTERISTICS		V _{DD} =4.7V to 5.3V, T _A =25°C					
ITEM	SYMBOL	CONDITION	STANDARD VALUE		UNIT		
			MIN.	TYP.	MAX.		
SUPPLY VOLTAGE FOR LOGIC	V _{DD} -V _{SS}	-	-	5.0	-	V	
SUPPLY CURRENT FOR LOGIC	I _{DD}	V _{DD} =5V	-	2.0	3.0	mA	
INPUT VOLTAGE	HIGH	V _{IH}	-	2.2	-	V _{DD} V	
	LOW	V _{IL}	-	0	-	0.6 V	
OUTPUT VOLTAGE	HIGH	V _{OH}	-	2.4	-	V	
	LOW	V _{OL}	-	-	-	0.4 V	
*LED BACKLIGHT	VOLTAGE	V _f	I _f =160mA	-	4.2	4.6	V
	CURRENT	I _f	-	-	160	-	mA
	POWER CONSUMPTION	PD	-	-	656	-	mW
	LUMINOUS	L	I _f =160mA	70	-	-	cd/m ²
	COLOR	-	-	-	-	-	nm

*ONLY APPLIES TO MODULES WITH BACKLIGHT

ABSOLUTE MAXIMUM RATINGS					
ITEM	SYMBOL	TEST CONDITION	STANDARD VALUE		UNIT
			MIN	MAX	
SUPPLY VOLTAGE FOR LOGIC	V _{DD} -V _{SS}	T _a =25°C	4.7	5.3	V
SUPPLY VOLTAGE FOR LCD DRIVE	V _{DD} -V _a	-	4.2@50°C	4.8@0°C	V
INPUT VOLTAGE	V _I	T _a =25°C	V _{SS}	V _{DD}	V
OPERATING TEMPERATURE	T _{opr}	LCM-S	0	50	°C
		LCM-H	-20	70	°C
		LCM-S	-20	70	°C
STORAGE TEMPERATURE	T _{stg}	LCM-H	-30	85	°C

UNCONTROLLED DOCUMENT
*UNLESS OTHERWISE SPECIFIED TOLERANCE IS ±0.25mm (±0.010")

REV. A	PART NUMBER LCM-X01602DXX/C	<p>CONFIDENTIAL INFORMATION THE INFORMATION CONTAINED IN THIS DOCUMENT IS THE PROPERTY OF LUMEX INC. EXCEPT AS SPECIALLY AUTHORIZED IN WRITING BY LUMEX INC., THE HOLDER OF THIS DOCUMENT SHALL KEEP ALL INFORMATION CONTAINED HEREIN CONFIDENTIAL AND SHALL PROTECT SAME IN WHOLE OR IN PART FROM DISCLOSURE AND DISSEMINATION TO ALL THIRD PARTIES.</p> <p>RELIABILITY NOTE OUR MANY YEARS OF EXPERIENCE DATA ACCUMULATION INDICATE THAT SOLDER HEAT IS A MAJOR CAUSE OF EARLY AND FUTURE FAILURE. PLEASE PAY ATTENTION TO YOUR SOLDERING PROCESS.</p>	<p>LUMEX INCORPORATED</p> <p>290 E. HELLEN ROAD PALATINE, ILLINOIS 60067 PHONE: 1-847-359-2790 WEB: HTTP://WWW.LUMEX.COM</p>
5.56mm CHARACTER HEIGHT, 5 x 8 DOT MATRIX, 16 x 2 LCD MODULE, 1/16 DUTY, 1/5 BIAS.		<p>DRAWN BY: SA/BC</p> <p>CHECKED BY:</p> <p>APPROVED BY:</p>	<p>DATE: 7-31-98</p> <p>PAGE: 2 OF 2</p> <p>SCALE: N/A</p>